

Fluid dispensing system

Models MV7102, MV7105, MV7110, MV7120, MV7135, MV7412, MV7840

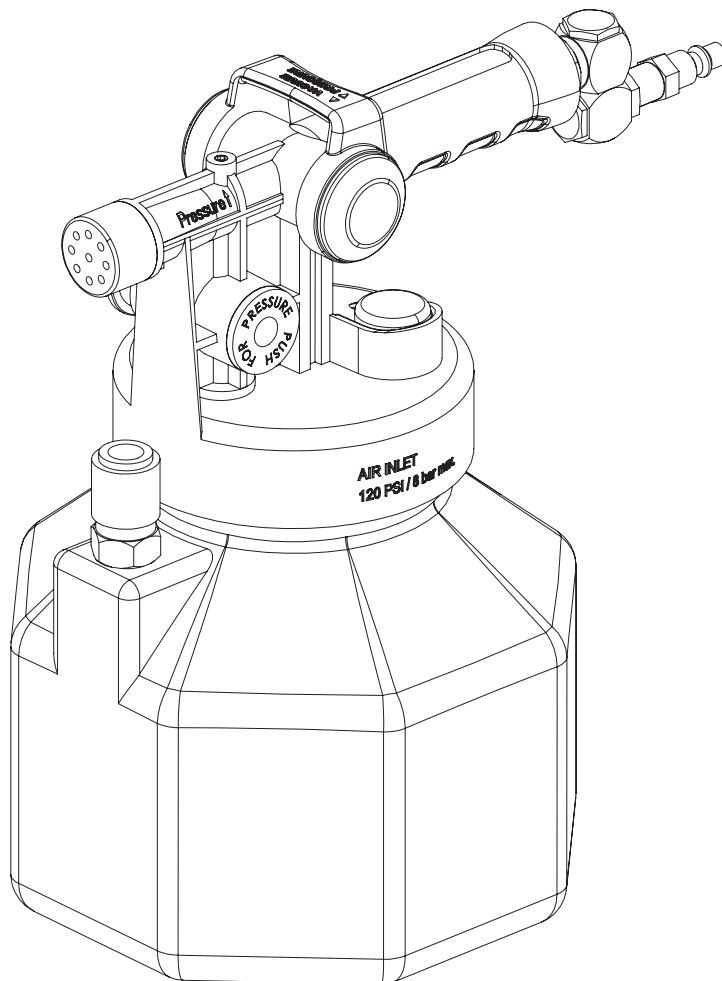

MV7102 model shown

Contents

Safety	2
Usage	3
Description	3
Applications	3
Specifications	3
Operation	4
To dispense fluid	4
To evacuate fluid	4
Pressure brake bleeding	6
Evacuating ATF	8
Refilling ATF	8
Service parts	10
Standard accessories	10

Safety

Read and carefully observe this operating instruction before use.

This equipment is designed to be used by trained vehicle service personnel. Consult and follow vehicle manufacturer's recommendations regarding service procedures and fluid compatibility. Do not use this equipment in a way that is not described in this documentation.

Equipment and vehicle components build up pressure. Fluid may be expelled when disconnecting a hose or other component.

Always wear eye protection and proper clothing when operating this equipment

Do not attempt to modify pressure relief valve. If pressure in reservoir exceeds 25 psi (1.7 bar), return it to an authorized service center for repair or replacement.

Some fluids, including brake fluid, are corrosive. Proper care should be taken to protect painted surfaces and skin from exposure.

Explanation of signal words for safety

NOTE

Emphasizes useful hints and recommendations as well as information to prevent property damage and ensure efficient trouble-free operation.

⚠ CAUTION

Indicates a dangerous situation that can lead to light personal injury if precautionary measures are ignored.

⚠ WARNING

Indicates a dangerous situation that could lead to death or serious injury if precautionary measures are ignored.

⚠ DANGER

Indicates a dangerous situation that will lead to death or serious injury if precautionary measures are ignored.

Usage

Description

This equipment is designed to dispense and evacuate fluid using compressed air to build pressure or vacuum in reservoir. Through a fluid pickup tube connected to a quick-change coupler, air pressure forces fluid to dispense out of reservoir or air vacuum pulls fluid into reservoir. Accessories can be added to control or direct fluid flow in different applications.

Operate equipment at input pressure of 90-120 psi (6-8 bar). Regularly check reservoir pressure gauge during operation to ensure pressure remains at or below recommended levels of 25 psi (1.7 bar).

Applications

This equipment is intended to empty or fill reservoirs with the following fluids: engine coolant, windshield washer fluid, motor oil, diesel fuel, automatic transmission fluid (ATF), brake fluid or power steering fluid.

Accessories can be used to pressure/vacuum bleed hydraulic brake or clutch systems, or refill or top-off sealed automatic transmissions.

⚠ WARNING

Do not use this equipment with gasoline or other flammable liquids, or with fluids at temperatures above 175° F (80° C).

Failure to comply could result in death or serious injury.

⚠ DANGER

Do not use this equipment with any fluid at temperatures above its flash point.

Do not use equipment with any flammable fluid having a flash point below 100 °F (37.7 °C).

Enough vapor to ignite in air may exist if equipment is used with fluid at a temperature above its flash point, resulting in fire or explosion.

Failure to comply could result in death or serious injury.

⚠ WARNING

Always wear safety goggles when operating this equipment. Fluid can splash into eyes.



Failure to comply could result in death or serious injury.

⚠ WARNING

Do not exceed 25 psi (1.7 bar) in reservoir. Relief valve is designed to prevent this, but if pressure exceeds 25 psi (1.7 bar), immediately discontinue use and send unit to an authorized service center for repair or replacement.

Failure to comply could result in death or serious injury.

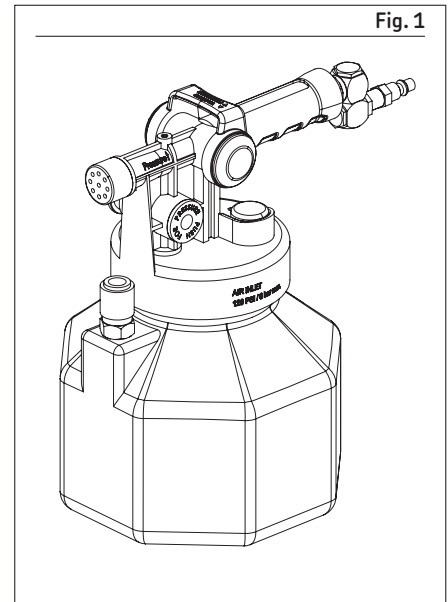

Table 1

Specifications

Inlet pressure	90-120 psi (6-8 bar)
Operating pressure	20 to 25 psi (1.4 to 1.7 bar)
Maximum reservoir pressure	25 psi (1.7 bar) (170 kPa)

Table 2

Model	Reservoir	Included accessories
MV7102	2.5 quart (2.5 l)	—
MV7105	1.2 gal (5 l)	—
MV7110	2.5 gal (10 l)	Large wand (800816) and small wand (800817)*
MV7120	5 gal (20 l)	Large wand (800816) and small wand (800817)
MV7135	2.5 quart (2.5 l)	Brake bleed adapters (822664 and 822694) and refill kit (MVA6832)
MV7412	2.5 gal (10 l)	ATF refill kit (MVA5800A)
MV7840	2.5 quart (2.5 l)	Pressure brake bleed adapter kit (MVA6850)

* Indicates change

Operation

- 1 Thread lid (10) tightly onto reservoir (12) (→ Fig. IPB 2, page 10 and Fig. IPB 3, page 10).
- 2 Connect fluid dispensing hose (14) or accessory to quick-connect coupler (4).

NOTE

Verify quick-connect coupler sleeve snaps to lock connection.

- 3 Set inlet air supply between 90-120 psi (6-8 bar).
- 4 Attach air supply to swivel coupler (7).

To dispense fluid

- 1 Set slide valve (5) to pressure setting (→ Fig. 2, page 5; Fig. IPB 2, page 10 and Fig. IPB 3, page 10).
- 2 Pull top lever (6) back to build pressure in reservoir (12) and dispense fluid.
- 3 To stop dispensing fluid, close shut-off valve on fluid dispensing hose (14) and push top lever (6) to center position.
- 4 Bleed off pressure by tilting pressure relief knob (8) or setting the slide valve (5) to the vacuum position.

To evacuate fluid

- 1 Set slide valve (5) to vacuum setting (→ Fig. 3, page 5; Fig. IPB 2, page 10 and Fig. IPB 3, page 10).
- 2 Push top lever (6) forward to vacuum and pull fluid into reservoir (12).
- 3 To stop, close shut-off valve on fluid dispensing hose (14) and pull top lever (6) to center position.
- 4 Release vacuum pressure by tilting pressure relief knob (8).

NOTE

Air supply is not necessary to evacuate fluids once vacuum is generated. Reservoir can remain under vacuum for a period of time even after air supply is removed if slide valve (5) is moved to pressure setting before top lever (6) is moved to center.

NOTE

Built-in pressure relief valve (8) is designed to open and maintain maximum pressure between 20 and 25 psi (1.4 and 1.7 bar).
Fluid will continue to flow as long as pressure/vacuum remains in reservoir.

NOTE

Shut-off valve installed in fluid dispensing hose (14) may be left open or closed. When left open, fluid will flow when top lever (6) is operated. If closed, pressure/vacuum will build in reservoir.

NOTE

Depending on fluid type and future intended use, remaining fluid may be stored in reservoir.

NOTE

Fluid may be left in reservoir.
If fluid is not stored in reservoir, clean using denatured alcohol or common household cleaner, and store empty. Do not use petroleum based solvents for cleaning unit.

Pressure brake bleeding

- 1 Park vehicle on level surface, set parking brake, and turn off engine.
- 2 Locate brake or clutch master cylinder and remove cap.

⚠ CAUTION

Do not allow fluids to contact skin or painted surfaces. Fluids are hazardous and corrosive to skin and painted surfaces.

Failure to comply could result in injury or damage to equipment.

- 3 Extract as much used hydraulic fluid from master cylinder reservoir as possible (→ *To evacuate fluid*, page 4).
- 4 Refill with new fluid.
- 5 Select appropriate master cylinder pressure bleed adapter and install securely onto master cylinder reservoir.

NOTE

Do not add fluid to dispenser reservoir until dispensing hose connections have been made and system has been checked for leaks.

- 6 Before adding fluid to reservoir (12), connect fluid dispensing hose (14) to quick-connect coupler (4) on reservoir. (→ Fig. 4, page 7).
- 7 Connect opposite end of the fluid dispensing hose (14) to the male quick-connect coupler on the master cylinder pressure bleed adapter.

NOTE

Verify all coupler sleeves snap to lock connection.

- 8 Ensure shut-off valve on fluid dispensing hose (14) is closed.
- 9 Connect air supply to swivel coupler (7).
- 10 Pull top lever (6) back to build pressure in reservoir.
- 11 Observe pressure gauge (9) and adjust inlet air supply to achieve 10 psi (0.7 bar) in reservoir. If inlet air supply cannot be adjusted, push top lever (6) to center position when reservoir pressure reaches 10 psi (0.7 bar).
- 12 Open shut-off valve on fluid dispensing hose (14) and watch pressure gauge (9) to ensure no leaks are present. If pressure steadily drops, relieve remaining pressure in system by tilting pressure relief knob (8) located on lid (10), remove and retighten lid from dispensing reservoir (12) and adapter on master cylinder reservoir, and recheck system for leaks.

- 13 Relieve pressure from reservoir (12) by tilting pressure relief knob (8).

⚠ WARNING

Do not remove lid from reservoir or adapter from master cylinder with system pressurized.

Failure to comply could result in death or serious injury.

- 14 Remove lid (10) from reservoir (12) and add up to 2 quarts (2 liters) of manufacturer's recommended new hydraulic fluid.

NOTE

Consult service manual to determine recommended bleed pressure and proper bleeding sequence for vehicle.

- 15 Install lid and tighten securely.
- 16 Pull top lever (6) back to build pressure in reservoir.
- 17 Observe pressure gauge (9) and adjust inlet air supply to achieve 10 psi (0.7 bar) in reservoir. If inlet air supply cannot be adjusted, push top lever (6) to center position when reservoir pressure reaches 10 psi (0.7 bar).
- 18 Connect bleed reservoir to bleed screw of first cylinder to be bled.
- 19 Open bleed screw.
- 20 Allow fluid to flow out until only clear new fluid with no visible air bubbles is streaming from screw. Re-tighten bleed screw to manufacturer's recommended torque.
- 21 Perform procedure on all remaining bleed screws.

NOTE

Do not allow dispensing unit and master cylinder reservoir to run dry. Use pressure relief valve (8) to relieve pressure and add new fluid if necessary.

- 22 Once all brakes are bled, relieve pressure in reservoir (12) and master cylinder by tilting pressure relief knob (8).
- 23 Close fluid dispensing hose (14) shut-off valve, and carefully remove adapter from master cylinder, being careful not spill brake fluid.
- 24 Extract excess fluid or top-off master cylinder as required, and replace cap.
- 25 Dispose of remaining hydraulic fluid.
- 26 Test brake or clutch system for leaks before driving vehicle.

NOTE

Do not store hydraulic fluid in reservoir (12). Clean dispensing unit with denatured alcohol and store properly.

Fig. 4

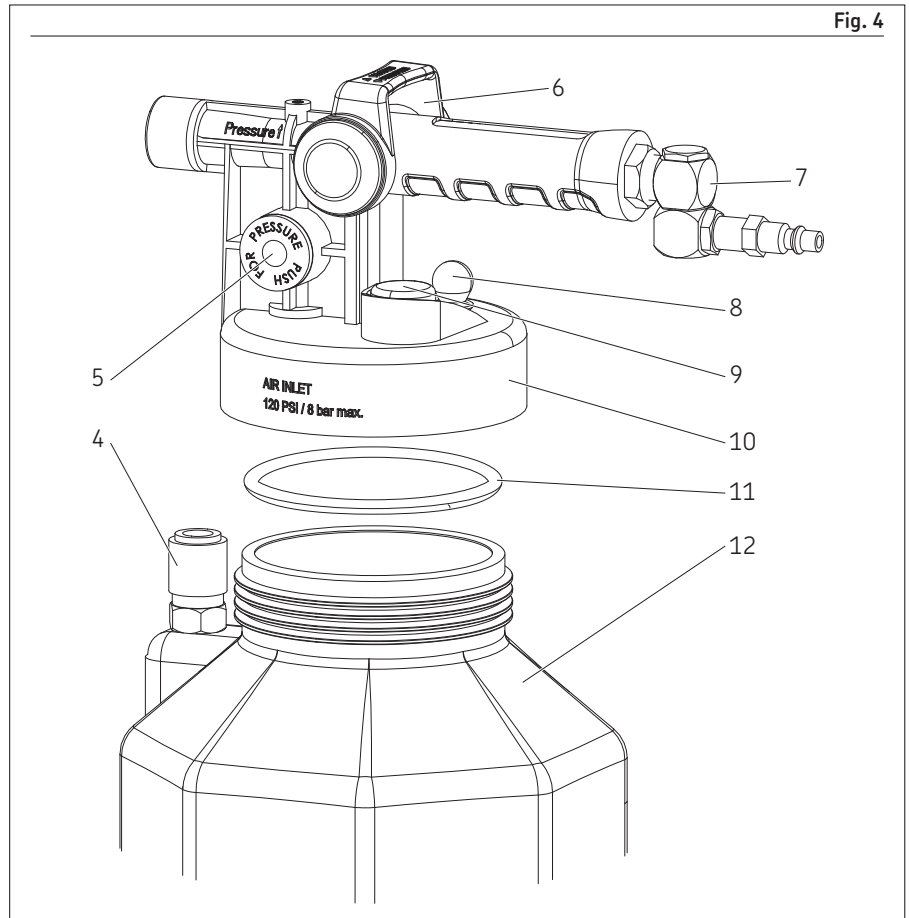

Evacuate sealed automatic transmissions

NOTE

Prior to starting evacuation/refilling, consult vehicle service manual for recommended procedures, fluids and capacities.

- 1 Connect fluid dispensing hose (14) to reservoir using quick-connect coupler (4) (→ Fig. 5, page 9 and Fig. IPB 3, page 10).
- 2 Evacuate ATF from transmission (→ *To evacuate fluid*, page 4).

NOTE

Verify quick-connect coupler sleeve snaps to lock connection.

Refill sealed automatic transmissions

- 1 Unscrew lid (10) from reservoir (12), and fill to desired level with new vehicle manufacturer's recommended transmission fluid (→ Fig. 5, page 9; Fig. IPB 2, page 10 and Fig. IPB 3, page 10).
- 2 Install lid (10) onto reservoir (12).

NOTE

Lifetime "sealed" transmissions require use of special manufacturer recommended fluids. Use of any other fluids may cause severe damage to transmission and void manufacturer's warranty.

- 3 Connect fluid dispensing hose (14) to reservoir using quick-connect coupler (4).

NOTE

Verify quick-connect coupler sleeve snaps to lock connection.

- 4 Select appropriate ATF refill adapter for application and connect to output of fluid dispensing hose (14).
- 5 Insert or connect ATF refill adapter to transmission.
- 6 Pull top lever (6) back to build pressure in reservoir until desired amount of fluid has been dispensed.

NOTE

Shut-off valve installed in fluid dispensing hose (14) may be left open or closed. When left open, fluid will begin to flow once pump is operated. If closed, pressure will build in reservoir as indicated on gauge.

- 7 Close shut-off valve on fluid dispensing hose (14).
- 8 Push top lever (6) to center position.
- 9 Bleed off pressure by tilting pressure relief knob (8).

NOTE

Check vehicle's service manual to determine proper method to check transmission fluid level.

Failure to follow manufacturer's recommended procedure could result in under- or over-filling transmission, causing severe transmission damage.

NOTE

Built-in pressure relief valve (8) is designed to open and maintain maximum pressure between 20 and 25 psi (1.4 and 1.7 bar).

Fluid will continue to flow as long as pressure remains in reservoir and shut-off valve is open.

⚠ WARNING

Do not exceed 25 psi (1.7 bar) in reservoir. Relief valve (8) is designed to prevent this, but if pressure exceeds 25 psi (1.7 bar), immediately discontinue use and send unit to an authorized service center for repair or replacement.

Failure to comply could result in death or serious injury.

NOTE

Depending on fluid type and future intended use, remaining fluid may be stored in reservoir.

NOTE

Fluid may be left in reservoir.

If fluid is not stored in reservoir, clean using denatured alcohol or common household cleaner, and store empty. Do not use petroleum based solvents for cleaning unit.

Fig. 5

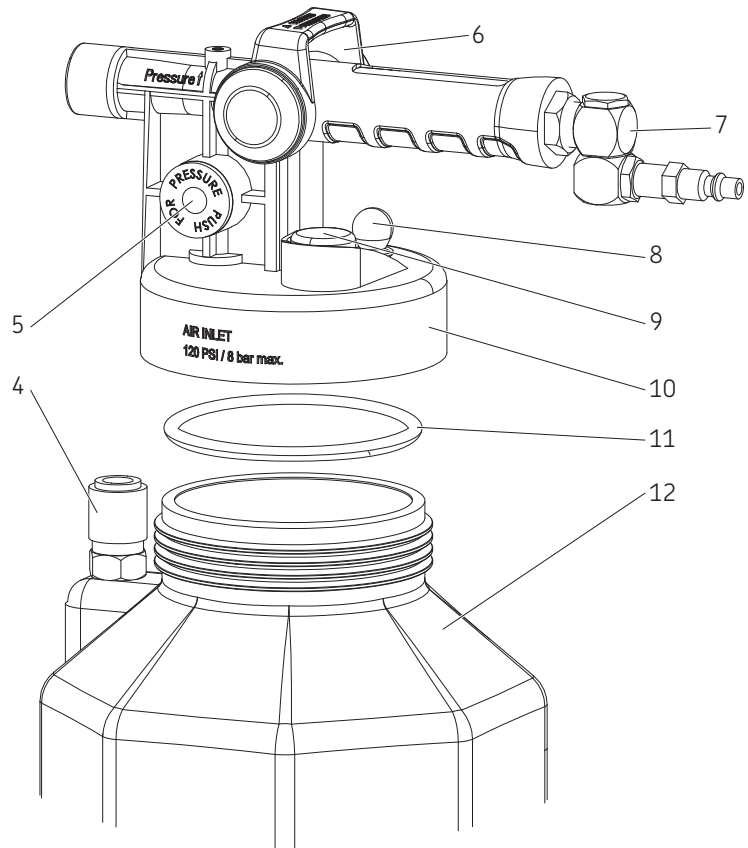

Fig. IPB 1

Service parts (internal)

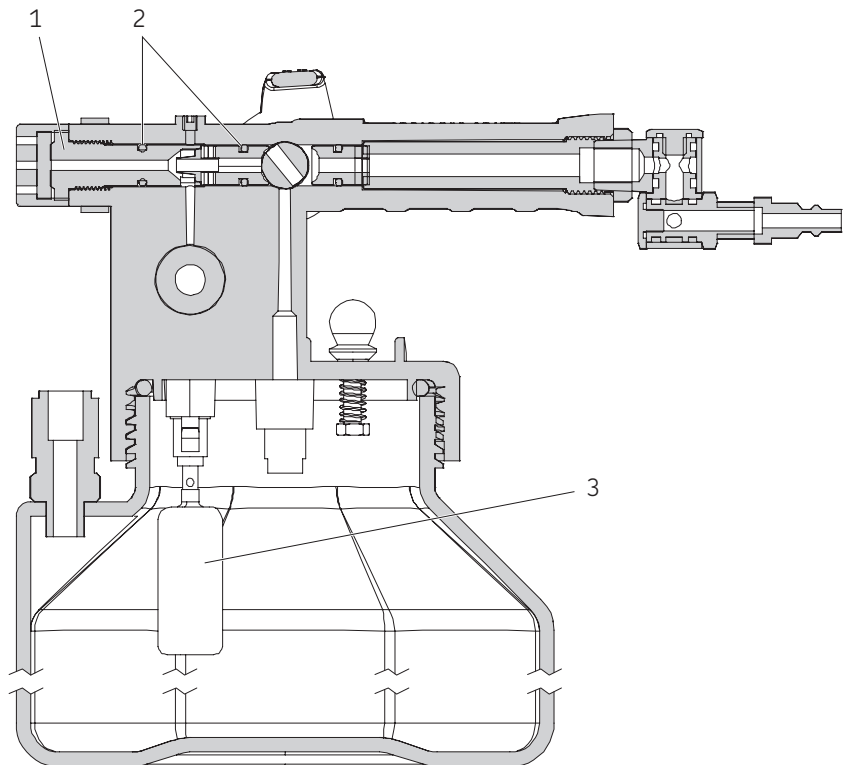
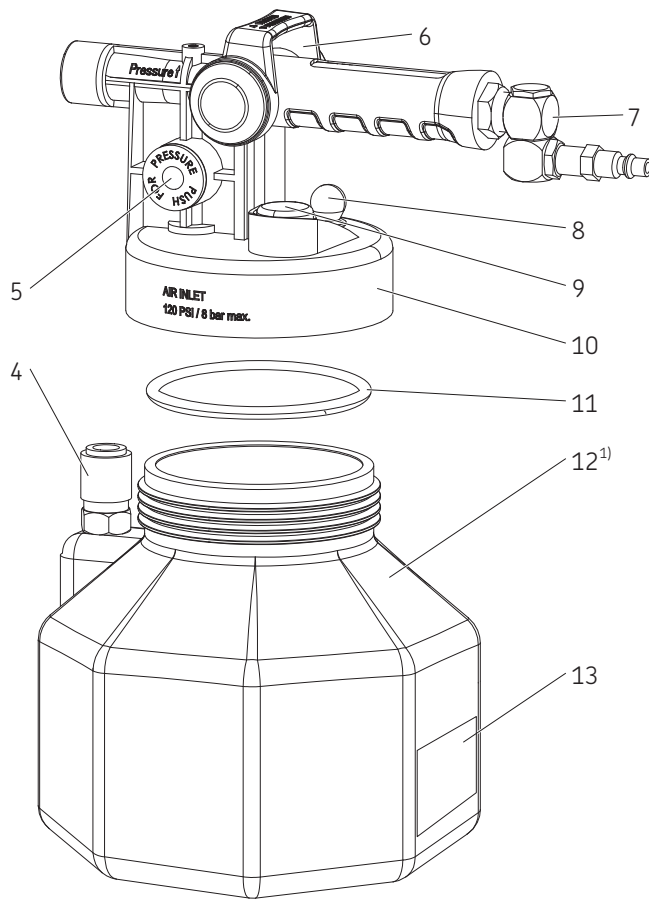

Fig. IPB 2

Service parts (pump and reservoir)



1) Reservoir sizes vary by model number.

Fig. IPB 3

Fluid hose (14)



Fig. IPB 4

Fluid dispensing wand (15)



Fig. IPB 5

Hanging hook (16)



Table 3

Service parts

Item	Description	MV7102	MV7105	MV7110	MV7120	MV7135	MV7412	MV7840
1	Muffler kit	822709	822709	822709	822709	822709	822709	822709
2	O-ring kit	822705	822705	822705	822705	822705	822705	822705
3	Float kit	822731	822731	822731	822731	822731	822731	822731
4	Quick-connect coupler	822703	822703	822703	822703	822703	822703	822703
5	Slide valve	N/A	N/A	N/A	N/A	N/A	N/A	N/A
6	Lever	N/A	N/A	N/A	N/A	N/A	N/A	N/A
7	Swivel coupler	822702	822702	822702	822702	822702	822702	822702
8	Pressure release valve	N/A	N/A	N/A	N/A	N/A	N/A	N/A
9	Reservoir pressure gauge	802443	802443	802443	802443	802443	802443	802443
10	Evacuating/Dispensing lid	802450	802450	802450	802450	802450	802450	802450
11	Gasket	801233	801233	801233	801233	801233	801233	801233
12	Reservoir	MVA574	MVA576	MVA572	MVA573	MVA574	MVA572	MVA574
13	Warning label	801188	801188	801188	801188	801188	801188	801188
14	Fluid hose	MVA575	MVA575	MVA575	MVA575	MVA575	MVA575	801212
15	Fluid dispensing wand	MVA570	MVA570	MVA570	MVA570	MVA570	MVA570	MVA570
16	Hanging hook	822753	822753	822753	N/A	822753	822753	822753

Not all parts or accessories are available separately.

Fig. 6

2.5 qt (2.5 l) system (MV7102)



Fig. 7

1.25 gal (5 l) system (MV7105)



Fig. 8

2.5 gal (10 l) system with large and small wands (MV7110)*



Fig. 9

5 gal (20 l) system with large and small wands (MV7120)



Fig. 10

2.5 qt (2.5 l) brake bleed and refill kit (MV7135)



Fig. 11

2.5 gal (10 l) with ATF adapter kit (MV7412)



Fig. 12

Pressure brake bleed kit (MV7840)



Fig. 13

ATF adapter kit (MVA5800A)



Fig. 14

ATF refill kit (MVA7216A)



Fig. 15

Brake bleeder kit (MVA6920)



Fig. 16

Brake bleeder and clamp-on auto refill kit (MVA6921)



Fig. 17

Master brake bleeder kit (MVA6922)



* Indicates change