

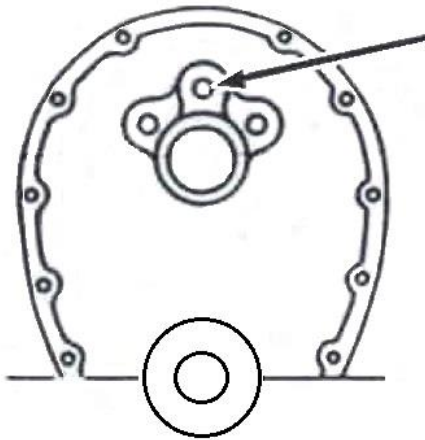

## **FREEZE PLUG INSTRUCTIONS 6481 & 6482**

1. Make sure all freeze plug bores are clean and all rust and corrosion has been removed to ensure proper sealing of new plugs.

**NOTE:** For some cylinder blocks, it may be necessary to tap the oil galley holes. Use either a 1/4" NPT or 3/8" NPT depending on the size of the plug that is being installed.



**CAUTION:** When installing the center oil galley plug on a small block Chevy, do not tap this plug in too deep or you will block the oil passage to the front cam bearing.