



I-SHEET PART NUMBER: INST-00240
 PART NUMBER: **NBC07CC-TX**
 PRODUCT: **NERF BOARD**
 APPLICATION: **07-18 CHEVY/GM 1500 CC**

HWKT-09617X		1
BHCS-09591X	M6X16MM BUTTON HEAD CAP SCREW	24
FW-09601	M6 FLAT WASHER	24
BHCS-09603	M6 flanged nut	24
CARB-09609	3/8"-16X1" Gr 5 Steel Carriage Bolt 1000B BLACK	12
FLNT-00664	3/8-16 GRADE 8 STEEL FLANGE NUT, ZINKLAD	12

HWKT-00424X		1
CLIP-00643	M8-1.25 X 20MM BARREL U-NUT CLIP	2
HHCS-00647	M8-1.25 X 25MM CLASS 8.8 HEX CAP SCREW	12
HXNT-00708	M8-1.25 CLASS 8 FINISHED HEX NUT	6
FDRW-00736	M8 FENDER WASHER	18

RAVEGR

RUNNING BOARD



PARTS INCLUDED	QTY
Driver Side Running Board	1
Passenger Side Running Board	1
Rocker panel brackets	6
Step Plate	4

Step 1: Identify Driver Side Nerf board.

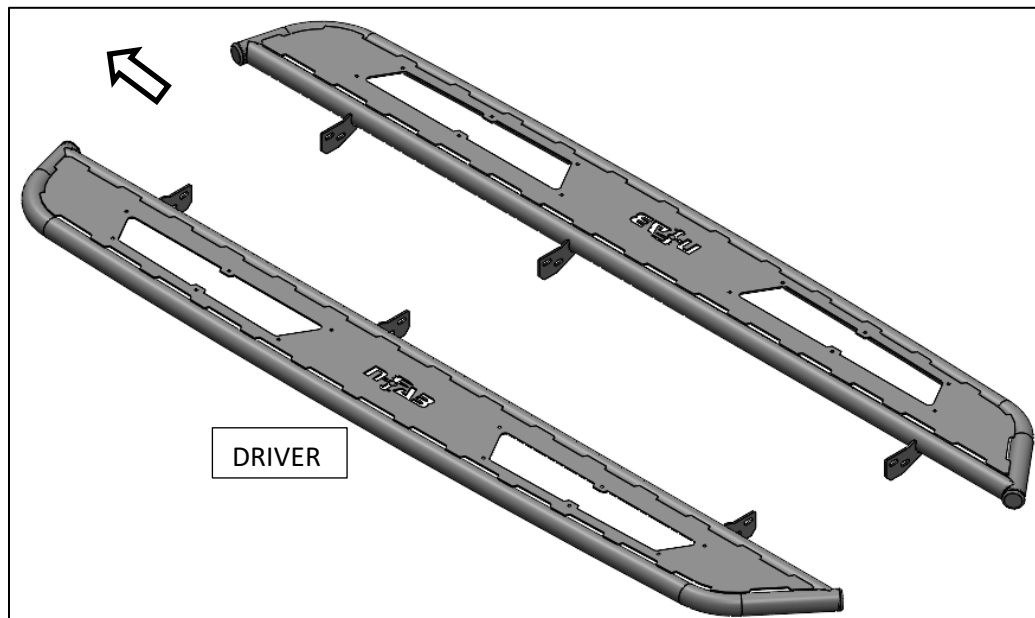

Step 2: Install the supplied step plate (x2) to each Running Board using the M6x20mm button head bolts, M6 nuts and M6 flat washer.

**** DO NOT OVER TIGHTEN ****

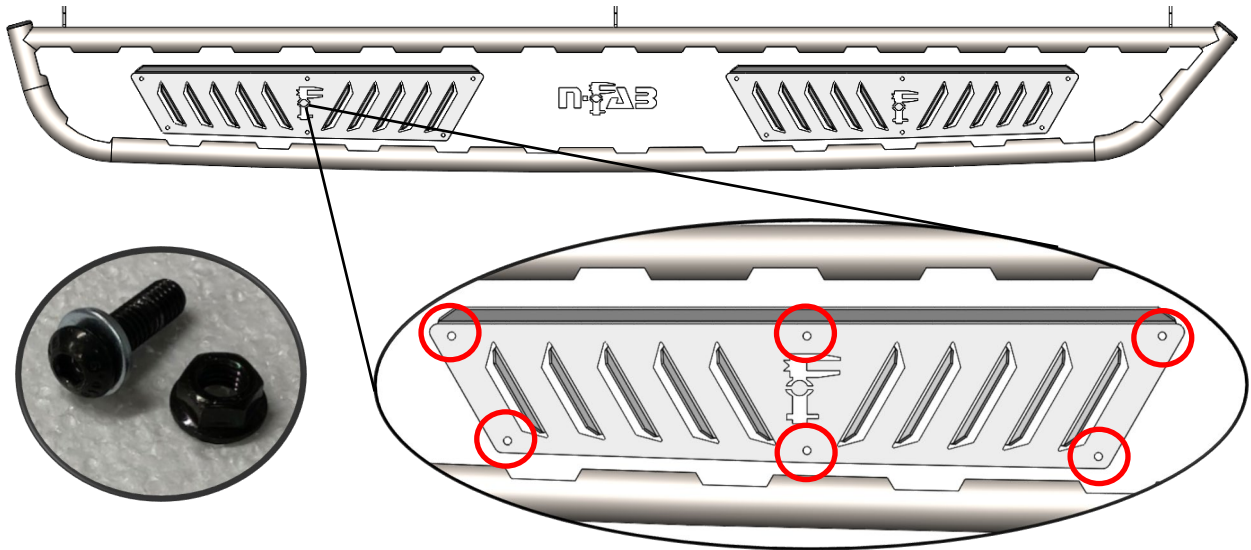

Step 3: Install the supplied rocker panel brackets (x6) to the attachments points located on the backside of the main tube (Driver/Passg) using the supplied 3/8" x 1" carriage bolts and 3/8" flanged nuts. Leave finger tight for now.

NOTE: *The brackets will attach to the forward side of the tabs with the threaded part of the carriage bolt facing to the rear of the vehicle.*

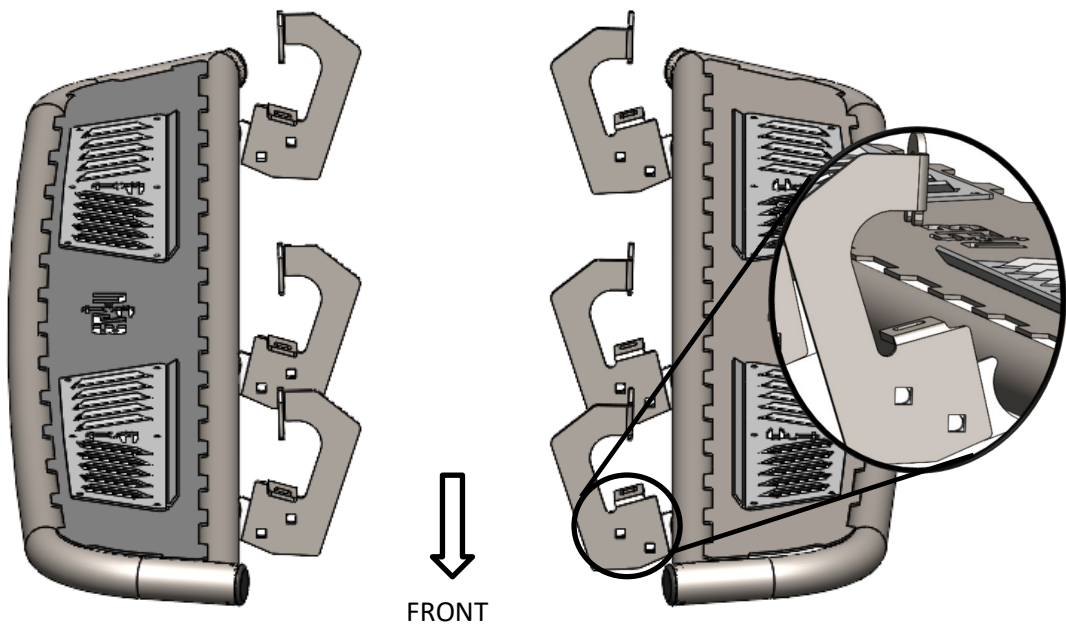



I-SHEET PART NUMBER: INST-00240
PART NUMBER: **NBC07CC-TX**
PRODUCT: **NERF BOARD**
APPLICATION: **07-18 CHEVY/GM 1500 CC**

Step 4: Look on the underside of the body and locate the factory supplied mounting positions.

NOTE: Some vehicles require the use of speed clips and nuts, which are supplied with the hardware kit.

Step 5: If your vehicle requires the use of the speed clips, install at this time. This requires the removal of a plastic body plug. Using a flat head screwdriver remove the plug and install one of the supplied speed clips.



Step 6: Align the Nerf Board with the mounting holes. Beginning with the middle bracket, use one M8-1.25 bolt and one fender washer for each mounting location and thread the bolts into the mounting holes and leave loose. Continue with the front and rear bracket. **NOTE: Some vehicles require the use of an additional nut and washer for the lower portion of the mounting bracket.**

Step 7: After final positioning, begin at the rear bracket and tighten the lower bolt to 15-20 ft. /lb. Continue to the front bracket and then to the center bracket. Next, tighten the upper mounts from front to back at 15-20 ft. /lb.



Step 8: There will be ½" of adjustment in the (x3) mounting bracket. Adjust to desired position and tighten to (20 ft./lbs).

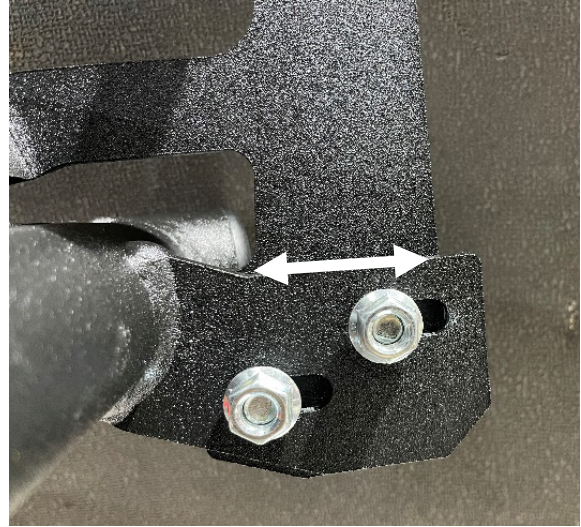

Step 9: Repeat steps 4-8 for the passenger side.