



I-SHEET PART NUMBER: INST-00238
 PART NUMBER: **NBF15CC-TX**
 PRODUCT: **NERF BOARD**
 APPLICATION: 15-21 F-150 CC / 17-21 F-250/350 CC

HWKT-09617X		QTY
BHCS-09591X	M6X16MM BUTTON HEAD CAP SCREW	24
FW-09601	M6 FLAT WASHER	24
BHCS-09603	M6 flanged nut	24
CARB-09609	3/8"-16X1" Gr 5 Steel Carriage Bolt 1000B BLACK ZINC	12
FLNT-00664	3/8-16 GRADE 8 STEEL FLANGE NUT, ZINKLAD 1000B	12

HWKT-00031X		QTY
M8-1.25 HEX FLANGED NUT		18
M8 FLAT WASHER		18

PARTS INCLUDED		QTY
Driver Side Running Board		1
Passenger Side Running Board		1
Rocker panel brackets		6
Step Plate		4

RAVEGR

RUNNING BOARD



Step 1: Identify Driver Side Nerf board.

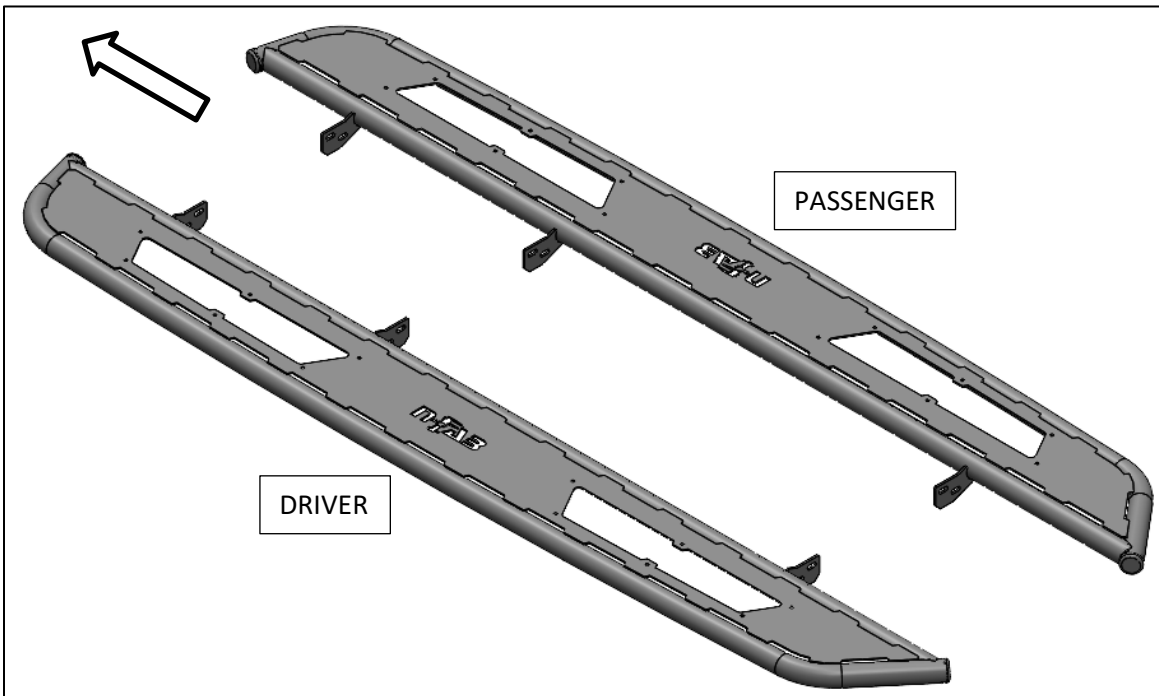

Step 2: Install the supplied step plate (x2) to each Running Board using the M6x20mm button head bolts, M6 nuts and M6 flat washer.

**** DO NOT OVER TIGHTEN ****

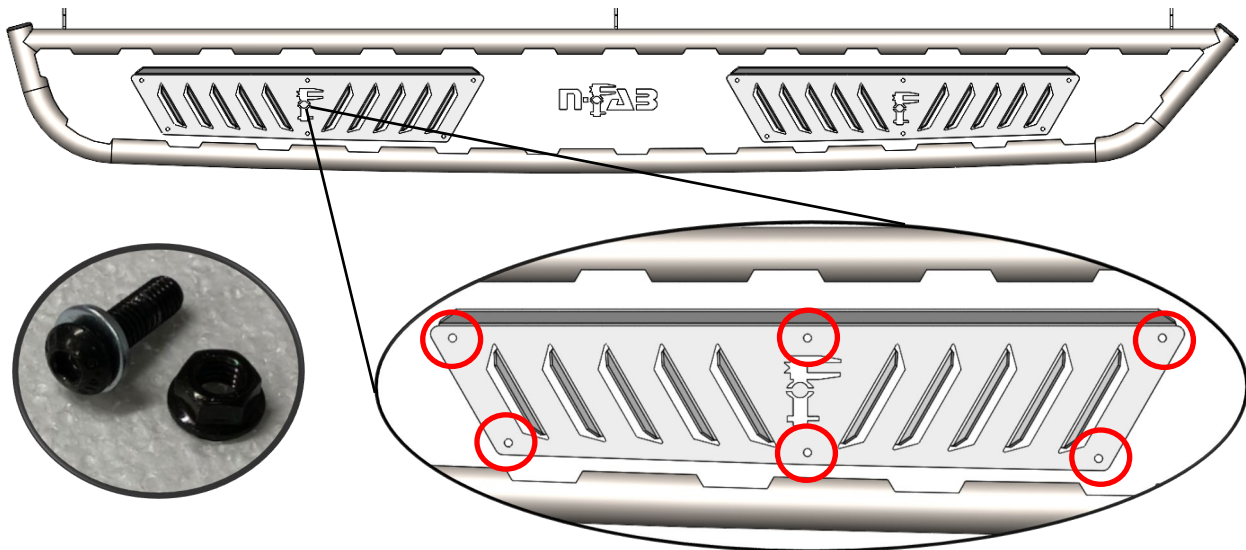

Step 3: Install (x3) mounting brackets to each attachment point with the supplied 3/8" x 1" carriage bolt and flanged 3/8" nut on the main tube. Hand tighten for now. Repeat with passenger side.

NOTE: Mounting brackets will be attached in the forward position with the threaded part of the carriage bolt facing towards the rear of the vehicle.

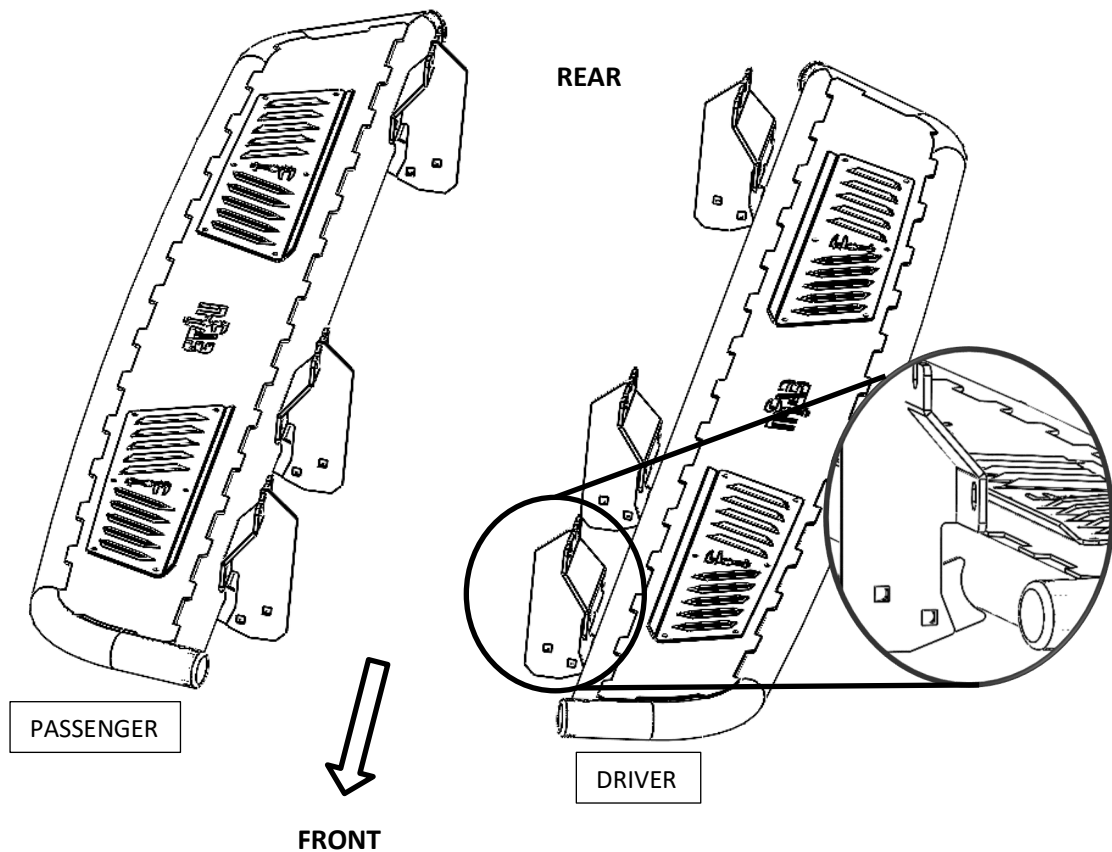



I-SHEET PART NUMBER: INST-00238
PART NUMBER: **NBF15CC-TX**
PRODUCT: **NERF BOARD**
APPLICATION: **15-21 F-150 CC / 17-21 F-250/350 CC**

Step 4: If equipped, remove all 8mm flange nuts from the threaded studs to remove the OE running boards.

***NOTE:** Threaded studs may need cleaning before install.

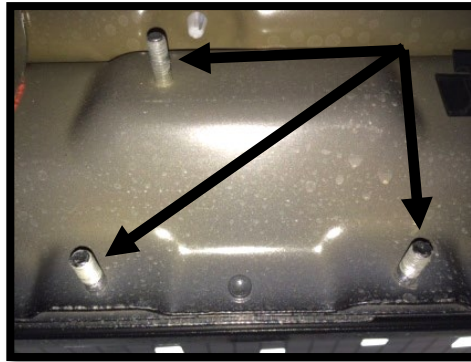

Step 5: Install Nerf Board assembly to the factory mounting location using the supplied M8 flanged hex nut and flat washer (x9). Leave loose for now.



Step 6: There will be $\frac{1}{2}$ " of adjustment in the (x3) mounting bracket. Adjust to desired position and tighten to (20 ft./lbs). Then tighten body mount brackets to (25-30 ft./lbs)

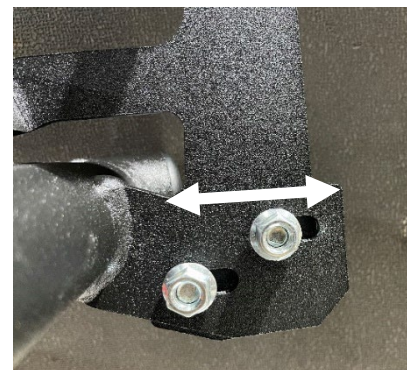

Step 7: Repeat steps 4-6 for the passenger side.