

OptiMATE solar Duo

OptiMate Solar DUO kits



INSTRUCTIONS FOR USE
IMPORTANT: Read completely
before charging

Standard models:

TM522-D1 : TM522-D charge controller + 10W polycrystalline panel
OUT: 12V / 12.8V 0.83A max.

TM522-D2 : TM522-D charge controller+ 20W polycrystalline panel
OUT: 12V / 12.8V 1.67A max.

TM522-D4 : TM522-D charge controller+ 40W polycrystalline panel
OUT: 12V / 12.8V 3.33A max.

Travel Kit models:

TM522-D1TK : TM522-D charge controller + 10W polycrystalline panel + 4x suction mounts + nylon storage case.
OUT: 12V / 12.8V 0.83A max.

TM522-D2TK : TM522-D charge controller + 20W polycrystalline panel + 4x suction mounts + nylon storage case.
OUT: 12V / 12.8V 1.67A max.

TM522-D4TK : TM522-D + 40W polycrystalline panel + adjustable stand + nylon storage case.
OUT: 12V / 12.8V 3.33A max.

OptiMate Solar DUO charge controller & monitor



Model : TM522-D DUO Solar charge controller and battery monitor for 12V lead-acid and 12.8V / 13.2V lithium ferrous phosphate batteries, for solar panels from 10–60W.

IN : 12V --- SOLAR PANEL 10–60W

OUT : DC output voltage : 12V ---
DC output current : 5A maximum.



Battery types: 12V Pb / Lead-acid: Flooded STD with liquid acid electrolyte / removable filler caps / EFB / Sealed AGM-MF / GEL / CYCLIC CELL

12.8V / 13.2V Li / Lithium Ferrous Phosphate: 4s
(4 cell in series)

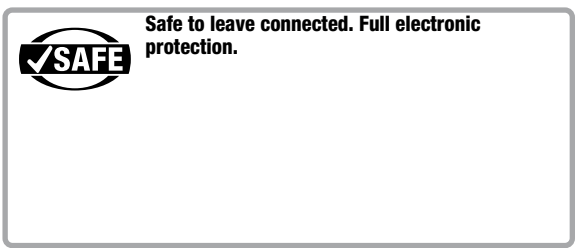
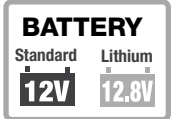
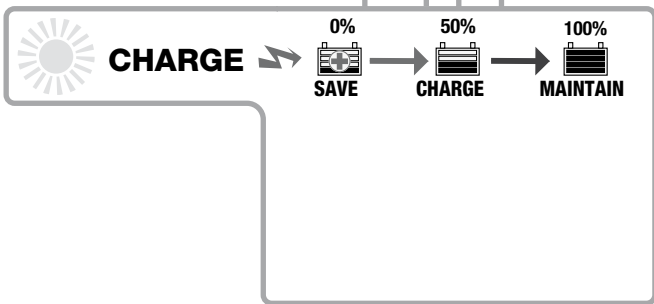
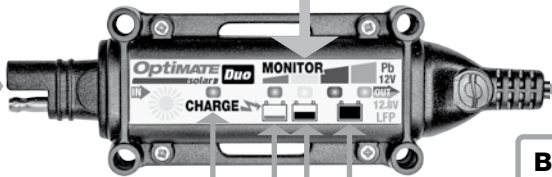
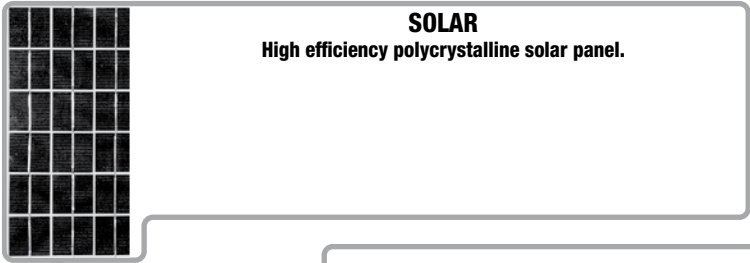

OptiMATE
solar

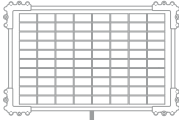

OptiMate Solar DUO kits

Polarity of exposed pin is Positive :

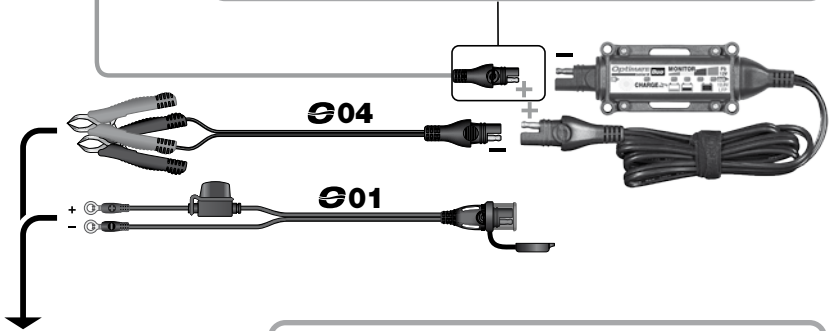

TM522-D Controller & Monitor

If used with another brand of solar panel, use 0-27 to correct polarity :

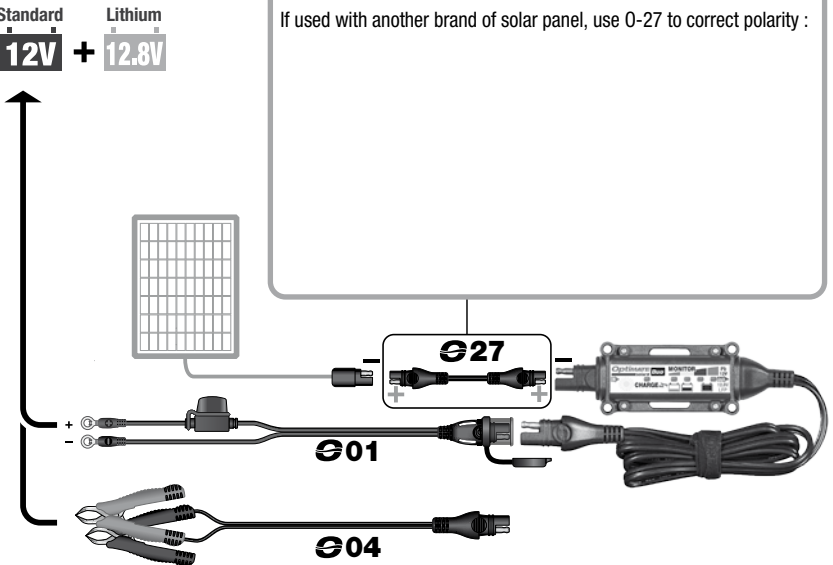

Permanent mount (x8)

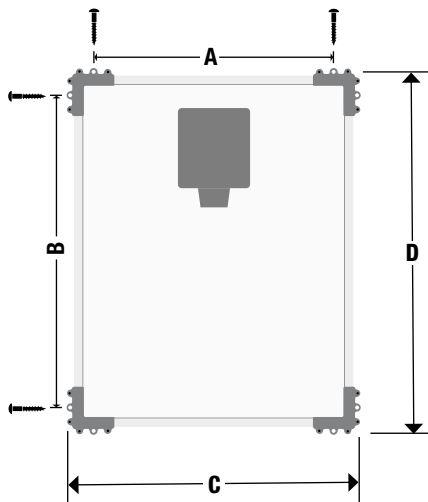
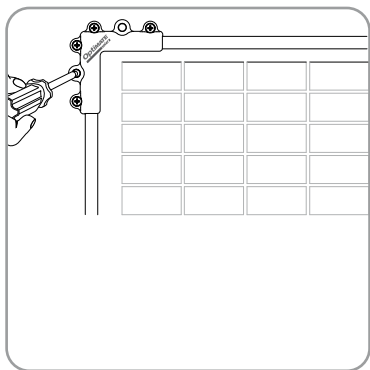

WATTS	A	B	C	D
10W	182mm (7.15")	223mm (8.78")	249mm (9.8")	376mm (14.8")
20W	295mm (11.59")	386mm (15.18")	362mm (14.3")	455mm (17.9")
40W	617mm (24.27")	361mm (14.20")	686mm (27")	420mm (16.6")

Suction mounts (x4) for window (part no.: TS-253)

TM522-D1-TK & TM522-D2-TK

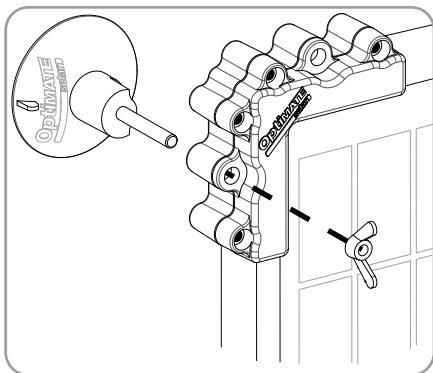
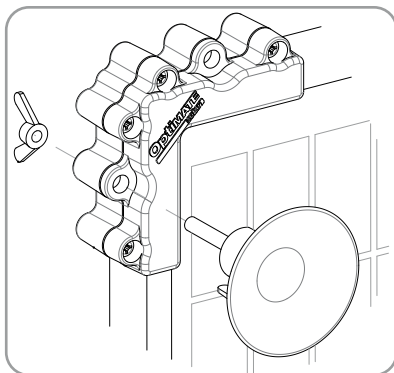

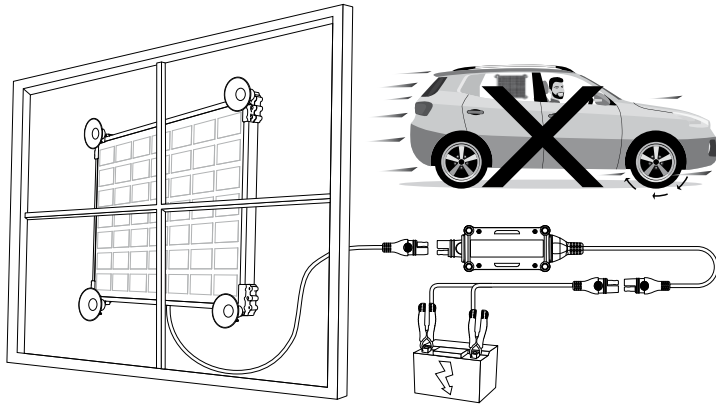

Included with

TM522-D4-TK

Adjustable rear stand - Adjusts panel to the most suitable angle for maximum solar power. Securing panel in position - Anchor points (x4) fit standard pegs / stakes (not included), or place a weight (e.g. sandbag) over the crossbar.

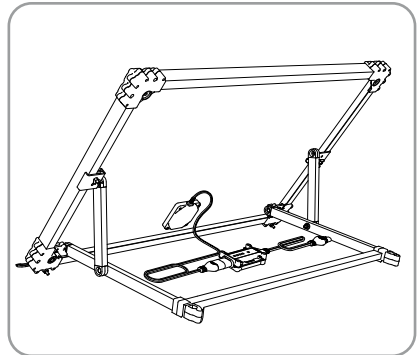

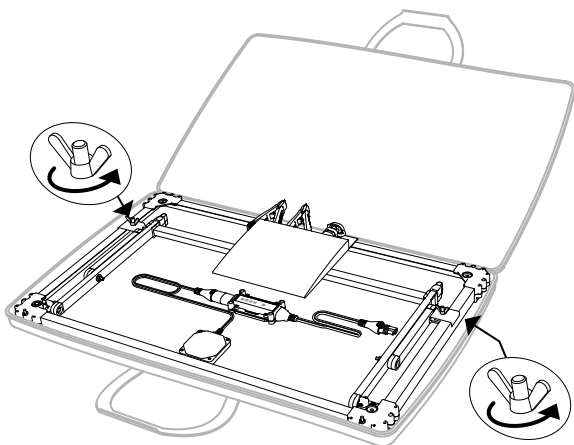
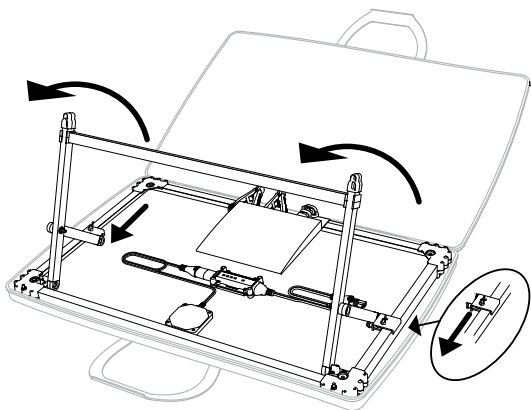
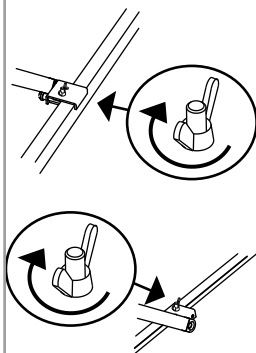
1**2****3**

4

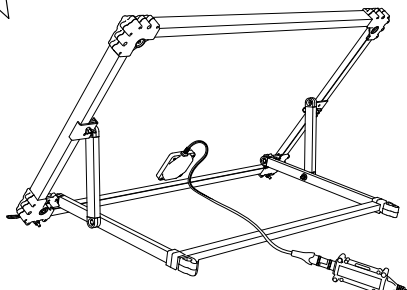
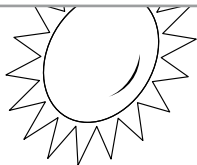

Protection against wind: Use bag of sand or pegs (not supplied)

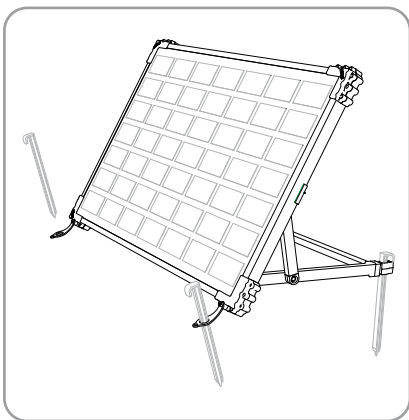
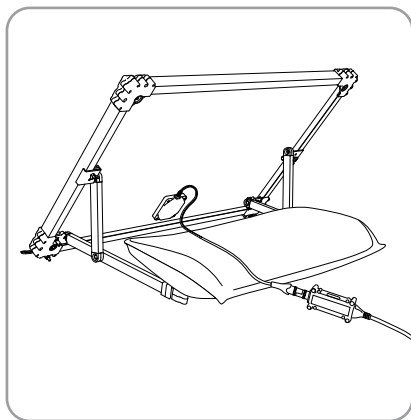

IMPORTANT: READ THE FOLLOWING INSTRUCTIONS BEFORE USING THE CHARGER.

NORTH AMERICAN SAFETY INSTRUCTIONS (see pages 11 & 12) ARE INCLUDED FOR CANADA & USA. IT IS OF THE UTMOST IMPORTANCE THAT EACH TIME, BEFORE USING THE CHARGER, YOU READ AND EXACTLY FOLLOW THESE INSTRUCTIONS. SAVE THESE INSTRUCTIONS.

This appliance can be used by children aged from 8 years and above and persons with reduced physical, sensory or mental capabilities or lack of experience and knowledge if they have been given supervision or instruction concerning use of the appliance in a safe way and understand the hazards involved. Children shall not play with the appliance. Cleaning and user maintenance shall not be made by children without supervision.

SAFETY WARNING AND NOTES: Batteries emit **EXPLOSIVE GASES - prevent flame or sparks near batteries.** Disconnect AC power supply before making or breaking DC/battery connections. Battery acid is highly corrosive. Wear protective clothing and eyewear and avoid contact. In case of accidental contact, wash immediately with soap and water. Check that the battery posts are not loose; if so, have the battery professionally assessed. If the battery posts are corroded, clean with a copper wire brush; if greasy or dirty clean with a rag damped in detergent. Use the charger only if the input and output leads and connectors are in good, undamaged condition. **If the input cable is damaged, it is essential to have it replaced without delay by the manufacturer, his authorised service agent or a qualified workshop, to avoid danger.** Protect your charger from acid and acid fumes and from damp and humid conditions both during use and in storage. Damage resulting from corrosion, oxidation or internal electrical short-circuiting is not covered by warranty. Distance the charger from the battery during charging to avoid contamination by or exposure to acid or acidic vapours. If using it in the horizontal orientation, place the charger on a hard, flat surface, but NOT on plastic, textile or leather. Use the fixing holes provided in the enclosure base to attach the charger to any convenient, sound vertical surface.

EXPOSURE TO LIQUIDS: This charger is designed to withstand exposure to liquids accidentally spilled or splashed onto the casing from above, or to light rainfall. Prolonged exposure to falling rain is inadvisable and longer service life will be obtained by minimizing such exposure. Failure of the charger due to oxidation resulting from the eventual penetration of liquid into the electronic components, connectors or plugs, is not covered by warranty.

BATTERY CONNECTIONS: 2 interchangeable connection sets are available, supplied with the charger is a set of battery clips for charging the battery off-vehicle, the other connection set comes with metal eyelet lugs for permanent connection to the battery posts, and re-sealable weatherproof cap on the connector that connects to the charger output cable. This connection set allows easy and sure connection of the charger to maintain the battery on-vehicle. The resealable weatherproof cap is designed to protect the connector from dirt and damp whenever the charger is not attached. Consult a professional service agent for assistance in attaching the metal eyelets to the battery posts. Secure the connector with weatherproof cap so that it cannot foul any moving part of the vehicle or the cable can be pinched or damaged by sharp edges. The in-line fuse in the eyelets connection set protects the battery against such accidental shorting across positive and negative conductors. Replace any burnt fuse only with a similar new fuse of 15A rating.

CONNECTING THE CHARGER TO THE BATTERY

1. Disconnect solar panel before making or breaking DC / battery connections.

2. If charging a battery in the vehicle with the battery clips, before making connections, first check that the battery clips can be safely and securely positioned clear from surrounding wiring, metal tubing or the chassis. Make connections in the following order:

First connect to the battery terminal not connected to the chassis (normally positive), then connect the other battery clip (normally negative) to the chassis well away from the battery and fuel line. Always disconnect in reverse sequence.

3. When charging a battery out of the vehicle with the battery clips, place it in a well ventilated area. Connect the charger to the battery: **RED clamp to POSITIVE (POS, P or +) terminal and BLACK clamp to NEGATIVE (NEG, N or -) terminal.** Make sure the connections are firm and secure. Good contact is important.

4. If the battery is deeply discharged (and possibly sulphated), remove from the vehicle and inspect the battery before connecting the charger for a recovery attempt. Visually check the battery for mechanical defects such as a bulging or cracked casing, or signs of electrolyte leakage. If the battery has filler caps and the plates within the cells can be seen from the outside, examine the battery carefully to try to determine if any cells seem different to the others (for example, with white matter between the plates, plates touching). If mechanical defects are apparent do not attempt to charge the battery, have the battery professionally assessed.

5. If the battery is new, before connecting the charger read the battery manufacturer's safety and operational instructions carefully. If applicable, carefully and exactly follow acid filling instructions.

OPERATION

OptiMate Solar DUO can charge and maintain the following battery types:

STD : 12V 'wet' cell / refillable lead-acid battery. Liquid acid can leak out if battery is turned on its side.

AGM : 12V sealed lead-acid battery, acid is fully contained within the battery. A 12V AGM battery holds a higher charged voltage than STD lead-acid batteries.

GEL : 12V GEL sealed lead-acid battery, acid is fully contained within the battery. A GEL battery holds similar charged voltages to AGM.

LFP : 12.8V / 13.2V sealed Lithium Ferrous Phosphate battery. Lithium batteries contain no acid. A LFP battery holds a higher charged voltage than AGM / GEL.

Important - OptiMate Solar DUO is suitable ONLY for 4 series cell Lithium Ferrous Phosphate or Lithium Iron Phosphate batteries. DO NOT ATTEMPT TO CHARGE any other type of Lithium battery.

When connected to a solar panel and a battery the OptiMate Solar DUO charge controller will automatically alternate between two program modes, **MONITOR (Night / no sun)** and **CHARGE (Day / sun)**, depending on solar panel's power delivery.

A. MONITOR MODE - When the solar panel stops delivering power (sun has gone down in the evening or cloud covers sun) the OptiMate Solar DUO controller changes to BATTERY MONITOR mode and will now indicate battery charge level every 3 seconds.

LED 2, 3, 4 or 5 indicate battery charge level.



LED:	Voltage:	LFP	AGM (or GEL)	STD
#5 green (double flash)	13.3V +	75% - 100%		
#5 green (single flash)	13.1V - 13.29V	50% - 74%		
#4 blue (double flash)	12.7V - 13.09V	10% - 49%	91% - 100%	
#4 blue (single flash)	12.5 - 12.7V	less than 10%	61 - 90%	90 - 100%
#3 yellow	12.3 - 12.49V		41 - 60%	61 - 90%
#2 red & #3 yellow	12.1 - 12.29V		20 - 40%	40 - 59%
#2 red	Less than 12.1V		Less than 20%	Less than 40%

NOTES: A battery's charge level is directly proportional to the voltage measured across the terminals. Accuracy improves once the battery has cooled to room temperature and has not received further charge for at least 6 hours or more.

Environment temperature affects voltage, the result will worsen as the temperature falls further below 15°C / 60°F.

Some batteries brands may have slightly different voltage and % charge parameters.

B. CHARGE MODE - LED #1 lights if the solar panel can deliver charge. LED #1 flashes when charge current is delivered to the battery. Speed of flashing corresponds to current delivered i.e. fast means high current, slow means low current (cloudy conditions or battery is not accepting high current).

LED 2, 3, 4 or 5 indicate charge progress whilst CHARGE LED #1 is flashing. If no battery is connected only LED #1 turns on.

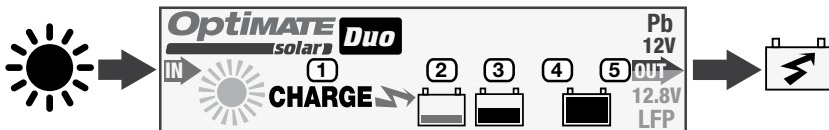

LED ON:	CHARGE MODE:	Description:
LED #2 (RED)	SAVE	Battery save mode in progress - battery is deep discharged / voltage at connection was less than 12V. Max. time: 2 hours
LED #3 (YELLOW)	CHARGE & OPTIMIZE	BULK CHARGE - maximum charge current up to 14.4V OPTIMIZE - final charge is delivered for minimum 10 minutes. Charging may continue if the battery requires further charging. Charge time is affected by strength of sun and size of battery.
LED #4 (BLUE)	MAINTAIN	The battery is receiving maintenance charge up to a maximum voltage of 13.6V.
LED #5 (GREEN)	MAINTAIN	The battery is monitored, holding voltage between 13.3V and 13.6V.

DAILY MAINTENANCE CYCLE: When the solar panel starts delivering power (e.g. in the morning when the sun comes up) the OptiMate Solar controller assesses the battery's charge level to decide the appropriate charge mode.

BATTERY CHARGED, MAINTAIN ONLY: If the battery is sufficiently charged, LED #4 or 5 will immediately light together with LED #1 (flashing).

BATTERY NEEDS CHARGE: If the battery needs further charging LED #2 or LED #3 will light together with LED #1 (flashing).

MULTI-STEP CHARGE MODE: The OptiMate Solar controller automatically alternates between pulse and continuous current mode to always deliver the most efficient and fastest charge. The selected method of current delivery depends on

- 1) Condition of the battery – PULSE : Pulse mode is more effective in saving a battery.
- 2) Power delivered by solar panel –
 - a. PULSE: when the power is low (weak sun / cloud cover) pulses of effective charge current is delivered. Current pulses of 3 – 5 Amps may be delivered, at minimum every 2 seconds.
 - b. CONTINUOUS: when the power received from the panel is sufficient the controller delivers continuous charge current to the battery during the BULK CHARGE mode (LED #3).

NOTES:

1. **Choosing the right size of solar panel:** 12V solar panels are rated according to the maximum output it is able to deliver in direct and full sunlight to a fixed 12V load. Maximum power is rarely achieved; output can drop below 20% in indirect sunlight (e.g. cloud cover). For effective long-term battery maintenance choose a panel that will deliver sufficient current to overcome the parasitic draw of the vehicle circuitry (such as alarm, clock, engine control unit) and return charge lost overnight. Typical parasitic drain: 10-20mA for a motorcycle / power sport vehicle and 30-50mA for a car or pick-up truck fitted with a 12V battery.
2. **24-7 battery maintenance** - The OptiMate SOLAR will maintain a battery whose basic condition is good, for months at a time. At least once every two weeks, check that the connections between the charger and battery are secure, and, in the case of batteries with filler caps on each cell, disconnect the battery from the charger, check the level of the electrolyte and if necessary, top up the cells (**with distilled water, NOT acid**), then reconnect. When handling batteries or in their vicinity, always take care to observe the SAFETY WARNINGS contained in this manual.

THIS PORTION OF THE MANUAL CONTAINS IMPORTANT SAFETY INSTRUCTIONS FOR THE OPTIMATE SOLAR BATTERY CHARGER. IT IS OF THE UTMOST IMPORTANCE THAT EACH TIME, BEFORE USING THE CHARGER, YOU READ AND EXACTLY FOLLOW THESE INSTRUCTIONS. SAVE THESE INSTRUCTIONS.

EN

**AUTOMATIC CHARGER FOR 12V LEAD-ACID &
12.8V LITHIUM FERROUS PHOSPHATE BATTERIES
DO NOT USE FOR NiCd, NiMH, any other type of Li-Ion
OR NON-RECHARGEABLE BATTERIES.**

1. CAUTION : 12V DC APPLIANCE. DO NOT CONNECT TO AC POWER.

- For indoor use only. Do not expose charger to rain or snow.
- Use of an attachment not recommended or sold by the battery charger manufacturer may result in a risk of fire, electric shock, or injury to persons.
- To reduce risk of damage to electric plug and cord, pull by plug rather than cord when disconnecting charger.
- An extension cord should not be used unless absolutely necessary. Use of improper extension cord could result in a risk of fire and electric shock. If extension cord must be used make sure that :
 - pins on plug of extension cord are the same number, size and shape as those of plug on charger.
 - the extension cord is properly wired and in good electrical condition, and
 - the conductor wire size is large enough for the DC ampere rating of the charger as specified in the table below.

DC INPUT RATING IN AMPERES		LENGTH OF CORD, FEET (m)	AWG SIZE OF CORD
Equal to or greater than	But less than		
2A	3A	25 (17.6)	18
		50 (15.2)	16
		100 (30.5)	14

- Do not operate charger with damaged cord or plug - replace the cord or plug immediately.
- Do not operate charger if it has received a sharp blow, been dropped, or otherwise damaged in any way; take it to a qualified serviceman.
- Do not disassemble charger; take it to a qualified serviceman when service or repair is required. Incorrect reassembly may result in a risk of electric shock or fire.
- To reduce risk of electric shock, unplug the charger from supply before attempting any maintenance or cleaning. Turning off controls will not reduce this risk. Clean only with slightly moist, not wet, cloth. Do not use solvents.

10. WARNING – RISK OF EXPLOSIVE GASES.

- WORKING IN VICINITY OF A LEAD-ACID BATTERY IS DANGEROUS. BATTERIES GENERATE EXPLOSIVE GASES DURING NORMAL BATTERY OPERATION. FOR THIS REASON, IT IS OF UTMOST IMPORTANCE THAT YOU FOLLOW THE INSTRUCTIONS EACH TIME YOU USE THE CHARGER.**
- To reduce risk of battery explosion, follow these instructions and those published by the battery manufacturer and manufacturer of any equipment you intend to use in vicinity of the battery. Review cautionary marking on these products and on engine.

11. PERSONAL PRECAUTIONS.

- Someone should be within range of your voice OR close enough to come to your aid when you work near a lead-acid battery.
- Have plenty of fresh water and soap nearby in case battery acid contacts skin, clothing or eyes.
- Wear complete eye protection and clothing protection. Avoid touching eyes while working near battery.
- If battery acid contacts or enters eye, flood eye with cold running water for at least 10 minutes and get medical attention immediately. If battery acid contacts skin or clothing, wash immediately with soap & water. If acid enters an eye, immediately flood eye with running cold water for at least 10 minutes & get medical attention immediately.
- NEVER smoke or allow a spark or flame in vicinity of battery or engine.
- Be extra cautious to reduce risk of dropping a metal tool onto battery. It might spark or short-circuit battery or other electrical part that may cause explosion.
- Remove personal metal items such as rings, bracelets, necklaces, and watches when working with a lead-acid battery. A lead-acid battery can produce a short-circuit current high enough to weld a ring or the like to metal, causing a severe burn.
- NEVER charge a frozen battery.

12. PREPARING TO CHARGE

- If necessary to remove battery from vehicle to charge, always remove grounded terminal from battery first. Make sure all accessories in the vehicle are off, so as not to cause an arc.
- Be sure area around battery is well ventilated while battery is being charged. Gas can be forcefully blown away by using a piece of cardboard or other non-metallic material as a fan.
- Clean battery terminals. Be careful to keep corrosion from coming in contact with eyes.
- Add distilled water in each cell until battery acid reaches level specified by battery manufacturer. This helps purge excessive gas from tanks. Do not overfill. For a battery without cell caps, such as valve regulated lead acid (VRLA) or absorbed glass mat (AGM) batteries, carefully follow manufacturer's recharging instructions.
- Study all battery manufacturer's specific precautions such as removing or not removing cell caps while charging and recommended rates of charge.
- Determine voltage of battery by referring to vehicle or other user's manual and **BEFORE MAKING THE BATTERY CONNECTIONS, MAKE SURE THAT THE VOLTAGE OF THE BATTERY YOU ARE GOING TO CHARGE MATCHES THE OUTPUT VOLTAGE OF THE CHARGER.**

13. CHARGER LOCATION.

- Locate charger as far away from battery as DC cables permit.
- Never place charger directly above battery being charged; gases from battery will corrode and damage the charger.
- Never allow battery acid to drip on charger when reading gravity or filling battery. Do not operate charger in a closed-in area or restrict ventilation in any way.
- Do not set a battery on top of charger. **IMPORTANT:** Place charger on a hard flat surface or mount onto a vertical surface. Do not place on plastic, leather or textile surface.

14. DC CONNECTION PRECAUTIONS

- Connect and disconnect DC output clips only after setting any charger switches to off position and removing DC cord from supply. Never allow clips to touch each other, however should this happen no damage will result to the charger circuit & the automatic charging programme will just reset to «start».
 - Attach clips to battery and chassis as indicated in 15(e), 15(f), and 16(b) through 16(d).
- NOTE : This battery charger has an automatic safety feature that will prevent it from operating if the battery has been inversely connected. Set charger switches to off position and/or remove DC cord from the DC supply, disconnect the battery clips, then reconnect correctly according to the instructions below.

15. FOLLOW THESE STEPS WHEN BATTERY IS INSTALLED IN VEHICLE. A SPARK NEAR A BATTERY MAY CAUSE BATTERY EXPLOSION. TO REDUCE RISK OF A SPARK NEAR BATTERY :

- Position AC and DC cords so as to reduce risk of damage by hood, door or moving engine part.
- Stay clear of fan-blades, belts,pulleys,and other parts that can cause injury to persons.
- Check polarity of battery posts.POSITIVE (POS, P, +) battery post usually has larger diameter than NEGATIVE (NEG, N,-) post.
- Determine which post of battery is grounded (connected) to the chassis. If negative post is grounded to chassis (as in most vehicles), see (e). If positive post is grounded to the chassis, see (f).
- For negative-grounded vehicle, connect POSITIVE (RED) clip from battery charger to POSITIVE (POS, P, +) ungrounded post of battery. Connect NEGATIVE (BLACK) clip to vehicle chassis or engine block away from battery. Do not connect clip to carburetor, fuel lines, or sheet-metal body parts. Connect to a heavy gage metal part of the frame or engine block.
- For positive-grounded vehicle, connect NEGATIVE (BLACK) clip from battery charger to NEGATIVE (NEG, N, -) ungrounded post of battery. Connect POSITIVE (RED) clip to vehicle chassis or engine block away from battery. Do not connect clip to carburetor, fuel lines, or sheet-metal body parts. Connect to a heavy gage metal part of the frame or engine block.
- When disconnecting charger, turn switches to off, disconnect AC cord,remove clip from vehicle chassis,and then remove clip from battery terminal.
- See operating instructions for length of charge information.

16. FOLLOW THESE STEPS WHEN BATTERY IS OUTSIDE VEHICLE. A SPARK NEAR THE BATTERY MAY CAUSE BATTERY EXPLOSION. TO REDUCE RISK OF A SPARK NEAR BATTERY :

- Check polarity of battery posts. POSITIVE (POS, P, +) battery post usually has a larger diameter than NEGATIVE (NEG, N, -) post.
- This battery charger has an automatic safety feature that will prevent it from operating if the battery has been inversely connected. The charger does not allow charge current unless a voltage of at least 1V is sensed.
- Connect POSITIVE (RED) charger clip to POSITIVE (POS, P, +) post of battery.
- Connect NEGATIVE (BLACK) charger clip to NEGATIVE (NEG, N, -) battery post of the battery.
- Do not face battery when making final connection.
- When disconnecting charger, always do so in reverse sequence of connecting procedure & break first connection while as far away from battery as practical.
- A marine (boat) battery must be removed & charged on shore. To charge it on board requires equipment specially designed for marine use.