

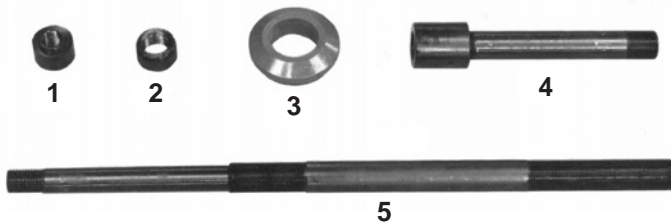

**WARNING:** Wear eye protection that meets ANSI Z87.1 and OSHA standards.

## Hanger Tube & RU Center Bushing Cross Tube Removal Set Application: Hendrickson RU Series Suspensions

The 1743 service set is designed to remove the hanger tube from the end bushings and the cross tube from the center bushings on the RU series suspension. The removal of the hanger tube and cross tube will permit removal of the bushings with the appropriate bushing removal service set. The 1743 service set is designed to be used with the 1740 basic service set.



Item No.	Part No.	No. Req'd	Description
1	25417	1	Nut
2	206455	1	Removing Adapter
3	302015	1	Receiving Adapter
4	302119	1	Special Screw
5	302020	1	Pulling Screw

### CENTER BUSHING CROSS TUBE REMOVAL

**WARNING:** Block the front tires of the vehicle or take the necessary precautions required to prevent movement of the truck during hanger tube or cross tube removal.

*Note: Read all instructions and safety warnings included with any service set.*

1. Remove the saddle caps retaining the center bushing and beam to the spring assembly.
2. Raise the rear of the truck frame until the saddle studs clear the equalizing beam. Use a hole saw to cut out the retaining disc in the center of the bushing. **CAUTION: Do not use a cutting torch to burn out the retaining disc. Otherwise, permanent damage to the equalizing beam may result.**
3. Cut the cross tube between the equalizing beams on the *inside* of both beams as close to the bushing as possible. See Figure 1.
4. Insert the pulling screw (Item 5) through the remaining portion of the cross tube within the bushing and fully thread the nut (1) onto the end of the pulling screw.

**WARNING:** All threads on the nut (1) and speed nut (see Figure 2, next page) must be fully engaged with the threads on the pulling screw (5) before hydraulic pressure is applied.

5. Assemble the pulling screw (5) into the hydraulic component of the 1740 service set. Fully engage the threads of the pulling screw with the nut (1) provided in the hydraulic component set. See Figure 1.
6. Apply hydraulic force to extract the cross tube from the bushing.

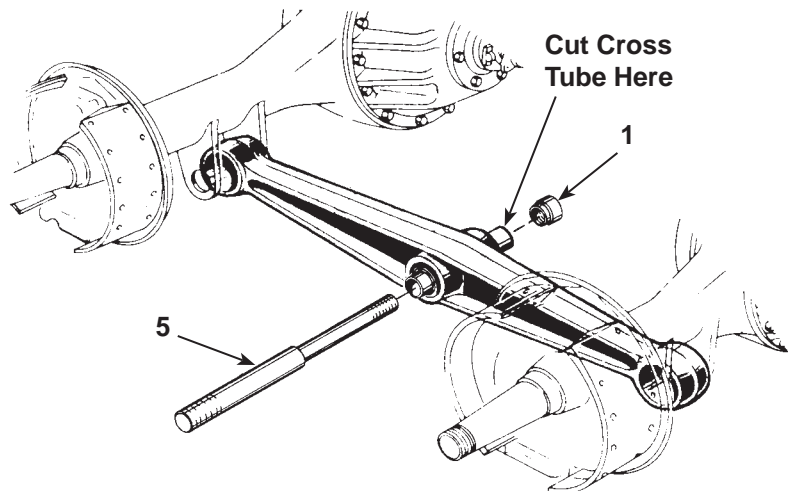

Figure 1

*Note: The center bearing bushing shell will remain. It must be removed with the appropriate bushing removal service set. The center bushing removal operation can be set up and completed at this time.*

# Parts List & Operating Instructions

## END BUSHING HANGER TUBE REMOVAL

The following procedure requires that tires, brakes, and backing plates be removed from the vehicle to permit access to the end bushing area.

*Note: Some of the RU series suspensions are equipped with end beam adapter plugs. An OTC End Bushing Adapter Puller Set No. 1745 is required to remove the adapters.*

1. Thread the special screw (Item 4) onto the end of the pulling screw (5). See Figure 2.
2. Remove the retaining nuts from the hanger tube on the vehicle. See Figure 3.

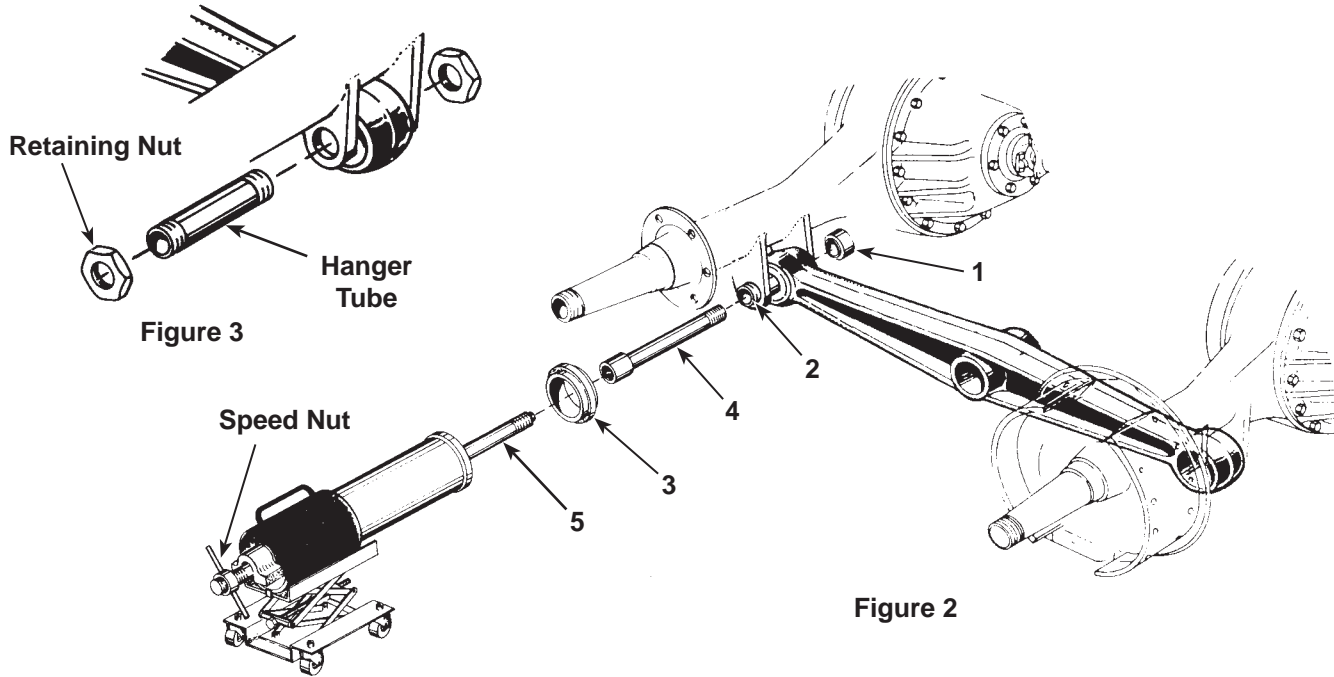

3. Insert the special screw (4) into the hanger tube and thread nut (1) onto the special screw as shown in Figure 4.
4. Install the receiving adapter (3) on the cylinder receiving tube as shown in Figure 5.

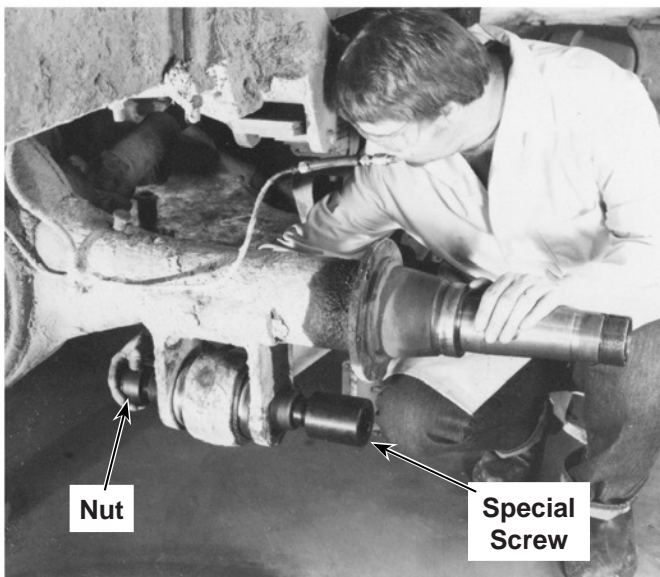

Figure 4

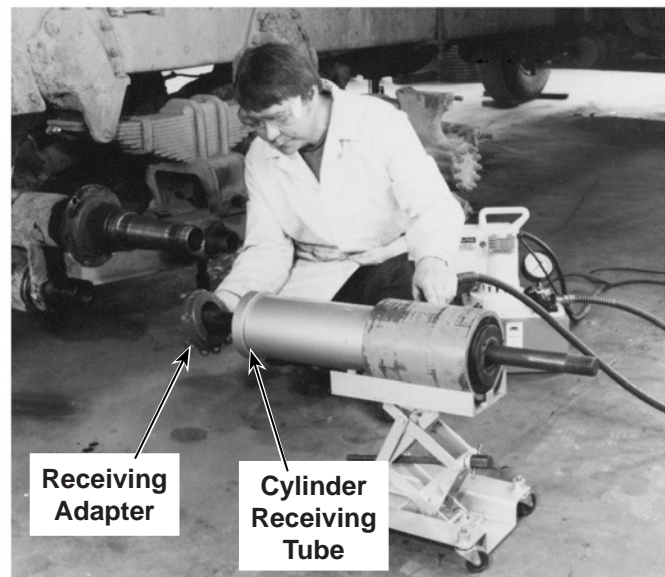

Figure 5

**End Bushing Hanger Tube Removal (Continued)**

5. With the pulling screw (Item 5) inserted through the hydraulic cylinder, position the cylinder so the end of the pulling screw aligns with the special screw (4) installed earlier. Then thread the pulling screw into the special screw. See Figure 6.
6. Position the hydraulic cylinder assembly up against the beam face, as shown in Figure 7. Install the speed nut on the hydraulic cylinder and adjust the nut to take up any slack. Then apply hydraulic force to extract the hanger tube.

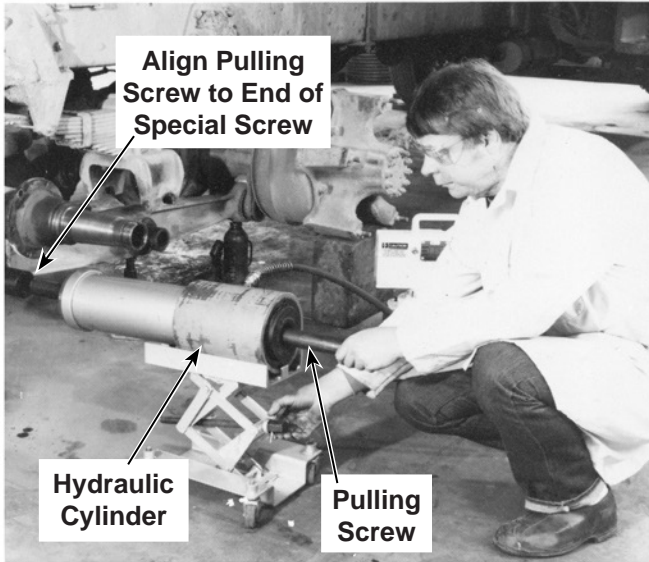

Figure 6

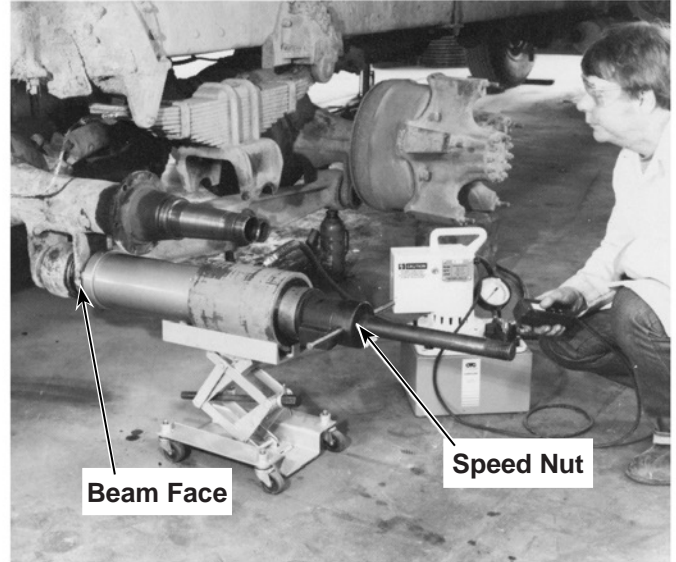

Figure 7