

Caterpillar Diesel Mounting Plate Application Charts

(used with OTC #1750A Diesel Engine Repair Stand)

Mounting Plate No.	Used On
217687	3114 Inline 4 3116 & 3176 Inline 6



WARNING: To prevent personal injury,



- Wear eye protection that meets ANSI Z87.1 and OSHA standards.



- Tighten all mounting screws and bolts before starting work on the engine.

- Use only SAE Grade 8 cap screws to mount the plate to the engine and to the engine support.

Installation Instructions

1. Bolt the mounting plate to the engine as shown in one of the following application charts.
2. Find the engine's center of balance (or greatest concentration of weight). *Note: This is usually about two inches above the center of the crankshaft.* See Figure 1.
3. Attach side plates to the engine mounting adapter plate, but leave the cap screws and nuts loose.
4. Align the engine (with side plates attached to the adapter plate) with the universal mounting adapter plate. Raise or lower the engine until its center of balance is in-line with the rotating shaft of the engine stand.
5. Align the closest tapped holes in the universal mounting adapter plate with the holes in the side plates. Securely tighten the side plates to the engine mounting plate and to the universal mounting adapter plate on the engine stand.

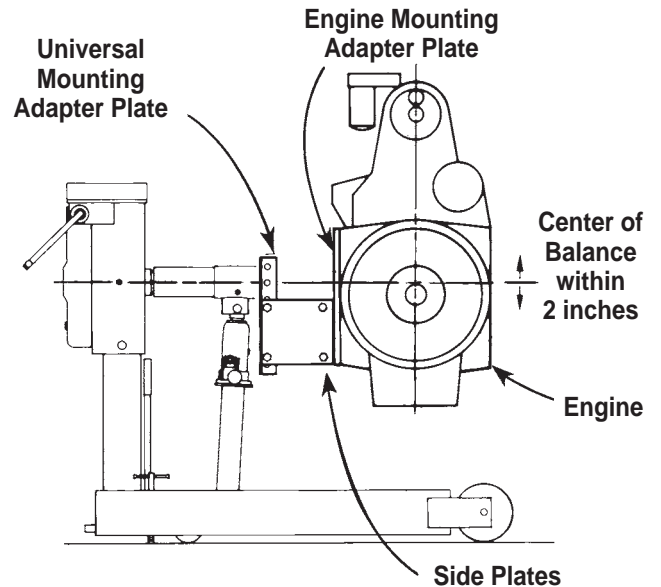

Figure 1

Fasteners	Description	Qty.	Part No.
Cap Screws	M8 x 1.25 x 35 mm lg.	1	211993
	M14 x 2 x 40 mm lg.	1	217684
	M10 x 1.5 x 35 mm lg.	3	217685
	M12 x 1.75 x 70 mm lg.	3	217686
Washers	M10 Bolt Size	3	10231
	M14 Bolt Size	1	10234
	M8 Bolt Size	1	10257
	M12 Bolt Size	3	10586
Spacers	1-1/4 O.D. x 17/32 I.D. x 1-3/8 lg.	3	217682

Application Charts & Installation Instructions

Model 3114

TOP

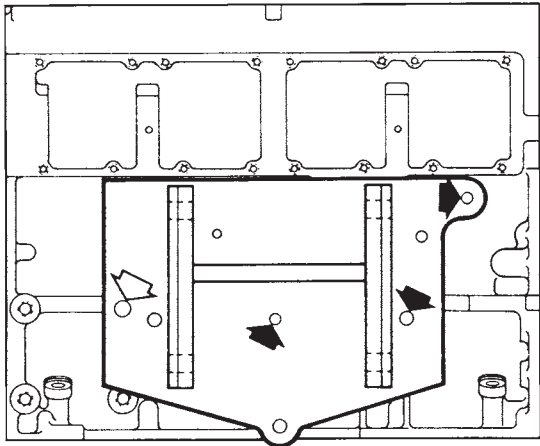

- ▶ (3) M10 x 1.5 x 35mm Lg. Cap Screw, Grade 10.9
- ▶ (3) M10 Washer
- ◁ (1) M14 x 2 x 40mm Lg. Cap Screw, Grade 10.9
- ◁ (1) M14 Washer

Model 3116

TOP

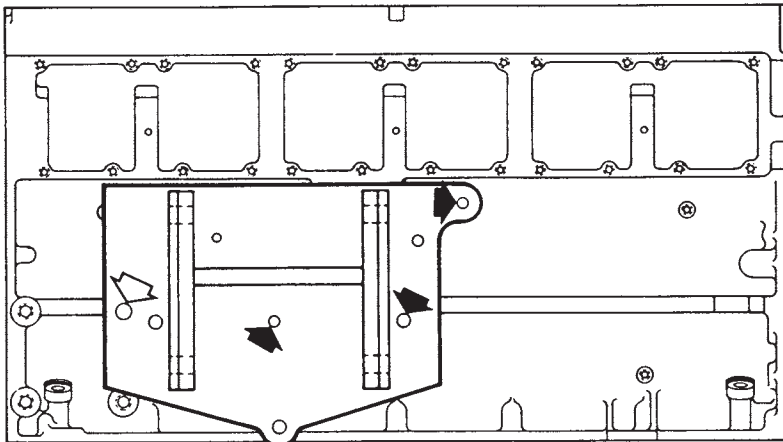

- ▶ (3) M10 x 1.5 x 35mm Lg. Cap Screw, Grade 10.9
- ▶ (3) M10 Washer
- ◁ (1) M14 x 2 x 40mm Lg. Cap Screw, Grade 10.9
- ◁ (1) M14 Washer

Model 3176

TOP

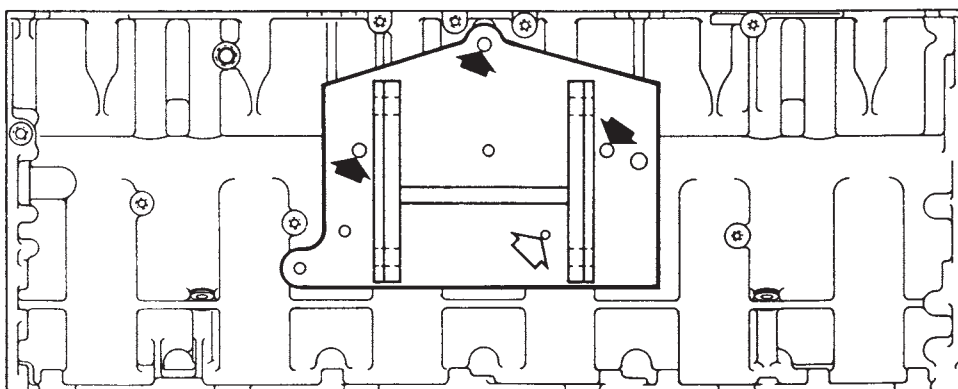

- ▶ (3) M12 x 1.75 x 70mm Lg. Cap Screw, Grade 10.9
- ▶ (3) 1-1/4 OD x 17/32 ID x 1-3/8 Lg. Spacer
- ▶ (3) M12 Washer
- ◁ (1) M8 x 1.25 x 35mm Lg. Cap Screw, Grade 10.9
- ◁ (1) M8 Washer