

Mounting Plate Application Chart

(for OTC #1750A Diesel Engine Repair Stand)

Mounting Plate No.	Used On
218099	Cummins "C" Series

Installation Instructions

1. Bolt the mounting plate to the engine as shown in the application chart.
2. Find the engine's center of balance (or greatest concentration of weight). *Note: This is usually about two inches above the center of the crankshaft.* See Figure 1.
3. Attach side plates to the engine mounting adapter plate, but leave the cap screws and nuts loose.
4. Align the engine (with side plates attached to adapter plate) with the universal mounting adapter plate. Raise or lower the engine until its center of balance is in-line with the rotating shaft of the engine stand.
5. Align the closest tapped holes in the universal mounting adapter plate with the holes in the side plates. Securely tighten the side plates to the engine mounting plate and to the universal mounting adapter plate on the engine stand.

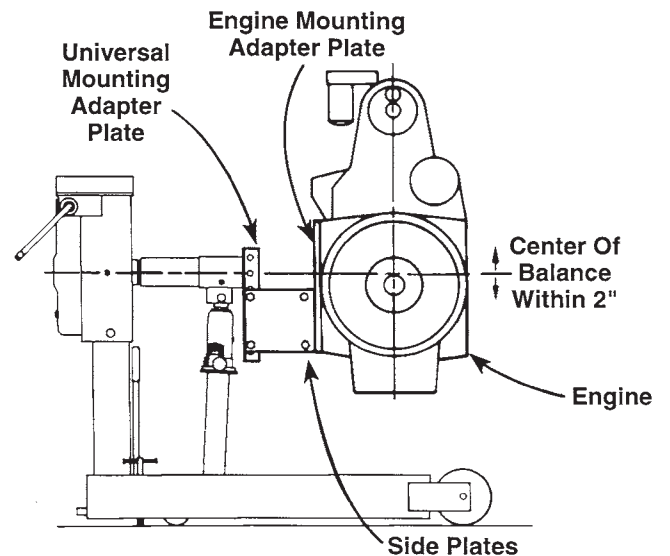

Figure 1

Fasteners:

Item	Description	Qty.	Part #
Cap Screws	M8 x 1.25 x 25 mm Lg.	2	218097
	M10 x 1.5 x 30 mm Lg.	4	218096
	M12 x 1.75 x 30 mm Lg.	2	19848
Washers	M8 Bolt Size	2	10257
	M10 Bolt Size	4	10231
	M12 Bolt Size	2	10586



WARNING:

- To help prevent personal injury,
- Wear eye protection that meets the requirements of ANSI Z87.1 and OSHA.
 - All mounting screws and bolts **MUST** be tight before starting work on the engine.
 - Use only SAE Grade 8 (or Metric Grade 10.9) cap screws to mount the plate to the engine and to the engine repair stand.

Cummins "C" Series Engine

