

# Transfer Tanker

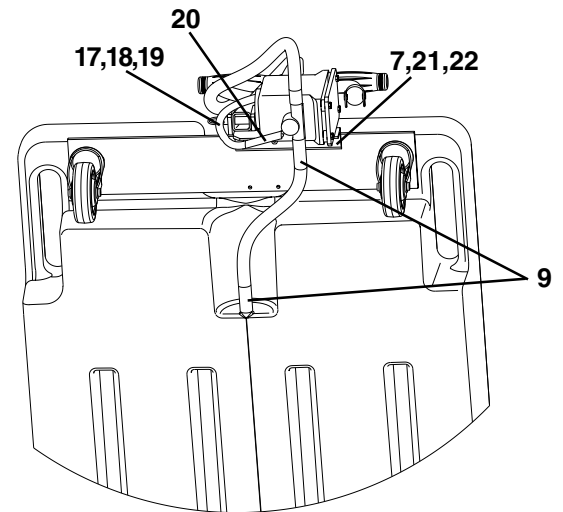

**Maintenance:** Keep the reservoir clean, and free of grit and grease.

## Bottom View with Straps

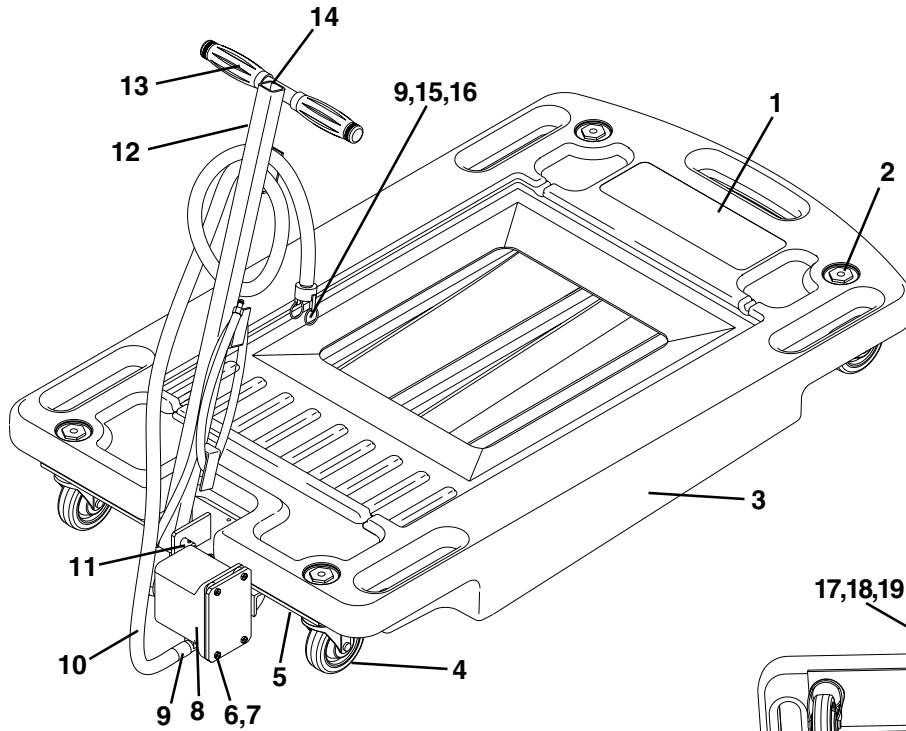
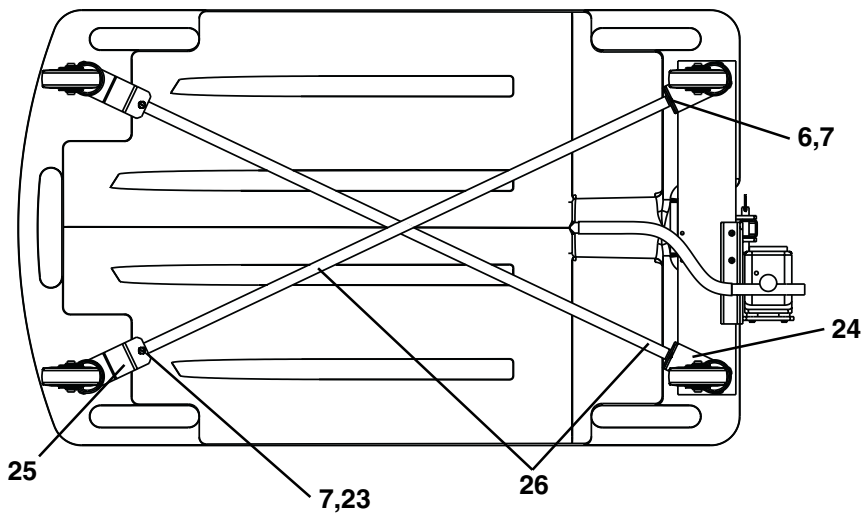

# Parts List & Operating Instructions

---

## Parts List

Item No.	Part No.	No. Req'd	Description
1	529967	1	Logo/Warning Decal
2	528090	4	Threaded Insert
3	528089	1	Oil Reservoir
4	210973	4	Swivel Caster (4")
5	528208	1	Handle Mount
6	11856	6	Round Head Machine Screw
7	207405	10	Hex Locknut
8	529966	1	Pump
9	12367	4	Hose Clamp (.68-1.25)
10	222685	1	Tubing
11	15997	1	Cotterless Hitch Pin
12	54555	1	Handle
13	18267	2	Handle Grip
14	207655	1	Cap
15	222682	1	Hose Fitting
16	222684	1	Fitting Cap
17	216260	3 ft.	Air Hose
18	207201	1	Hose Fitting (1/4 NPT F, 1/4 Barb)
19	12247	1	Quick-coupler Plug
20	210331	2	Hose Clamp
21	529109	1	Pump Bracket
22	10167	2	Round Head Machine Screw
23	10166	2	Machine Screw
24	531394	2	Front Plate
25	531395	2	Rear Plate
26	531396	2	Strap

### Included But Not Shown

222693	1	Filter Screen
J-41329-10	4	Screw (#10 x 3/4 Long)

## Safety Precautions

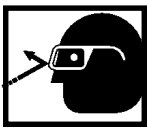

**CAUTION:** To prevent personal injury,

- Wear eye protection that meets ANSI Z87.1 and OSHA standards.
- Do not transport flammable, volatile fluids. The transfer tanker has an electric pump, which could cause a fire or an explosion.



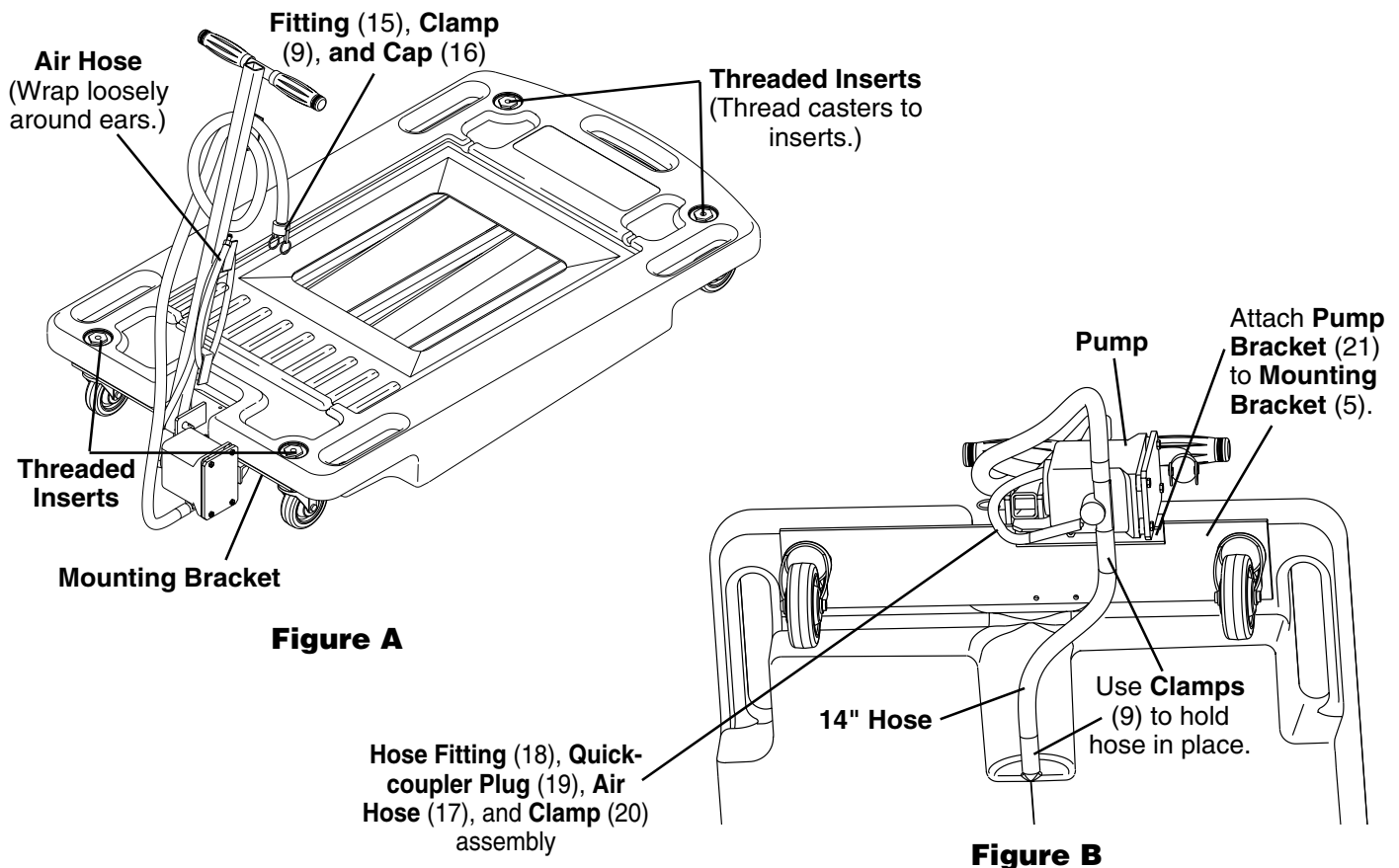

### Assembly Instructions

(Refer to parts lists for item numbers in brackets.)

1. Mount the pump bracket to the handle mount using two screws (22) and locknuts (7).
2. From the top of the reservoir, install the four threaded inserts (see Figure A).
3. From the bottom of the reservoir, attach the handle mount (5) using the two front plates (24) and two casters. Insert the caster studs through the large holes in the front plates and through the slots in the handle mount. Install the caster studs into the front threaded inserts (hand tighten only).
4. Attach a strap to each of the rear plates (25) using a screw (23) and a locknut (7). **Note:** The direction of the screws must point away from the reservoir.
5. Insert the caster studs through the holes in the rear plates, and then install the caster studs into the rear threaded inserts (hand tighten only).
6. Position the straps as shown in the illustration on Sheet 1 of 2. Attach the straps to the front plates using screws (6) and locknuts (7). **Note:** The screws must be installed with the nut on the same side as the strap.
7. Mount the pump to the pump bracket using four screws (6) and locknuts (7).
8. Cut a 14" piece of hose from the tubing (10), and install the hose between the fitting on the reservoir and the pump inlet using two hose clamps (9).
9. Attach the hose fitting and the quick-coupler plug to the air hose using a clamp (20).
10. Clamp the air hose to the air inlet on the pump using a hose clamp (20) (see Figure B).
11. Install the cap (14) and grips (13) to the handle. Attach the handle to the handle mount using the cotterless hitch pin (11).
12. Attach the remaining hose to the outlet side of the pump with a hose clamp (9).
13. Attach the hose fitting (15) to the hose with a hose clamp (9), and install the fitting cap (16) (see Figure A). Wrap the hoses around the handle ears leaving slack to enable handle movement without damaging the hoses.
14. Attach the screen to the reservoir by installing a self-tapping screw through a hole in each corner of the screen.

#### Rear Caster / Plate

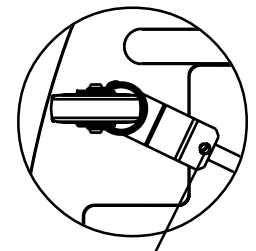

Place locknut on this side of plate.