

**Operating Instructions
for:****5191**

Bearing Cup Installer

140 Series, 170 Series, or 250 Series Driveline

1. Select the adapter that fits the series of driveline to be assembled. Install the adapter into the end of the forcing screw.
2. Position the U-joint cross and one bearing cup into the driveline by hand. Verify the grease fitting is in the correct position.
3. Reverse the forcing screw until it is possible to position the tool over the yoke.
4. By hand, tighten the forcing screw until the frame of the tool is contacting the yoke, and the bearing cup is positioned correctly into the recess of the adapter.
5. Using an impact or hand wrench, begin applying force to press the bearing cup into the yoke.
6. When the adapter is completely tight against the yoke, stop applying force, and reverse the forcing screw.
7. Hand install the second bearing cup into the yoke. Verify the U-joint cross is in the correct position between both cups. Repeat Steps 4 — 6.

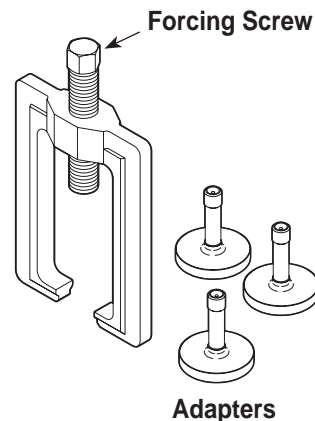

CAUTION: To prevent personal injury, wear eye protection that meets ANSI Z87.1 and OSHA standards.