

52871

## MOUNTING PLATE APPLICATION CHART

FOR OTC NO. 1750 DIESEL ENGINE REPAIR STAND

This mounting plate is designed to service Detroit Diesel 6V and 8V Series 71 Coach Engines.

### WARNING

- Use only Grade 8 cap screws when mounting plate to the engine repair stand. A lesser grade cap screw may shear, possibly resulting in personal injury.
- To help prevent personal injury, check all mounting screws and bolts to insure that they have been adequately tightened.

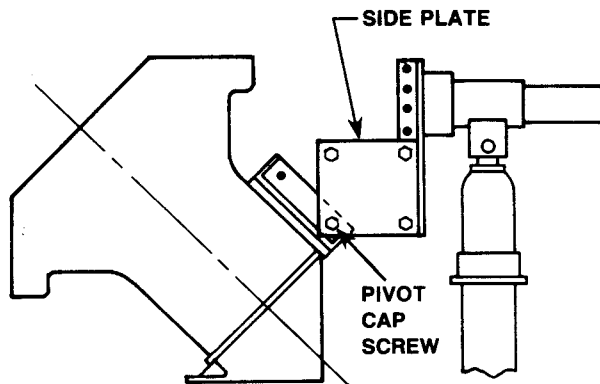

Fig. 1

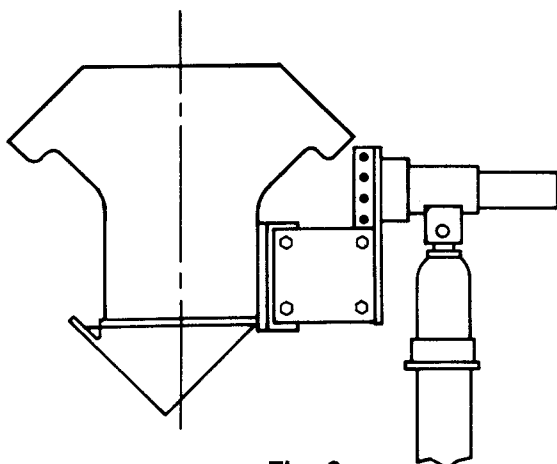

Fig. 2

### IMPORTANT MOUNTING INFORMATION:

1. After the engine has been lifted out of the vehicle, attach the Mounting Plate to the side of the engine as shown in Figures 3 & 4.
2. Attach the Mounting Plate to the side plate of the 1750 Diesel Engine Repair Stand as shown in Figure 1.
3. To finish attaching the engine to the Engine Stand, the engine must be turned 45°. Hook a second lifting device to the opposite side of the engine. Swing the engine into an upright position by pivoting on the bottom cap screw. Install the top cap screw as shown in Figure 2. Securely tighten the side plates to the engine mounting plate and to the universal mounting adapter plate on the engine stand.

# Parts List and Operating Instructions

## MODEL 6V-71 RIGHT SIDE OF BLOCK

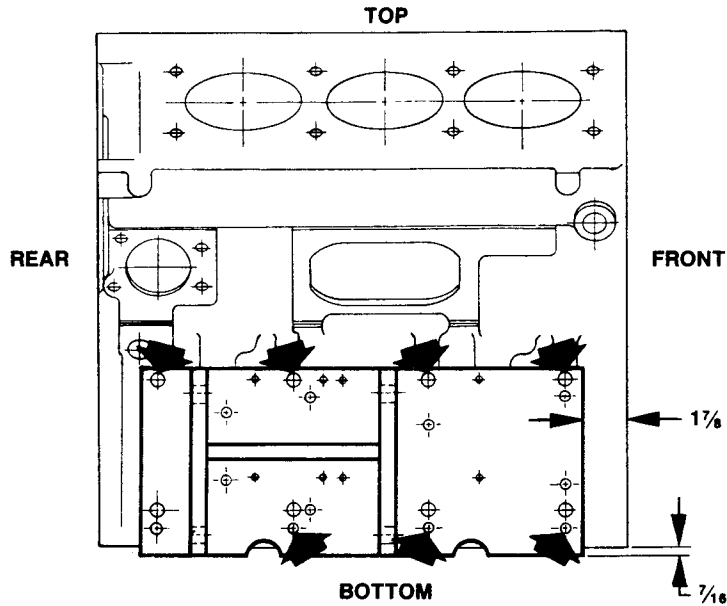

Fig. 3

- ▶ (7)  $\frac{3}{8}$ -16 UNC  $\times$  1 1/2 Lg. Cap Screw, Grade 8 (#19818)
- ▶ (7)  $\frac{3}{8}$ " Washer (#10231)

## MODEL 8V-71 RIGHT SIDE OF BLOCK

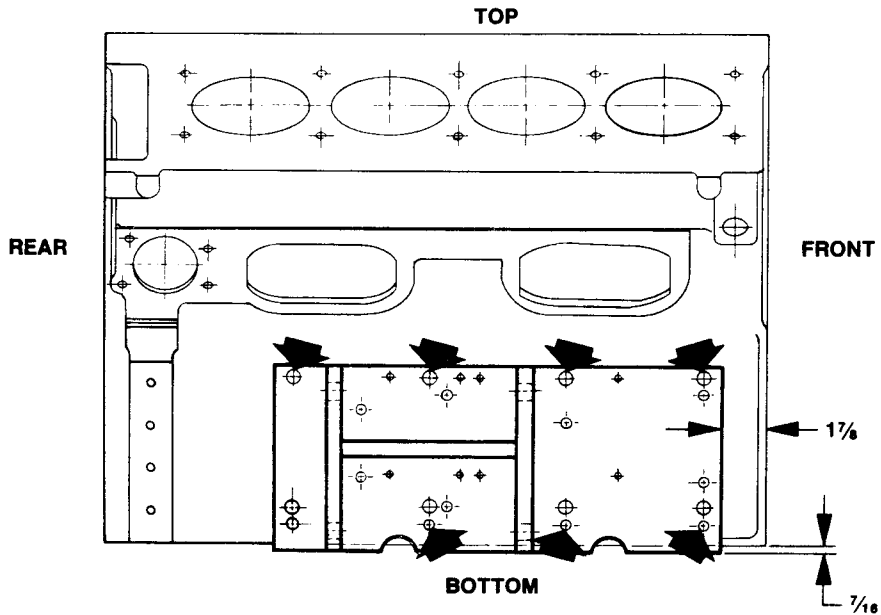

Fig. 4

- ▶ (7)  $\frac{3}{8}$ -16 UNC  $\times$  1 1/2 Lg. Cap Screw, Grade 8 (#19818)
- ▶ (7)  $\frac{3}{8}$ " Washer (#10231)