



Component for OTC No. 1750 or No. 1750A

Engine Mounting Adapter

Maximum Capacity: 1360 kg (3000 lbs.)

Tool Weight: 56 kg (123 lbs.)

Description: Engine mounting adapter designed for mounting John Deere 400-Series, 500-Series, and 6090-Series engines to OTC 1750 and 1750A Heavy-Duty Engine Repair Stands.

Attach No. 51400 Adapter to No. 60581 Engine Mounting Adapter

Use the four hex head cap screws (No. 19654) provided. Torque to 136 N•m (100 ft. lbs.)

Note: No. 51400 is needed in all setups except the 400 Series 4-cylinder engines, which require only the No. 60581.

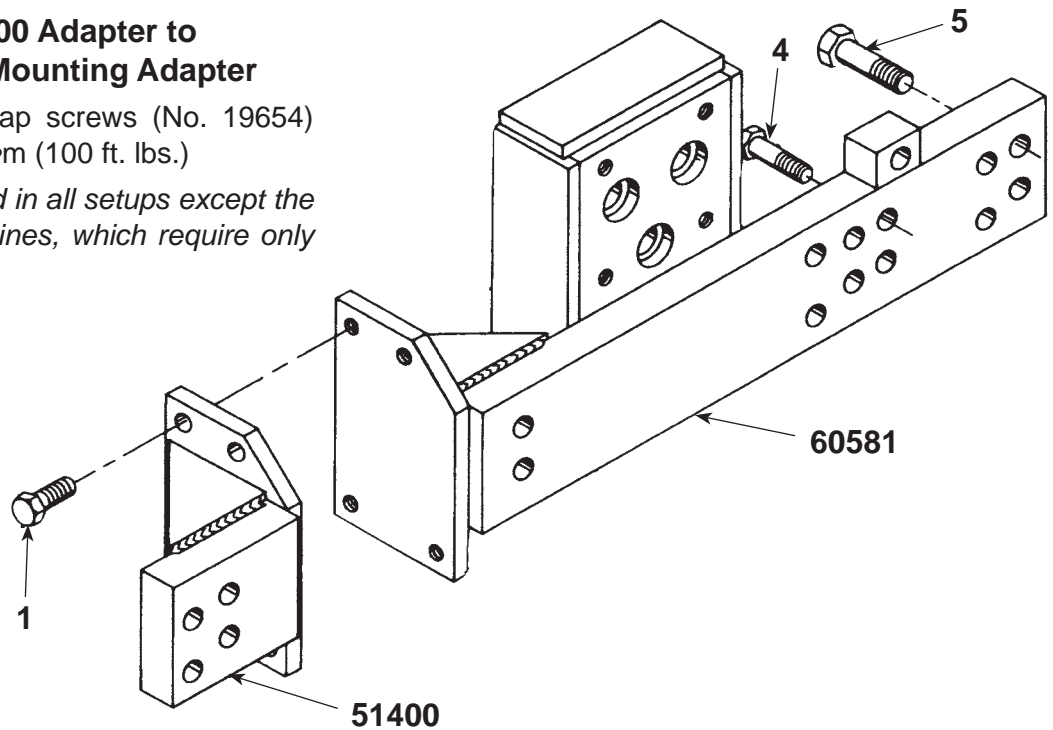

Parts List

Item No.	Part No.	No. Req'd	Description
1	19654	4	Hex Head Cap Screw— 5/8-11 x 38.1 mm (1-1/2 in.) lg.
2	51400	1	End Adapter
3	60581	1	Engine Mounting Adapter
4	19656	5	Hex Head Cap Screw— 5/8-11 x 69.9 mm (2-3/4 in.) lg.
5	19657	5	Hex Head Cap Screw— 3/4-10 x 69.9 mm (2-3/4 in.) lg.

Note: No. D05223ST Engine Repair Stand consists of No. 205466 Engine Mounting Adapter and No. 1750 Engine Repair Stand. Refer to Form No. 100300 for information regarding the engine repair stand.

Parts List & Operating Instructions

Explanation of Safety Signal Words

The safety signal word designates the degree or level of hazard seriousness.



DANGER: Indicates an imminently hazardous situation which, if not avoided, will result in death or serious injury.



WARNING: Indicates a potentially hazardous situation which, if not avoided, could result in death or serious injury.



CAUTION: Indicates a potentially hazardous situation which, if not avoided, may result in minor or moderate injury.

CAUTION: Used without the safety alert symbol indicates a potentially hazardous situation which, if not avoided, may result in property damage.

Safety Precautions



CAUTION: To prevent personal injury and/ or property damage,



- Study, understand, and follow all safety precautions and operating instructions before using this engine mounting adapter. If the operator cannot read instructions, operating instructions and safety precautions must be read and discussed in the operator's native language.

- Only qualified operators may install, operate, adjust, maintain, clean, repair, inspect, or transport this engine mounting adapter.



- Wear eye protection that meets ANSI Z87.1, CE EN166, AS/NZS 1337, and OSHA standards.

- Do not exceed the rated capacity shown on the engine mounting adapter.

- To maintain shear strength specifications, use SAE grade 8 or property class 10.9 hex head cap screws to mount components or engines.

- Use this engine mounting adapter with OTC No. 1750 or No. 1750A Heavy-Duty Engine Repair Stand only.

- Do not use this engine mounting adapter for anything other than its intended purpose.

- No alteration shall be made to this product.

- Inspect the condition of the engine mounting adapter before each use; do not use if damaged, altered, or in poor condition.

- Use only those repair parts called out in the parts list in this document. Items found in the parts list have been carefully tested and selected by OTC.

Preventive Maintenance



CAUTION: To prevent personal injury,

- Only qualified personnel shall perform inspections and repairs to this engine mounting adapter.
- Before each use, an approved inspector must inspect the engine mounting adapter for bends, cracks, dents, elongated holes, or missing hardware. If damage is found, discontinue use.
- Use only those repair parts called out in the parts list in this document. Items found in the parts list have been carefully tested and selected by OTC.

Operating Instructions

1. Mount the engine adapter to OTC No. 1750 or 1750A Heavy-Duty Engine Repair Stand using the three 1–8 UNC socket head cap screws included with the engine repair stand.
 2. Torque cap screws to 610 N•m (450 ft. lbs.) using the hex adapter included with the engine repair stand.
- Refer to the John Deere service manual, OTC form No. 102302, and the decal on the engine repair stand for more information regarding load ratings and other specifications when mounting engines or components to the engine repair stand.



CAUTION: To prevent personal injury, NEVER remove overhead lifting equipment until the engine is securely mounted to the repair stand and all mounting hardware is tightened to a specified torque. Release the overhead lifting equipment carefully and slowly.

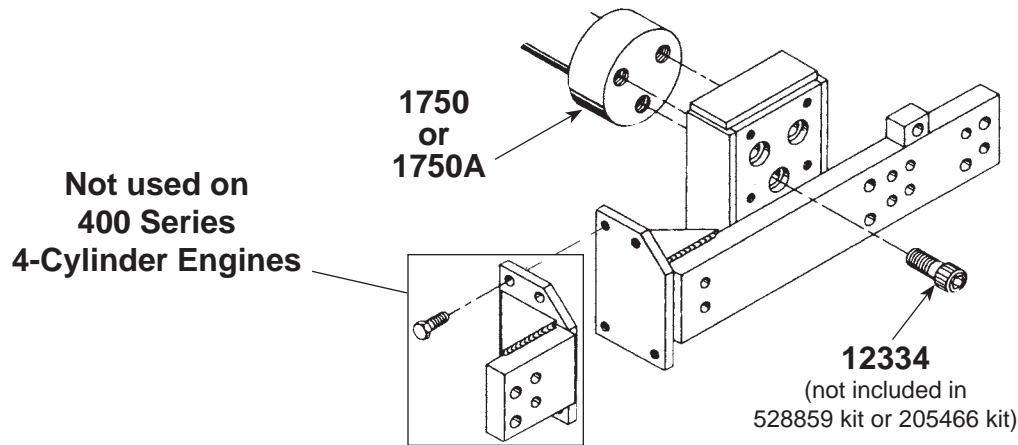

Mount the Engine to an Adapter and/or Engine Stand

Choose one of the following setups to attach the engine mounting adapter to a 400-, 500-, or 6090-Series engine.

400 Series (4-270) 4-Cylinder Engines

NOTE: Some 400 series 4-cylinder short blocks use 3/4-10 UNC x 69.9 mm (2-3/4 in.) hex head cap screws.

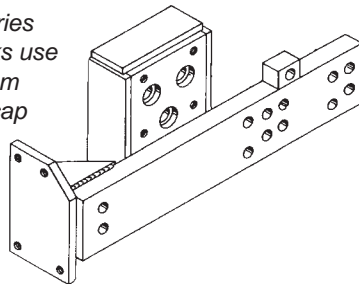

Mount No. 60581 to the starter side of the engine **without** No. 51400 end adapter.

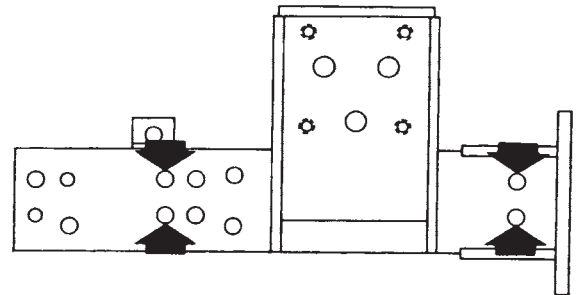

- Use four 5/8-11 UNC x 69.9 mm (2-3/4 in.) lg. hex head cap screws as shown.
- Minimum thread engagement required: 31.75 mm (1-1/4 in.)
- Torque to 136 N•m (100 ft. lbs.).

Parts List & Operating Instructions

400 Series (6-404) 6-Cylinder Engines

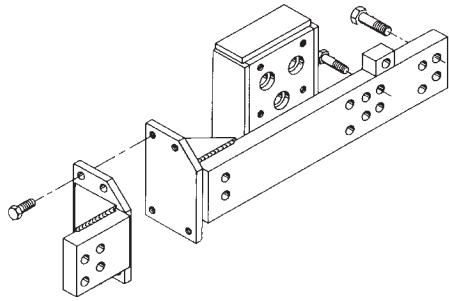

Mount No. 60581 to the starter side of the engine **with** No. 51400 end adapter in place.

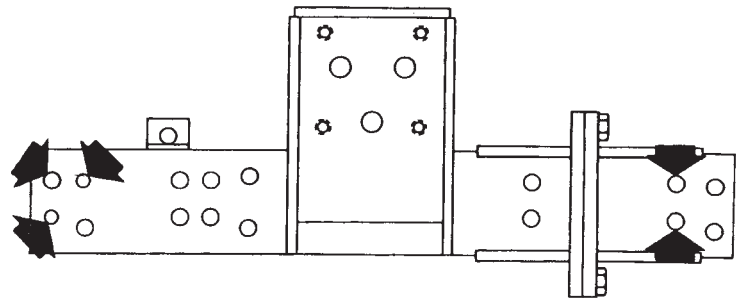

- Use five 5/8-11 UNC x 69.9 mm (2-3/4 in.) lg. hex head cap screws as shown.
- Minimum thread engagement required: 31.75 mm (1-1/4 in.)
- Torque to 136 N•m (100 ft. lbs.).

400 Series (6-466) 6-Cylinder Engines

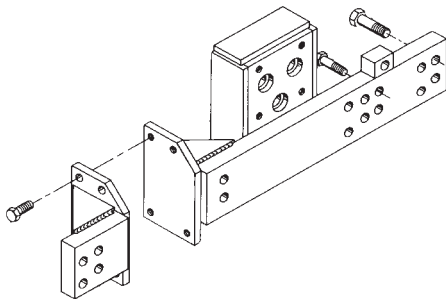

Mount No. 60581 to the starter side of the engine **with** No. 51400 end adapter in place.

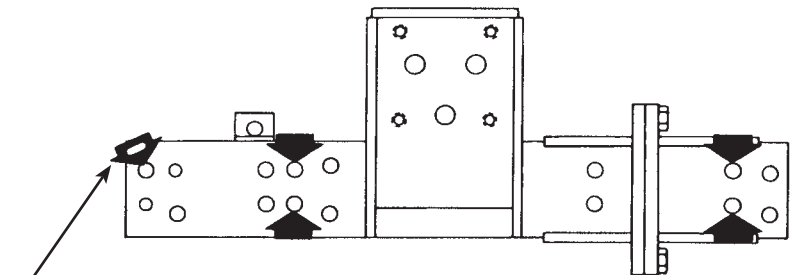

- Use one 3/4-10 x 69.9 mm (2-3/4 in.) lg. hex head cap screw as shown.
 - Minimum thread engagement required: 38 mm (1-1/2 in.)
 - Torque to 203 N•m (150 ft. lbs.).
-
- Use four 5/8-11 UNC x 69.9 mm (2-3/4 in.) lg. hex head cap screws as shown.
 - Minimum thread engagement required: 31.75 mm (1-1/4 in.)
 - Torque to 203 N•m (150 ft. lbs.).

500 Series 6-Cylinder Engines

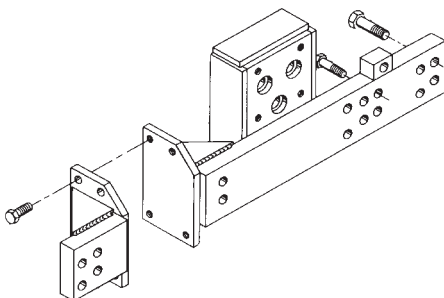

Mount No. 60581 to the starter side of the engine **with** No. 51400 end adapter in place.

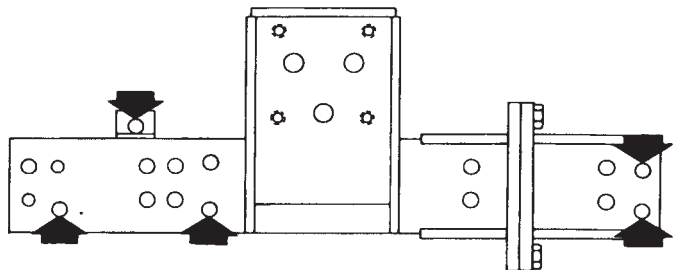

- Use five 3/4-10 x 69.9 mm (2-3/4 in.) lg. hex head cap screws as shown.
- Minimum thread engagement required: 31.75 mm (1-1/4 in.)
- Torque to 203 N•m (150 ft. lbs.).

6090 Series Engines

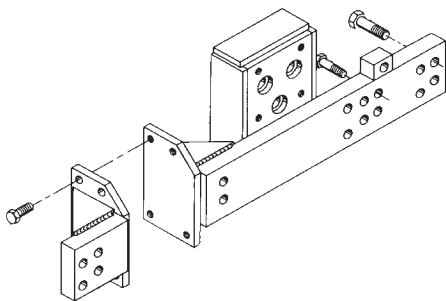

Mount No. 60581 to the starter side of the engine **with** No. 51400 end adapter in place.

Note: If the starter motor or crankshaft driven auxiliary drive accessory is to be removed from the engine, remove it before mounting the engine onto the repair stand.

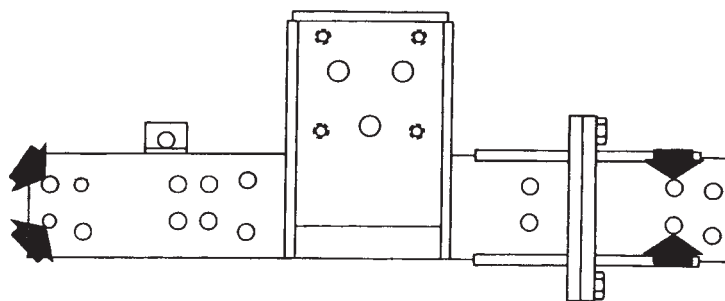

- Use four M16 x 2.0 x 110 mm Class 10.9 or higher (Grade 8) hex head cap screws as shown.
- Minimum thread engagement required: 31.75 mm (1-1/4 in.)
- Torque to 225 N•m (165 ft. lbs.).