

**Parts List &  
Operating Instructions**  
for:

**7045B**

## Front Coil Spring Compressor

Application: GM, Ford, or Chrysler

*(Late model rear wheel drive vehicles with front coil springs mounted between upper & lower control arms)*

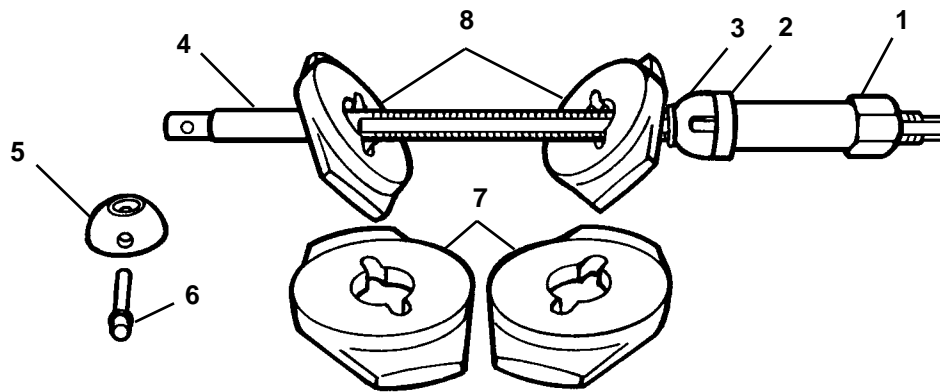

### Parts List

Item No.	Part No.	No. Req'd	Description
1	37666	1	Barrel Nut
2	211206	1	Thrust Bearing
3	311835	1	Lower Ball
4	49169	1	Threaded Rod
5	37731	1	Upper Ball
6	204444	1	Pin
7	42912-BK2	2	Support Plate (large)
8	42913-BK2	2	Support Plate (small)

### Safety Precautions



**Caution:** To help prevent personal injury,

- Wear eye protection that meets the requirements of ANSI Z87.1 and OSHA.
- Check the condition of the spring compressor before each use; do not use the spring compressor if it is in poor condition.
- Do not drop the tool while it is holding a compressed spring.

# Parts List & Operating Instructions

## Operating Instructions

(Item numbers refer to the parts list.)

### Removing the Spring

1. Remove the nuts and washers on top of the shocks.
2. Raise the vehicle on a frame-type hydraulic lift. Remove the wheels and shock absorbers.
3. Determine which support plates (large or small) fit the I.D. of the coil spring to be removed.
4. Install the first support plate (#7 or #8) midway in the spring with the ball cavity positioned UP. See Figure 1.
5. Install the second support plate (of the same size) as close to the bottom of the spring as possible, with the ball cavity positioned DOWN.
6. Place the threaded rod (#4) through the support plates, cross hole end first.
7. Install the upper ball (#5) between the coils of the spring, above the upper support plate, and over the threaded rod. Align the holes in the upper ball with the cross hole in the threaded rod, and install the pin (#6).
8. Lay the upper ball down into the upper support plate ball cavity so the pin nests in the slot in the plate.
9. Wind the upper support plate up to the top of the spring using the threaded rod as a driver.
10. Slip the lower ball onto the threaded rod from the end, passing through the shock absorber opening, and seating in the lower support plate ball cavity.  
**Note: The tang on the lower ball must nest in the slot in the lower support plate.**
11. Place the thrust bearing (#2) on the threaded rod, and follow with the barrel nut (#1), threaded end first. Figure 2 shows the tool correctly assembled on the front coil spring.

**Important: The pin in the upper ball and the tang on the lower ball prevent the support plates and threaded rod from turning under load.**

- Verify that the pin in the upper ball is in the support plate slot.
- Verify that the tang in the lower ball is in the support plate slot.

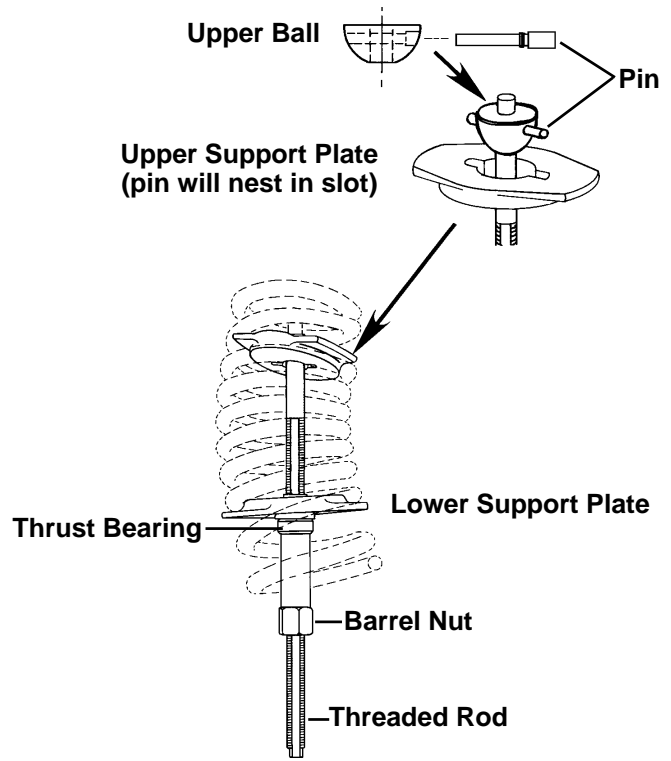

Figure 1

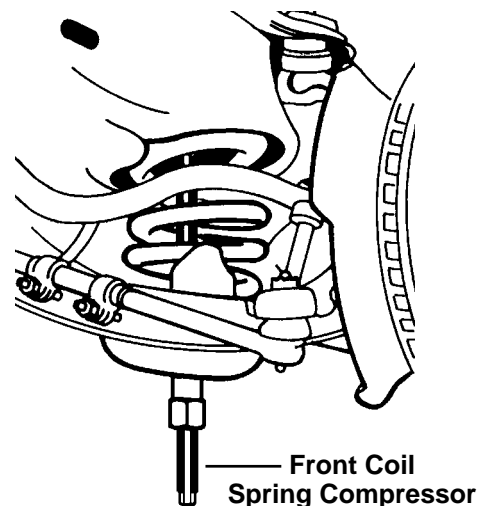

Figure 2

**Removing the Spring cont'd**

12. Use a 1/2" wrench on the flats of the threaded rod to hold the threaded rod. Use a 1-1/4" wrench to turn the barrel nut and compress the spring until it just begins to rotate.
13. Remove the lower control arm pivot bolts. Disengage the lower control arm from the frame. See Figure 3.
14. Remove the compressed spring and the front coil spring compressor as an assembly.
15. Measure the compressed length of the spring, and count the number of coils between the support plates. See Figure 4. Record this data, because it will be used to determine the correct location of the support plates in the new spring.
16. Hold the threaded rod with a 1/2" wrench to keep it from turning. Using a 1-1/4" wrench, loosen the barrel nut to release tension.

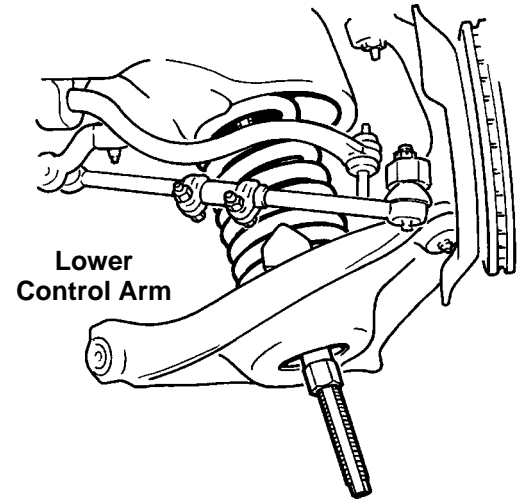

Figure 3

**Installing the New Spring**

1. Insert the threaded rod into the new coil spring. Refer to the data recorded in Step 15, and install the support plates in the same locations as in the old spring. Assemble the lower ball, thrust bearing, and barrel nut.
2. Verify that the new spring has the correct number of coils between the support plates as recorded in Step 15.
3. Compress the coil spring to the original measured height.
4. Refer to the vehicle service manual, and follow the procedure to install the new spring.

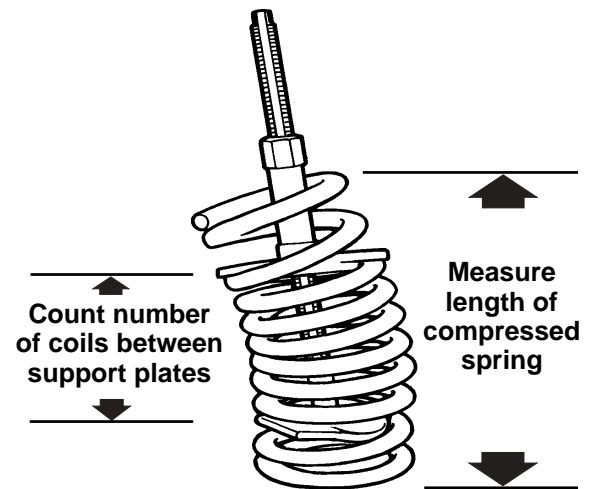

Figure 4

**Removing the Tool from the Spring**

1. SLOWLY loosen the barrel nut until the spring is no longer under tension.
2. Remove the barrel nut, thrust bearing, and lower ball from the threaded rod.
3. Turn the threaded rod until the upper plate winds down the coil spring far enough so the pin can be removed from the upper ball seat.
4. Remove the upper support plate, the upper ball, and the threaded rod.

**Maintenance**

1. Each time before the tool is used, clean and lubricate the threads on the threaded rod.