

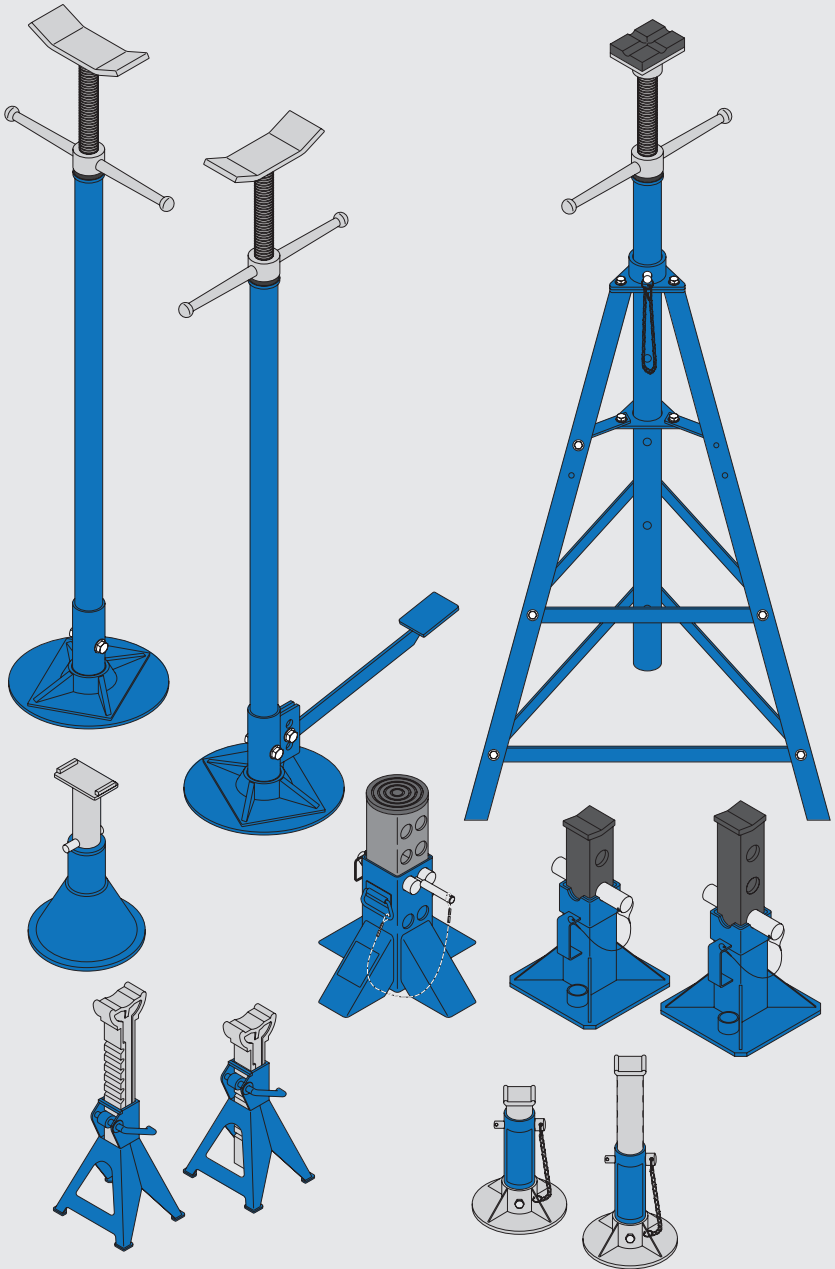

JACK STAND INSTRUCTIONS





About OTC

OTC was founded in 1925 in Owatonna, Minnesota as the Owatonna Tool Company.

What started as a small specialty tool manufacturer has grown into a global provider of specialty tools to nearly every technician, mechanic, independent repair shop, automotive dealership and tractor manufacturer.

OTC continues to operate its design, engineering, manufacturing and distribution facility in Owatonna, Minnesota. The current plant opened in the late 1950s, employing hundreds of tool specialists who forge, heat treat, coat and assemble the OTC tools you trust.

Since its founding, OTC has always stood for quality and ingenuity, creating reliable solutions that make repairing vehicles and equipment easier.

The OTC tool you purchased today has been crafted to exacting specifications to provide you with the tool you need, when you need it, for life. All OTC tools are covered by a lifetime warranty, ensuring years of worry-free use. OTC tools are key to getting the job done.

Thank you for supporting OTC. Your purchase drives the research, innovation, engineering and development of new tools and equipment.

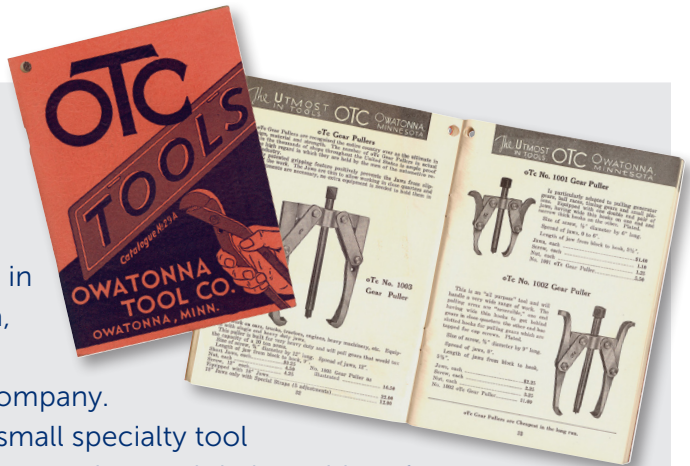

Safety Information



All Automotive Stands

- Study, understand, and follow all instructions before operating these devices.
- Wear ANSI Z87.1 and OSHA approved eye protection.
- Do not exceed rated capacity.
- Use only on a hard, level surface capable of supporting the load.
- Center load on saddle.
- Locate saddles at vehicle manufacturer's designated support points.
- No alterations shall be made to these products.
- Failure to heed these markings may result in personal injury/property damage.



Jack Stands

- Use only as an identical pair.
- Maximum load capacity per identical pair shall not exceed the rated capacity of the individual stand.
- Use stands to support one end of a vehicle only. These stands are not to be used to simultaneously support both ends of a vehicle.

All High Reach Stands

- Only attachments, restraints, or adapters supplied by the manufacturer shall be used.
- Do not enter the vehicle or start the engine while the vehicle is supported on stands.

Supplementary Support Stands

- Do not use these stands to support a vehicle.
- Use stands in pairs to stabilize the vehicle before starting repairs.

(Continued on next page.)



Safety Information *(continued)*

- Use a minimum of four stands to support and stabilize a vehicle, and a minimum of two additional stands for each axle assembly, before starting repairs.
- The vehicle shall be raised only once to place vehicle support stands under the entire vehicle.
- Ensure stands are stable and vehicle is balanced before lowering the vehicle onto stands.
- Carefully lower the vehicle onto all stands simultaneously.
- Do not apply horizontal forces or large torque loads to vehicle while the vehicle is supported on stands.

Under Hoist Auxiliary Stands

- These stands are intended to provide partial support of vehicle components during removal and installation.
- Adequately support the vehicle before starting repairs.
- Do not use to support or stabilize vehicle.

Shop Equipment Recommendations

As with any tool or piece of equipment, it is highly recommended to follow all applicable safety guidelines pertaining to its use. Appropriate Personal Protective Equipment as outlined by OSHA and ANSI standards, include (but are not limited to) safety glasses or face shields, protective gloves, hearing protection and reinforced (or safety toe) footwear. While using tools and equipment, ensure that you are clear of any moving parts or potential pinch points. To ensure the continued safe operation of tools and equipment, always follow manufacturer's recommended cleaning and lubrication schedules to prevent foreign material build up.

Inspection Instructions

Upon delivery, inspect carton for unnecessary damage. Where appropriate, address carton damage with carrier.

Remove jack stand from carton and assemble following the instructions in this manual. Inspect jack stand for the following:

- Inspect paint for chipping, runs, misses or overspray.
- Inspect weldments for breaks or spatter.

If your inspection reveals any issue with the jack stand's appearance or performance, please contact the

to report an issue and file a warranty claim.

If possible, retain the original carton for return shipping. A replacement will be sent and a call tag will be issued to pick up the jack in question.

**The warnings and instructions discussed
in this manual cannot cover every situation,
Always work with a focus on safety.**

Assembly Instructions

Ratchet and Pawl Style Stand

1. Install the ratchet bar into the frame with the ratchet portion of the bar aligned with the locking pawl (stopper).
2. Move the ratchet bar to its lowest position by raising the locking handle (which releases the stopper) and guiding the bar downward.
3. Use a hammer and punch to tap the tab into position (almost touching the ratchet bar). When the ratchet bar is extended, the tab will catch on a lip, preventing over-extension of the ratchet bar.

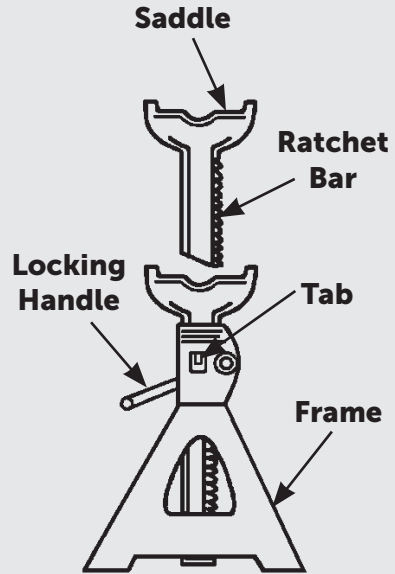

Figure 1

Pin Style Stand

1. Install the support tube into the base, aligning the hole through the base with the holes at the bottom of the tube.
2. Install the base bolt through the base and support tube, thread the nut onto the end of the bolt.

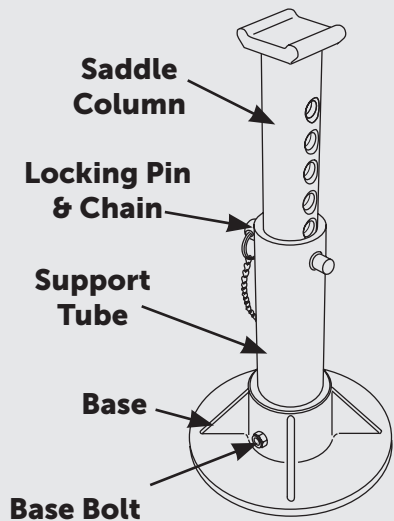
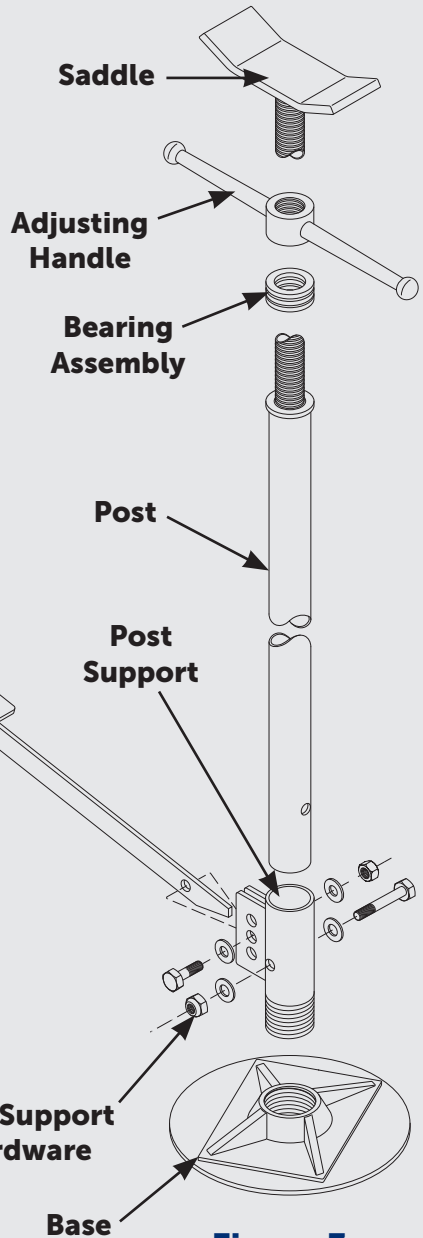

Figure 2

JACK STAND INSTRUCTIONS

High Reach Under Hoist Auxiliary Stand

1. Attach post support to base.
2. Insert post into post support, aligning holes. Secure with support tube hardware (clevis pin, [2] washers, and cotter pin.)
3. Screw adjusting handle onto threaded rod until tight against saddle pad.
4. Place bearing assembly onto threaded rod and set rod into post.



Foot Pedal
(See instructions below.)

Under Hoist Auxiliary Stand with Pedal

1. Complete the above steps 1-4 and then, attach pedal to post support, and secure with clevis pin, (2) washers, and cotter pin.

Post Support Hardware

Base

Figure 3

Assembly Instructions *(continued)*

High Reach Supplementary Support Stands

Tube Assembly

1. Use bolts to attach saddle to saddle base.
2. Slide screw rod into outer tube. Install bearing on outer tube.
3. Install handle and saddle base onto screw rod and secure with a bolt.

Stand Assembly

1. Loosely attach braces to legs using bolts, washers, and nuts provided.
2. Loosely attach tube brackets to legs using bolts, washers, and nuts provided.
3. Loosely attach tube plate to tube brackets using bolts, washers, and nuts provided.
4. Slide outer tube assembly through bushing base and tube plate. Use detent pin and chain assembly to lock tube in any position.
5. Securely tighten bolts and nuts.

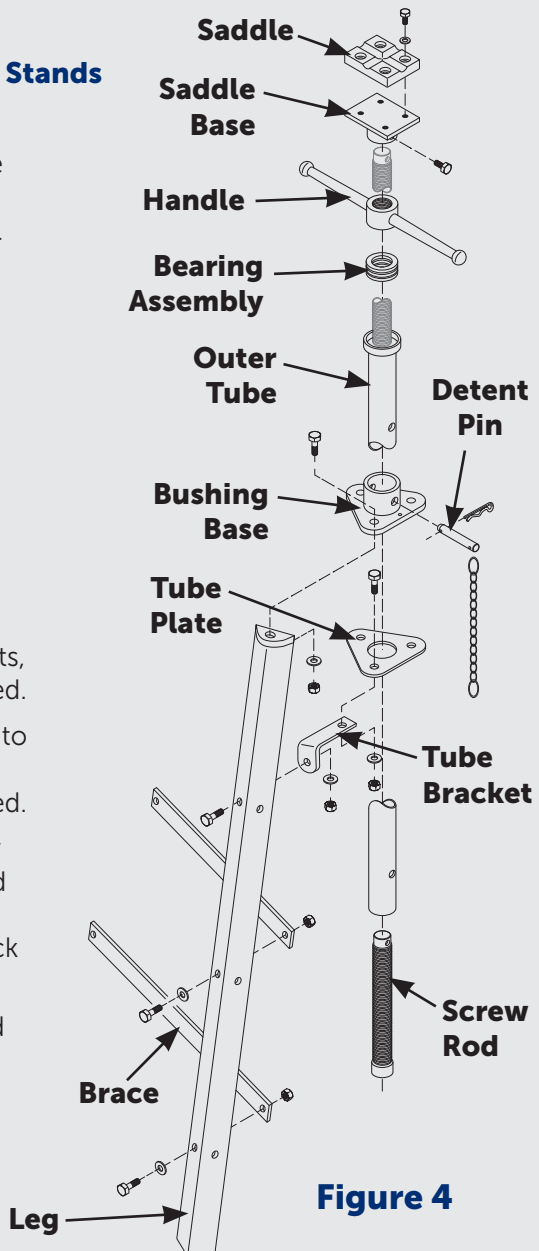
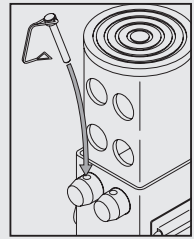

Figure 4

Operating Instructions OTC Jack Stands

1. Before every use – INSPECT the jack stand for performance issues. Do not use the jack if any quality issue is discovered.
2. Plan the location of the jack stands in pairs on a smooth, hard, level surface to ensure a balanced load.
3. Position each jack stand so the weight will be exerted on the center of the saddle.
4. Extend the jack up to the load. Insert pins or lock handles in place, depending on the model of jack stand.

⚠️ WARNING: To prevent personal injury and/or equipment damage, ensure all pins are completely inserted through support tubes AND saddle columns and locked in place. Ensure lock handles are completely engaged in ratchet grooves.



5. Slowly and carefully lower the load onto the jack stands.
6. When service work is complete, raise vehicle off of jack stands with the same equipment that raised the vehicle initially, and remove stands from under the vehicle.
7. Keep clear of load while lifting and lowering the vehicle.
8. Carefully and slowly lower vehicle onto the ground.

High Reach Auxiliary Stands (See Fig. 3)

Raise the Load

1. Turn adjusting handle clockwise until saddle meets load. Continue turning handle or use pedal to raise load to required height.

Lower the Load

1. Turn adjusting handle counterclockwise.

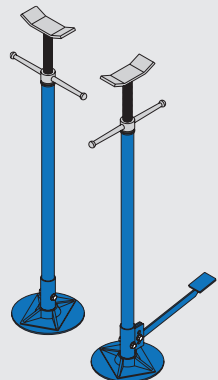



Operating Instructions *(continued)*

High Reach Supplementary Support Stands (See Fig. 4)

Raise the Load

⚠ WARNING: To prevent personal injury and/or property damage, do not attempt to remove the detent pin with a load on the stand.

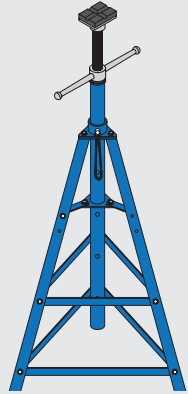

1. Major adjustments in the height of the stand must be made before putting a load on the stand. For a major adjustment, remove the detent pin and raise the outer tube to desired height. Replace detent pin.
2. Once a load is on the stand, minor adjustments can be made by turning the adjusting handle clockwise to a desired height.

Lower the Load

1. Turn adjusting handle counterclockwise.
2. For a major adjustments, remove the detent pin and lower the outer tube to desired height. Replace detent pin.