

# Installation Manual

**LOADLEASH®**

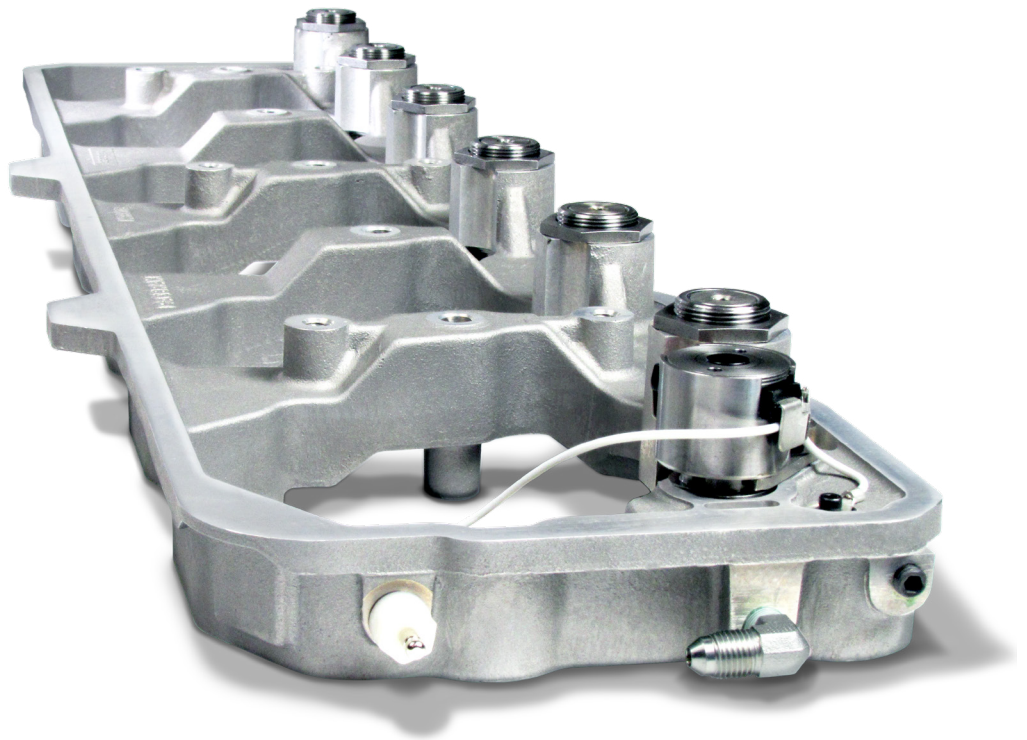

## INTEGRATED ENGINE BRAKE

# P67

### **P55003 P67 LoadLeash Kit:**

**2007½-2013 Dodge Pickup Trucks & Sterling  
Chassis Cab Trucks w/ Cummins  
6.7L Diesel Engines**

### **P55004 P67 LoadLeash Kit:**

**2014+ Dodge Pickup Trucks &  
Chassis Cab Trucks w/ Cummins  
6.7L Diesel Engines**

**/// PAC BRAKE®**

## Thank you for purchasing a Pacbrake P67 LoadLeash integrated engine brake kit for Cummins 6.7L diesel engines.

**BEFORE STARTING THE INSTALLATION**, please read the entire installation manual carefully. Check that your Pacbrake LoadLeash kit is correct for the application and contains all the necessary parts.

**NOTE:** Due to the high complexity of the emission system strategy and the fact that the LoadLeash controller monitors the injector signals, you may experience a very rare event of unexpected engine brake interruption.



**IMPORTANT NOTE TO ALL INSTALLERS:** If this LoadLeash kit is to be installed with ARP custom age 625 studs (Part # 247-4204) you must purchase our PAC/ARP stud kit (Part # P55127, shown). This LoadLeash kit may be installed with ARP studs (part # 247-4202) with no other required parts.

**IF THIS VEHICLE IS EQUIPPED WITH ANY ARP HEAD STUDS, PLEASE READ "IMPORTANT NOTE" AT STEP #10 OF THIS MANUAL.**

## REQUIRED TOOLS LIST

- Cummins #7471-B Flywheel Barring Tool
- ½" Drive Ratchet
- ¾" Drive Ratchet
- 8mm, 10mm, 13mm, 19mm, ½", 9/16" Standard Depth & Deep Depth Sockets
- Phillips #2 Screw Driver
- 7/16", ½", 9/16", 5/8" & 19mm Combination Wrenches
- Diagonal Cutters
- Pliers
- Wire Crimpers & Strippers
- LoadLeash's SMBC (Standard Modular Braking Component) Jam Nut Wrench - INCLUDED IN KIT (P55109)
- ½" Extension 3" Long
- ¾" Extension 3" Long & 6" Long
- ¼" Drive Ratchet
- Flat Blade Screw Driver ⅛" x 2 & ¼" x 4
- Feeler Gages
- 3/16" & 6mm Allen Wrench (or 6mm Allen Driver)
- Torque Wrenches Accurate @ 11 in-lbs (1.25 N•m), @ 89 in-lbs (10 N•m), @ 18 ft-lbs (24 N•m) and @ 77 ft-lbs (105 N•m)
- Thread Sealant
- Dremel Tool
- Pneumatic Pencil Grinder

### LOADLEASH KIT COMPONENTS

Please ensure the LoadLeash Kit contains all the parts listed below before starting the installation.

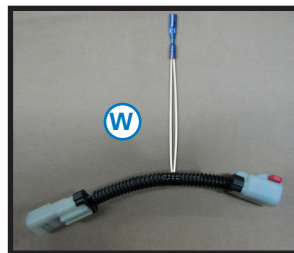
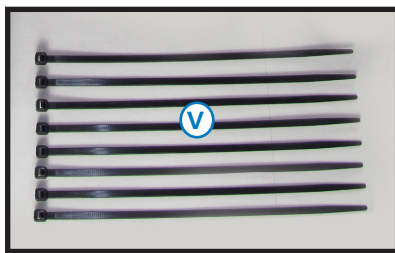
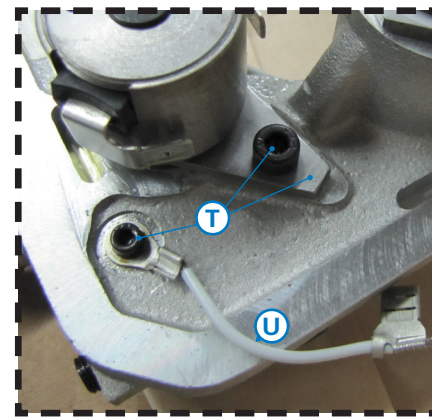
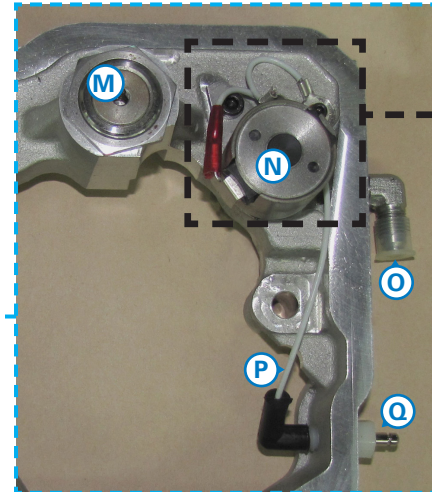
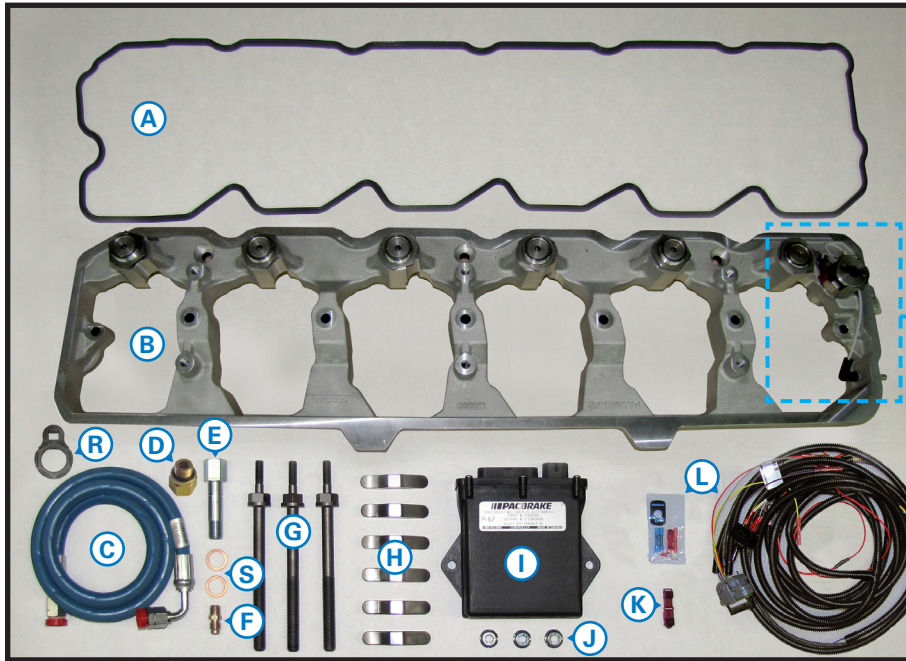

PART #	COMPONENT
A	<b>P55111</b> Gasket, Lower
B	<b>P55102</b> Assembly Housing
C	<b>P55101</b> Assembly Hose
D	<b>P55116</b> ORB Fitting (P55004 kits only)
E	<b>M3466</b> Bolt, Banjo (P55003 kits only)
F	<b>C3467</b> Fitting #4 JIC-1/8" NPT
G	<b>M5510</b> Double Ended Bolt (x3)
H	<b>M5512</b> Crosshead (x6)
I	<b>C20284</b> Controller
J	<b>M5514</b> Nut, Hex Flange M8 (x3)
K	<b>M8194</b> Scotchlock, T-Tap, 20 Gauge
L	<b>C20283</b> Harness

PART #	COMPONENT
M	<b>P55100</b> SMBC (x6)
N	<b>M4400</b> Solenoid, with Seals
O	<b>C3468</b> Fitting, 90° #4 JIC-1/8" NPT
P	<b>P55119</b> Harness, Solenoid
Q	<b>P34654 &amp; P34655</b> Terminal, Thru Head & O-Ring
R	<b>P55109</b> SMBC Jam Nut Wrench
S	<b>C20510</b> Washer, Copper (P55003 kits only)
T	<b>P55122</b> Solenoid Holddown Kit
U	<b>P55102</b> Solenoid Ground Harness
V	<b>C11618</b> Tie Strap (x8)
W	<b>C20533</b> Jumper Harness
X	<b>P55127</b> PAC/ARP Stud Kit (Optional)

## GETTING STARTED

**IMPORTANT:** Ensure the vehicle has the Variable Geometry Turbocharger (VGT) enabled for exhaust braking. This is mandatory for the P67 LoadLeash to function correctly. The vehicle must be road tested to ensure the VGT is functioning correctly BEFORE the P67 kit is installed. If the VGT is NOT performing correctly, it MUST be repaired BEFORE the P67 kit is installed for optimum braking performance.

### 1 ELECTRICAL INSTALLATION

#### Consult with the customer for their choice of LoadLeash control switch location.

A recommended location is the area behind the turn signal indicator, just above the lower dash panel.

The lower dash panel needs to be removed to gain access. The dash switch requires a ½" hole be drilled to accommodate the dash switch.

Install the LoadLeash switch and switch plate, as shown in *Photo 1*.



1

### 2 Remove the driver side knee panel to gain access to the base of the steering column.

At the base of the steering column, locate the PINK with WHITE tracer wire. This is a 12 VDC ignition power supply.

Install the RED t-tap connector onto this wire and connect to the RED fused wire of the LoadLeash harness.

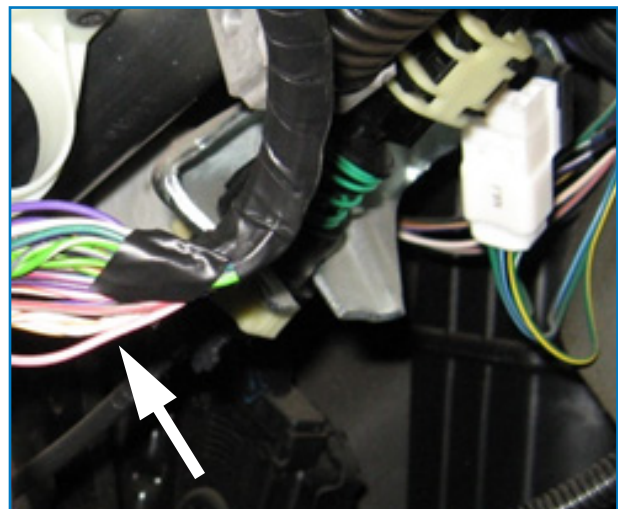

2

- 3** Disconnect the negative and positive battery terminals from BOTH batteries.
- Route the switch harness through the fire wall, to the driver side of the engine compartment.
- Mount the controller to the power steering lines with the supplied tie straps.

- 4** Connect the 4 wires from the LoadLeash switch harness to the coinciding wires of the harness connected to the LoadLeash controller.
- Heat shrinkable butt connectors are provided.
- Once crimped, heat the connector to provide a water tight seal.
- Route the harness's WHITE wire with 90° BLACK bullet connector to the rear of the engine.
- Secure using the supplied tie straps.
- This wire will be connected in *Step 17*.

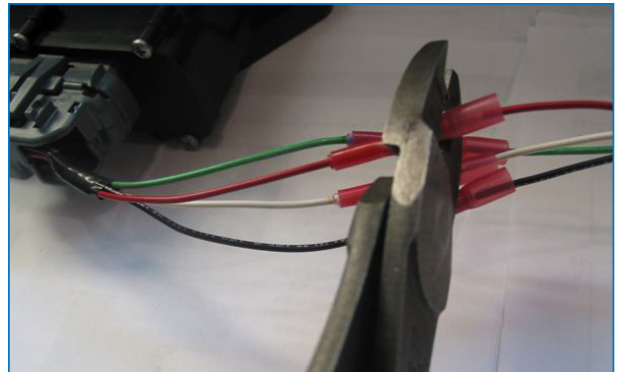

4

- 5** Route the BLACK wire of the harness to the negative terminal of the driver's side battery.
- Crimp on the RED ring terminal and connect to the negative terminal stud.
- 6** Route the twisted & jacketed, YELLOW and GREEN wires of the LoadLeash harness to the **forward** injector harness plug and secure with the supplied tie straps.
- Cut to length and strip off 3" of the jacket.

**7** Using the supplied heat shrinkable BLUE butt connectors, splice the GREEN wire of the LoadLeash harness into the wire located in port "A" of the factory injector harness. Reference *Diagram 7A* for port locations.

Splice the YELLOW wire of the LoadLeash harness into the wire located in Port "B" of the factory injector harness.

Using a heat gun, shrink and secure all the butt connectors, *Photo 7B*.

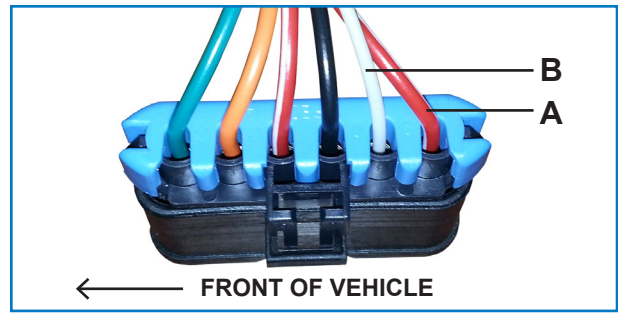

7A

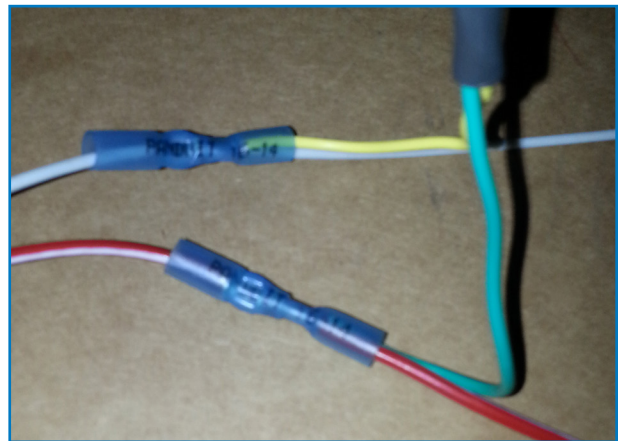

7B

**8** Route the BLUE wire of the LoadLeash harness to the Crankshaft Speed Sensor, located below the harmonic balancer on the driver's side of the engine.

Unlock and unplug the factory harness connector.

Obtain the supplied crankshaft sensor jumper harness, connect the female connector to the crankshaft sensor and lock. See *Photo 8A* of lock/unlocked positions.

Connect the factory female connector to the male connector of the jumper harness, and lock.

Secure the BLUE wire with the provided tie straps away from any moving parts or high heat sources,

Route this wire to heat shrinkable butt connector of the jumper harness, cut this wire to length, connect to the WHITE wire of the jumper harness.

Once crimped, heat the connector to provide a water tight seal.

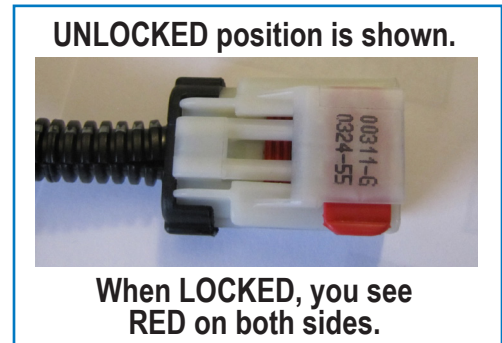

8A

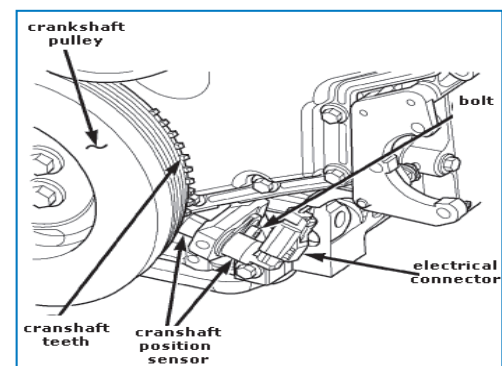

8B

- 9** Secure all wires away from moving parts and heat sources using the supplied tie straps.

**NOTE:** Thoroughly clean the top end of the engine before removing the valve cover to prevent dirt from entering the engine when the valve cover is removed. Some engines may need to be cleaned again once the cosmetic covers are removed to ensure no dirt or dust enters the engine.

Remove the engine's valve cover and the valve cover spacer (including the injector electrical harness) to gain access to the valve train.

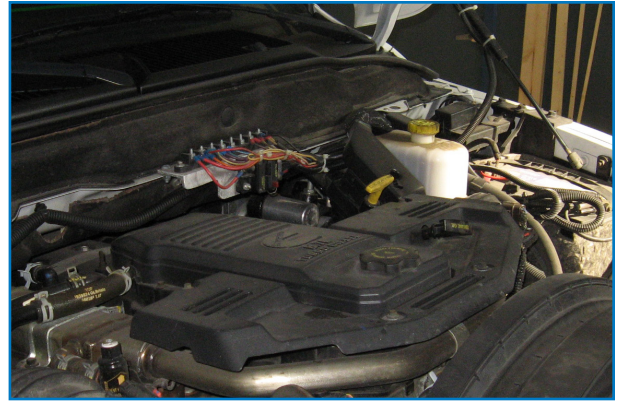

9

## 10 HEAD BOLT REPLACEMENT

Remove the cover plate on the front passenger side of the flywheel housing to gain access for the barring tool.

Using a flywheel barring tool (Cummins #7471-B), rotate the crankshaft to align the TDC mark on the balancer to 12 o'clock. The mark must be aligned at 12 o'clock.

### THE ENGINE MUST BE AT TDC #1.

This mark can be either TDC #1 or TDC #6.

Check if the rocker arms on the #1 cylinder are loose. If BOTH the intake and exhaust rockers on #1 cylinder are not loose, then the engine is positioned at TDC #6.

It is mandatory to rotate the engines crankshaft another 360° to attain TDC #1.

Once TDC #1 is obtained, remove the barring tool.



10A

### IMPORTANT:

If this vehicle is equipped with ARP Head Studs, you must ensure that the top of EVERY ARP stud DOES NOT protrude more than a MAXIMUM of 18.25mm or 0.718" from the cylinder head face (under the washer - shown at the white arrow head) to the top of the ARP head stud (black arrow head), see Photos 10B & 10C for details.

Otherwise, interference with the LoadLeash will cause improper installation and engine failure!

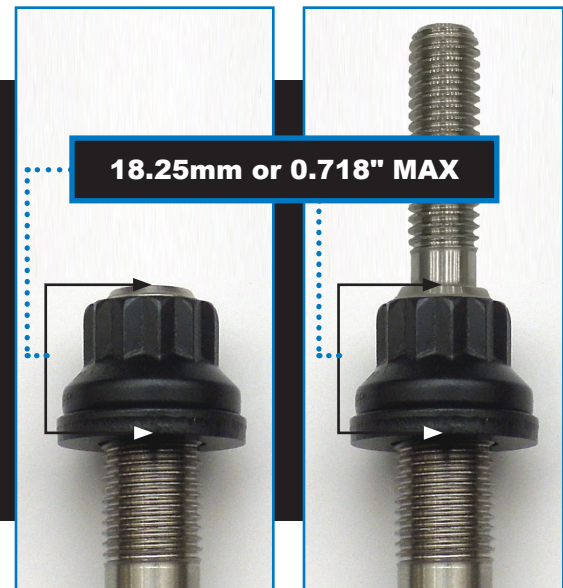

10B

10C

## 10

CONTINUED

During the machining process of the cylinder block, not all cylinder head hold-down bolt threads will be tapped to the same depth. This will cause interference between aftermarket head studs and the LoadLeash housing.

When installing aftermarket head studs, it is suggested that all the threads be bottom-tapped.

If the vehicle has already had aftermarket head studs installed (not bottom tapped) and interference is found, then it is necessary to rectify the interference by one of three ways:

- 1) Bottom-tapping the block with the head removed
- 2) Bottom-tapping the block, with the head installed, by using tap extensions
- 3) Removing the affected head stud, and mechanically shortening the length

## 11

It is mandatory to replace 3 of the existing 26 cylinder head bolts/aftermarket head studs with the LoadLeash double ended bolts provided or PAC/ARP Stud Kit, P55127

**The bolts MUST be replaced one at a time.**

Bolt installation locations are shown in *Drawing 11A*.

Lightly lubricate a LoadLeash head bolt on the lower threads and under the hex head with engine oil and install.

**Tighten each LoadLeash double ended bolt (included in this kit) as follows:**

- Torque bolt to 52 ft-lbs (70 N•m)
- Back off 360°
- Torque the bolt to 77 ft-lbs (105 N•m)
- Tighten an additional ¼ turn (90°)

Repeat on the remaining 2 head bolts (one at a time) until all 3 LoadLeash head bolts are installed.

**For (optional) PAC/ARP Studs (Kit # P55127):**

- Torque nuts in three equal steps to 150 ft-lbs (203 N•m) with ARP Ultra-Torque Fasteners Assembly Lubricant.

### VERY IMPORTANT:

**Under no circumstances should the engine crankshaft be rotated with a head bolt removed.**

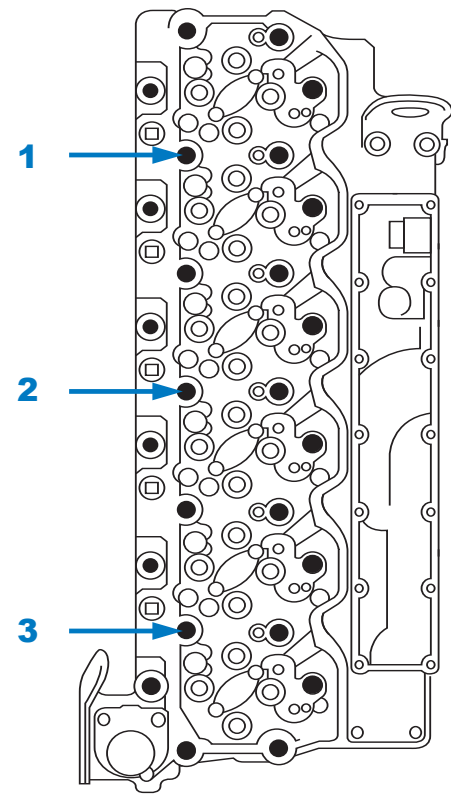

11A





## 12 CROSSHEAD REPLACEMENT

Locate the 6 replacement crossheads provided in the kit. These crossheads replace the factory exhaust crossheads.

The exhaust rocker arms are the longer of the two rocker arms. Use caution with the rocker arm as the foot that contacts the crosshead may separate due to a cracked retainer - this is a normal occurrence.

Starting with the #1 cylinder, rotate the exhaust valve adjusting screw counter-clockwise until the pushrod can be removed from under the adjusting screw.

Once the pushrod is removed from the rocker arm, the rocker arm can be rotated to remove the factory Cummins crosshead from the valve stems. Discard the Cummins crosshead.

Place the LoadLeash crosshead on the valve stems.

The LoadLeash crosshead must be installed with the domed side (slave piston contact surface) towards the exhaust manifold, as shown in the *Photo 12*.

Once the LoadLeash crosshead is installed, align the pushrod into the exhaust valve adjusting screw.

Rotate #1 cylinder exhaust valve adjusting screw clockwise back to its original position.

Repeat on cylinder #3 and cylinder #5 exhaust valves.

**Ensure the bottom end of the push tube remains seated into the tappet socket before proceeding.**



12

### 13 VALVE SETTING

Adjust the intake and exhaust valve lash for TDC #1 as instructed below. To obtain accurate measurements and adjustments, the engine coolant temperature must be less than 140°F (60°C).

Ensure you're still on TDC#1 before performing a valve adjustment. From this position, the exhaust valves **MUST** be set on cylinders 1-3-5 and the intake valves **MUST** be set on cylinders 1-2-4.

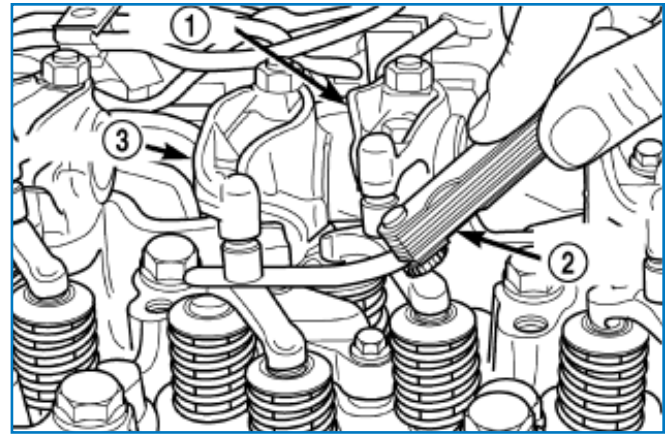

Refer to the set clearances in the *Table 13*. Measure the valve lash by inserting a feeler gage between the rocker arm foot and the crosshead.

Once the valve is adjusted, torque the adjusting screw lock-nut to 18 ft-lbs (24 N•m). Mark the lock-nut with a metal marker to identify that it has been re-adjusted.

	INTAKE	EXHAUST
<b>TDC #1</b>	1 - 2 - 4	1 - 3 - 5
<b>TDC #6</b>	3 - 5 - 6	2 - 4 - 6

VALVE LASH LIMIT CHART		
	INTAKE	EXHAUST
	0.152 mm ( 0.006 in.) MIN.	0.533 mm (0.021 in.) MIN.
	0.381 mm (0.015 in.) MAX.	0.863 mm (0.034 in.) MAX.
<i>NOTE: If measured valve lash falls within these specifications, no adjustment/reset is necessary. Engine operation within these ranges has no adverse affect on performance, emissions, fuel economy or level of engine noise.</i>		
SUGGESTED SETTING	INTAKE	EXHAUST
	0.254 mm ( 0.010 in.)	0.660 mm ( 0.026 in.)

13

Once the exhaust valves on cylinders 1-3-5 and the intake valves on cylinders 1-2-4 have been adjusted, proceed to *Step 14*.

### 14 Using the engine barring tool, rotate the engine to TDC #6. Repeat Step 12 (Crosshead Replacement, Page 8) on exhaust valves #2, #4 and #6.

Once the crosshead replacement is complete, the exhaust valves **MUST** be adjusted on cylinders #2, #4 and #6 and the intake valves **MUST** be adjusted on cylinders #3, #5 and #6, as per the valve lash chart in *Step 13*.

Re-adjust if necessary using the chart in *Step 13*.

Once complete, check all the exhaust valve adjusting screw lock-nuts to ensure all 6 have been torqued after the LoadLeash crossheads have been installed.



14

## 15 GASKET INSTALLATION

Install the supplied lower gasket into the groove on the underside of the LoadLeash valve cover spacer. Ensure the gasket bead is centered, not twisted in the groove and that there are no cuts, nicks or tears in the gasket that could cause an oil leak.

**CAUTION:** When installing the LoadLeash rocker housing spacer onto the cylinder head, do not slide the housing from side to side as the gasket can fall out or be damaged.

**USE EXTREME CAUTION NOT TO DRAG THE SPACER ACROSS THE ROCKER ARMS DURING THE INSTALLATION.**

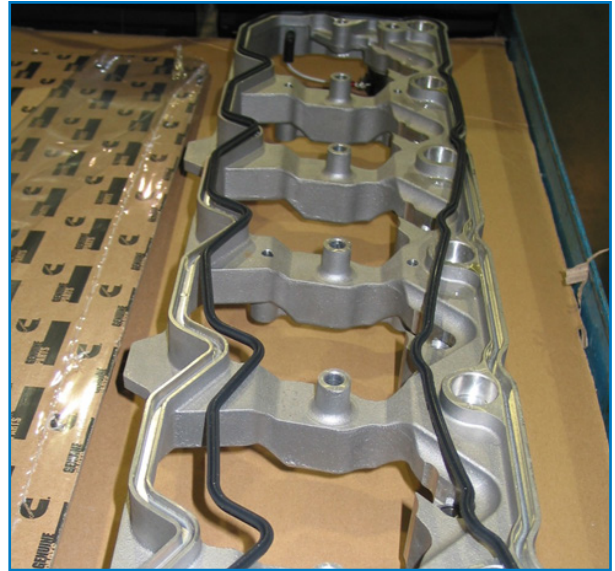

15

## 16 OIL PRESSURE SUPPLY TO LOADLEASH SPACER

### 16A FOR 2007½ - 2013 MODEL YEAR TRUCKS ONLY: (WITH OIL PRESSURE SENSOR)

Locate the oil pressure sensor on the driver's side of the engine block.

**Note the existing orientation of the oil pressure sensor before removal. It will either be at 11 o'clock or 2 o'clock depending on the model year.**

Remove the banjo bolt and two copper washers (one on each side of the sending unit fitting).

Install the LoadLeash banjo bolt and the two replacement copper washers provided. Ensure the correct orientation of the oil pressure sensor, then torque the banjo bolt to 18 ft-lbs (24 N•m).

Install the #4 JIC to 1/8" NPT fitting provided into the end of the banjo bolt using a good quality thread sealant.



2007½ - 2013 TRUCKS

16A

### 16B FOR 2014+ MODEL YEAR TRUCKS ONLY: (WITHOUT THE OIL PRESSURE SENSOR)

Locate the hex drive ORB plug on the driver's side of the engine block. Using a 6mm Allen key or driver, remove the plug and discard, as the plug will not be reused.

**NOTE:** You may need to gently tap the Allen key or driver so that it's fully seated in the plug - to ensure it doesn't get stripped upon removal.

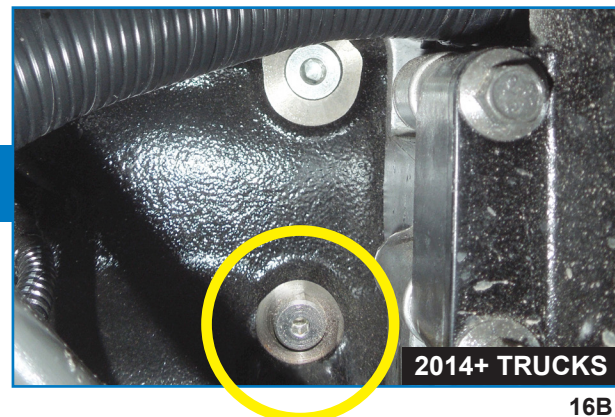

2014+ TRUCKS

16B

**16C FOR 2014+ MODEL YEAR TRUCKS ONLY:  
(WITHOUT THE OIL PRESSURE SENSOR)**

Install the #4 JIC to 1/8" NPT fitting, into the end of the M14 ORB to 1/8" NPT fitting, using a high quality thread sealant.

Install the fitting assembly into the M14 ORB port *shown circled in Photo 16C*.

Torque fitting assembly to 18 ft-lbs (24 N•m).

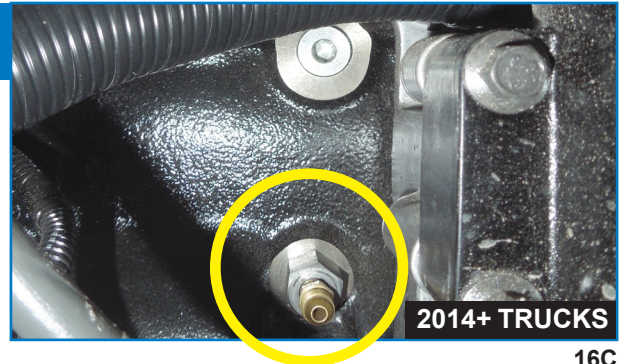

16C

**17** Before installing the LoadLeash spacer on the engine, clean the top of the cylinder head spacer gasket mating surface.

**IMPORTANT:** *The gasket must be completely dry and free of oil before installation.*

Remove the RED thread cover from the oil supply fitting at the rear of the spacer. Remove both RED port plugs from the oil supply hose.

Loosely connect the straight fitting end of the LoadLeash oil supply line to the fitting at the rear of the spacer.

**HELPFUL ADVICE...** Be sure to loosely connect the oil supply line to the spacer prior to installing the spacer, otherwise it will be nearly impossible to access it.

Position the LoadLeash spacer over the 3 LoadLeash head bolts.

Route the LoadLeash oil supply line to the LoadLeash banjo bolt (2007½ - 2013) or ORB fitting (2014+), connect and tighten. Ensure the oil supply hose is not contacting any moving parts.

Lift the LoadLeash spacer off the head bolts enough to access the oil supply line at the rear of the LoadLeash spacer & tighten the line to the fitting, as shown in *Photo 17*.

Connect the WHITE solenoid signal wire with the 90° bullet connector to the bullet terminal on the rear of the LoadLeash spacer.

Install the 3 flanged hex nuts provided on to the LoadLeash head bolts. or the 12 point nuts supplied in PAC/ARP Stud Kit, P55127, on to the stud.

Loosely install the factory spacer capscrews into the LoadLeash spacer.

Starting with the center fasteners, working your way out, torque the factory capscrews to 18 ft-lbs (24 N•m) and the LoadLeash flanged hex nuts to 27 ft-lbs (36 N•m) - Torquing is the same for PAC/ARP Studs (P55127).

Route and secure the oil supply line using the tie-straps provided, away from heat sources or moving parts.



17

## 18 ADJUSTING THE STANDARD MODULAR BRAKING COMPONENTS (SMBC)

The engine should be on TDC #6 as left on *Step 10*.

- The SMBC can be adjusted on cylinders #2, #4 and #6. Back off the lock nut enough to allow the SMBC to be adjusted.
- Using a 3/16" Allen wrench, rotate the SMBC until it contacts the LoadLeash crosshead, then turn the SMBC an additional one full turn clockwise to squeeze out the trapped oil, *Photo 18A*.
- Back off the SMBC to obtain clearance between the crosshead and the SMBC.
- Rotate the SMBC clockwise until it just contacts the LoadLeash crosshead, to establish zero lash between the crosshead and the SMBC.
- Back off the SMBC EXACTLY ½ of a turn. This is to achieve a clearance of 0.025". Using the LoadLeash lock nut wrench, torque the lock nut to 31 ft-lbs (42 N•m) while ensuring the SMBC does not rotate.



18A

### IMPORTANT NOTE:

The LoadLeash lock nut wrench must be kept 90° to the torque wrench.

If the wrench cannot be kept @ 90°, a Torque Wrench Extension calculation must be used to achieve the correct torque, reference *Diagram 18B* for formula information.

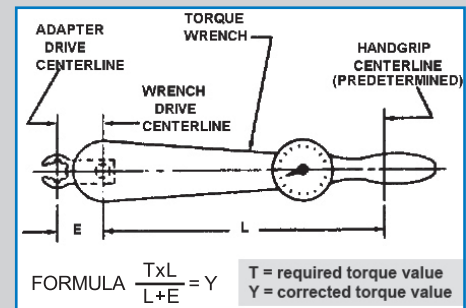

18B

- Repeat the adjustment on the remaining two cylinders.
- Using the barring tool, rotate the engine to TDC #1. REMOVE THE BARRING TOOL and reinstall the cover plate.
- The SMBC can now be adjusted on cylinders #1, #3 and #5 by repeating the steps above.
- **Ensure all SMBCs have been adjusted before proceeding.**

## 19 MODIFYING THE OEM SPACER GASKET / INJECTOR HARNESS

The stock OEM injector harness gasket will need to be modified to allow proper clearance around the LoadLeash engine brake casting, specifically the 6 SMBC cast towers.

You will need to mark the material that needs to be removed as shown in Figure 19A. You may need to cut the zip ties securing the wiring to gain better access to the area.

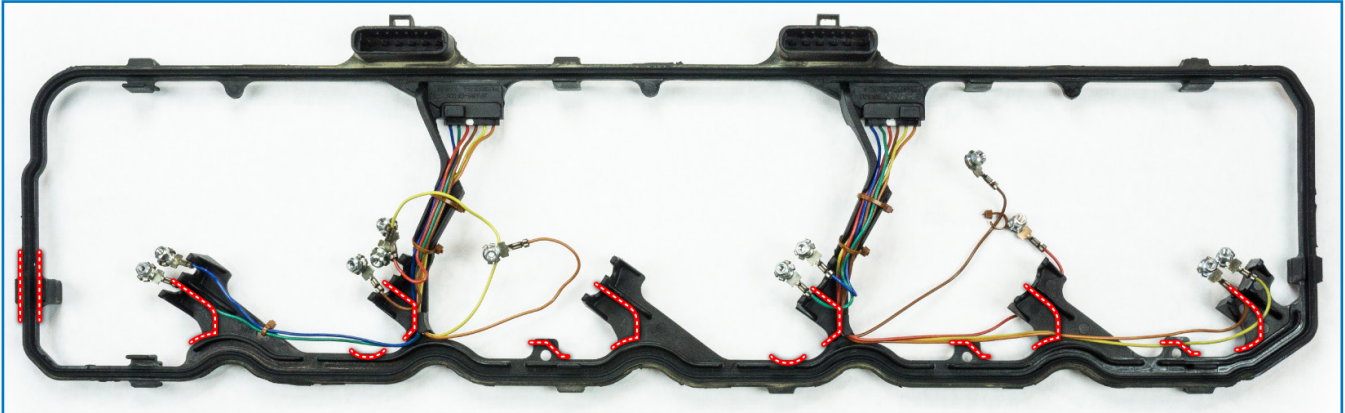

19A

Remove the marked off area with a dremel tool or a small pneumatic pencil grinder, see Figure 19B, 19C, & 19D for reference.



19B: Original Injector Harness Gasket

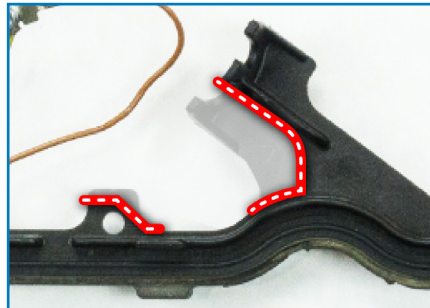

19C: Marked Area for Removal



19D: Finished Modified Gasket

Remove any additional materials needed until the gasket fits around all 6 SMBC cast towers and flat on the LoadLeash gasket surface, as shown in Figure 19E.

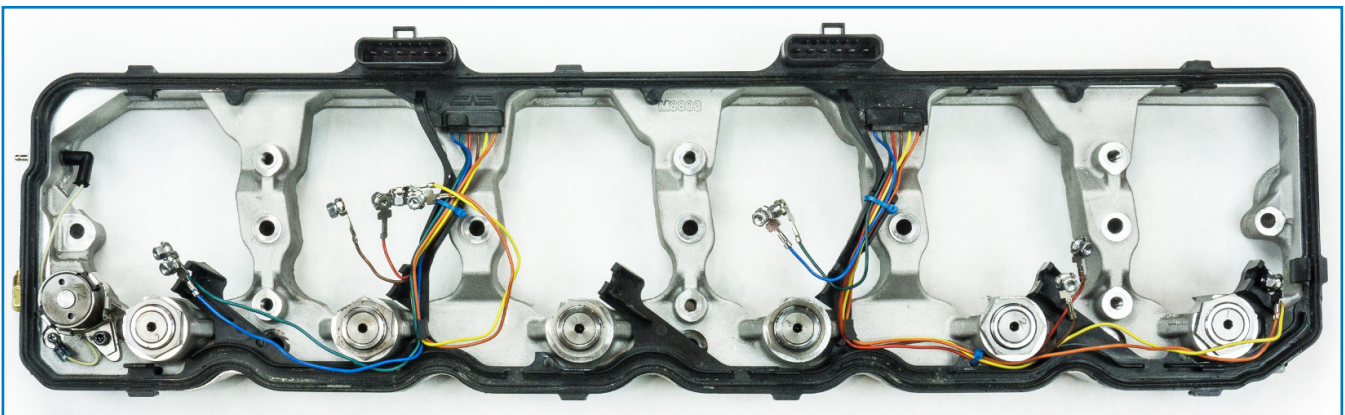

19E

## 20 INSTALLING THE MODIFIED OEM SPACER GASKET / INJECTOR HARNESS

Wipe any oil or residue from both sides of the valve cover gasket and inspect it for imperfections that could cause an oil leak.

Place the modified gasket/injector harness onto the LoadLeash spacer, ensuring the LoadLeash solenoid wire is not pinched between the gasket and the LoadLeash spacer.

Connect the injector harness to the solenoid terminals noting the correct wire orientation. Torque the injector harness nuts to 11 in-lbs (1.25 N•m).

**IMPORTANT! The injector wires, when tightened, must have a minimum of  $\frac{1}{8}$ " clearance between the terminal and the SMBC cast towers.**

Ensure the injector wires are not in a location where they could be pinched by the gasket, or near a rocker arm that could damage the wire.

**BE VERY CAREFUL NOT TO OVER TIGHTEN THE INJECTOR TERMINAL NUTS AS DAMAGE TO THE FUEL INJECTOR WILL OCCUR.**



20

## 21 Double-check the installation before re-installing the engine valve cover. Ensure that none of the injector wires are touching the SMBC cast towers.

Torque the valve cover capscrews, starting with the center working out, to 18 ft-lbs (24 N•m).

Wipe the oil from the crankcase cover vent gasket and inspect for imperfections that could cause an oil leak.

Replace if necessary.

Install the crankcase cover vent assembly and torque the capscrews to 89 in-lbs (10 N•m).

Connect the valve cover breather hoses and all the attaching parts removed to gain access to the valve train.

Connect the injector wiring harness to the connector on the valve cover gasket connector.



21

- 22** Install the supplied thermal label to the area shown *Photo 22A*. This label is found within the info pack included with this kit.

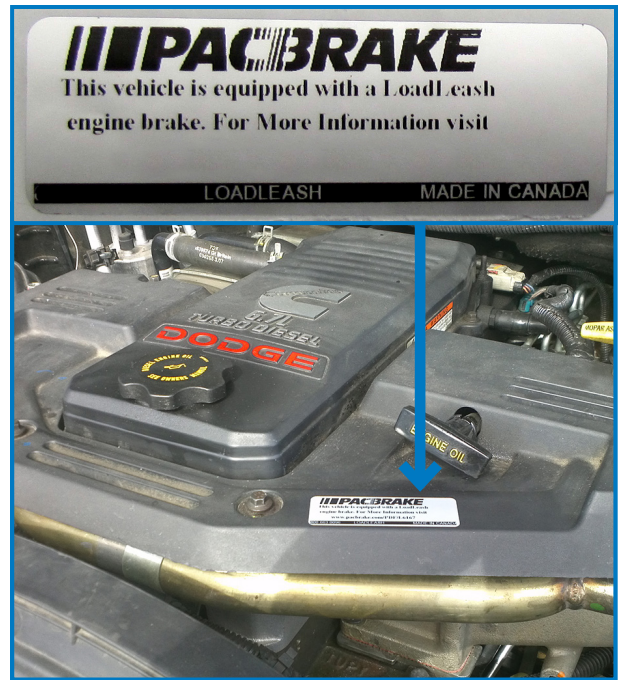

22A

- 23** Reconnect the vehicle batteries, start the engine, and check for oil leaks.





## DRIVER'S GUIDE: OPERATING YOUR LOADLEASH ENGINE BRAKE

A copy of this Driver's Guide can be found in the info pack included with this kit. Please keep it in the vehicle should you need it for reference.

### FUNCTIONALITY

Pacbrake's LoadLeash for Cummins 6.7L engines is a "weeper" or "bleeder" type engine brake which works in tandem with the vehicle's VGT exhaust braking feature.

It functions by holding the exhaust valves slightly off the seat during the complete engine cycle with the VGT providing exhaust backpressure and increased boost pressure.

#### Two braking strokes are achieved:

- 1 The first braking cycle is accomplished during the exhaust stroke when the piston is pushing the cylinder pressure past the open exhaust valve against the "closed" VGT.
- 2 The second braking cycle occurs during the compression stroke with the piston is pushing the cylinder pressure past the open exhaust valve against the "closed" VGT. The expansion stroke is eliminated by the open exhaust valve.

With work being done on both the compression stroke and exhaust stroke we are now doing retarding work on two engine cycles.

### OPERATION

For optimal braking, the following switches must be in the 'ON' position:

- **Tow/Haul** (to provide auto-downshifting in RAM / Sterling trucks with auto transmissions)
- **Exhaust Brake**
- **LoadLeash LED Switch**

***NOTE:*** It is advised to have engine up to operating temperature before using the LoadLeash as stalling of the engine may occur.

An alternative method is manually downshifting using the +/- switch on the column selector. This can be achieved with the Tow/Haul 'OFF' and the Exhaust Brake & LoadLeash Switches 'ON'.

### DRIVING IMPRESSIONS

Pacbrake's LoadLeash, used in tandem with the VGT exhaust braking feature, will result in a 40% increase in retarding HP when measured at the rear wheels (assuming 60 HP of drivetrain friction).

**LoadLeash + VGT = 360RHP | VGT Only = 210RHP**

"Seat of the pants" feel is noticeable, particularly above 2500 RPM with a heavy load. Manual downshifting may be required.

The LoadLeash is stronger at all RPMs and in most cases will control the vehicle/load in a chosen gear without the rapid downshifting and high engine RPM experienced with the exhaust brake use alone. The LoadLeash engine brake meets all municipal sound bylaws.

**ELECTRICAL SCHEMATIC: CUMMINS 6.7L DIESEL ENGINES**

