

OIL PAN ASSEMBLY

141281E



Description:	OIL PAN ASSEMBLY
SKU:	141281E
OEM:	3031959
Product Group:	ENGINE PARTS
Product Class:	OIL PANS & RELATED PARTS
UPC Code:	193807118709
Sell Pack:	1 EA
Weight:	45.25 LBS
Package Dimensions (LxWxH):	52 x 19 x 15 inches
Warranty:	1 Year



Details:
 This rear sump engine oil pan assembly is made of steel, finished in black, fits Cummins 855 / N14 engines and has a 44qt. oil capacity.

Substitute:

SKU	Sell Pack	Weight	Warranty	Description
141281	1	49.50 LBS	2 Years	OIL PAN ASSEMBLY

E-Catalog Pages:

Catalog Page	Description

Copyright © 2020 PAI Industries, Inc.
 All rights reserved. All content is property of PAI Industries, Inc. and may not be reproduced or redistributed in any form.

Any reference to OEM names or OEM product identification numbers/descriptions/model numbers is for identification only and does not indicate that it is an OEM part. PAI is not affiliated with Mack Truck, Inc.®, Volvo®, Fuller®, Cummins®, Eaton®, Rockwell®, Caterpillar®, Freightliner®, Hendrickson®, Kenworth®, Detroit Diesel®, International®, Peterbilt®, or Dana®. All Manufacturer's names, numbers, symbols and descriptions are used for reference only. It is not implied that any part listed is the product of these manufacturers.

OIL PAN ASSEMBLY

141281E

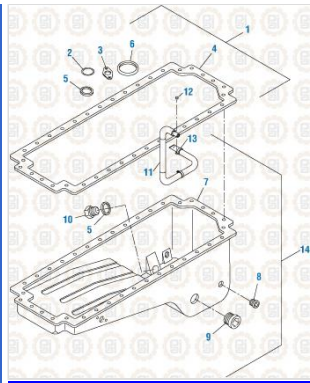

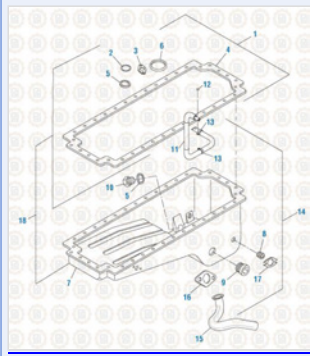

Cummins Engine 2017
Oil Pan Kit and Components - 855 Series



Cummins Engine 2017
Oil Pan and Components - N14 Series

Consists Of:

SKU	OEM	Image	Description	Quantity
131391	67946		WASHER	1
EPP-3575	49AX234Z		PLUG	2
EPP-3566	49AX226		PLUG	1
141328	3030257		OIL PAN	1

Copyright © 2020 PAI Industries, Inc.
All rights reserved. All content is property of PAI Industries, Inc. and may not be reproduced or redistributed in any form.

Any reference to OEM names or OEM product identification numbers/descriptions/model numbers is for identification only and does not indicate that it is an OEM part. PAI is not affiliated with Mack Truck, Inc.®, Volvo®, Fuller®, Cummins®, Eaton®, Rockwell®, Caterpillar®, Freightliner®, Hendrickson®, Kenworth®, Detroit Diesel®, International®, Peterbilt®, or Dana®. All Manufacturer's names, numbers, symbols and descriptions are used for reference only. It is not implied that any part listed is the product of these manufacturers.

OIL PAN ASSEMBLY

141281E

042010	3055069		DRAIN PLUG	1
141339	3071179		OIL PICKUP TUBE CLAMP	3
141329	3095051		OIL PICKUP TUBE	1
040100	3095723		NUT	3

Component Of:

SKU	Image	Description
141280E		OIL PAN KIT

Cross Reference:

Manufacturer	OEM Number
CUMMINS	3031959
CUMMINS	3070183
CUMMINS	3071260

Copyright © 2020 PAI Industries, Inc.

All rights reserved. All content is property of PAI Industries, Inc. and may not be reproduced or redistributed in any form.

Any reference to OEM names or OEM product identification numbers/descriptions/model numbers is for identification only and does not indicate that it is an OEM part. PAI is not affiliated with Mack Truck, Inc.®, Volvo®, Fuller®, Cummins®, Eaton®, Rockwell®, Caterpillar®, Freightliner®, Hendrickson®, Kenworth®, Detroit Diesel®, International®, Peterbilt®, or Dana®. All Manufacturer's names, numbers, symbols and descriptions are used for reference only. It is not implied that any part listed is the product of these manufacturers.