

SYNCHRONIZER DISC

GSD-2525



Description:	SYNCHRONIZER DISC
SKU:	GSD-2525
OEM:	495KB361
Product Group:	TRANSMISSION
Product Class:	SYNCHRONIZERS & RELATED PARTS
UPC Code:	193807192495
Sell Pack:	8 EA (Available to buy in increments of 8)
Weight:	1.79 LBS
Package Dimensions (LxWxH):	7 x 2 x 7 inches
Warranty:	2 Years



Details:
 Synchronizer Friction Disc
 8 required for application
 Mack T2080B / T2130 / T2180 Transmission application

E-Catalog Pages:

Catalog Page	Description
	<p>Drive Train 2016 Rear Case Components - T2080B</p>

Copyright © 2020 PAI Industries, Inc.
 All rights reserved. All content is property of PAI Industries, Inc. and may not be reproduced or redistributed in any form.

Any reference to OEM names or OEM product identification numbers/descriptions/model numbers is for identification only and does not indicate that it is an OEM part. PAI is not affiliated with Mack Truck, Inc.®, Volvo®, Fuller®, Cummins®, Eaton®, Rockwell®, Caterpillar®, Freightliner®, Hendrickson®, Kenworth®, Detroit Diesel®, International®, Peterbilt®, or Dana®. All Manufacturer's names, numbers, symbols and descriptions are used for reference only. It is not implied that any part listed is the product of these manufacturers.

SYNCHRONIZER DISC

GSD-2525

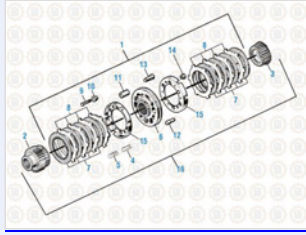

Drive Train 2016
Synchronizer Update - T2080B

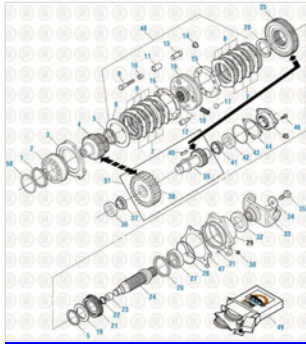

Drive Train 2016
Rear Case Components - Original Design Synchronizer - T2080, T2090 and T2100

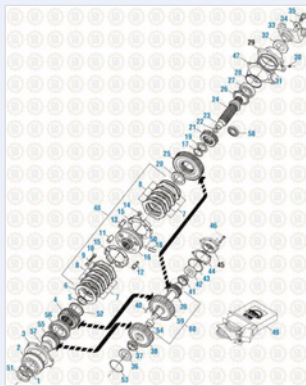

Drive Train 2016
Rear Case Components - T2130 and T2180

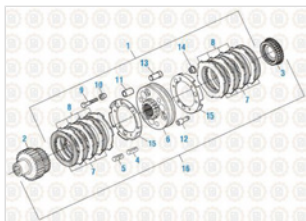

Drive Train 2016
Synchronizer Update - T2130 and T2180

Copyright © 2020 PAI Industries, Inc.
All rights reserved. All content is property of PAI Industries, Inc. and may not be reproduced or redistributed in any form.

Any reference to OEM names or OEM product identification numbers/descriptions/model numbers is for identification only and does not indicate that it is an OEM part. PAI is not affiliated with Mack Truck, Inc.®, Volvo®, Fuller®, Cummins®, Eaton®, Rockwell®, Caterpillar®, Freightliner®, Hendrickson®, Kenworth®, Detroit Diesel®, International®, Peterbilt®, or Dana®. All Manufacturer's names, numbers, symbols and descriptions are used for reference only. It is not implied that any part listed is the product of these manufacturers.

SYNCHRONIZER DISC

GSD-2525

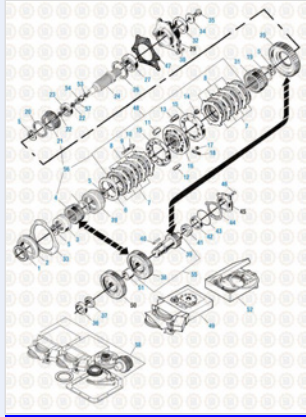

Drive Train 2016
Rear Case Components - T309L and T310

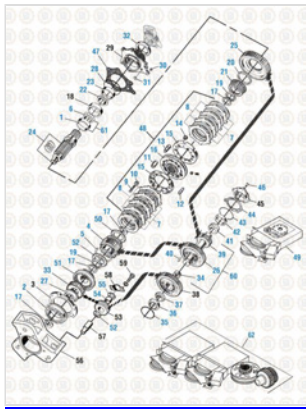

Drive Train 2016
Rear Case Components - T2110 B and D

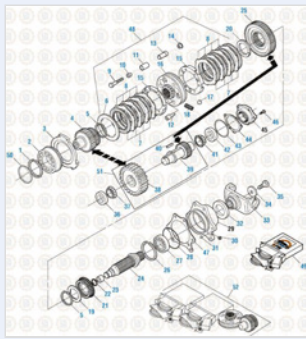

Drive Train 2016
Rear Case Components - Updated Design Synchronizer - T2080, T2090 and T2100

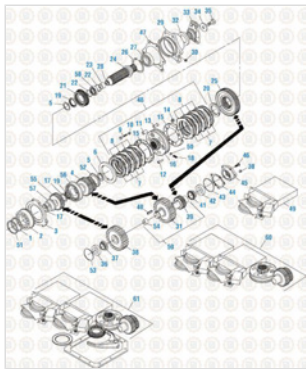

Drive Train 2016
Rear Case Components - T313L and T318L

Copyright © 2020 PAI Industries, Inc.
All rights reserved. All content is property of PAI Industries, Inc. and may not be reproduced or redistributed in any form.

Any reference to OEM names or OEM product identification numbers/descriptions/model numbers is for identification only and does not indicate that it is an OEM part. PAI is not affiliated with Mack Truck, Inc.®, Volvo®, Fuller®, Cummins®, Eaton®, Rockwell®, Caterpillar®, Freightliner®, Hendrickson®, Kenworth®, Detroit Diesel®, International®, Peterbilt®, or Dana®. All Manufacturer's names, numbers, symbols and descriptions are used for reference only. It is not implied that any part listed is the product of these manufacturers.

SYNCHRONIZER DISC

GSD-2525

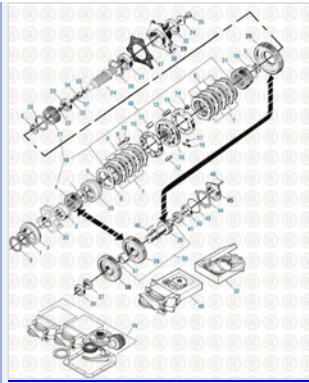

Drive Train 2016
Rear Case Components - T310M

Component Of:

SKU	Image	Description
EM25040		SYNCHRONIZER ASSEMBLY
GSA-2497		SYNCHRONIZER ASSEMBLY
GSA-2498		SYNCHRONIZER ASSEMBLY
GSA-2504		SYNCHRONIZER

Copyright © 2020 PAI Industries, Inc.
All rights reserved. All content is property of PAI Industries, Inc. and may not be reproduced or redistributed in any form.

Any reference to OEM names or OEM product identification numbers/descriptions/model numbers is for identification only and does not indicate that it is an OEM part. PAI is not affiliated with Mack Truck, Inc.®, Volvo®, Fuller®, Cummins®, Eaton®, Rockwell®, Caterpillar®, Freightliner®, Hendrickson®, Kenworth®, Detroit Diesel®, International®, Peterbilt®, or Dana®. All Manufacturer's names, numbers, symbols and descriptions are used for reference only. It is not implied that any part listed is the product of these manufacturers.

SYNCHRONIZER DISC

GSD-2525

[GSA-2505](#)



SYNCHRONIZER ASSEMBLY

[GSK-2533](#)

SYNCHRONIZER KIT

[GSA-2543](#)

SYNCHRONIZER KIT

Cross Reference:

Manufacturer	OEM Number
MACK	495KB361
MACK	495KB363
MACK	495KB363A
MACK	25086462
MACK	22067513

Copyright © 2020 PAI Industries, Inc.

All rights reserved. All content is property of PAI Industries, Inc, and may not be reproduced or redistributed in any form.

Any reference to OEM names or OEM product identification numbers/descriptions/model numbers is for identification only and does not indicate that it is an OEM part. PAI is not affiliated with Mack Truck, Inc.®, Volvo®, Fuller®, Cummins®, Eaton®, Rockwell®, Caterpillar®, Freightliner®, Hendrickson®, Kenworth®, Detroit Diesel®, International®, Peterbilt®, or Dana®. All Manufacturer's names, numbers, symbols and descriptions are used for reference only. It is not implied that any part listed is the product of these manufacturers.