

O-RING

321326

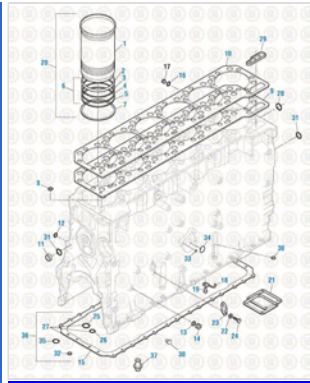

Caterpillar Engine 2019
Cylinder Block - 3406E / C15 / C16 / C18 Series

Component Of:



SKU	Image	Description
321380		O-RING KIT
321406		O-RING KIT
321407		O-RING KIT
331424		CENTRAL-LOWER GASKET KIT
331509		O-RING KIT
331511		FRONT GASKET KIT
331512		OIL COOLER GASKET KIT

Copyright © 2020 PAI Industries, Inc.
All rights reserved. All content is property of PAI Industries, Inc. and may not be reproduced or redistributed in any form.

Any reference to OEM names or OEM product identification numbers/descriptions/model numbers is for identification only and does not indicate that it is an OEM part. PAI is not affiliated with Mack Truck, Inc.®, Volvo®, Fuller®, Cummins®, Eaton®, Rockwell®, Caterpillar®, Freightliner®, Hendrickson®, Kenworth®, Detroit Diesel®, International®, Peterbilt®, or Dana®. All Manufacturer's names, numbers, symbols and descriptions are used for reference only. It is not implied that any part listed is the product of these manufacturers.

O-RING

321326

331546		OIL COOLER GASKET KIT
331562		LOWER GASKET SET
331623		OIL COOLER O-RING KIT
331627		CENTRAL/LOWER GASKET SET

Cross Reference:

Manufacturer	OEM Number
CATERPILLAR	153-0500
CATERPILLAR	1530500
CATERPILLAR	5M0281
CATERPILLAR	8J4351

Copyright © 2020 PAI Industries, Inc.

All rights reserved. All content is property of PAI Industries, Inc, and may not be reproduced or redistributed in any form.

Any reference to OEM names or OEM product identification numbers/descriptions/model numbers is for identification only and does not indicate that it is an OEM part. PAI is not affiliated with Mack Truck, Inc.®, Volvo®, Fuller®, Cummins®, Eaton®, Rockwell®, Caterpillar®, Freightliner®, Hendrickson®, Kenworth®, Detroit Diesel®, International®, Peterbilt®, or Dana®. All Manufacturer's names, numbers, symbols and descriptions are used for reference only. It is not implied that any part listed is the product of these manufacturers.