

# OIL PAN GASKET

# 331219



**Description:** OIL PAN GASKET  
**SKU:** 331219  
**OEM:** 1095308  
**Product Group:** ENGINE PARTS  
**Product Class:** ENGINE GASKETS, O-RINGS & GASKET SETS  
**UPC Code:** 193807124687  
**Sell Pack:** 1 EA  
**Weight:** 0.77 LBS  
**Warranty:** 2 Years



**Details:**

Oil Pan Gasket  
 Caterpillar 3176 /C10 /C12 application

**Substitute:**

SKU	Sell Pack	Weight	Warranty	Description
<a href="#">331219E</a>	1	0.75 LBS	1 Year	OIL PAN GASKET

**E-Catalog Pages:**

Catalog Page	Description

**Copyright © 2020 PAI Industries, Inc.**  
 All rights reserved. All content is property of PAI Industries, Inc, and may not be reproduced or redistributed in any form.  
 Any reference to OEM names or OEM product identification numbers/descriptions/model numbers is for identification only and does not indicate that it is an OEM part. PAI is not affiliated with Mack Truck, Inc.®, Volvo®, Fuller®, Cummins®, Eaton®, Rockwell®, Caterpillar®, Freightliner®, Hendrickson®, Kenworth®, Detroit Diesel®, International®, Peterbilt®, or Dana®. All Manufacturer's names, numbers, symbols and descriptions are used for reference only. It is not implied that any part listed is the product of these manufacturers.

# OIL PAN GASKET

# 331219

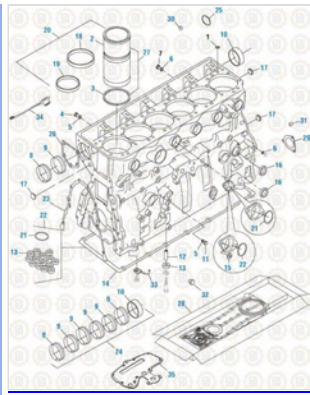

**Caterpillar Engine 2019**  
Cylinder Block - 3176 / C9 / C10 / C11 / C12 / C13 Series

**Component Of:**

SKU	Image	Description
<a href="#">331153</a>		OIL PAN GASKET KIT
<a href="#">331519</a>		LOWER GASKET SET
<a href="#">331562</a>		LOWER GASKET SET

**Cross Reference:**

Manufacturer	OEM Number
CATERPILLAR	109-5308
CATERPILLAR	1095308
CATERPILLAR	4P1497
CATERPILLAR	7E3370
CATERPILLAR	7E8648
CATERPILLAR	9Y4071

Copyright © 2020 PAI Industries, Inc.  
All rights reserved. All content is property of PAI Industries, Inc, and may not be reproduced or redistributed in any form.

Any reference to OEM names or OEM product identification numbers/descriptions/model numbers is for identification only and does not indicate that it is an OEM part. PAI is not affiliated with Mack Truck, Inc.®, Volvo®, Fuller®, Cummins®, Eaton®, Rockwell®, Caterpillar®, Freightliner®, Hendrickson®, Kenworth®, Detroit Diesel®, International®, Peterbilt®, or Dana®. All Manufacturer's names, numbers, symbols and descriptions are used for reference only. It is not implied that any part listed is the product of these manufacturers.