

VALVE COVER GASKET

331280



Description: VALVE COVER GASKET
SKU: 331280
OEM: 5P5678-3
Product Group: ENGINE PARTS
Product Class: ENGINE GASKETS, O-RINGS & GASKET SETS
UPC Code: 193807125288
Sell Pack: 1 EA
Weight: 0.48 LBS
Warranty: 2 Years



Details:

Valve Cover Gasket, 3 Meter roll
 Caterpillar 3100, 3176, 3400, 3406E, C7, C10, C11, C12, C13, C15, C16, C18 Application

E-Catalog Pages:

Catalog Page	Description
	<p>Caterpillar Engine 2019 Cylinder Head - 3400 Series</p>

Copyright © 2020 PAI Industries, Inc.
 All rights reserved. All content is property of PAI Industries, Inc, and may not be reproduced or redistributed in any form.

Any reference to OEM names or OEM product identification numbers/descriptions/model numbers is for identification only and does not indicate that it is an OEM part. PAI is not affiliated with Mack Truck, Inc.®, Volvo®, Fuller®, Cummins®, Eaton®, Rockwell®, Caterpillar®, Freightliner®, Hendrickson®, Kenworth®, Detroit Diesel®, International®, Peterbilt®, or Dana®. All Manufacturer's names, numbers, symbols and descriptions are used for reference only. It is not implied that any part listed is the product of these manufacturers.

VALVE COVER GASKET

331280

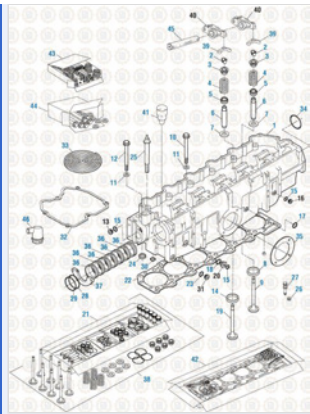

Caterpillar Engine 2019
Cylinder Head - 3406E / C15 / C16 / C18 Series

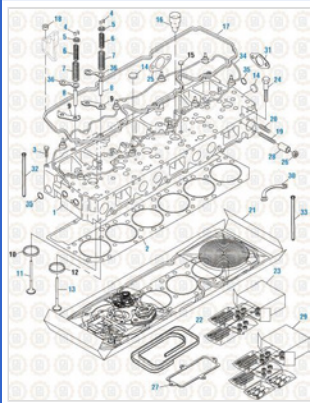

Caterpillar Engine 2019
Cylinder Head - 3176 / C9 / C10 / C11 / C12 / C13 Series

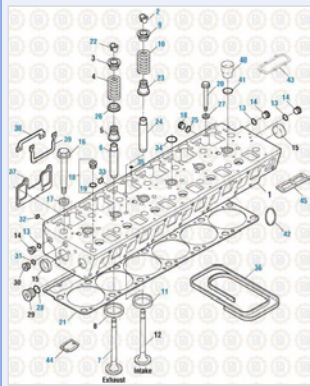

Caterpillar Engine 2019
Cylinder Head - 3126B / C7 - 3100 / C7 Series

Component Of:

SKU	Image	Description
331139-151		VALVE COVER GASKET KIT
331165-154		VALVE COVER GASKET KIT

Copyright © 2020 PAI Industries, Inc.
All rights reserved. All content is property of PAI Industries, Inc. and may not be reproduced or redistributed in any form.

Any reference to OEM names or OEM product identification numbers/descriptions/model numbers is for identification only and does not indicate that it is an OEM part. PAI is not affiliated with Mack Truck, Inc.®, Volvo®, Fuller®, Cummins®, Eaton®, Rockwell®, Caterpillar®, Freightliner®, Hendrickson®, Kenworth®, Detroit Diesel®, International®, Peterbilt®, or Dana®. All Manufacturer's names, numbers, symbols and descriptions are used for reference only. It is not implied that any part listed is the product of these manufacturers.

VALVE COVER GASKET

331280

[331470-156](#)



COVER GASKET KIT

[331473-156](#)

VALVE COVER GASKET KIT

[331503](#)



UPPER GASKET KIT

[331504](#)



UPPER GASKET KIT

[331542](#)

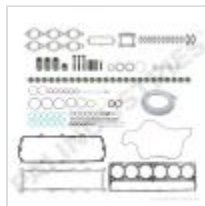

UPPER GASKET KIT

[331560](#)

UPPER GASKET KIT

Cross Reference:

Manufacturer	OEM Number
CATERPILLAR	217-5701
CATERPILLAR	2175701
CATERPILLAR	5P5678-3

Copyright © 2020 PAI Industries, Inc.
 All rights reserved. All content is property of PAI Industries, Inc. and may not be reproduced or redistributed in any form.

Any reference to OEM names or OEM product identification numbers/descriptions/model numbers is for identification only and does not indicate that it is an OEM part. PAI is not affiliated with Mack Truck, Inc.®, Volvo®, Fuller®, Cummins®, Eaton®, Rockwell®, Caterpillar®, Freightliner®, Hendrickson®, Kenworth®, Detroit Diesel®, International®, Peterbilt®, or Dana®. All Manufacturer's names, numbers, symbols and descriptions are used for reference only. It is not implied that any part listed is the product of these manufacturers.