

INTERMEDIATE PISTON RING

EF07150

Description:	INTERMEDIATE PISTON RING
SKU:	EF07150
OEM:	8997
Product Group:	TRANSMISSION
Product Class:	GEARS, SHAFTS, CLUTCHES
UPC Code:	193807077778
Sell Pack:	1 EA
Weight:	0.61 LBS
Warranty:	1 Year

Details:
Intermediate Piston Ring Cummins 4B / 6B engine application

E-Catalog Pages:

Catalog Page	Description
--------------	-------------

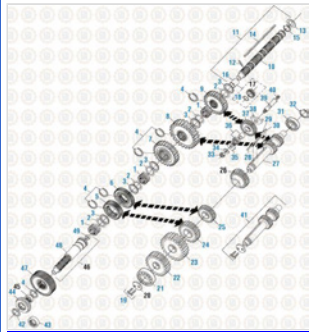

Web Electronic
Main Case Components - Fuller Transmission

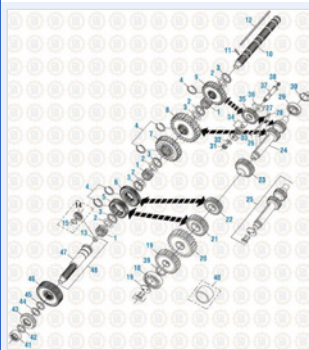

Web Electronic
Main Case Components - Fuller Transmission

Copyright © 2020 PAI Industries, Inc.
All rights reserved. All content is property of PAI Industries, Inc. and may not be reproduced or redistributed in any form.

Any reference to OEM names or OEM product identification numbers/descriptions/model numbers is for identification only and does not indicate that it is an OEM part. PAI is not affiliated with Mack Truck, Inc.®, Volvo®, Fuller®, Cummins®, Eaton®, Rockwell®, Caterpillar®, Freightliner®, Hendrickson®, Kenworth®, Detroit Diesel®, International®, Peterbilt®, or Dana®. All Manufacturer's names, numbers, symbols and descriptions are used for reference only. It is not implied that any part listed is the product of these manufacturers.

INTERMEDIATE PISTON RING

EF07150

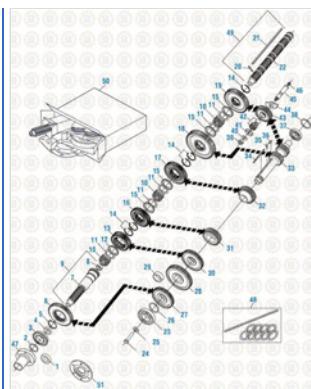

Web Electronic
Main Case Components - Fuller Transmission

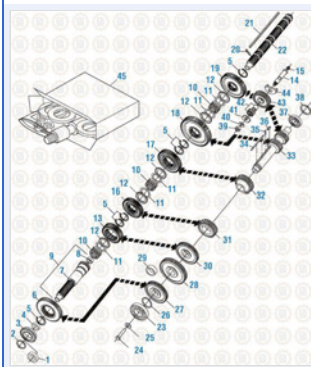

Drive Train 2016
Main Case Components - RT/RTO/RTOO/RTLO 14613 and 14813



Web Electronic
Main Case Components - Fuller Transmission

Component Of:		
SKU	Image	Description
EF65660	-	BEARING AND SEAL KIT
EF65670	-	BEARING AND SEAL KIT
EF65880	-	BEARING AND SEAL KIT
EF65960	-	BEARING AND SEAL KIT
EF66270	-	BEARING AND SEAL KIT
EF66280	-	BEARING AND SEAL KIT
EF66290	-	BEARING AND SEAL KIT

Copyright © 2020 PAI Industries, Inc.
All rights reserved. All content is property of PAI Industries, Inc. and may not be reproduced or redistributed in any form.

Any reference to OEM names or OEM product identification numbers/descriptions/model numbers is for identification only and does not indicate that it is an OEM part. PAI is not affiliated with Mack Truck, Inc.®, Volvo®, Fuller®, Cummins®, Eaton®, Rockwell®, Caterpillar®, Freightliner®, Hendrickson®, Kenworth®, Detroit Diesel®, International®, Peterbilt®, or Dana®. All Manufacturer's names, numbers, symbols and descriptions are used for reference only. It is not implied that any part listed is the product of these manufacturers.

INTERMEDIATE PISTON RING

EF07150

Cross Reference:

Manufacturer	OEM Number
FULLER	8997
FULLER	X-8-997
NAVISTAR	697437R1

Copyright © 2020 PAI Industries, Inc.

All rights reserved. All content is property of PAI Industries, Inc, and may not be reproduced or redistributed in any form.

Any reference to OEM names or OEM product identification numbers/descriptions/model numbers is for identification only and does not indicate that it is an OEM part. PAI is not affiliated with Mack Truck, Inc.®, Volvo®, Fuller®, Cummins®, Eaton®, Rockwell®, Caterpillar®, Freightliner®, Hendrickson®, Kenworth®, Detroit Diesel®, International®, Peterbilt®, or Dana®. All Manufacturer's names, numbers, symbols and descriptions are used for reference only. It is not implied that any part listed is the product of these manufacturers.