

SPACER

EF10830-254



| | |
|-----------------------|-------------------------|
| Description: | SPACER |
| SKU: | EF10830-254 |
| OEM: | 14712 |
| Product Group: | TRANSMISSION |
| Product Class: | GEARS, SHAFTS, CLUTCHES |
| UPC Code: | 193807021634 |
| Sell Pack: | 1 EA |
| Weight: | 0.16 LBS |
| Warranty: | 1 Year |



Details:

Spacer
 .253in-.255in Thick

E-Catalog Pages:

| Catalog Page | Description |
|--------------|-------------|
|--------------|-------------|

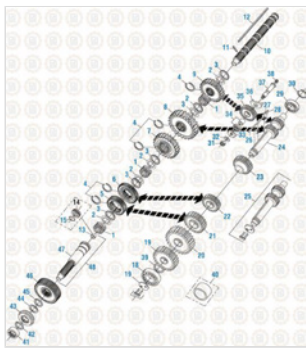

Web Electronic
 Main Case Components - Fuller Transmission

Copyright © 2020 PAI Industries, Inc.
 All rights reserved. All content is property of PAI Industries, Inc, and may not be reproduced or redistributed in any form.

Any reference to OEM names or OEM product identification numbers/descriptions/model numbers is for identification only and does not indicate that it is an OEM part. PAI is not affiliated with Mack Truck, Inc.®, Volvo®, Fuller®, Cummins®, Eaton®, Rockwell®, Caterpillar®, Freightliner®, Hendrickson®, Kenworth®, Detroit Diesel®, International®, Peterbilt®, or Dana®. All Manufacturer's names, numbers, symbols and descriptions are used for reference only. It is not implied that any part listed is the product of these manufacturers.

SPACER

EF10830-254

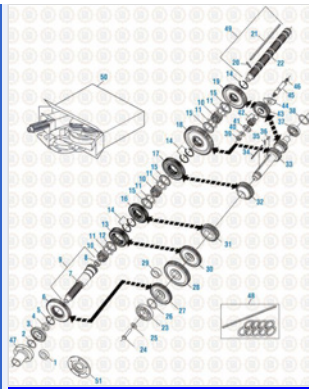

Web Electronic
Main Case Components - Fuller Transmission

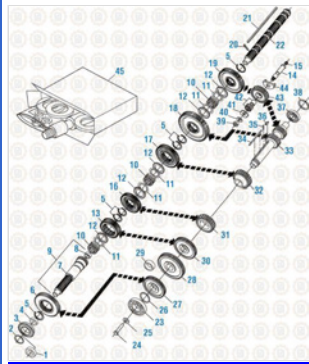

Drive Train 2016
Main Case Components - RT/RTO/RTOO/RTLO 14613 and 14813

Drive Train 2016
Main Case Components - RTLO 16618



Web Electronic
Main Case Components - Fuller Transmission

Component Of:

| SKU | Image | Description |
|-------------------------|-------|-----------------|
| EF26730 | . | SMALL PARTS KIT |
| EF61520 | . | SMALL PARTS KIT |

Cross Reference:

| Manufacturer | OEM Number |
|--------------|------------|
| FULLER | 14712 |

Copyright © 2020 PAI Industries, Inc.
All rights reserved. All content is property of PAI Industries, Inc, and may not be reproduced or redistributed in any form.

Any reference to OEM names or OEM product identification numbers/descriptions/model numbers is for identification only and does not indicate that it is an OEM part. PAI is not affiliated with Mack Truck, Inc.®, Volvo®, Fuller®, Cummins®, Eaton®, Rockwell®, Caterpillar®, Freightliner®, Hendrickson®, Kenworth®, Detroit Diesel®, International®, Peterbilt®, or Dana®. All Manufacturer's names, numbers, symbols and descriptions are used for reference only. It is not implied that any part listed is the product of these manufacturers.

SPACER

EF10830-254

| | |
|----------|----------|
| FULLER | 18702 |
| NAVISTAR | 310675C1 |
| NAVISTAR | 499738C1 |

Copyright © 2020 PAI Industries, Inc.

All rights reserved. All content is property of PAI Industries, Inc. and may not be reproduced or redistributed in any form.

Any reference to OEM names or OEM product identification numbers/descriptions/model numbers is for identification only and does not indicate that it is an OEM part. PAI is not affiliated with Mack Truck, Inc.®, Volvo®, Fuller®, Cummins®, Eaton®, Rockwell®, Caterpillar®, Freightliner®, Hendrickson®, Kenworth®, Detroit Diesel®, International®, Peterbilt®, or Dana®. All Manufacturer's names, numbers, symbols and descriptions are used for reference only. It is not implied that any part listed is the product of these manufacturers.