

SYNCHRONIZER KIT

GSK-2533

| | |
|-----------------------|-------------------------------|
| Description: | SYNCHRONIZER KIT |
| SKU: | GSK-2533 |
| OEM: | 208SH99 |
| Product Group: | TRANSMISSION |
| Product Class: | SYNCHRONIZERS & RELATED PARTS |
| UPC Code: | 193807192686 |
| Sell Pack: | 1 EA |
| Weight: | 5.75 LBS |
| Warranty: | 2 Years |

Details:

Synchronizer Kit
 For GSA-2505
 Mack T2080 / T2090 / T2100 / T2130 / T2180 / T309L / T310/M Transmission Application

E-Catalog Pages:

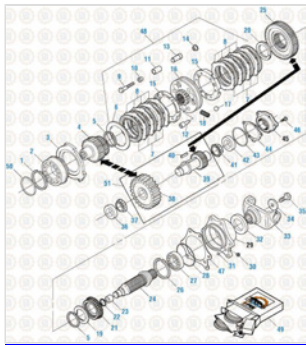
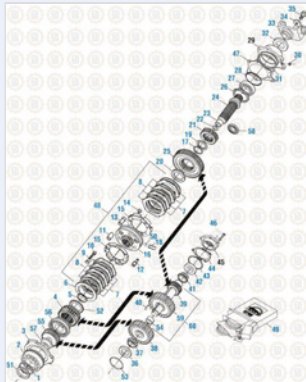
| Catalog Page | Description |
|--|--|
|  | <p>Drive Train 2016 Rear Case Components - Original Design Synchronizer - T2080, T2090 and T2100</p> |
|  | <p>Drive Train 2016 Rear Case Components - T2130 and T2180</p> |

Copyright © 2020 PAI Industries, Inc.

All rights reserved. All content is property of PAI Industries, Inc. and may not be reproduced or redistributed in any form.

Any reference to OEM names or OEM product identification numbers/descriptions/model numbers is for identification only and does not indicate that it is an OEM part. PAI is not affiliated with Mack Truck, Inc.®, Volvo®, Fuller®, Cummins®, Eaton®, Rockwell®, Caterpillar®, Freightliner®, Hendrickson®, Kenworth®, Detroit Diesel®, International®, Peterbilt®, or Dana®. All Manufacturer's names, numbers, symbols and descriptions are used for reference only. It is not implied that any part listed is the product of these manufacturers.

SYNCHRONIZER KIT

GSK-2533

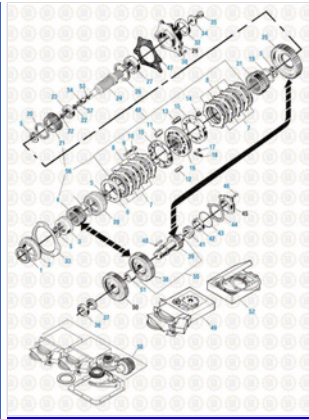

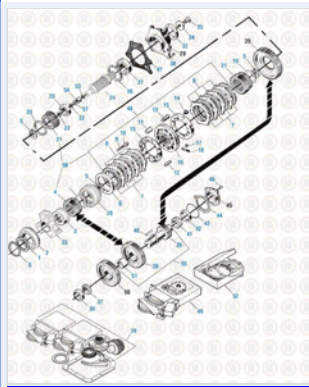

Drive Train 2016
Rear Case Components - T309L and T310



Drive Train 2016
Rear Case Components - T310M

Consists Of:

| SKU | OEM | Image | Description | Quantity |
|--------------------------|-----------|---|-------------------|----------|
| GSD-2525 | 495KB361 |  | SYNCHRONIZER DISC | 8 |
| GSD-2526 | 495KB367 |  | SYNCHRONIZER DISC | 8 |
| GPN-2521 | 301KC240B | . | SYNCHRONIZER PIN | 3 |
| GPN-2522 | 301KC241B | . | SYNCHRONIZER PIN | 3 |

Copyright © 2020 PAI Industries, Inc.
All rights reserved. All content is property of PAI Industries, Inc. and may not be reproduced or redistributed in any form.

Any reference to OEM names or OEM product identification numbers/descriptions/model numbers is for identification only and does not indicate that it is an OEM part. PAI is not affiliated with Mack Truck, Inc.®, Volvo®, Fuller®, Cummins®, Eaton®, Rockwell®, Caterpillar®, Freightliner®, Hendrickson®, Kenworth®, Detroit Diesel®, International®, Peterbilt®, or Dana®. All Manufacturer's names, numbers, symbols and descriptions are used for reference only. It is not implied that any part listed is the product of these manufacturers.

SYNCHRONIZER KIT

GSK-2533

| | | | | |
|--------------------------|---------|---|-------------|---|
| GDB-1665 | 48AX17 |  | DETENT BALL | 6 |
| GSP-1669 | 58AX276 |  | SPRING | 6 |

| Cross Reference: | |
|------------------|------------|
| Manufacturer | OEM Number |
| MACK | 208SH99 |
| MACK | 208SH97 |

Copyright © 2020 PAI Industries, Inc.
 All rights reserved. All content is property of PAI Industries, Inc, and may not be reproduced or redistributed in any form.

Any reference to OEM names or OEM product identification numbers/descriptions/model numbers is for identification only and does not indicate that it is an OEM part. PAI is not affiliated with Mack Truck, Inc.®, Volvo®, Fuller®, Cummins®, Eaton®, Rockwell®, Caterpillar®, Freightliner®, Hendrickson®, Kenworth®, Detroit Diesel®, International®, Peterbilt®, or Dana®. All Manufacturer's names, numbers, symbols and descriptions are used for reference only. It is not implied that any part listed is the product of these manufacturers.