

Steering Wheel Remover/Lock Plate Tool and Pivot Pin Remover

To remove steering wheel:

1. Make sure that the front wheels are pointing straight ahead.
2. Disconnect the negative battery cable.
3. Remove horn ring/center horn pad assembly.
4. If applicable, remove airbag module as per vehicle manufacturer instructions.
CAUTION: Do not attempt to remove airbag module without disabling it first as per vehicle manufacturers instructions.
5. Remove steering wheel retaining nut.
6. Check for alignment marks on steering wheel hub and shaft.
If no marks exist, mark appropriately.
7. Carefully remove and note location of horn contact components.
8. Select appropriate bolts to thread into steering wheel hub, or for non threaded applications use J-style puller legs.
9. With center screw threaded into T-bar, thread bolts or insert legs into hub of steering wheel.
10. Hand tighten by rotating center screw clockwise while aligning with center of steering shaft.
11. Insure that bolts are at even heights and continue to tighten with a 1/2" wrench or socket until steering wheel is pressed free of shaft.

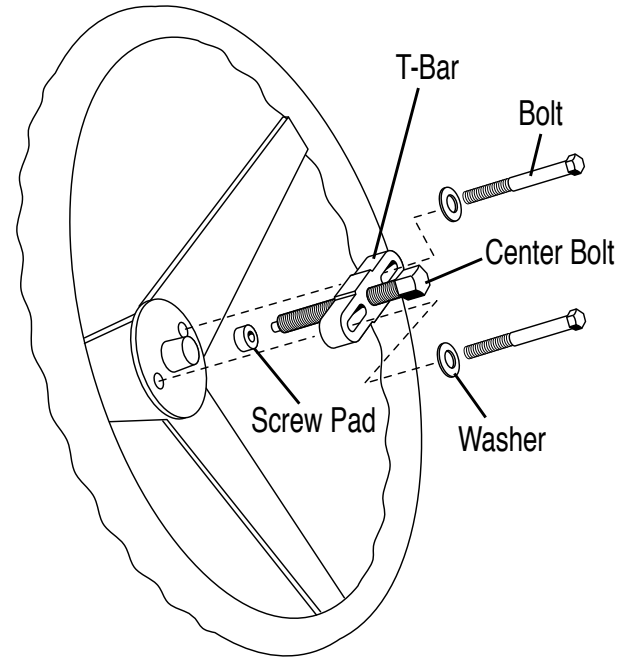

Lock plate removal/installation:

1. With steering wheel removed, choose appropriate forcing screw and thread onto steering shaft as far as possible.
2. Place the U-shaped part of the tool over the forcing screw with the open end against the lock plate.
3. Place the washer over the forcing screw followed by the nut.
4. Thread the nut onto the screw and tighten with a 7/8" wrench until the lock plate has been depressed just enough to allow removal of the retaining ring. Do not depress any further than this or damage may occur.
5. With retaining ring removed, turn the nut counter clockwise to release pressure on the lock plate.
6. Once repairs are completed, replace lock plate using the same procedure.

Pivot pin removal:

1. Unthread the press housing from the small threads of the screw. The screw threads into the housing for storage, so parts will not get lost.
2. Make sure you have the nut, washer and then the housing in position with open end towards the small threads.
3. Thread the screw into the pivot pin as far as it will go.
4. Hand tighten the nut while holding the center screw until the puller housing is pressed against steering column.
5. Continue to tighten the nut with a 12mm wrench while holding the center screw 3/8" wrench or socket until the pivot pin is pulled from the housing.

⚠ WARNING: If the vehicle is equipped with an airbag system, do not attempt to service the steering wheel or related components without first disabling the airbag system. Severe injury may occur if the airbag is accidentally deployed. Consult your vehicle manufacturer for disabling procedure.

ALWAYS WEAR EYE PROTECTION WHILE USING THIS TOOL.

Replacement Parts:

| | |
|--------------------------|----------|
| M8 x 1.25 x 90mm Bolt | W89704-1 |
| 3-1/2" x 5/16" NF Bolt | W89704-2 |
| 3-1/2" x 3/8" NC Bolt | W89704-3 |
| 4" x 5/16" NC Bolt | W89704-4 |
| Lock Plate Remover Clamp | W89704-5 |
| Nut | W89704-6 |
| Washer | W89704-7 |

GM Steering Wheel

| | |
|--------------------------|-----------|
| Puller Legs | W89704-8 |
| M14 x 15 Forcing Screw | W89704-9 |
| 9/16" - 18 Forcing Screw | W89704-10 |
| Screw Pad | W89704-11 |
| GM Puller Leg Adapter | W89704-12 |
| T-Bar | W89704-13 |
| Center Bolt | W89704-14 |
| Pivot Pin Remover | W89704-15 |