

PIAA LP530

Installation Instructions

Thank you very much for purchasing PIAA product.
Please read this entire manual before installation and use of this product.

※ The  **CAUTION** and  **WARNING** marks indicated in this manual are cautionary points related to the installation of the product.

To ensure safe and secure installation of the product, please follow these points closely.

To user

… Please keep this manual and a receipt which can be recognized the shop name you bought at.
When giving this product to a third party, always include this manual together with the product.

To shop owners installing the product

… After installation of the product, make sure the customer is provided with this owner' s manual.

Please read the cautionary points before installation to ensure safe utilization of the product.

WARNING

- Do not touch the bulb while lit or immediately after switching it off because the lamp remains extremely hot. Severe burns may occur as a result. Also, care should be taken to prevent water from making contact with the lens. This may cause the lens to crack or impair proper functioning.
- The lamp becomes very hot when turned on. When parking your car near flammable items such as dried leaves, turn off the lamp as it may cause a fire.
- Do not look directly into the light for long periods. Doing so may cause eye irritation or visual impairment.

CAUTION

- The lamp and the switch harness are intended for automobile use. Do not use for any other purpose.
- This lamp is intended for use in rain (day or night), during foggy or snowy conditions where visibility is hampered. Do not use during normal driving conditions.
- Do not operate the switch while driving.
- If the lamp is kept on when the engine is not running, it may drain the battery.
- Make sure the lamp is installed securely before driving the vehicle. If an abnormality is found, adjust it immediately.
- Check for any loose screws that hold the lamp in place before driving. If you find any loose screws or bolts (if a bracket is used), tighten them securely. If you notice a loose part while driving, inspect the section immediately and make the necessary adjustments.
- Avoid repeatedly turning the lamp off and on as it may reduce the overall life of the bulb.
- Some of vehicles are produced high voltages of electric charge when you start engine. Avoid loading extra voltage to lamps, please turn the switch off when you start engine.
- Avoid needless disassembly of the lamp or the switch harness as it may cause it to fail.
- If the lamp and/or the switch harness is removed and set aside for safekeeping, wipe away all dust or grime and store in a place free of moisture.
- If the lens is cracked or damaged in any way, verify whether there is any damage to the harness or the switch harness that it is connected to. If there is any damage to the cord covering, replace it immediately.
- Avoid injury when replacing the harness and the switch harness. Please dispose of it as a non-combustible item.

Please read the installation procedures thoroughly beforehand.

CAUTION

- This lamp is a hanging type and uses a bracket. If using it upright, set the bracket up correctly so that the PIAA logo is properly displayed.
- In order for the lamp to perform at its full potential, use relay harnesses manufactured by PIAA.
- All work procedures should be carried out in a location with adequate space. Place the shift lever in neutral or in the parking position. Turn off the engine and set the side brake.
- Make sure the engine compartment is adequately cool before starting work. Do not begin work if engine parts such as radiator, oil-cooler or turbo part are still hot.
Be extremely careful when handling the lamp and the switch harness. If dropped or excessive shock is applied to the lens, the bulb or the switch harness, it may cause irreversible damage.
- Do not add additional holes to the main body of the lamp. Also, do not apply adhesives or stickers to the lamp parts.
- Do not modify the lamp harness or the switch harness in any way. Such modifications may cause it to overheat or short. In some cases, it may cause the vehicle to catch fire. PIAA will not be liable for damage caused by such modifications.
- When removing the battery terminals, do not touch the (-) and (+) terminals simultaneously. An electrical shock may occur. Wear rubber gloves when carrying out such work procedures.
- Make sure the (-) and (+) terminals do not make contact with metal. It can be extremely dangerous if a short occurs.
- Make sure all bolts are tightly secure. If there are any loose bolts tighten them accordingly.
- After installing the lamp, adjust the lamp so the beam shines at least 40m in front of the vehicle. Also, adjust the lamp a little toward the left so that it does not shine directly into the eyes of the opposing driver of a vehicle. (as traffic laws stipulate - refer to p.8 for adjustment procedures)
- After installing the lamp, make sure the headlamps, wipers and horn are working normally.
- When the battery terminal is removed, memory related to the clock, radio, audio system etc, will be affected. After all work procedures are completed, reset to the original settings. (For adjustment procedures refer to your car' s instruction manual)

Caution Regarding Wiring / Please read thoroughly

WARNING

- When doing wiring work, strictly follow the cautionary points mentioned below. Incorrect or faulty wiring may cause the lamp to operate improperly. In some cases, it may cause the vehicle to catch fire.

CAUTION

- Before you begin always remove the (-) and (+) terminals.
Always remove the (-) terminal first and make sure a short does not occur.
- When removing the battery terminals, always turn the key to OFF and remove it. Turn all other electrical units off such as the light switch.
- When removing the battery terminals, if a cord (for an electrical unit) is connected, wind a length of vinyl tape around the (-) and (+) terminals to clearly identify them.
- Verify the (+) terminal (white) and earth (black) before connecting.
- Do not obtain (+) voltage from the alternator.
- Obtain the (+) current necessary for the switch from the (+) current used for the light switch.
(Do not use the same current used for a computer, radio or audio system)
- Install the switch harness in a position where it will not make contact with high temperature surfaces such as the engine, radiator or engine compartment.
- Arrange the switch harness so that it does not make contact with moving parts.
- Do not place the switch harness on high-voltage wires such as brake or air-conditioning wires.
- If the switch harness makes contact with a part of the engine, apply a length of ordinary cushioned tape around the harness.
- When connecting the connector, insert until you hear an audible "click"
- When removing the connector, hold the main body of the connector and pull it out. If excess force is used to pull the cord, it may damage the connection, which could cause it to overheat.
- Make sure the harness does not sag. Use a harness band of vinyl tape to secure it in place to wiring inside the engine compartment.
- Before connecting it to the battery, verify the wiring arrangement.
- When connecting the battery terminal and or other electrical units, do not mistake the (-) and (+) terminals. Always start with the (+) terminal.
- After all wiring is complete, confirm that it works properly. If it fails to activate, refer to "[4] Troubleshooting" section of this manual.

Product Details

※ Verify all the parts are included. If a part is missing, please contact your local distributor.

① Lamp main unit (2 units)

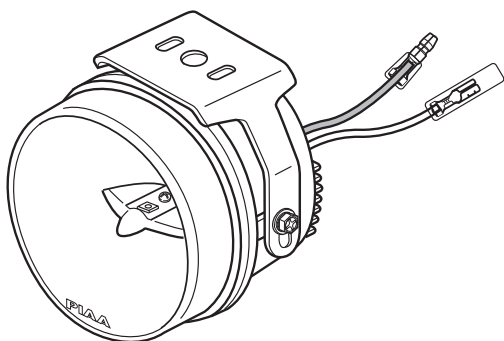

② Switch harness set [1 set]

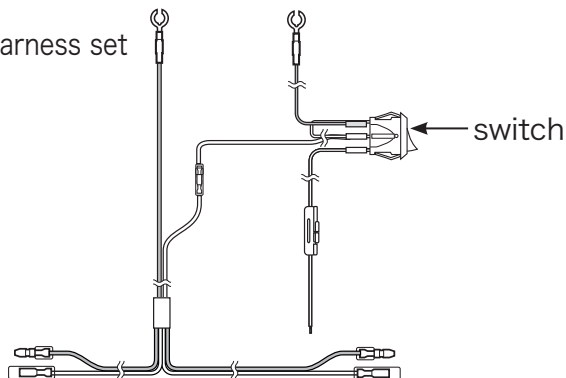

③ Double-stick tape (2 pcs)

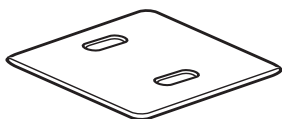

④ One-touch connector (1 pc)

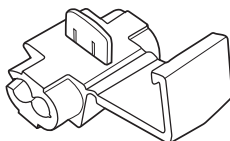

⑤ Wire tie (5 pcs)

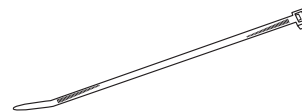

Tools Required

※ Please use the tools indicated below.

● Tape

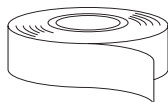

● Phillips head driver

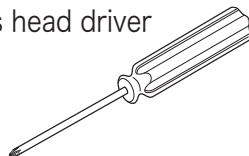

● Pliers

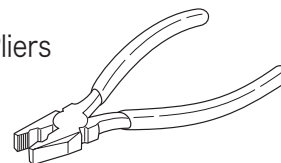

● Electric drill

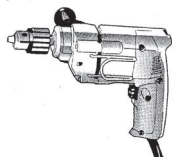

● Holesaw(ϕ 20mm)

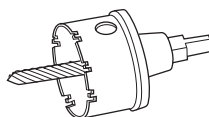

● File



[1] Lamp installation preparations and temporary setup

- Using the holes in the lamp bracket, the height from the lamp body to the installation surface can be adjusted. Depending on the top and bottom measurements as well as shape.
- In case the mounting surface is not flat position or is not enough space of it's surface, please make sure to fix the lamp stably by using double-stick tape and screws(sell separately).

Mounting that combines bracket and lamp

Type A

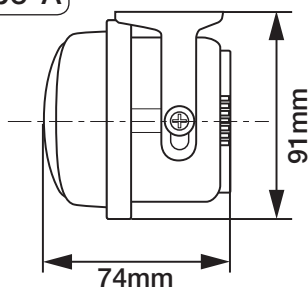

Type B

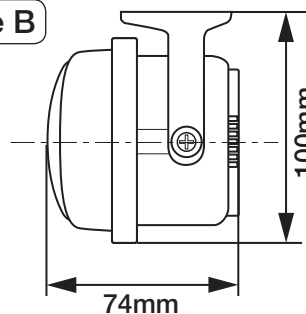

CAUTION

- When using a bracket available on the market, make sure the bolts you remove from the vehicle does not hinder its performance.
- Do not install on an unstable location, it may come lose while driving. This may affect the overall life of the bulb. In addition it may damage the vehicle or the main body of the lamp. Make sure you install the lamp on a stable and secure location.
- Do not install on a vertically-surface (refer the image on right hand).

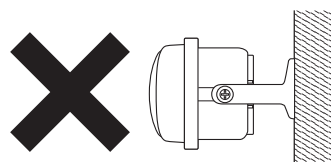

◆ When you have decided the installation method.....

- (1) Rearrange the bracket according to your needs, and apply double-side tape (Item 3) and one-side tape as shown in the diagram below.
- (2) Hold the lamp up to where it will be installed on the vehicle. Verify the gap between the lamp and surrounding obstacles.

Check !

- Make sure the lamp can be adjusted up and down (beam must be adjusted so that it shines at least 40m ahead of the vehicle.) If it cannot be adjusted, it must be re-installed.
- There must be between 30mm to 35mm on either side of the lamp to allow for proper adjustment.
- If using a screw, make sure there is adequate space between the bracket and the lamp (where screw will be inserted).

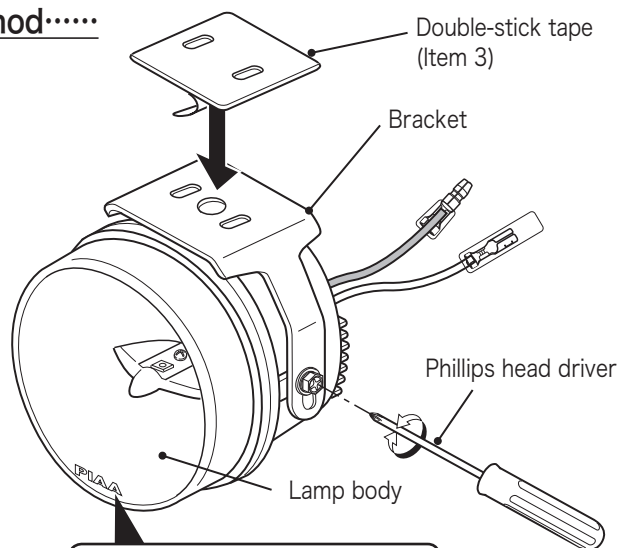

Make sure the installation position is correct and the logo will not be upside down.



- Temporarily set the bracket with tape.

CAUTION

- Make sure to set position properly before permanently setting the lamp. Also, thoroughly clean the surface of the installation position beforehand.
- Make sure to remove the tape glue on the vehicle body after installation.

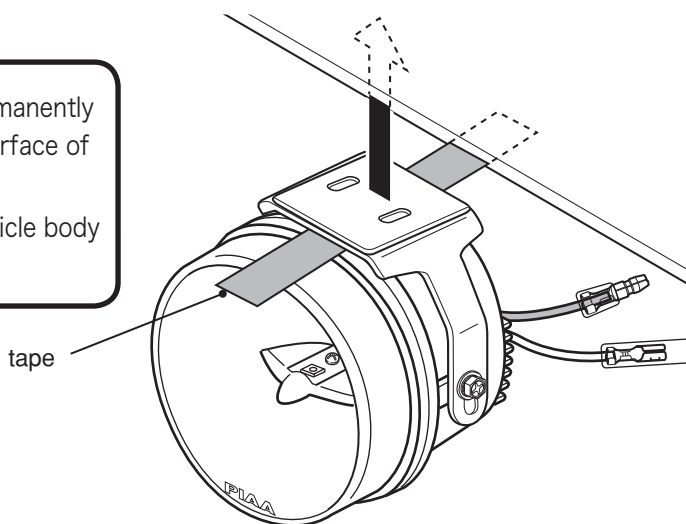

[2] Switch Harness Installation Sequence

The numbers shown in the figure below indicate the sequence the parts should be installed.

1

Remove the bullet connector of "the switch harness".



9

Attach the (-) cord to the body earth.

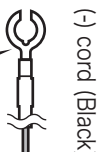

5

Bring the bullet connector which took on **1** into the interior of the vehicle and connect to the bullet connector.

Switch harness

8

Attach the (-) cord to the body earth or the (-) battery.

(-) cord (Black)

4

Drill a hole of 20mm diameter in the dash board or interior switch cover, then mount the switch stably.

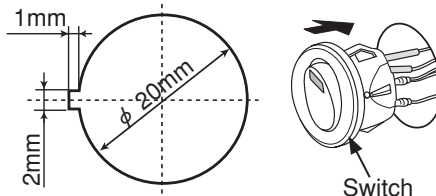

※ If the hole is bigger than 20mm diameter, the switch does not fix stably. Recommend to make a smaller hole, then adjust the size by inches.

6

Take the (+) cord (white) and using the one-touch connector (Item 4), tie it together to the vehicle's (+) cord.

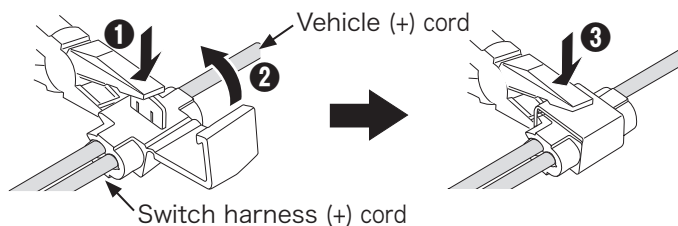

3

Remove the (+) terminal from the battery.

2

Remove the (-) terminal from the battery.

11

Attach the (+) terminal to the battery.

10

Attach the (-) terminal to the battery.

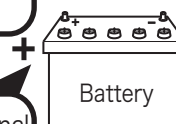

7

Connect bullet connectors to the lamp harnesses.

Lamp

Lamp

12

Harness

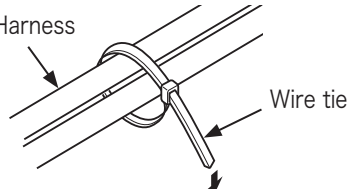

Wire tie

After lamp has been installed, verify the switch harness does not make contact with the engine's moving parts or sections that emit extreme heat. Use the wire tie included (Item 5) and secure to harnesses inside engine compartment.

[3] Lamp Installation Procedures

- 1** Temporarily set the bracket with tape and then mark the correct position.

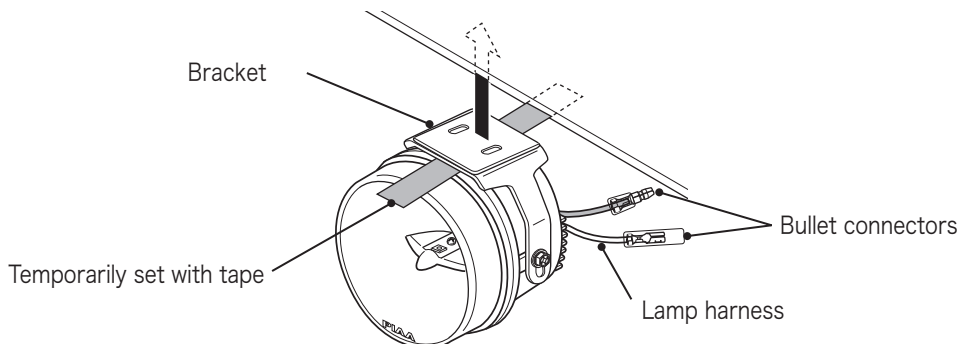

- 2** Remove the lamp harness bullet connectors and take out the lamp.

- 3** Install the lamp according to the marking made prior to installation.

◆ If using only the double-side tape.

Peel the protective sheet from the double-sided tape (Item 3) and apply.

⚠ CAUTION

- When using the double-side adhesive tape, clean the surface where tape will be applied. Use a clean cloth or sponge and make sure dirt, grease, wax etc., are completely removed. If substances cannot be removed, it may not adhere properly. In particular, avoid using leather wax, tire wax and also any type of organic solvent.
- When used in low temperatures, the adhesive substance tends to lose its strength. Use a drier or simply warm up the adhesive surface before applying. When using a drier, avoid moving it too close to the bumper as it may cause it to deform.
- After installation, avoid excess speeds and do not wash for 1 to 2 days.
- If applied incorrectly, a special double-sided adhesive tape is available at your local PIAA dealer.

◆ If using screws(M4 bolt or screw) to fix lamp stably.

- (1) Loosen (+) bolt with Philip' s head driver and remove the bracket from the lamp.
- (2) Peel off the protective sheet from the double-sided tape and apply it to the bracket.
- (3) Fix the bracket in place with the screws.
- (4) Install the lamp onto the bracket.

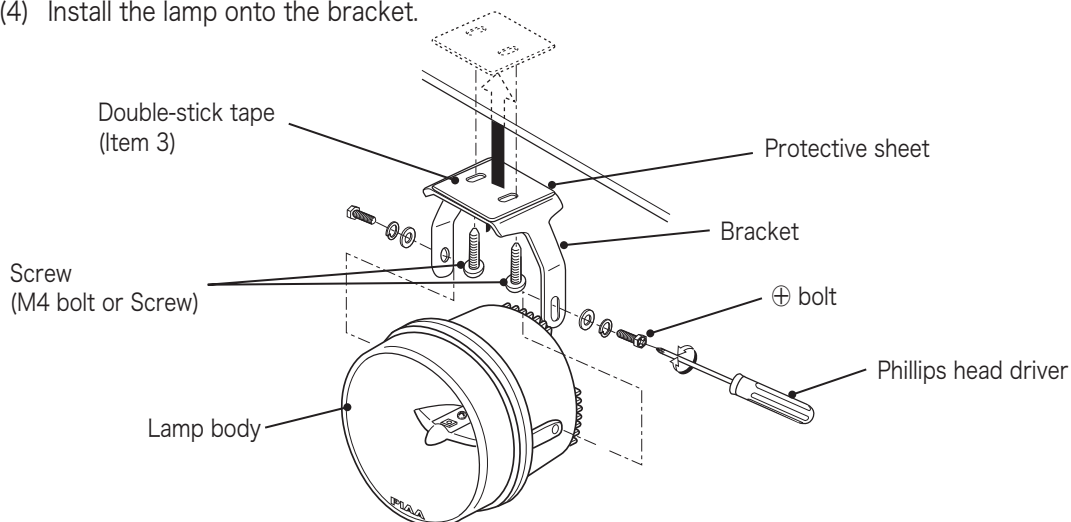

4 DRIVING / Spot Light Aiming

Typically, driving lights are mounted above the front bumper about 14 cm -30 inches from the ground to provide extra high beam illumination. Driving lights can be mounted below the bumper, although they will not be as effective because the light will hit the ground sooner and reduce the range of the light.

Visual aim is made with the center of the beam hot spot 1.5 inches below the lamp center at 25feet with the lamp facing straight forward. (see below.)

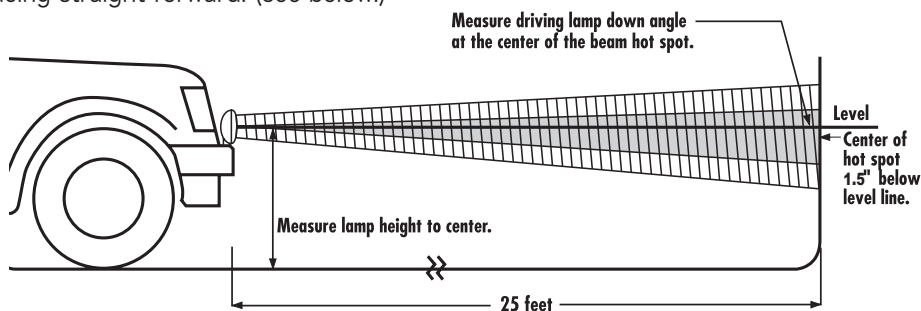

CAUTION

- Do not use driving lights into oncoming traffic. Driving lights should never be the only forward light source. Driving lights should only be used with the headlamp high beams.

Fog Light Aiming

There are two important issues to address when installing fog lights, the first is to minimize the amount of return glare into the drivers eyes, and the other is to minimize glare into oncoming eyes. Both of those issues must be accomplished while putting as much light as possible on the road.

These fog/foul weather light aiming instructions are suggestions taken from common practice and the S.A.E. standard J583.

Some modifications to these instructions may be necessary to minimize glare.

Visual aim is made with the top of the beam 4 inches below the lamp center at 25 feet with the lamp facing straight forward. (See below.)

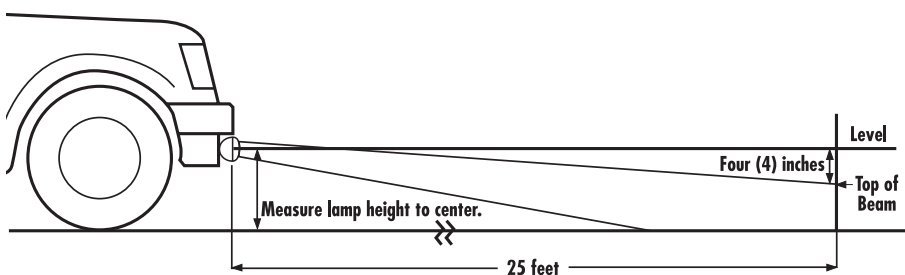

CAUTION

- Only use fog lights if they are aimed properly. Fog lights should never be the only forward light source. Fog lights should be used with headlamp low beams.

[4] Troubleshooting.....

Verify each section according to the following.

1 After installation, if the lamp does not activate

→ Check the wiring and make sure there are no faulty or irregular connections .

● If the switch illumination does not light up.

- Verify the (+) wire from the switch is properly connected. If it is not correctly connect it will not activate.
- Verify the fuse located on the vehicle' s wiring system. (the switch' s (+) wire should be connected to the fuse box). If it is burned out, connect it to another circuit.
- If the switch itself is faulty, the same symptoms may exist. We recommend that the entire switch unit be replaced.
- Check the fuse for the switch harness. If it is burned out, follow instructions indicated in [3] Fuse replacement Procedures].

● The switch illumination lights up but when operating does not work.

- Check the connecting (-) cord to the body earth.
- There may be cases where each terminal related to specific sections may be incorrectly connected. Check for any lose wires and also for dirt or grime.
- Check the switch opelation If an abnormality is found, replace it accordingly.

2 If the bulb suddenly fails to light up ...

- Check the fuse located on the vehicle' s wiring system. If it is burned out, replace accordingly.
- Check the fuse for the switch harness. If it is burned out, follow instructions indicated in [**3**] Fuse replacement Procedures].
- There may be cases where each terminal related to specific sections may be incorrectly connected. Check for any loose wires and also for dirt or grime.
- Check the switch operation if an abnormality is found, replace it accordingly.

3 Fuse replacement Procedures

- A short circuit may have occurred. Check the wiring system. If any type of damage is found replace accordingly. (Non-replacement may pose a potential danger) (Short circuits are mainly caused when wires are caught in the assembly or when there is a gap in the sleeve connected to the lamp harness).