

PRO SERIES *THE MAESTRO*TM

POWER PROBE TEK

**PRO
SERIES**



Power **Probe** Tek



TABLE OF CONTENTS

Introduction	3
Safety	4
Appearance and Controls	5
EZ Learning	7
Guided Diagnostics	8
Start Up	9
Main Menu	10
Mode Navigation	11
Testing and Measuring Operations	
• DC Voltage in VDC Mode	12
• Activating Components	13
• Resistance Testing on OHM Mode	14
• Power Feed Test	15
• AC Voltage Measurement (RMS)	17
• AC Voltage Measurement (P to P)	18
• Frequency Measurement	19
• Trace Mode	20
Advanced Testing Operations	
• Fuel Injector Mode	23
• Power Probe TEK Pro Series APP.....	25
• Pairing	27
Tool Repair Operations	28
Specifications	29



INTRODUCTION



Thank you for purchasing the Pro Series *Maestro*[™] Diagnostic Electronic Circuit and Component Tester. This is the first of our Pro Series line of tools made for Professionals. With powerful multimeter functions, advanced diagnostic modes, easy to read color LCD display, and a new rugged dust and water resistant housing. The Pro Series *Maestro*[™] is designed to give you years of trouble free testing. Also, an updateable and useful app that will expand your tools capabilities and give you access to answers and solutions that you need.

The unique configuration of Power Probe testers gives them many advantages over using conventional test lights or multimeters for circuit testing.

(1) Since the Pro Series *Maestro*[™] is connected to the battery, you can apply battery power or battery ground directly to the tip of the tool. You can energize and activate components to verify their correct operation. This is real dynamic component testing and the only true way to test an active component.

(2) Pro Series *Maestro*[™] is always connected to the vehicle's battery, so the tool maintains a permanent connection to the source power and ground voltage. Circuit voltage checks are quickly performed with just a single probe connection, unlike using two meter leads.

(3) Using the Pro Series *Maestro*[™], all your voltage checks are referenced back to the source battery and account for every connection and possible voltage drop between the source and the probe tip.

(4) Automatic Voltage Drop Indication. When probing a circuit, if the voltage measured at the tip is 0.5 volts lower (or more) than the source battery voltage, the red LED will not illuminate, and no tone will sound. This will instantly alert you that there is a voltage drop that may need to be investigated or repaired.



SAFETY

CAUTION - PLEASE READ

To avoid possible electric shock or personal injury, and to avoid damage to the Power Probe or item being tested, please use the Power Probe according to the following safety procedures:

- Power Probe TEK recommends reading this manual before using the *Maestro*[™].
- This product is designed to be powered from DC power sources such as found in Automotive, Small Craft marine, and Small Craft Aviation electrical system and will be damaged if connected to line voltage.
- Do not connect to electrical systems with higher than rated voltage specified in this manual.
- Do not test voltage exceeding the rated voltage on the *Maestro*[™].
- When testing voltage exceeding 30V AC RMS, 42V AC Peak, or 60V DC, be particularly careful to avoid any electrical shock.
- Check the *Maestro*[™] case for cracks or damage. Damage to the case can leak high voltage, causing a potential electrocution risk.
- Check the *Maestro*[™] cables for any insulation damage or bare wires. If damaged, do not use the tool. Please contact Power Probe TEK Technical Support.
- Use only shrouded leads and accessories authorized by Power Probe to minimize exposed conductive electrical connections to eliminate shock hazard.
- Do not open the *Maestro*[™] as there are no servicable parts inside. Opening the *Maestro*[™] voids the warranty. All repairs should only be performed by authorized Power Probe service centers.
- When maintaining the *Maestro*[™], use only replacement parts specified by the manufacturer.
- Use only in well ventilated areas. Do not operate around flammable materials, vapor, or dust.
- Be careful when energizing components that have moving parts, as assemblies containing motors, or high powered solenoids.
- Power Probe TEK shall not be liable for damage to vehicles or components caused by misuse.
- Power Probe TEK shall not be held liable for any harm caused by unintentional or intentional misuse of our products or tools.



APPEARANCE AND CONTROLS

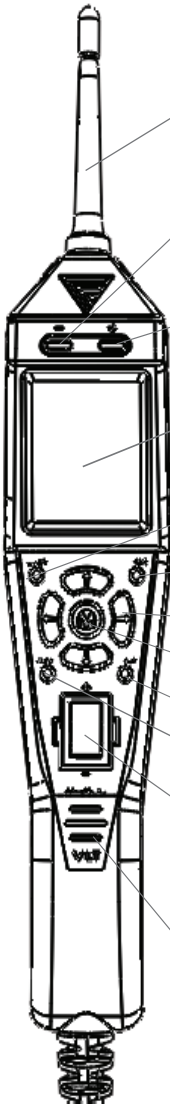

- 1** Removeable Probe Tip uses standard 4mm banana type connector enabling use of different probes, leads, or extensions.
- 2** LED, Green (-) Will light indicating a path to ground. More than 10 Ω resistance and/or more than 0.5 volts on a ground circuit, the Green LED will not illuminate.
- 3** LED, Red (+) Will light indicating (Batt +) Battery Positive. If the circuit voltage drop is more than 0.5 volts from battery voltage, the Red LED will not illuminate.
- 4** Color Screen - Large Hi-Res LCD display shows multiple readings on the one screen. A graphic interface identifies what mode you're in.
- 5** Button, "Clear" used to clear Min/Max in Multi-meter modes.
- 6** Button, "Pair" used to connect to the APP.
- 7** Button, "Up", "Down", "Left", "Right" Used to navigate the menus.
- 8** Button, Center; "MODE" Select - Used to select a test mode when navigating menus.
- 9** Button, "Flip" Used to turn the screen content upside down.
- 10** Button, "Mute" Used to turn the Speaker-Tone On/Off.
- 11** Rocker Switch (replaceable) Part #PPTK0021 - When rocker switch is pressed forward, battery power is applied to the probe tip. When rocker switch is press rearward, battery ground is applied to the probe tip. Can only be used when in either of the DC voltmeter modes.
- 12** Speaker - Distinct tones for power or ground.



APPEARANCE AND CONTROLS

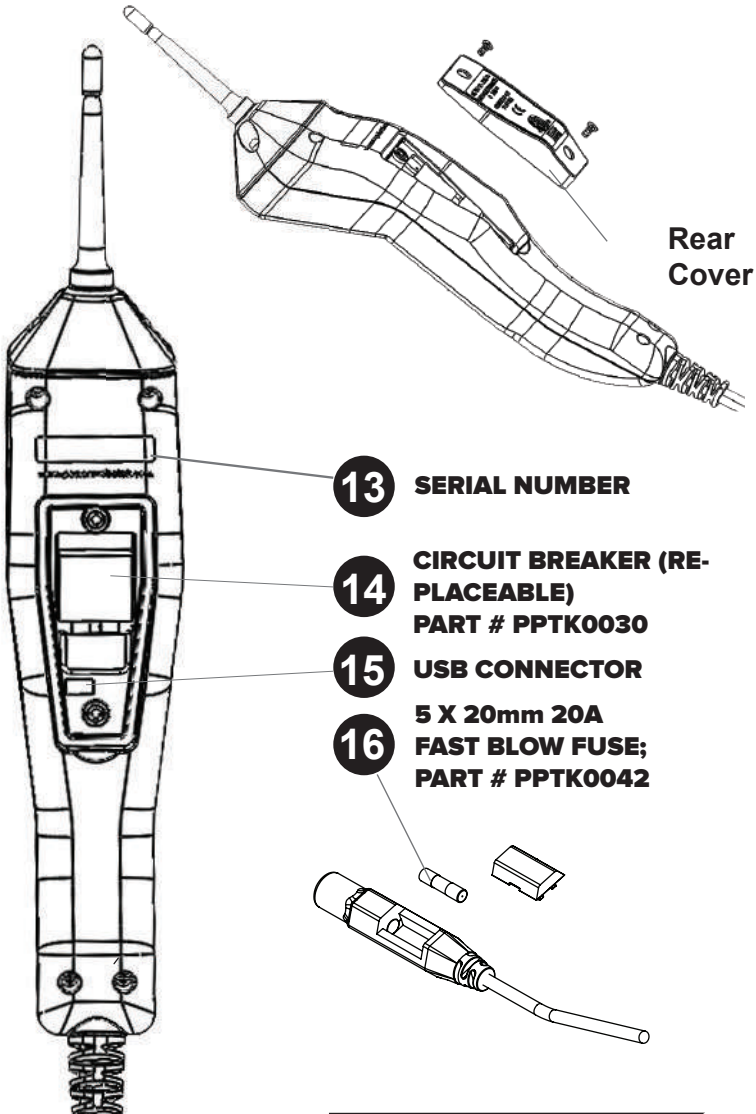

Rear
Cover

- 13** SERIAL NUMBER
- 14** CIRCUIT BREAKER (RE-PLACEABLE)
PART # PPTK0030
- 15** USB CONNECTOR
- 16** 5 X 20mm 20A
FAST BLOW FUSE;
PART # PPTK0042



INTRODUCTION TO EZ LEARNING

EZ Learning Mode will guide you through a step by step familiarization of the *Maestro*[™], showing you how to operate the tool and how the probe responds in certain testing conditions.

From the Main Menu select the EZ Learning icon. EZ Learning will take you through a step by step process.

Once EZ Learning Mode is selected, it must be scrolled through from start to finish before it will exit EZ Learning Mode. You can also exit EZ Learning by disconnecting power from the probe and the probe will enter normal test mode when re-connected. NOTE: If you see a flashing screen in the menu, it means go to that selection and press enter.

This mode is to be used for familiarization and guidance only, and is not a mode used for actual circuit diagnosis.



INTRODUCTION TO GUIDED DIAGNOSTICS

Guided Diagnostics Mode will help guide you through specific vehicle or components test and let you know if readings obtained are acceptable to outside of the normal readings.

From the Main Menu, click on The Guided Diagnostics icon. With Guided Diagnostics, you can have a better understanding of the basic testing steps in electrical diagnosis. This will help you diagnose most basic electrical problems starting with the most fundamental issues.

The results provided will inform you of the state of the vehicle with OK, LOW, HIGH or CHECK.

Tests available in order are:

BATTERY TEST - Provides feedback on battery state of charge

CHARGE TEST - Provides a test for Alternator Charge state and ripple

FUSE TEST - Gives a straight forward answer on fuse condition

COMPONENT CHECK - Suggests best practices

WIRE TEST - Gives you feedback on the health of the wiring system

It should be noted that the tests are a guide to best practices for general Automotive Electrical diagnosis but do not constitute a complete diagnosis and do not guarantee issues are good or bad. Knowledge of general diagnosis is required.

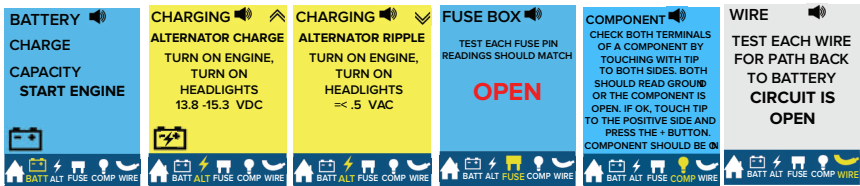

START-UP

Operation Source Voltage

The *Maestro*[™] is designed to connect to and is powered by 12 to 24 VDC electrical systems. It comes supplied with a 23 ft. heavy duty power cable and a Y-connector with 2 battery clips.

Connecting To The Vehicle's Battery (Voltage Source)

Connect the red clip to the positive terminal of the vehicle's battery source and the black clip to the negative or ground terminal. The *Maestro*[™] start-up tone will sound.

Auxiliary Ground Lead

The auxiliary ground lead provides ground to circuits and components that are not already connected to ground. It also serves as the negative lead for resistance testing. To test the auxiliary ground lead, contact the probe tip and the auxiliary ground lead together. The Green LED should illuminate. This shows that the auxiliary ground lead is working properly. If the green LED does not illuminate, check the replaceable 20 amp fuse in the auxiliary ground lead. The fuse is for protection in the event the ground lead inadvertently contacts the positive voltage.

LED Flashlight

Flashlight is a standard feature on the *Maestro*[™]. The two bright white LEDs are always ON making it possible to see under dashboards and in dark areas.

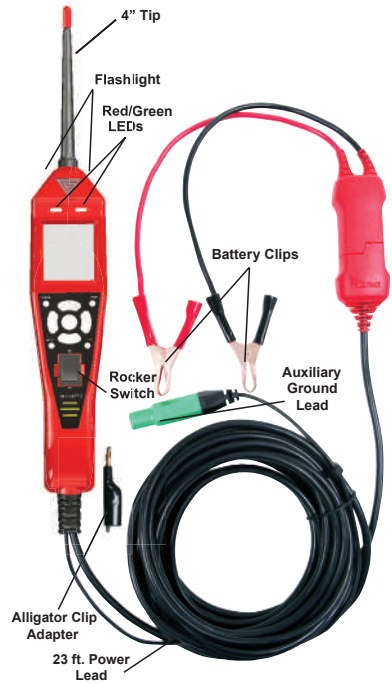

MAIN MENU

The *Maestro*[™] provides a more updated user interface and combines it with an App that expands the tools capability and access to knowledge.

To access the features of this tool, there are new buttons provided that are intuitive and simple to understand. All buttons only have one function marked, no extended pressing or double pressing is required. You will find the most used features such as Clear, Mute, Flip, and Pair all have a readily accessible button to keep you from scrolling to find them.

Another feature is all menu options for any given mode are present on the screen at all times. If you are on the Main Menu, you will find all the options on one screen. The Up, Down, Left, and Right buttons do just that.

When in Multi Meter Mode or Guided Diagnostics, all possible selections are present without jumping in and out of the menu.

We have made this the easiest and most intuitive Power Probe yet and the first of our Pro Series Line which provides expanded features with a connected App for both Android and iPhone users.

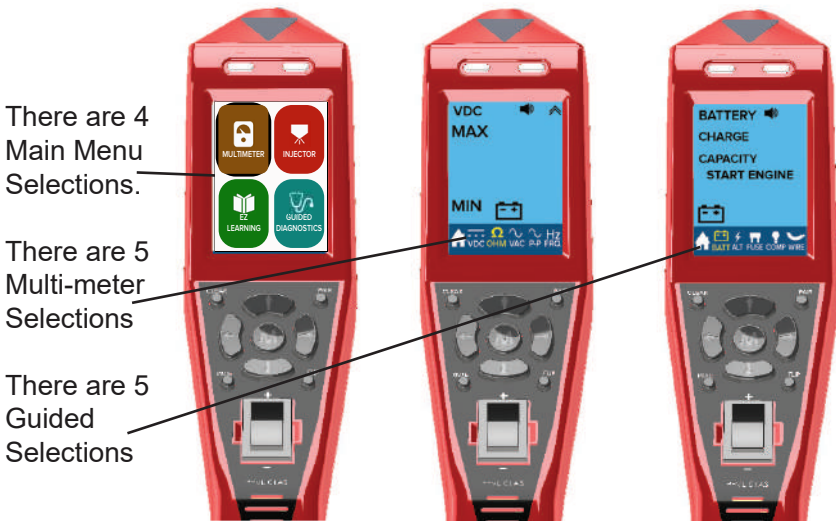

MODE NAVIGATION

The *Maestro*[™] has 5 different test modes available inside Multi Meter Mode and 1 stand alone mode:

- 1. VDC** - For DC voltage measurements. This is the default mode on startup. Max. 200 VDC
- 2. OHM** - For resistance readings. All readings are current loaded so wire issues will cause readings to appear different than other meters. Inside Ohm Mode is:
FEED TEST - For displaying voltage drops caused by wiring issues on feed and ground circuits.
- 3. AC RMS** - For AC voltage measurements. Displays an RMS averaged AC voltage. Max 200 VAC.
- 4. P-P** - For AC voltage measurements. Displays Peak to Peak AC voltage. Max 200 VAC.
- 5. Hz FRQ CTR** - For measuring signal Frequency. Also displays + and - Pulse Width.
- 6. FUEL INJ** - Test Fuel Injectors and Injector circuits *outside Multi Meter mode.



Press the "Right Arrow" button



Scroll to the Mode
The icon will highlight
You can press "Left Arrow" to go back



Press the "MODE" button to select



DC VOLTAGE MEASUREMENT IN VDC MODE



In this mode, you will supply battery power or battery ground to the tip when pressing the rocker switch



VDC - VDC mode is for testing DC (direct current) voltages. Voltage testing is as easy as contacting the probe tip to a circuit and reading the display. The *Maestro*[™] will display the probe tip voltage in the center display.

The *Maestro*[™] automatically enters VDC Mode when first connected to the vehicle's battery, or to a 12-24 volt power supply. VDC Mode is the only mode that the Power Probe can supply battery power or ground by pressing the rocker switch.

If the probe tip voltage is within 0.5 volts of the source battery voltage, the Red LED will illuminate and if the speaker is turned on, the speaker will emit a high-tone.

When testing on ground circuits, as long as there is less than 10 Ohms total circuit resistance from tip to battery ground voltage and is .5V or less, the Green LED will illuminate and the speaker will emit a low-tone.

This greatly simplifies testing as the *Maestro*[™] Red/Green LEDs and speaker tones provide a quick indication if there are excessive voltage drops or circuit resistance. If the LEDs do not illuminate and there is no tone from the speaker, you know instantly there may be a circuit problem.

Minimum and Maximum (MIN/MAX) voltages are shown on the top and bottom left of the display. To reset the MIX/MAX, press the left "CLEAR" button beneath the display.

VDC Mode has a very high sampling rate that is good for tests where the tech is looking for glitches or deviations from the main signal. This is a very sensitive mode that can capture even the smallest voltage spikes or drop-outs without having to use a scope.

The *Maestro*[™] can safely measure up to 200 VDC.



ACTIVATING COMPONENTS IN VDC MODE



Activating Electrical Components in VDC Mode is one of the main features that makes the *Maestro*™ very useful in testing. Being able to apply battery power or ground right to the probe tip gives you the ability to activate and dynamically test electrical components such as lights, motors, and solenoids.

You can power up components on the vehicle or on the bench by utilizing the auxiliary ground lead. This type of dynamic component testing is the only true method to verify a components correct operation. Testing a part with a volt-ohmmeter may tell you if the part is out of spec, but you never really know if the part is good until it is operating under power.

Pressing the rocker switch forward supplies battery power to the probe tip.

Pressing the rocker switch rearward supplies battery ground to the probe tip.

The power output is circuit breaker protected. If the component being tested draws too much current, or the circuit has a shorted condition, the *Maestro*™ circuit breaker will trip protecting the tool and the circuit.

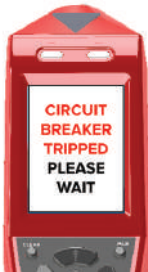

When the circuit breaker is tripped, the unit display will show “CIRCUIT BREAKER TRIPPED” and will automatically reset itself after a 10-20 seconds.



Pressing the rocker switch in any other mode will not apply power or ground and the main screen will display this message.



RESISTANCE TESTING IN OHMMETER

OHMMETER is used to check resistance on static circuits or voltage by simply probing the connection of the circuit being tested.

OHMMETER is used like a standard Ohmmeter and measures total circuit resistance from the source battery accurately with the Aux. Ground lead whether there is voltage feeds on the circuit or not. In this mode, the *Maestro™* display will show:

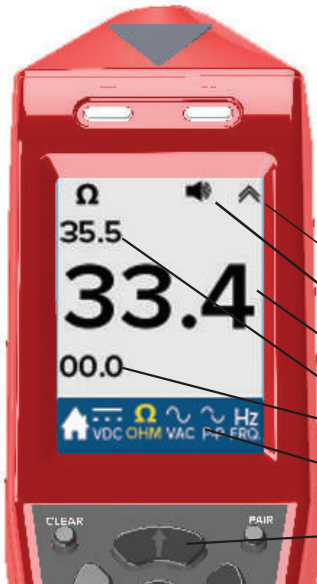

- ① This arrow indicates the up arrow can be pressed for special function
- ② Speaker is on
- ③ Total circuit resistance on the center screen
- ④ Max and Min resistance
- ⑤ Multi Meter selection
- ⑥ If #1 arrow is pointing up, pressing the up arrow will access special function

The circuit resistance will be calculated even with voltage applied to the circuit. To accurately test the power and ground feed resistance, the component must be removed from the circuit first. Simply unplug any component, relay or module on the circuit, contact the probe tip to the circuit and view the circuit resistance.

Maestro™ has a feature located in some modes that show an arrow in the upper right corner of the screen. If this arrow is present, pressing either the up or down arrow as indicated by the state of the arrow will take you to special functions or back to the main screen. In Ohmmeter, pressing the up arrow will take you to the Feed Test.



POWER FEED TESTING

⚡ **FEED TEST** - Power Feed Test is used to identify voltage drops on active circuits by probing one connection of the circuit being tested.

PFT displays both Battery and Tip voltage simultaneously for easy voltage drop testing. While testing, use the Aux. Ground and tip to by-pass components. Place meter in line in place of component and operate switches or relays to close circuit.

In this mode, the *Maestro™* display will show:



- ① Down Arrow Indicates pressing the Down Arrow will return to Ohm Meter
- ② Probe Tip Voltage.
- ③ Battery Voltage.
- ④ Ohm symbol displays and flashes if .5V drop is exceeded showing that excessive resistance may be present as corrosion or other wire damage.



OHM TESTING AND POWER FEED

To test, first disconnect the device or load being operated from the circuit, then contact the probe tip to the circuit being tested. Disconnecting the component from the circuits prevents it from affecting and altering the resistance reading.

Ohmmeter can also be used on wires or components not connected to battery power or ground. Simply connect the item being tested between the probe tip and the auxiliary ground lead and read the resistance reading in Ohms.

While it is possible to ohm check some components, it should be noted that Ohmmeter and PFT are primarily for use on wiring only and should never be connected to a solid state component such as a module.

In Feed Test, you will see the LED's light if the circuit is within the LED limits and if they do not, you can see the actual voltage drop on the display.

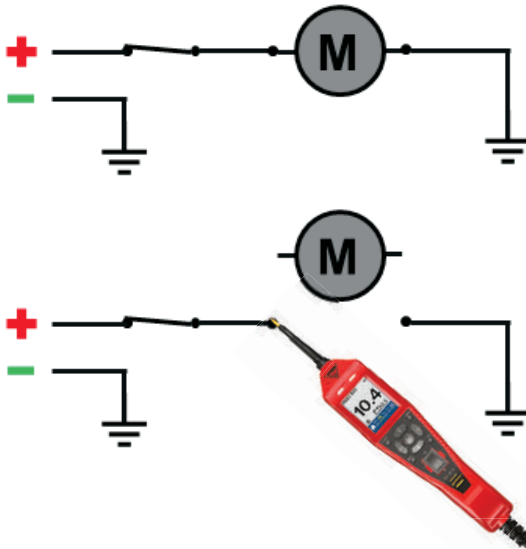

AC VOLTAGE MEASUREMENT (RMS)



~ AC RMS Mode is for measuring AC (alternating current) voltages and can be used on any AC voltage or pulsed waveform signal where an RMS average voltage measurement is required.

Contact the probe tip to the circuit and it will display an RMS averaged AC voltage reading in the main display area while also displaying RMS Min/Max AC voltages on the top and bottom left of the display.

Powering up and activating circuits with the rocker switch can not be performed in this mode.

Pressing the “CLEAR” button will reset Min/Max readings.

AC RMS Voltage is used in the same manner as a standard DVOM would be used to measure the averaged AC voltage in any circuit that produces AC voltage. This can be used for, but not limited to, tests such as checking alternator diode ripple, abs sensors, crank sensors, etc.

WARNING: Do not use the *Maestro*™ to test AC line voltage such as 120V wall plug. This will damage the probe and could cause personal injury. Vehicle use only.



AC VOLTAGE MEASUREMENT (P-P)



 P-P Mode can be used on any AC voltage signal where a Peak to Peak (P-P) voltage measurement is required.

P-P stands for Peak to Peak AC voltage. Where AC RMS displays an average AC voltage, P-P does not average the reading but displays the total voltage difference from the lowest to highest voltage extreme on an AC signal.

In this mode, the display will be an AC Voltmeter that shows the peak voltage difference in the center and the Min/Max voltage readings along the top and bottom left of the display.

The voltage displayed is the total voltage potential between the lowest and highest voltage sensed on the AC signal being measured.

The total Peak to Peak voltage will be shown in the main display area. The Min voltage will display lowest absolute voltage on the bottom left of the display and the Max voltage will display the highest absolute voltage on the top left of the display.

Powering up and activating circuits with the rocker switch can not be performed in this mode.

Pressing the “CLEAR” button will reset Min/Max values.

This can be a more accurate test for signal circuits such as sensors or data communication lines where measuring the full range of the AC signal is required.

The *Maestro*[™] can measure P-P Ac voltage from -100V to +200V.



FREQUENCY MEASUREMENT



FRQ CTR - Frequency Counter mode is used for measuring the frequency of an alternating voltage signal.

Contact the probe tip to the circuit and it will display the frequency in Hertz (cycles per second) and Duty Cycle on the top and also displaying the + Pulse Width and - Pulse Width in milliseconds on the bottom.

The *Maestro*[™] can measure frequencies from 1Hz to 9999Hz.

FRQ CTR can be used for tests where frequency or pulse width are needed such as MAF sensors, wheel sensors, etc.



TRACE MODE

The *Maestro*[™] has a new feature called Trace Mode. In Trace Mode, you can view the data as a wave form. Trace Mode can be found in VDC, VAC, Frequency, and Injector Modes. Each mode displays relevant information tailored for automotive testing.

To enter Trace Mode, first enter into 1 of the 4 modes: VDC, VAC, Frequency, or Injector. At the top right of the screen, the double arrows indicate you can press the Up Button to change modes. Pressing the Up Button will change to Trace Mode.

NOTE: When in Trace Mode, the double arrows are pointing down indicating to press the down button to go back. Pressing the left or right buttons in trace mode will take you into the meter indicated but will enter as standard mode.

Trace Mode in VDC

MAX reading will collect and hold the highest measured reading until clear is pressed.

Average voltage on the tip

MIN reading will collect and hold the lowest measured reading until clear is pressed.

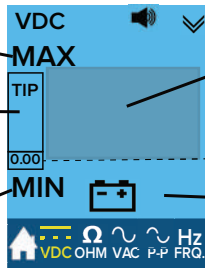

Down arrow indicates pressing the down button to exit trace

Active Trace Area (ATA)
(Area highlighted here for clarity)

Ground Reference line

Battery Voltage

In VDC Mode, Min/Max, and average tip voltage are always displayed on the left screen. The linear trace reading will display in the field highlighted active trace area. VDC will typically be displayed as a flat line. The *Maestro*[™] can read up to 200V so ranging will cause the highest value to be displayed at the top of the active trace area while auto zooming in and out.



TRACE MODE (CONT.)

For instance, if 12V is on the tip with no fluctuation, it will display as a straight line at the top of the active trace area (ATA). If 50V is on the tip, it will also display at the top of the ATA as a flat line. You will see that the voltage value of the trace is displayed under TIP. If 12V is on the tip and the trace is at the top of the ATA and a glitch occurs that increases the voltage temporarily to 50V, the trace will quickly zoom out. You will see the trace will temporarily reflect a single peak with highest point at the top of the ATA and the original 12V flat line will be respectively closer to the Ground Reference line. The screen updates every 300mS so if there are no more glitches, the line will return to the top of the ATA as it zooms back out in 300mS. You will notice the Max reading will hold at 50V until a new higher Max is detected or it is reset by pressing the clear button. If multiple glitches are occurring, it will always zoom out with the highest peak showing at the top of the ATA and any other peaks showing within the field respective to their voltage.

MAX reading will collect and hold the highest measured reading until clear is pressed.

Average voltage on the tip

MIN reading will collect and hold the lowest measured reading until clear is pressed.

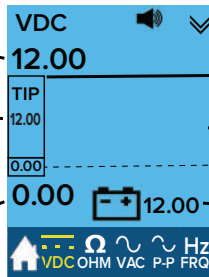

Indicates pressing the down button to exit trace mode
 Live Trace reflecting steady average tip voltage
 ATA
 Ground Reference line
 Battery Voltage

MAX reading will collect and hold the highest measured reading until clear is pressed.

Average voltage on the tip

MIN reading will collect and hold the lowest measured reading until clear is pressed.

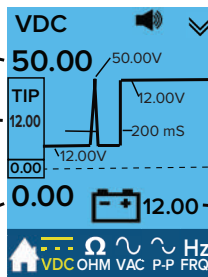

Indicates pressing the down button to exit trace mode
 Live Trace reflecting 50V glitch then returning to 12V after 300mS
 ATA
 Ground Reference line
 Battery Voltage



TRACE MODE (CONT.)

Trace Mode In VAC

VAC Trace Mode works differently. VAC Trace Mode will provide the same information as in normal AC Mode while viewing the signal including the average RMS AC and the highest RMS AC and lowest RMS AC both captured in the MIN and MAX. MIN and MAX can both be reset.

Trace Mode in FRQ CTR

FRQ CTR Trace Mode shows a constantly updating MIN and MAX that gives you the value of the highest and lowest peak voltage. Every 200ms a new MIN or MAX will be captured and displayed in the boxes next to the dotted lines. The dotted lines become the value noted in the boxes. The ATA will zoom in and out depending on amplitude of the signal so the wave form will always be bounded by the dotted lines. The Peak to Peak value will display in the center box instead of RMS AC.

Trace Mode in INJ

In INJ Mode, you will see the injector wave form, the MAX peak voltage and the relationship to Ground. The MAX peak in the top box will refresh with every pulse.

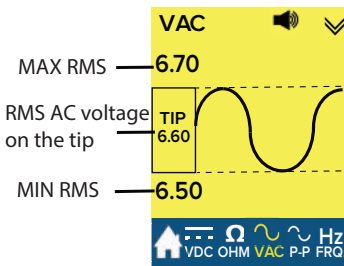

MAX signal amplitude will update every 200ms.

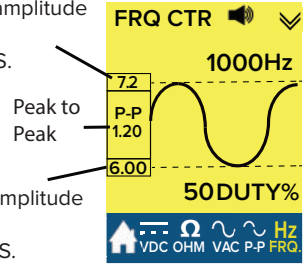

Peak to Peak

MIN signal amplitude will update every 200ms.

MAX reading will change with every pulse

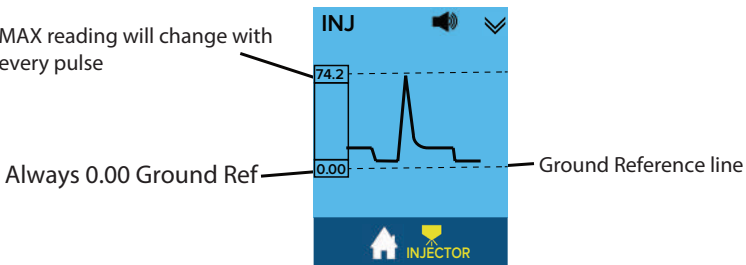

Always 0.00 Ground Ref

Ground Reference line



FUEL INJECTOR MODE

 FUEL INJ - Fuel Injector Mode is specifically set up for fast and easy injector circuit diagnosis. One quick connection to the circuit and the *Maestro*[™] will display all the needed fuel injector testing information that would normally require using a lab-scope.

Below is an example of a typical fuel injector voltage waveform on a lab scope. This is displaying a single injector pulse. The vertical axis represents circuit voltage and the horizontal axis represents time.

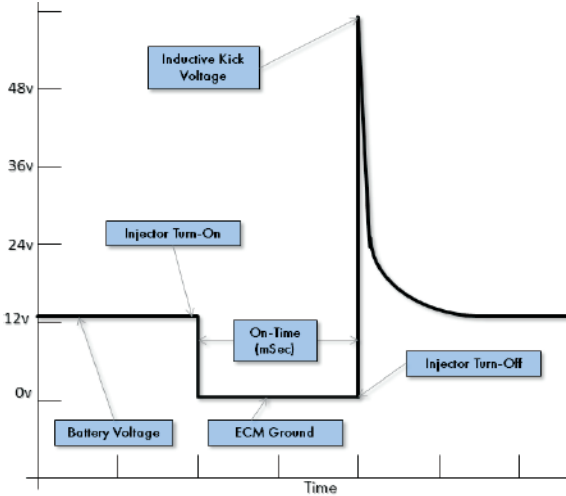

Following the waveform from left to right, you can see the circuit voltage near battery voltage until the injector is turned on. This is the Injector Supply Voltage.

Then the voltage will drop to near zero when the ECM/PCM switches to ground or ECM Ground voltage.

The windings inside of a fuel injector produce a magnetic field when the injector is energized. Each time an injector is turned off, this magnetic field collapses back into the injector windings and induces a hi-voltage spike. The voltage spike is the Inductive Kick Voltage.

The time between when the injector is turned on to when the injector is turned off is simply called the Injector On-Time and is usually expressed in milliseconds. The *Maestro*[™] displays each of these four data points on one screen giving a complete picture of the electrical performance of the injector and the entire injector circuit.

The Red/Green LEDs above the LCD display will blink and are synchronized with the injector signal from the ECM with a corresponding tone from the speaker out. These audible and visual cues can quickly identify any intermittent loss of signal from the ECM.



FUEL INJECTOR MODE



- Select INJECTOR from the Menu.
- Back-probe on the negative side of the injector either at the injector or at the PCM.
- These four data points represent the corresponding waveform points.
- When the engine is running (or cranking) the tool's red and green indicator LEDs will blink to indicate a good signal from the ECM/PCM.
- The main screen will display complete injector circuit data for quick comprehensive injector circuit diagnoses.

① ON ms = **Injector Pulse On Time (milliseconds)** - This is the total amount of time that the fuel injector is energized and supplying fuel to the cylinder. This can be compared to scan tool PID data to see if commanded on-time equals actual on-time.

② IND-KV = **Inductive Kick Voltage** - Normal inductive kicks range between 55 and 90 volts. You should see a similar voltage number from each of the injectors on the engine. NOTE: The height of the inductive kick is sometimes cut-off by an internal ECM diode to about 35-45 volts. This test does not apply to hi-pressure injectors used on diesel engines and gasoline direct-injection engines.

③ ECM V = **ECM Ground Voltage** - The engine computer activates each fuel injector by completing the ground circuit with an internal transistor switch. When the fuel injector is energized, the ECM ground voltage should be close to zero volts. Actual measured ECM ground voltage can vary, and may be closer to 0.5 volts because of the internal resistance of the switching transistor.

④ INJ V = **Injector Supply Voltage** - This is the battery power being supplied through the fuel injector itself. Measured voltage should be close to fully battery voltage. There may be small voltage drops in the circuit, however, anything more than 0.5 volt loss from the source battery voltage should be investigated.



THE PRO SERIES APP

The *Maestro*[™] has a new feature designed to help the mechanic in the shop by providing resources and additional diagnostic functions.

The Pro Series app is a diagnostic app developed for both iOS and Android that can quickly provide you with up to date problem solving information and news, unique special tool applets and the ability to log, i.e., replay and share diagnostic data occurring on the tip.

This new App will be updated with new information, tool applets, additional features and will adapt to future Power Probe TEK tools that will allow you to build transferable files on vehicles to be accessed at a later time. You will be able to search, cut and splice traces and log data to identify occurrences that you might have missed, to study and share.

Mirror Function

The app has a mirror function that allows what you see on the tool screen to be mirrored. See “Pairing PG. 27” to connect. When mirroring, you will have a larger screen to help view the data.



THE PRO SERIES APP

Pro App features are:

- Clear Max and Min individually
- Press the capture button in standard view to capture the data on the screen. It will be saved as a voltage value.
- Pro App will save and buffer up to 1GB of collected data. After conducting a test, you can scroll back through the data to a specific occurrence. Once located, you can splice the trace to be a screenshot or play as a video. You can then purge any unwanted data and save your capture to be replayed or even email Power Probe TEK technicians to help you with your diagnosis.
- Data Log will start recording when pressed. As long as it is pressed the data will continue to collect. You can view it back in log or trace form or splice and save your data as required.
- When using guided diagnostics, you can collect and save results as well as take images of issues that you want to capture and tie to a specific vehicle. On the tool, you will have information that helps you decide if something is normal or not. The app will save that data for future reference in a special log along with pictures of damage or other points you may want to share later.

When you plug into the Pro Series App, you are plugging into the future of automotive diagnostics. Visit iTunes or Google Play to download the Power Probe TEK Pro Series App for free and begin getting more out of your Power Probe TEK Tools.



PAIRING

The Pro Series app will need to be paired with your *Maestro*[™]. With the tool powered on, open your Pro Series App.

You will see a selection to Pair Device. This will work with all Power Probe Tek Tools that use the wireless communication.

Press the Pair button on the app, it will prompt you to begin the pairing process. There is a button on the tool labeled “Pair”. When prompted by the app, push the button and your tool will pair with the app.

To use the tool within the app, simply select a mode on the *Maestro*[™] and it will populate on the screen. Changing modes on the tool will be tracked by the app and change with it.

When finished, be sure to save your data!



ROCKER SWITCH REPLACEMENT

The *Maestro*[™] Rocker Switch is used constantly and arcing can occur across the switch contacts and eventually the switch can wear out.

The *Maestro*[™] also has an Automatic Resetting 8 Amp Thermal Circuit Breaker and like the Rocker Switch, the Circuit Breaker can also wear out over time. If this occurs, the Rocker Switch and Circuit Breaker are made to be easily field replaceable.

Replacement Rocker Switches (Part # PPTK0021) and Circuit Breakers (Part # PPTK0030) can be purchased from your tool dealer or from Power Probe direct.

Follow the instructions below to replace a worn Rocker Switch:

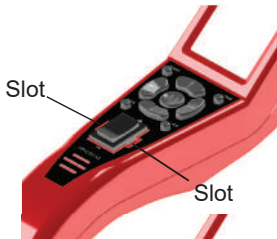

Locate the two slots on either side of the Rocker Switch



Carefully remove the Rocker Switch with an appropriate pry tool or small screwdriver. Do not apply excessive force.



Position the new Rocker Switch into the switch cavity and carefully press straight down until the switch is flush with the housing



PRODUCT SPECIFICATIONS

Min Operating Voltage	9 VDC
Max Operating Voltage	30 VDC
Max Tip Voltage	450 Volts
Probe Tip Resistance to Ground	350 K Ohms
Computer Safe	0.1mA floating tip
Voltage Measurement	-100 to 200 VDC/VAC
Voltage Resolution	-99.99 to 99.9 V - 0.01V (10mV)
Glitch Capture	>380 μ S Min Pulse Width
Power Feed Test	< 30 mA
Resistance Measurement	0.01 Ohms to 10K Ohms
Frequency Measurement	1Hz to 9999Hz
Fuel Injector Mode	LED Flash @ Min 35V @ 100 μ S Pulse
Red LED Response	Within 0.5V BATT V in Voltmeter Mode and >10 Ohms in Power Feed Test Mode
Green LED Response	< 10 Ohms in both Power Feed Test Mode and Voltmeter Mode and <.5V in Voltmeter Mode
Circuit Breaker	8 Amp Thermal – Auto Reset
Breaker Trip Response	8 Amps = No Trip 10 Amps = 20 min. 15 Amps = 6 sec. 25 Amps = 2 sec. Short Circuit = 0.3 sec.
Operating Temperature	-20°C (-4°F) to 50°C (122°F)
Storage Temperature	-40°C (-40°F) to 65°C (149°F)
Storage Humidity	5% to 95% RH with 33C max dew point. (Non-condensing)
Operating	10% - 80% RH with 29C max dew point (Non-condensing)
Altitude Operating	3048M Max
Altitude Storage	12000M Max
Indoor/Outdoor Usage	IP54 dust and water resistant