

**2001-2005
GM 6.6L Duramax
Main Stud Kit**

(118034000)

Installation Guide

ATTENTION: We recommend the installation of this part be done by a trained professional GM technician. PPE will not accept liability for damage resulting from incorrect assembly.

These instructions are not intended as a service or overhaul manual. These instructions are intended to facilitate the modification of non-factory parts installation by a trained professional.

NOTE: Tolerances will change when changing from factory to high-strength fasteners. It will be necessary to check main bearing bores for proper size and out-of-round condition after installation of the studs. Hone the cylinder block if necessary. Main bores should always be align-honed using the same fasteners and lubricant which will be installed, at the recommended preload, during the final engine assembly.

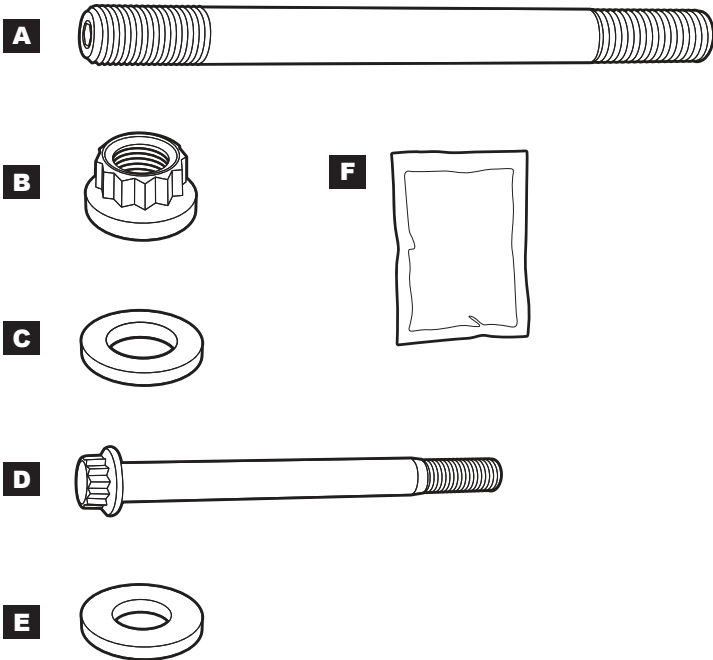

CONTENTS

- A: M14 Studs (10)
- B: M12 Flange Nuts (10)
- C: Flat Washers (10)
- D: M12 Cross Bolts (10)
- E: Flat Washers (10)
- F: 1-oz. Fastener Assembly Lubricant (1)

Inspect for damage or defects and clean all hardware prior to installation. Verify product part number matches your application.

NOTE:

Loctite may be used for permanent mounting. Torque sequences must be complete prior to Loctite hardening.

Clean all threads in the engine block. Use a Bottoming Thread Chaser if necessary, to ensure thread engagement, and more accurate torque readings.

Install M14 Studs (A) into the block and hand-tighten without tools (equivalent of 20-30 in. lbs.). Install main caps and check for proper alignment.

Lubricate M14 Stud (A) threads, M12 Flange Nuts (B) and Flat Washers (C) with the Fastener Assembly Lubricant (F) provided. Install the washers and nuts onto the studs.

Tighten nuts in three equal steps using the torque sequence to a total spec:
M14 studs = 175 ft lbs

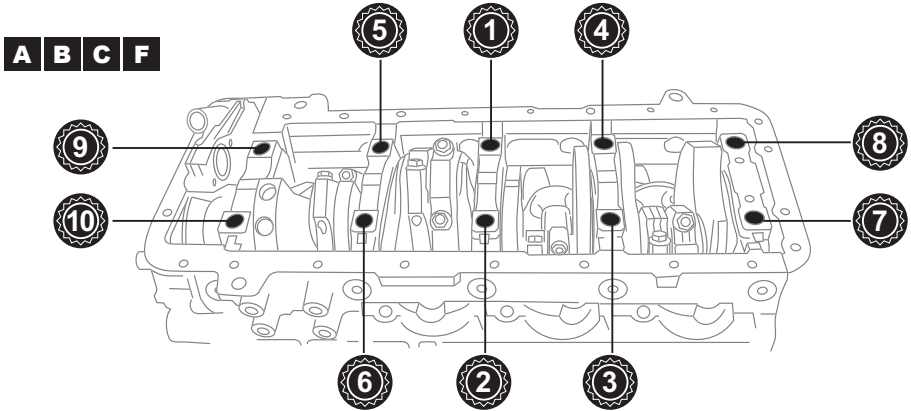

Lubricate Flat Washers (E) and M12 Cross Bolt (D) threads with Lubricant (F). Install Flat Washers (E) on to M12 Cross Bolts (D). Thread assembly into the block. Tighten M12 Cross Bolts to torque spec = 90 ft lbs.

