

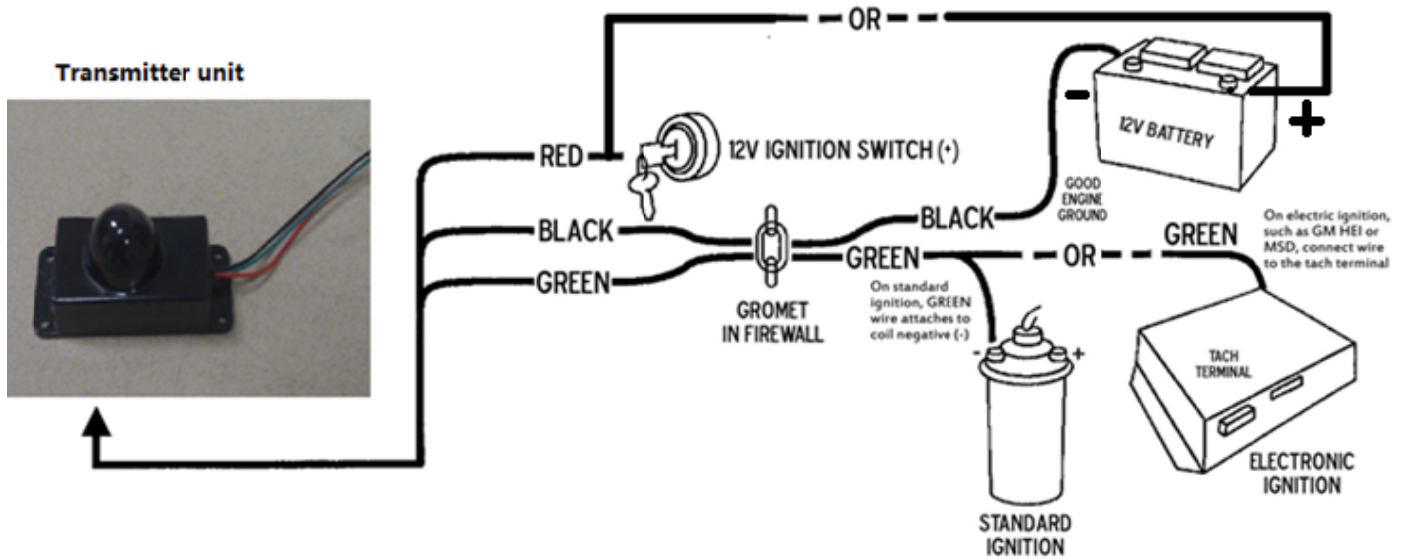

- * BEFORE YOU START
- * Always Wear Safety Glasses!
- * Use Extra Caution when Working With Electrical Components

Wireless Mini Digital Shift Light & Diagnostic Tachometer

Part no: 67006C



Receiver display unit



----- Mounting -----

The transmitter unit is designed to be installed inside the engine compartment and tied securely using nylon zip tie. The versatile shift light receiver display base design permits many mounting possibilities, using ordinary machine screws. In some cases mounting with a hose clamp, or a basic 2 sided adhesive may be preferred. The mounting base connects into three different positions on the shift light, which allows the light to be adjusted forward or backward depending on external clearance issues that may be present. To remove the mounting base, simply slide it toward the rear of the shift light.

----- Troubleshooting -----

Proper shift light operation requires a good ground and securely connected wiring. If you are having trouble, double---check your ground and be certain that you have 12 volt power. Be sure you have followed the wiring diagram instructions above. We recommend you avoid crimp connectors and solder all connections if possible. Soldering your connections will minimize any loose connections that may cause problems.

Wireless Mini Digital Shift Light & Diagnostic Tachometer Operating Instructions (part no. 67006C)

Product Overview:

The wireless Mini Shift Light & Diagnostic Tachometer is designed for regular use as a shift light, and tachometer use when working under the hood. The tachometer functionality is not intended for use when driving the vehicle.

The main features include:

- Shift light with 3 bright amber colored LED lights
- 1 thru 12 cylinder functionality
- 100---12,000 RPM range
- Adjustable display brightness
- Display on/off mode

The transmitter unit's easy-to-connect 3-wire hook up is intended to make installation fast and easy for most engines. Please note that some late model vehicles that do not use ignition distributors may need a tach adapter (not included).

Installation:

1. Install the transmitter unit and connect the wires as depicted in the wiring diagram.
2. Use zip ties or tape to wrap the wires in an organized way before operating.
3. Mount the receiver shift light display unit with screws, adhesive, or hose clamps to a desirable location within the cockpit of the vehicle so the lighted end is within the driver's forward line of sight. Please note: it may be easier to install if the light is disconnected from the mounting base.

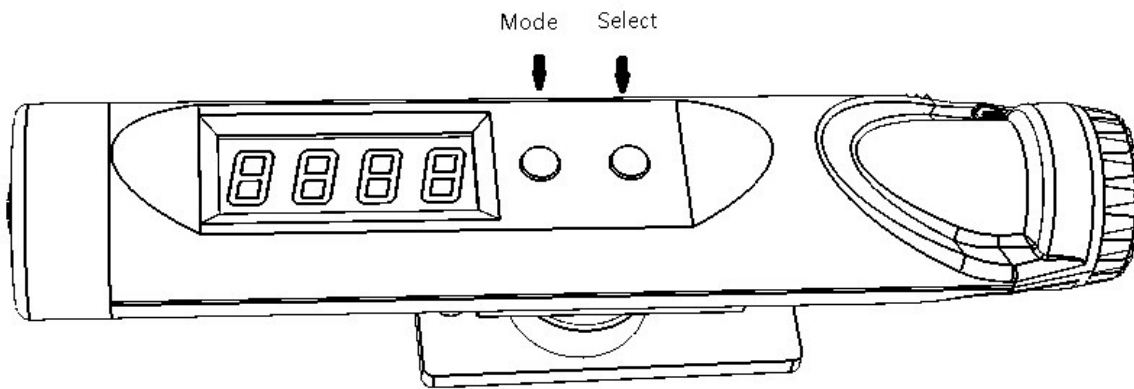

Operation:

1. **Battery installation:** Unscrew the circular battery cover off the rear of the shift light, and insert 4 LR44 (303) or SR44 (357) batteries into the cavity. Be careful of the orientation of the battery must be the same as the indication on the case. Screw the battery cover back on to the unit.

2. Switch on the small on/off switch at the rear part of the shift light. The shift light display should show ---0 if the transmitter unit is not powered up.
3. Setting the number of **Cylinders**
 - a. Press and release the **Mode** button until the display reads **CY**.
 - b. Press and release the **Set** button until the correct number of cylinders is shown next to CY.
 - c. Press and release the **Mode** button once to set the number of cylinders
4. Setting the **RPM** shift point
 - a. Press and release the **Mode** button until the display reads **A**.
 - b. Press and release the **Set** button to set the RPM shift point (Units are x100 RPM's, e.g. 52 = 5,200 RPM's).
 - c. Press and release the **Mode** button once to set the RPM value.
5. Setting the display **Intensity**
 - a. Press and release the **Mode** button until the display reads **I**.
 - b. Press and release the **Set** button for brightness values that range from 0 to 7.
 - c. Press and release the **Mode** button once to set the display intensity.
6. Setting the display **On/Off** when in use
 - a. Press and release the **Mode** button until the display reads **IED**.
 - b. Press and release the **Set** button to 0 or 1. Select 0 to turn the RPM display off when in use. Select 1 for the RPM display to be on at all times.
 - c. Press and release the **Mode** button once to set the On/Off.

Once the initial setup is complete the RPM values will be shown on the display when the vehicle is running. The shift light will remain on when the shift point is exceeded, and turn off when the RPM's fall below that point. Switch off the shift light when not in use.