



Installation Tips: Bleeding the System

1. The vehicle's battery should always be disconnected before any modifications are made.
2. Make sure all of the fittings in the power steering system are tight.
3. Raise all steering tires off of the ground.
4. Fill reservoir with power steering fluid (NEVER use automatic transmission fluid). Leave the cap off of the reservoir.
5. Cycle the steering from lock to lock three or four times.
6. Check fluid level in reservoir. Refill as needed.
7. Repeat steps 5 and 6 until a consistent level in the reservoir is reached.
8. Reconnect the battery. Replace the cap on the reservoir.
9. Start the vehicle and let it run without any steering input for 30 seconds.
10. Turn off engine.
11. Check and refill reservoir as needed, replacing cap when done.
12. Start engine and cycle steering from lock to lock 10-15 times.
13. Turn off the engine and let it stand for 10 minutes to allow air bubbles to work out of the system.
14. Repeat steps 11-14 until there are no air bubbles visible in the reservoir.
15. With the engine running, observe the fluid level in the reservoir. While looking in the reservoir, turn off the engine. The fluid level should not change.
16. If the level does not change, check the system for leaks. If there are no leaks, test drive the vehicle. If the level does change start over at step 4.



Installation Tips

Reservoir Placement

Reservoir placement is the most likely cause of many power steering woes. The pump works remarkably well at pushing fluid out but not so great at pulling it in. Since the pump is fed by the reservoir mainly through gravity, reservoir placement is critical. Things like vehicle position and attitude while driving must be considered when mounting the reservoir. Generally, the higher the reservoir the greater the chance of having a trouble free system. But, there is more to it than just the height. For example, a reservoir mounted high on the firewall will work fine most of the time, but when making a steep climb the pump is likely to starve. Also, the feed line between reservoir and pump should be as short as possible. The greater the distance between the pump and reservoir, the more work the pump has to do bringing the fluid in and the greater the effect of vehicle attitude on the system.

Air in the fluid can wreak havoc on a power steering system. Since the air can compress, whereas the steering fluid does not, much of the force from the pump can be absorbed by the air instead of being properly transferred to the steering box or cylinder. In addition, air can lead to pump destruction. Air causes cavitation in the pump which will greatly increase wear and dramatically shorten the life and performance of the pump.



An example of the proper way to mount a reservoir

Reservoir Installation Checklist:

1. Keeping in mind the pump is gravity fed, the reservoir should be the highest point in the power steering system. This will help ensure the pump gets all the fluid it needs as easily as possible, greatly extending the life and performance of the pump. If the reservoir is too low some components may drain back into the reservoir upon engine is shut off. This can cause leaking or, worse, allow air into the system. Another problem with a reservoir mounted low is that the pump will be working overtime, all the time.
2. It is preferable to mount the reservoir directly over the pump. If this is not possible, in front of the pump is typically better than behind it.
3. If the reservoir must mount to the frame, body, etc (anywhere not directly tied to the engine) take special care that the feed line will not become stressed during engine torque over or other twisting and flexing maneuvers.
4. Use a baffled reservoir. A properly baffled reservoir will help keep air out of the system. A non-baffled, or poorly baffled reservoir can introduce air simply by allowing air to mix with the fluid as it enters the reservoir.
5. The feed line should be kept as short and straight as possible. It should

not have any dips or sharp bends and should never run below the level of the pump. The feed line should never be crimped, looped, or run horizontal – it should always be flowing downhill into the pump, the steeper the better. The longer the feed line, the harder it is for the pump to draw fluid in. It should not exceed 16 inches. The feed line should also be of sufficient size to meet the demands of the pump, #10 is the recommended minimum. Do not use the supplied -6 pressure line as the feed line, use the -10 feed line. When attaching the feed line to the pump, do not over tighten! The wrench used is typically long providing a great deal of leverage, it is not uncommon to see these fittings twisted off.

6. The reservoir should be vented, and this vent must remain open. The reservoir cap can be drilled and tapped to accept a 90 degree fitting if this helps with clearance issues. If the vent is spitting fluid, it is a sure sign that air is in the system and needs to be bled.

7. Do not bend any fittings. Example: bending a 90 into a 120. This will result in restricted flow.

8. The reservoir should be filled to 1" below the top of the reservoir (see illustration). On single ended cylinder applications this should be measured with the cylinder collapsed.

The following are examples of what NOT to do.



In this example the feed line is quite short which is a big plus. But, the fact that it is running horizontally negates any benefit.



This image shows multiple violations. It is obvious that the feed line is entirely too long. The slope of the feed line is not great enough. It appears to run flat in some places and even runs uphill in others.



Here the feed line is kinked, cutting off flow to the pump.



This picture shows another hose that has collapsed from using a bend that is too tight. It also shows a big dip in the hose which will cause pump starvation.



Here the feed line starts out just above the center line of the pump and must go uphill to meet the inlet of the pump.



In addition to a loop, this picture illustrates a bend that is too tight resulting in a collapsed hose.

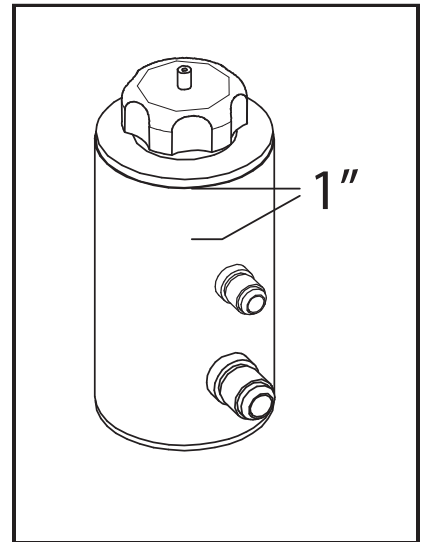

Fill Level should be 1" below the top of the reservoir. On single ended cylinder applications this should be measured with the cylinder collapsed. Your reservoir may differ from that pictured here.



Installation Tips: Steering Cylinder Assist

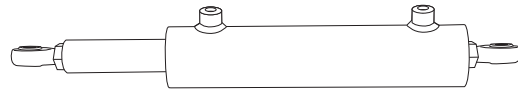

When installing any cylinder it is important to ensure that the rod ends or clevises are mounted in the same plane. This plane should be that which the steering arms create as they move. They should be installed flat (horizontal). This will allow the greatest range of motion and help ensure that no binding occurs. The cylinder should be pushing the steering arm side to side only, not up or down.

Proper placement in front of (or behind) the axle is crucial for optimal performance and reliability. The following is the ideal method for determining this position:

1. Measure and record the greatest distance achievable between the axle center line and the tie-rod mounting hole by turning the knuckle as if to steer.



2. Measure and record the shortest distance achievable between the axle center line and the tie-rod mounting hole by turning the knuckle.

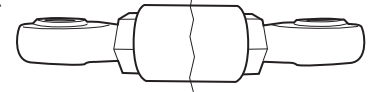

3. Take the average of these two numbers by adding them together and dividing by two. This is the ideal distance from the axle center line to the cylinder center line. Example: the greatest distance is measured at 8" and the shortest distance is measured at 4." Add these together to get 12." Divide this by two to get the mounting distance from the center line of the axle to the center line of the cylinder of 6."



***NOTE: Cylinder Assist Kits 245 and 250 use the supplied fitting in place of the factory return line fitting. All other Assist Kits require the use of the factory return line fitting.

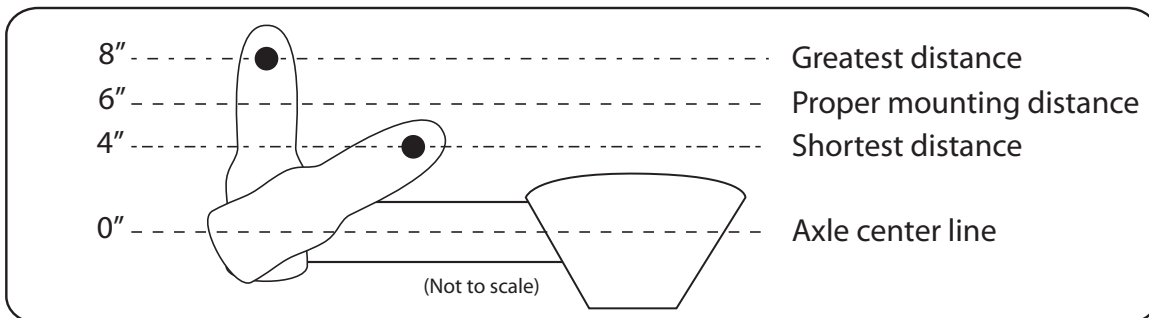
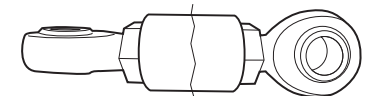



Installation Tips: Steering Cylinder

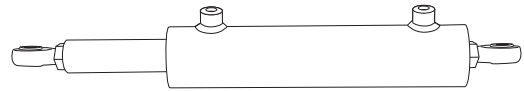

When installing any cylinder it is important to ensure that the rod ends or clevises are mounted in the same plane. This plane should be that which the steering arms create as they move. They should be installed flat (horizontal). This will allow the greatest range of motion and help ensure that no binding occurs. The cylinder should be pushing the steering arm side to side only, not up or down.

Double ended cylinders should be centered between the two steering arms. This will keep the tie-rods the same length allowing the steering system to work consistently throughout its range of motion.

Proper placement in front of (or behind) the axle is crucial for optimal performance and reliability. The following is the ideal method for determining this position:

1. Measure and record the greatest distance achievable between the axle center line and the tie-rod mounting hole by turning the knuckle as if to steer.

2. Measure and record the shortest distance achievable between the axle center line and the tie-rod mounting hole by turning the knuckle.

3. Take the average of these two numbers by adding them together and dividing by two. This is the ideal distance from the axle center line to the cylinder center line. Example: the greatest distance is measured at 8" and the shortest distance is measured at 4." Add these together to get 12." Divide this by two to get the mounting distance from the center line of the axle to the center line of the cylinder of 6."

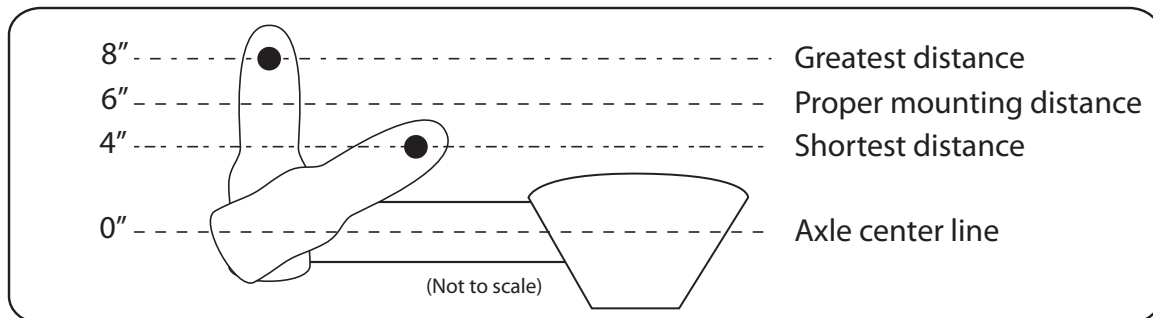
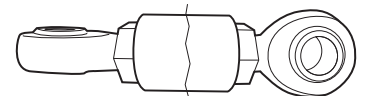
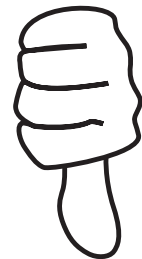



Installation Instructions: Jeep JK Assist Cylinder

*****IMPORTANT:** These instructions apply to factory equipped, non-modified vehicles. Modified vehicles may require special consideration.

Please read through and understand these directions fully before beginning. Do not attempt if you are not 100% comfortable performing the operations outlined below.

Phase 1: POWER STEERING PUMP

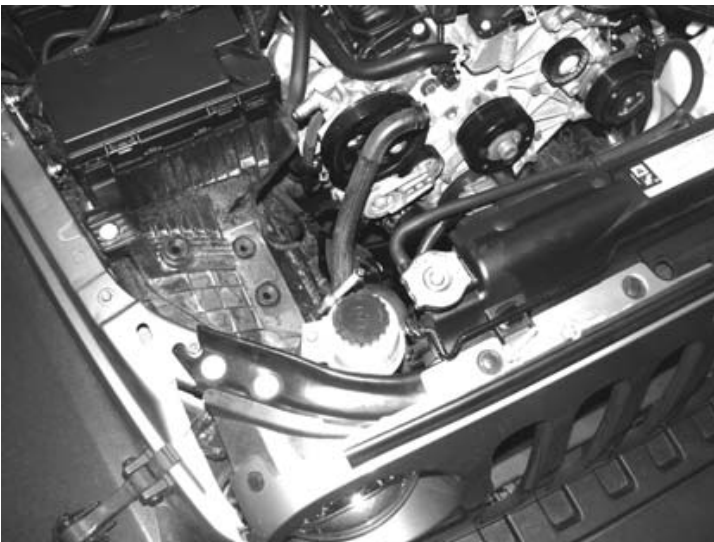

Remove the air cleaner assembly and hose.
Remove the accessory drive belt.

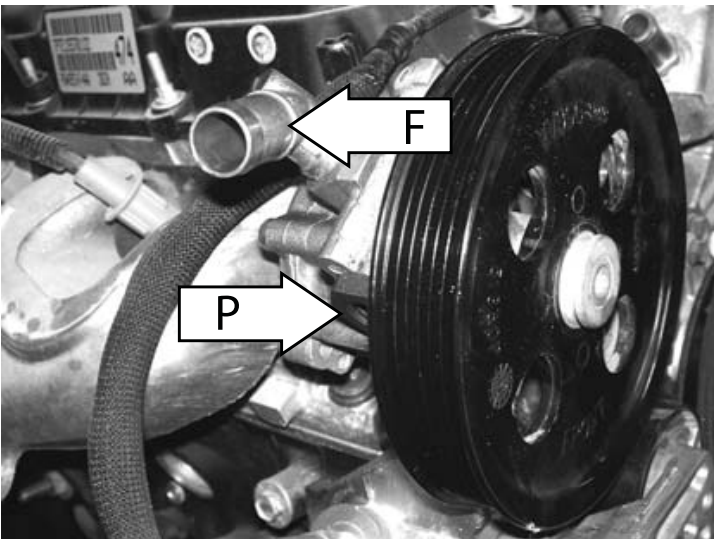

Using a 16mm wrench, remove the pressure line from the pressure port (P).
Remove the feed line from the feed port (F).

With a ratchet and a 13mm socket, remove the 3 bolts holding the pump to its mount.

Remove the pump.

Remove the power steering fluid reservoir using a 10mm wrench.

Install the pump on the factory mount with the factory hardware in the 2 o'clock and the 8 o'clock positions. USE THE SUPPLIED HARDWARE IN THE 4 O'CLOCK POSITION.

Install the factory pressure line into the new pump.

Install the supplied idler pulley in place of the factory idler pulley.

Install the factory belt - replace if worn.

Phase 2: RESERVOIR AND HOSES

Gently pry the wire loom retainer from the edge of the battery box in two locations.

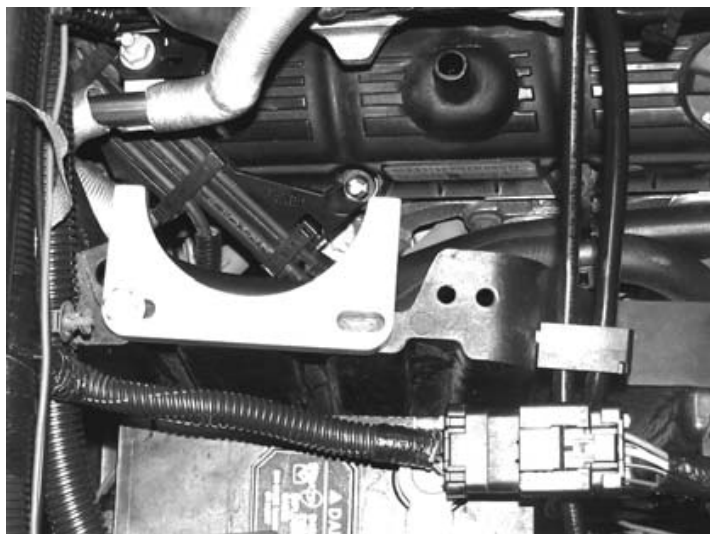

Enlarge the rear most hole using a 5/16 drill bit.

Loosely bolt the reservoir mounting bracket in place.

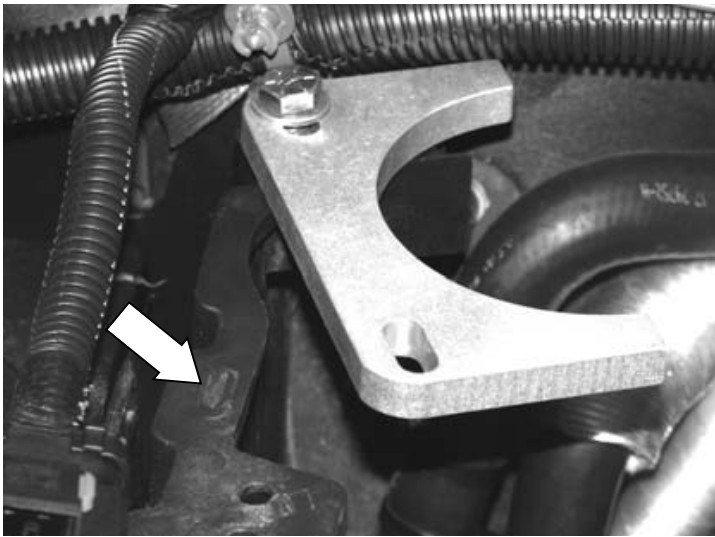

Mark the location for the second hole.

Drill the second hole with the 5/16 drill bit.

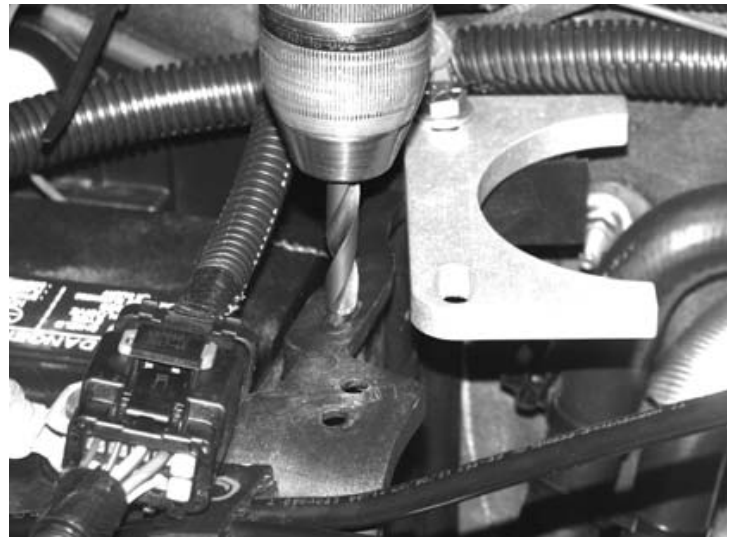

Fully install the bracket with the supplied hardware using a 1/2" wrench.
Mount the reservoir in the bracket with a 5/32" Allen key.
CHECK HOOD CLEARANCE!



Apply a little power steering fluid to the barbed end of a feed line push-on fitting and slide the hose over the fitting making sure it is fully seated.

Install the included 90 degree AN-10 fitting to the feed port of the pump.

Attach the second push-on fitting to the 90.

Install the hose assembly onto the feed port of the reservoir.

Lay the feed line next to the fitting on the pump and mark the location to cut the hose.



Remove the hose assembly from the reservoir and the fitting from the pump.

Cut the hose at the marked location.

Apply power steering fluid to the barbed end of the loose fitting and slide the hose over it.

Attach the 90 to one end of the hose assembly.

Attach the other end of the

assembly to the feed port of the reservoir.

Attach the 90 end of the hose assembly to the feed port of the pump.

Attach the factory pressure line to the pressure port of the pump.





Cut the factory return line just below the first bend on the reservoir end.

Apply some power steering fluid to both small hose fittings and insert one into the factory return line.

Insert the other fitting into the supplied return line.

Connect the two fittings with the supplied adapter. Zip-tie the return line to the pressure line.

Mark and cut the other end of the supplied return line where it meets the reservoir.

Install the hose onto the fitting as outlined above and attach to the reservoir. Install factory belt and air cleaner assembly.



Phase 3: GEARBOX

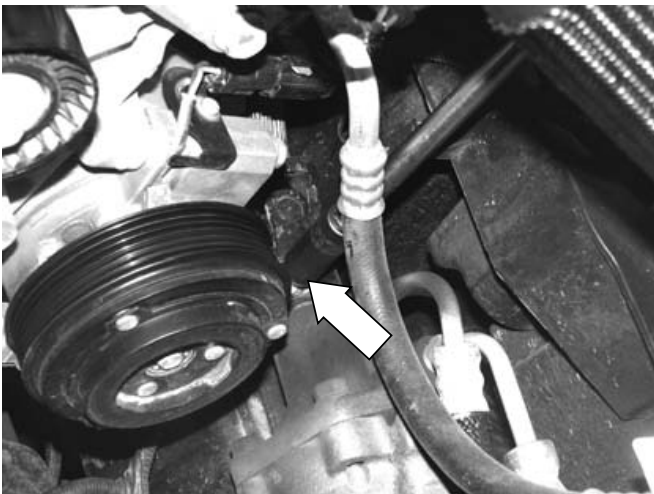

Rotate the steering wheel to provide access to the coupler bolt. Note - tie the steering wheel in place with a bungee or similar. Failure to do so could cause problems with the steering wheel position sensor. Remove coupler bolt and coupler from gearbox with a 13mm socket.

Remove the pressure and return lines from the gearbox with an 18mm wrench.
Remove track bar from vehicle using a 21mm socket.

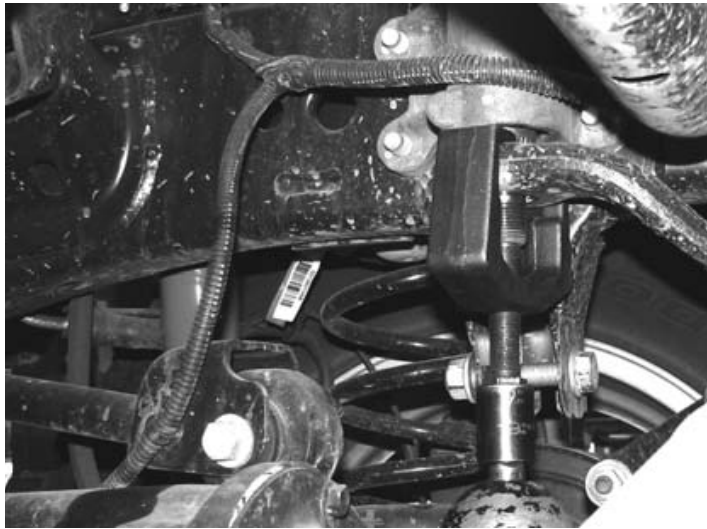
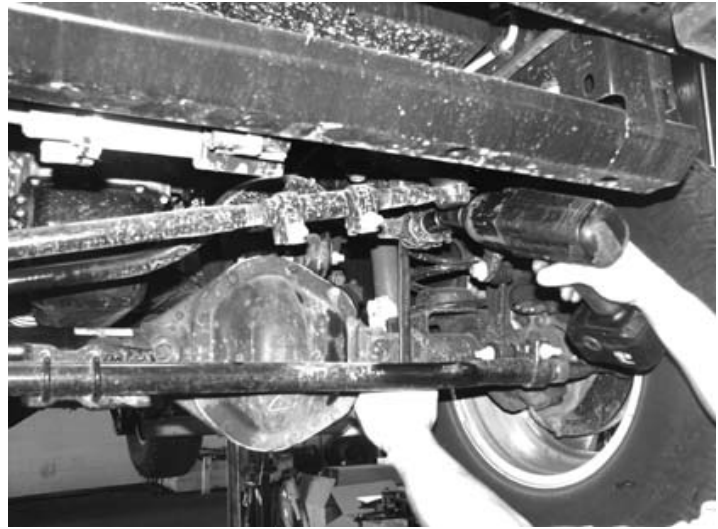

Remove pitman arm nut with a 32mm socket.
Remove pitman arm with a pitman arm puller.

Remove gearbox with an 18mm socket. (It may help to pull the wheel sensor at the left upper shock mount)



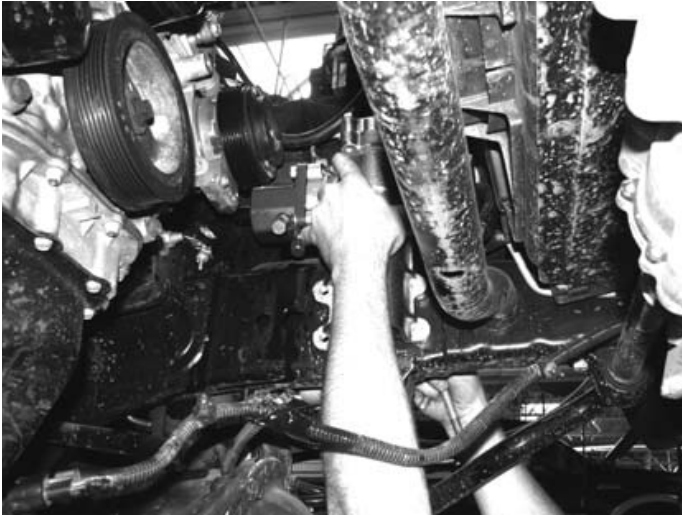

Install the new gearbox in the stock location using the factory hardware.

Attach the pressure and return line to the new gearbox.
Install the old pitman arm on the new gearbox. (The pitman arm should go straight forward from the box then hook to the driver side)
Re-attach the wheel sensor, if removed.

Phase 4: ASSIST CYLINDER

Remove the steering stabilizer.
13 and 18mm socket required
Cut the lower stabilizer brackets from the axle housing. (These may alternatively be bent out of the way with a hammer)



Mount the cylinder bracket to the axle housing at the track bar mount, the right shock, and around the axle tube with the supplied hardware while installing the track bar.





Loosely bolt the tie-rod bracket to the tie rod.

Install the rod ends on the cylinder making sure they are parallel with one another.

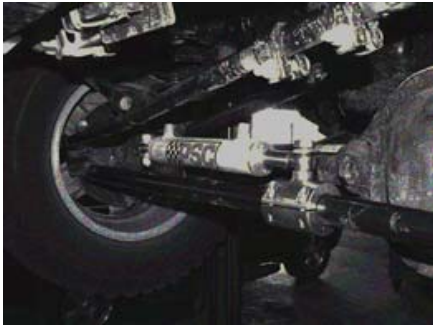

Install the cylinder.
***See cylinder installation instructions**

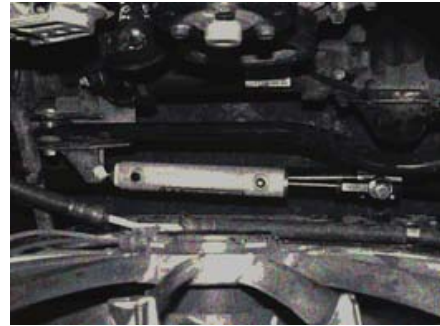

Turn the wheels full right and bottom out the cylinder.

Tighten the cylinder tie-rod clamp.

Install hoses: Make sure that the hoses will not be over-extended when the suspension is at full droop. It may help to set the hoses up with the suspension at full droop. Install pressure hose on a 45 degree fitting ***see fitting instructions** and place on the right side of the cylinder so that the hose will angle up and to the left. Install pressure hose on the straight fitting and place on the left side of the cylinder. Cut the hose to the proper length and install onto the remaining two 45 degree fittings. Attach these hose assemblies to the

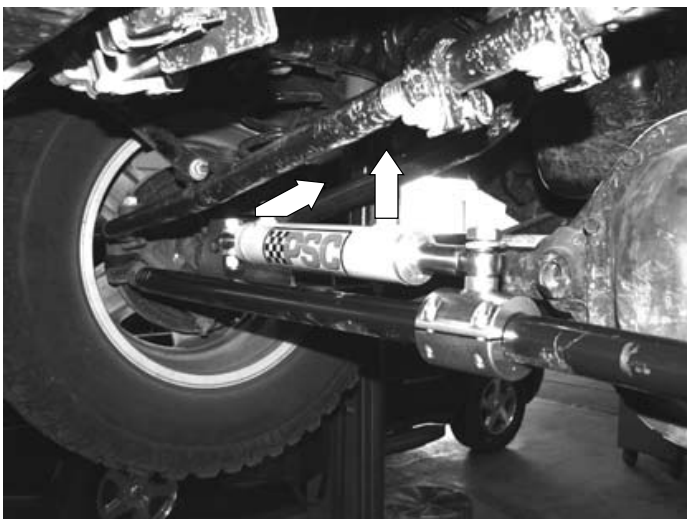

gearbox so that the hoses angle down and slightly forward - refer to the ***cylinder assist hose routing diagram** for correct port configuration.

The hoses should be routed over the track bar. The hoses can be zip-tied together for a neater installation.

Bleed the system according to the ***bleeding instructions**.

How to install a PSC 1475 P Series Pump Kit



The 1475 pump bracket bolts onto the manifold where the original TC series pump was.



The radiator overflow bottle also has to be moved, removed or replaced with a smaller bottle.

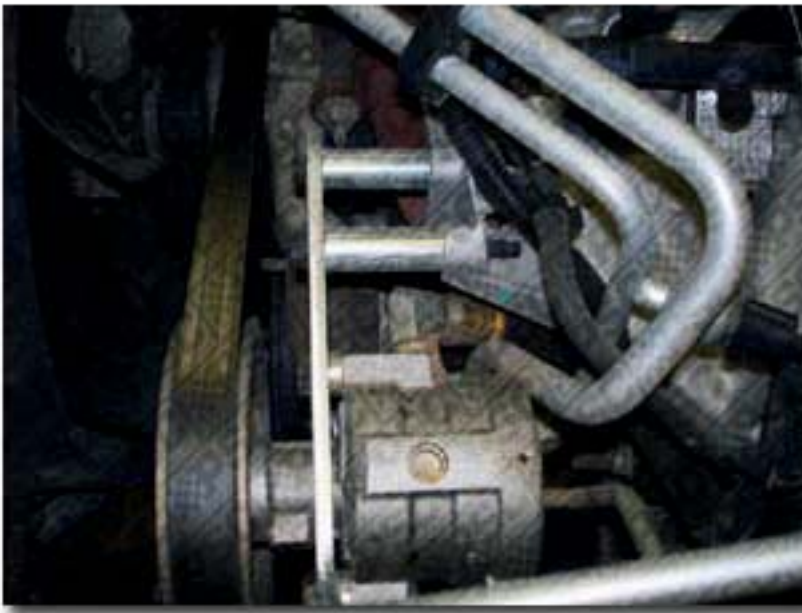

#10 Suction hose routes between pump and engine and up to remote reservoir on the side.



This kit does offset the pump out board towards the drivers fender more and does require moving the windshield fluid bottle a little. This particular vehicle has aftermarket fenders and the windshield fluid bottle was removed.





With this particular vehicle we chose to remove the overflow bottle and install a 20# cap. We have had no issues at all by doing this. Being a Texas vehicle, 110 degree days have not been a problem, nor has high altitude driving. Also by going to a higher pound cap you increase the boiling temp. (old racers trick)



The remote reservoir mounts up by the master cylinder. Your return line from the steering gear feeds into the bottom.



ROCKCRAWLERSM

PSC Hydraulic Steering Assist System

Let's face it, bigger tires at lower pressures are a pain in the...rocks! If you've ever run larger-than-stock tires on a vehicle with manual steering, it's easy to appreciate power steering. And, if you're running even bigger tires, it's time for the ultimate upgrade - a PSC Hydraulic Steering Assist system! Depending on your application, PSC's kits have almost everything you need, including a hydraulic ram, heavy duty steering gear box, high pressure/volume pump, remote reservoir, mounting tabs, and high-quality hoses and fittings.



For years I've run stock Jeep power steering on my old CJ's, with the only real performance upgrades being a Borgeson steering shaft, a Big Daddy Off-Road heavy duty steering gear bracket, a used steering gear out of a YJ, and a Currie Enterprises steering box brace. Now that I've upgraded from Scout Dana 44 axles to a Dana 60 and GM 14 bolt combo, and with plans to go to 44" tires in the not-too-distant future (hopefully), I felt it was finally time to upgrade my steering system.

After considerable consternation, I decided to go the most durable, dependable way possible, and called the folks at Poison Spyder Customs and ordered the stronger steering components needed to do the job - high steer arms, heim joints, misalignment bushings, 1.5" .250 wall D.O.M. tubing, and tubing adapters.



While the fabrication and installation of the above components is not specifically covered in this article, installation of a hydraulic

While the fabrication and **installation** of the above components is not specifically covered in this article, installation of a hydraulic ram obviously puts more stress on steering components. Prior to installing this upgrade, you should make sure that every aspect of your steering system is up to snuff, including ball joints or kingpins, tie rod and ends, drag link and ends, and Pitman arm. You should also strongly consider a stronger steering gear bracket, especially on a CJ, as the stock stamped steel brackets crack and break frequently. Also, the addition of a cross-brace is highly recommended. Without one, excessive force from bigger tires can eventually result in a **cracked** frame around the gear box. Not fun, especially when it happens on the trail! (If you don't think you need one, invest in an on-board welder...you'll need it!)

Once you've got stronger components **installed**, you're ready for installation of one of PSC's Hydraulic Assist Kits. It's not really too difficult, but does require some good quality welding, and a bit of common sense. Let's get to it!

Installation

It really doesn't matter what you do first, but let's start with the gear box. No matter how hard you try, you're going to make a mess, but one way to **avoid** a good portion of it is to use an old turkey baster to remove as much of the power steering fluid from the pump reservoir as possible first.

Next, remove the tie rod from the Pitman arm and the steering shaft from the steering gear input shaft, and all but one of the top steering gear mounting bolts. Then, loosen that bolt enough to gain more clearance to remove both power steering hose lines from the gear box, using a container to drain more power steering fluid from the pump and lines. While supporting the gear, remove the last bolt completely, and set it on the bench next to the new PSC steering gear. Then, remove the lines from the back of the old pump and loosely **install** them on the new gear. If these lines are old, now's a great time to replace them.



I then installed the plugs from the new gear into the old one for storage purposes. Normally, the steering box bracket uses all bolts to secure it to the gear, but the Big Daddy Off-road bracket uses studs and spacers which must be transferred from one gear to the other, in the proper orientation. Also, you must remove the Pitman arm with a puller. If it's been on there awhile, try soaking it good with WD-40 and after the puller is installed and snugged down real good, hit the side of the Pitman arm with a good-sized hammer a few times. This will usually "convince" it to pop off.

Regarding the Pitman arm, I replaced the relatively weak stock CJ arm with a heavy duty **version** from a Ford truck. It is almost exactly the same length, but the Ford arm doesn't neck-down like the old one does. I've bent a stock CJ Pitman arm before. Imagine the extra force generated with the hydraulic ram. I **suggest** you replace this weak link now, not later - on the trail!



I waited to install the Pitman arm on the new gear until after the box was bolted back on the frame. It's a lot easier to tighten down that big nut then! You can either go ahead and install the box now or wait. It's up to you.

Next is the pump. This is a little more involved, but with a little patience and the right tools, it's not too difficult. Depending on your application, you'll need a pulley remover/**installer** to transfer your existing pulley from the old pump to the new one. I found an inexpensive version at good ol' Harbor Freight that worked just fine. Remove the pump, noting how



I waited to install the Pitman arm on the new gear until after the box was bolted back on the frame. It's a lot easier to tighten down that big nut then! You can either go ahead and install the box now or wait. It's up to you.

Next is the pump. This is a little more involved, but with a little patience and the right tools, it's not too difficult. Depending on your application, you'll need a pulley remover/installer to transfer your existing pulley from the old pump to the new one. I found an inexpensive version at good ol' Harbor Freight that worked just fine. Remove the pump, noting how the brackets were installed, and stick it in the vise. If you don't have a big vise, get one, or remove the pulley before you pull the pump off the engine.



My CJ actually has three pieces to the bracket, and one is located under the pulley. Also note exactly how far the pulley was installed on the old pump. Assuming your belt(s) were aligned properly in the first place, this will help get the new one right the first time. Use your puller to carefully remove the pulley and also remove the two mounting studs from the back side of the pump.





ROCKCRAWLER™

PSC Hydraulic Steering Assist System

Time for the new PSC pump. Carefully mount the snout end of the new pump in the vise and **install** the two mounting studs. Put the nuts on to **avoid** damaging the threads, invert the pump, and then **clamp** the studs/nuts in the vise firmly. Place your old pulley on the pump, and use your pulley **installer** to carefully force the pulley onto the pump shaft at the same depth as the original. If applicable, don't forget to install the front portion of the pump bracket first!



If you haven't already, install the new gear, hooking up the steering shaft and tightening down the lines, making sure they're routed properly to clear other components. Next, **reinstall** the new PSC pump, installing high and low pressure lines, and tightening the belts to spec. Whatever you do, **DO NOT** pry against the soft pump main reservoir! Use a wrench on the boss cast into the pump. That's what it's there for!

Once you've got the new PSC gear and pump **installed**, you'll have to figure out where to mount the remote reservoir. It obviously needs to be relatively close to the pump, and should be higher than the pump if at all possible to make bleeding air from the system easier. As you can see, I elected to fabricate a small bracket that bolts down using one of the **intake manifold** bolts and bolts to the reservoir bracket itself. This allowed me to use the PSC supplied hose, with the 90 degree fitting screwed into the side of the reservoir, and the straight fitting going into the main pump reservoir.



While you're in this area, you may as well go ahead and plumb the remaining low pressure lines. This is a good time to consider adding a power steering fluid cooler, if you haven't already. There are many types available, and I chose to continue to run the same one I have for years, mounted to the front of the electric pusher fan sitting in front of the radiator. Another thing to consider is the use of synthetic power steering fluid, such as **Royal Purple's Max EZ**, which runs significantly cooler. Either

consider is the use of synthetic power steering fluid, such as [Royal Purple's Max EZ](#), which runs significantly cooler. Either way, connect the low pressure line from the power steering gear to the bottom of the remote reservoir, using the PSC supplied hose and fitting.

Now, the fun starts! You've probably already thought about this, but you first need to figure out the right way and place to mount the hydraulic cylinder (ram). And, this is where I get to admit that my first attempt was definitely the wrong way! My hesitance to weld to [cast iron](#) got me in trouble. What can I say?



Anyway, we'll get back to that in a bit. As you could see from the "before" [photos](#), I had decided to mount my tie rod behind the [differential](#), out of harm's way. After assembling the heim joint ends to the ram, and figuring out the half-way mark for the travel of the ram rod, I got out the Sharpie marking pen to mark the location of both the fixed end of the ram and the working end. In my first attempt at this, I was using two of the including weld-on mounting tabs to mount the fixed end, and a prototype tie rod mount that PSC had supplied me with. This threaded tie rod mount is a beautiful piece of machining! Once the mount locations were determined, I tack-welded the fixed end mounting tabs in place and then the tie rod mount.



Once I installed everything again to verify clearances, I called the tech folks at PSC, as I was a bit concerned about the [angle](#) of the ram. They explained that a [small](#) amount of angle was usually OK, but that the more parallel the ram is to the tie rod, the better. I had more than a small amount, but felt it would work, so I finished welding and painting, eager to get done so I could try this new "toy" out! This Jeep hadn't been on the trail in a long time. I was more than ready to go 'wheelin'!

The last thing to do is to "build" the high pressure lines that go from the ports tapped into the new PSC steering box to the hydraulic cylinder. The steel reinforced hose comes in one length, and must be cut (I used a hacksaw) to fit your [application](#). Remember to allow for travel of the axle, and clearance of suspension and other components when determining length. After some careful inspection and measuring, I decided to just cut the hose in half, figuring that I could always shorten it in the future. Since these high quality hose-end fittings are reusable, this would be no problem at all. Basically, all that's required is to "thread" the hose into the large outer fitting, with the inner fitting threaded almost all the way out.



Once I installed everything again to verify clearances, I called the tech folks at PSC, as I was a bit concerned about the **angle** of the ram. They explained that a **small** amount of angle was usually OK, but that the more parallel the ram is to the tie rod, the better. I had more than a small amount, but felt it would work, so I finished welding and painting, eager to get done so I could try this new "toy" out! This Jeep hadn't been on the trail in a long time. I was more than ready to go 'wheelin'!



The last thing to do is to "build" the high pressure lines that go from the ports tapped into the new PSC steering box to the hydraulic cylinder. The steel reinforced hose comes in one length, and must be cut (I used a hacksaw) to fit your **application**. Remember to allow for travel of the axle, and clearance of suspension and other components when determining length. After some careful inspection and measuring, I decided to just cut the hose in half, figuring that I could always shorten it in the future. Since these high quality hose-end fittings are reusable, this would be no problem at all. Basically, all that's required is to "thread" the hose into the large outer fitting, with the inner fitting threaded almost all the way out.



Suggestion: Clamp the large outer fitting in a vise in a position that allows you to thread the hose into it by hand. Don't be shy, thread as far as it will go. Then, reposition the fitting so you can use the appropriate wrench to tighten the inner fitting all the way down, as shown in the photo.



ROCKCRAWLERSM

PSC Hydraulic Steering Assist System

Once the hoses are built, install them on both the ram and steering box, in the proper orientation. What's that? Well, if your tie rod is behind the axle like mine, connect the rear port of the box to the passenger side port of the ram and vice-versa for a tie rod in front of the axle. This will allow the steering box direct pressurized fluid to the correct end of the ram, depending on which way you're turning the steering wheel. Position the hose fittings for proper clearance of the hose, and tighten 'em down.



Remember to fill the system with the power steering fluid of your choice. I filled the reservoir and let gravity bleed the system a couple of times, and then started up the engine, adding fluid almost immediately. Then, I cycled the steering wheel back and forth slowly a few times, rechecked and topped off the fluid as necessary.

Testing

My first opportunity to test my work was at the Texas Spur Jeep Jamboree, help on the historic Inks Ranch, just south of Llano, Texas. I've been a Trail Guide at this and the YO Ranch Jeep Jamboree for years, and always look forward to running with my fellow San Antonio Jeep Exclusive (SAJE) members who help make this event one of the most successful of the Jeep Jamborees.



While not particularly difficult Jeepin', this was a good place for a shake down of all the new modifications, specifically my new PSC Hydraulic Assist setup! The PSC system worked great...my installation didn't. If you look very closely at the next photo, you may see why. Because the ram was mounted at such an angle, and because the tie rod mount was offset from the center of the tie rod, and because I used heim joints instead of tie rod ends, the tie rod was able to unlock the heim joint jam nuts. This allowed the entire assembly to rotate in both directions, depending on the way the wheels were turned. This would allow the tie rod to contact the ram rod, causing a clunk from time to time. No amount of tightening or Lock-Tite could keep the nuts from loosening up, as there was just too much turning force because of the angle of the ram.



Fortunately, this happened on the last day of the Jamboree, and because I took it easy, no damage resulted. Soon after I got home, I removed the hydraulic ram and began the task of properly mounting the ram.

Installation - Revisited

Using two more weld-on tabs that put the ram between them instead of along the side, I repositioned the ram in the opposite direction, mounting the fixed end to the top of the differential, and the working end in an almost parallel position to the tie rod. Obviously, I should have done this in the first place! Oh well, live and learn, right?



After preheating the cast iron differential housing for a few minutes with the torch, I cranked up my Hobart Handler 175 all the way to setting #4, and welded to new mounts on. I then welded on the tie rods tabs, later grinding off the old prototype mount. Regarding the prototype, it would probably have worked fine after proper mounting of the ram, but I wanted to do everything I could to reduce the ability of the tie rod to twist, so I felt mounting the ram heim joint between two tabs would be better.

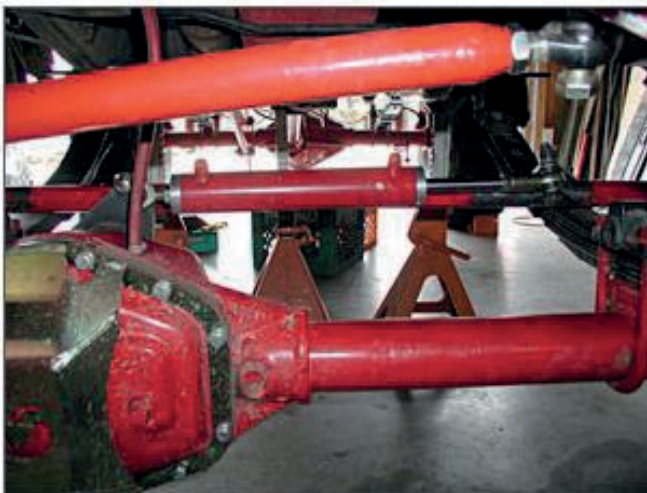

Testing - Phase 2

The ultimate test was conducted in Farmington, NM and Cortez, CO. Without a doubt, the PSC Hydraulic Assist System passed with flying colors! This "phase" of testing included various extreme trails and obstacles around Farmington, and trails on BLM and private land around Cortez.

Testing – Phase 2

The ultimate test was **conducted** in Farmington, NM and Cortez, CO. Without a doubt, the PSC Hydraulic Assist System passed with flying colors! This "phase" of testing included various extreme trails and obstacles around Farmington, and trails on BLM and private land around Cortez.



For years, after a day of rockcrawling and man-handling my 38" Swampers around, I was worn out! My PSC system has **changed** all that! I should've done this a long time ago! No longer do I have to fight to keep my tires on the line I want. What a difference! This has to be one of the most significant upgrades I've made to my Jeep! I can't wait to get bigger tires...

PSC has a hydraulic assist kit for just about every rig out there.



Installation Instructions: SB100, SB300 Dodge Steering Box Stabilizer Bracket



1. Remove pitman arm retaining nut and lock washer, 1-5/16" socket or wrench required.
2. Install new pitman arm retaining nut and lock washer. Torque to 185 lb/ft.



4. Slide the steering brace around the anti-sway bar and push everything together back against the frame while guiding the new sector nut through the hole in the brace flange. Install the new 10-1.5 x 40mm bolts, lock washers and flat washers - make sure the hole in the flange is centered around the new sector shaft nut - then tighten to 36 lb/ft. Retighten the anti-sway bar link nuts.



3. Remove sway bar bushing mount bolts, 15mm socket required. Drop anti-sway bar down and loosen sway bar link nut until flush with the end to ease installation.



5. Install the bearing block on the the new sector nut. It is a tight slip fit, a soft face hammer may be required to tap the bearing into place.



Installation Instructions: SB100, SB300 Dodge Steering Box Stabilizer Bracket



6. Install the 7/16-14 x 2 bolts with flat washers on both sides and nylon locknuts, torque to 75 lb/ft.



8. To complete the job, grease the bearing block.



7. Tighten set screws in the collar of the bearing block

Parts list:

2	7/16-14 x 1-1/2 GR8HHD	PC-F080
2	7/16 FLAT WASHER	PC-F129
2	7/16-14 NYLON LOCKNUT	PC-F067
4	10mm LOCK WASHER	PCF066
4	10mm FLAT WASHER	PCF034
4	10-1.5 x 40mm HHD	PCF136
1	7/8 LOCK WASHER	PC-F003
1	Dodge Brace Sector Nut (SB-100-HK only)	SB-NT-01
1	Dodge Brace Sector Nut (SB-300-HK only)	SB-NT-02



Installation Instructions: SA-HS60 D60 Adjustable Preload High-Steer Arm

*****SAFETY NOTE:** The compression spring under the steering arm or upper kingpin bearing cap is under a substantial load. Nuts at the steering arm, or bolts at the upper kingpin bearing cap, must be removed a little at a time in a criss-cross pattern. Failure to do so could result in forceful ejection of the spring which could cause serious injury.

Remove the four nuts at the steering arm a little at a time in a criss-cross pattern. Remove steering arm, spring, and spring retainer.

Remove the kingpin bushing from the top of the steering knuckle. Clean the top of the knuckle and the cavity around the kingpin thoroughly.

Install the supplied studs into the knuckle using red loctite (or similar) with the long-threaded end of the stud exposed. Tighten until fully seated.

Apply a generous amount of quality high-temp bearing grease into the kingpin cavity (including the hex in the top of the kingpin). Notice the slot in the housing into which the kingpin bushing will be keyed.

Grease the kingpin bushing and install, indexing the ridge on the bushing with the slot in the knuckle.

Place the supplied thick metal disk on top of the kingpin bushing.

Place the steering arm over the studs and lower into place ensuring that the disk seats in the arm.

Install the supplied nuts. These go on like a lug nut, fitting into the taper in the arm. Tighten in a criss-cross pattern working up to 100 lb-ft.

Install grease zerk and fill with grease until set-screw hole begins filling.

Install set screw and tighten while rocking the knuckle back and forth. Continue tightening until the knuckle is almost locked in place. Back the set screw off $\frac{1}{4}$ turn. Rotate the knuckle. You want it to have *some* resistance.

Install the jam nut and torque to 45 lb-ft.



Parts List: SA-HS60 D60 Adjustable Preload High-Steer Arm

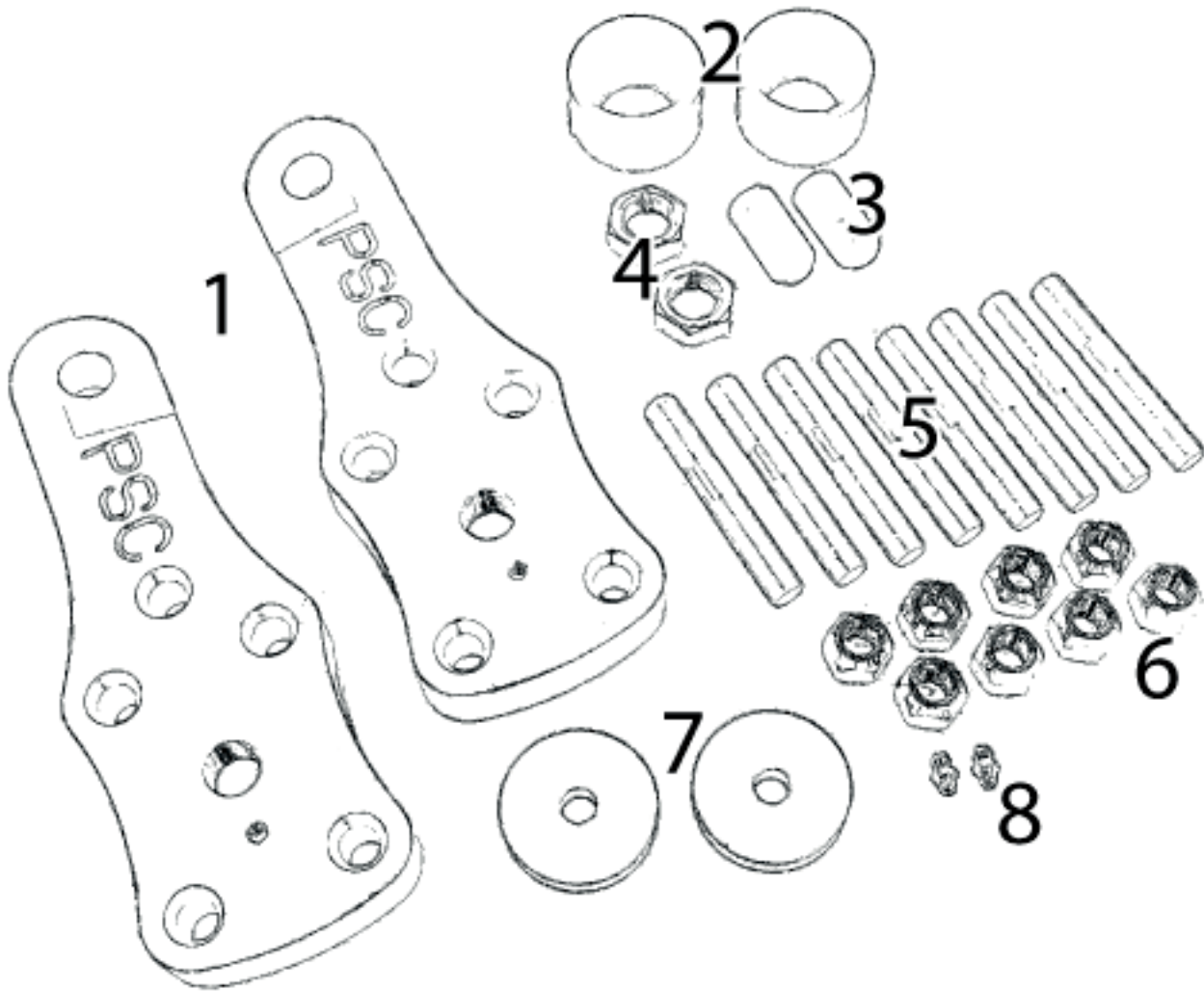

- 1. Steering Arm (L/R)
- 2. Kingpin Bushing (2)
- 3. Set Screw (2)
- 4. Jam Nut (2)

- 5. Stud (8)
- 6. Lug Nut (8)
- 7. Thick Metal Disk (2)
- 8. Grease Zerk (2)

Reuseable Fitting Installation



First you need to determine the length of hose required and cut to length. We suggest using a abrasive cut off wheel. Then clamp hose in vise with about 1.5" protruding out.



Next thread the shell onto the hose counter clockwise until the hose bottoms out in the fitting.



Next clamp down on the shell with the vise.



Apply some oil to fitting.



Now thread the fitting into the shell clockwise. You do not need to bottom out the fitting. You can leave a couple of threads showing. If install 90 degree fittings on both ends of the hose you will find that you will probably have to clock the fittings.



Job complete!

Single Cylinder Bracket Kit Mounting instructions

Remove pinion yoke. Remove dust shield. Cut the flange off of the yoke. Clean-up and reinstall yoke.



Remove three bolts from the pinion flange. Install and tighten the cylinder bracket (stamped "T" UP) w/ provided spacers and new 3 1/2 bolts w/ lock washers.



Top view



Front view

Remove three bolts from the side carrier cover. Install and tighten the side bracket (stamped "T" UP) w/



Side view

new 2" bolts and lock washers.

Use clamps to properly align cylinder bracket and side bracket. Tac-weld into place.



Side view

Tac-weld gussets into place. (1/2" from top and bottom).

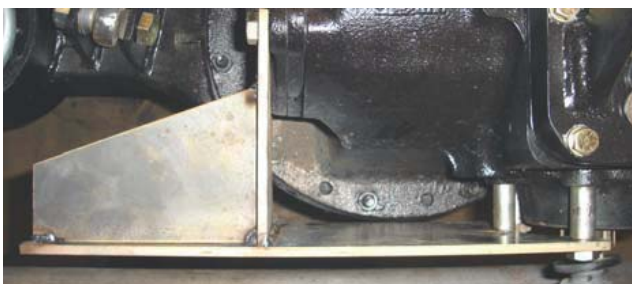

Top view



Side view

Finish welding out all accessible joints on brackets and gussets.

While kit is cooling install your **high steer arms**.



Remove steering arm.



Remove studs from steering knuckle.



Remove bolts and top plate from opposite knuckle.



If your axel has them, be sure and retain the spacers under the old arm and under the top plate.



Spacer



spacer shown w/ top plate for size comparison

Install high steer arms with new bolts & lock washers provided. Torque to 130-140 ft/lb.

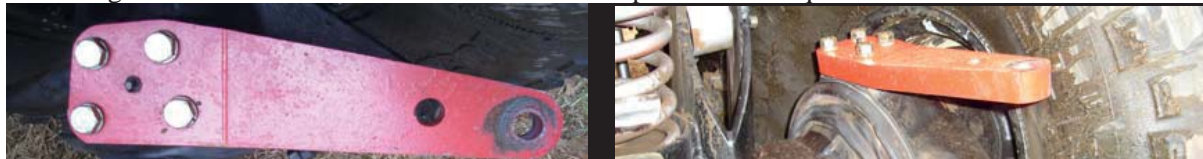

Position clamps just to the inside of the hose mounts and tape cylinder to protect from welding splatter.

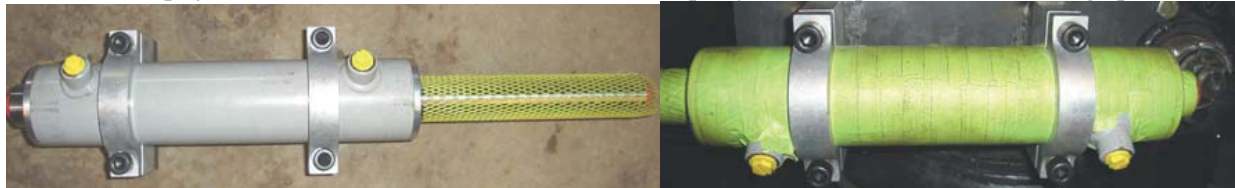

Find center of axel and mark on cylinder bracket. Center the cylinder and clamps on the cylinder bracket, align top of cylinder clamps FLUSH with top of cylinder bracket. Tac-weld into place.



Remove cylinder and finish welding cylinder mounts to the cylinder bracket.



Allow kit to cool before removing.

Remove kit and finish welding any missed joints. Allow to cool.

Re-install kit and mount cylinder. Adjust shaft for an equal amount on each side. (approx. 4 1/2")



Install a clevis into each cylinder shaft end. Be sure that you align them threaded side down.



Install provided rod end w/ jam nut and threaded insert into the clevis (left hand) and high steer arm (right hand). Leave approx. 3/8" of thread exposed for adjustment.



Left hand threads



right hand thread

Measure between threaded insert "shoulders", both sides should be equal if the toe is properly set. Cut provided tubing pieces, to length, for both sides. (Approx. 8")



Remove threaded inserts from rod ends and tac-weld into tubing. Weld out and allow to cool.



Re-install rod ends, align knuckles for proper toe adjustment, and tighten down jam nuts.



Final product!!



READ FIRST

*****IMPORTANT:** Pump WILL be damaged if the following procedures are not followed.

Always use an automotive power steering pulley puller for pulley removal.



Always use an automotive power steering pulley installer for pulley installation.



NEVER USE A PRESS OR HAMMER TO INSTALL OR REMOVE PULLEY!

NEVER use automatic transmission fluid (ATF). Use only standard power steering fluid or synthetic power steering fluid (Valvoline semi-synthetic blend is NOT recommended).

*NOTE: All 1400 series pumps without an 'F' in the part number are metric - all threaded holes in the pump are 10-1.5mm. Use of 3/8-16 hardware can crack the pump case.

Failure to follow these procedures will void any and all warranties in ALL cases with no exceptions. Customer will be charged for any repairs necessary on product returned in these cases.

Installing the PSC upgraded steering gear in place of your stock TJ gear will require shortening of the steering shaft. This is easily accomplished by removing the plastic pin that joins the two halves of the telescoping shaft. A hand-held drill works well for this.

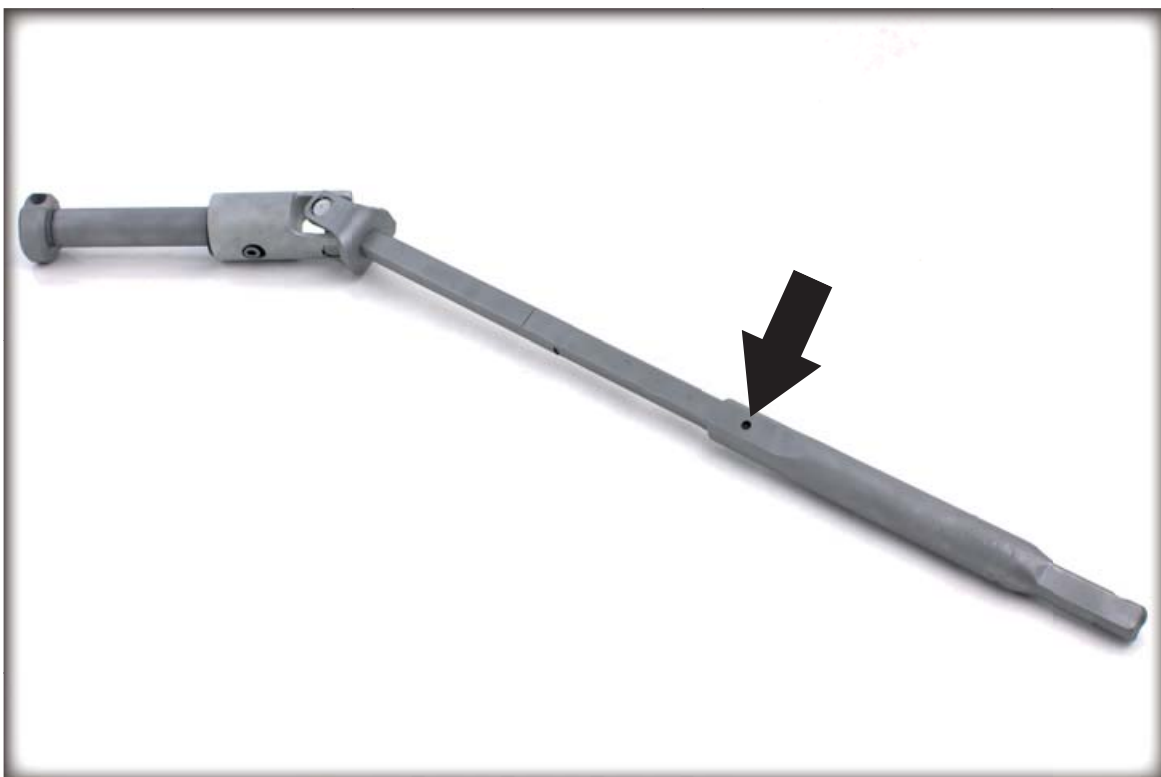



Start by removing the grille.

1



Remove the parking lights.

2



Take the wire loom loose from the header panel.

3

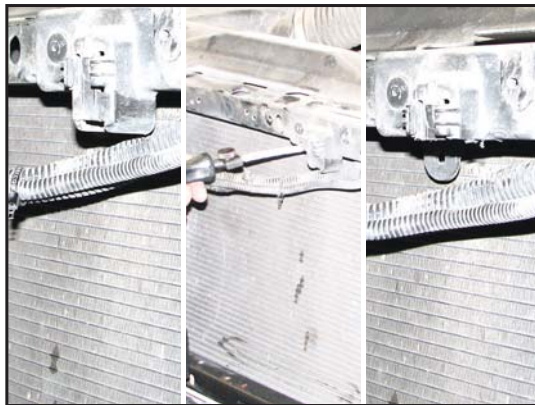

This piece may require trimming for clearance.

4

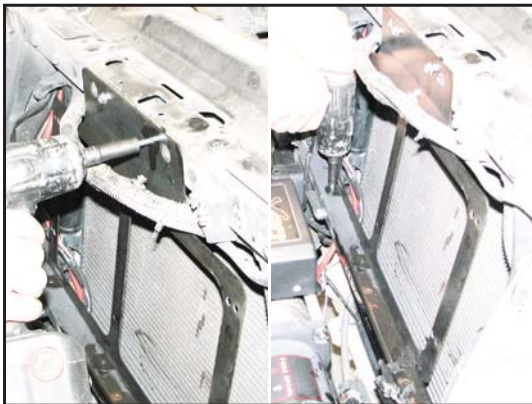

Using the included self-drilling, self-tapping screws install the cooler bracket.

5

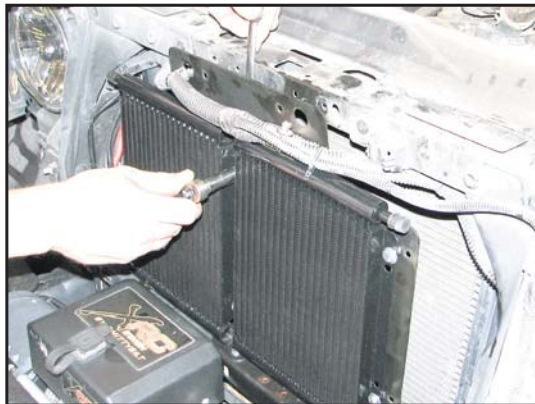

It may be necessary to remove the top 2 screws to gain access to the back of the bracket for mounting the coolers.

6

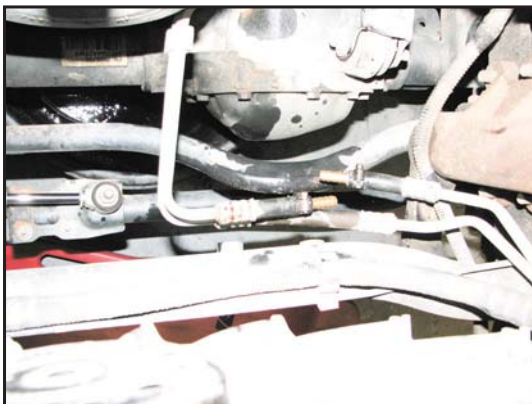

The upper line is the return to the transmission. Cut in the center of the hose. Install two "hose menders."

7



The line from the radiator should go into the bottom of the cooler. The other line should come from the top port of the cooler and go into the transmission return line.

8



Ensure that a radius exists in the line large enough to prevent hose collapse.

9



Remove the air cleaner assembly.

10



Remove the bolt holding the power steering reservoir in place.

11



Cut the 90 degree bend from the power steering return line. Insert a "hose mender" into the remaining hose.

12



Again, ensure that a loop of sufficient radius is used to prevent any kinking of the hose.

13

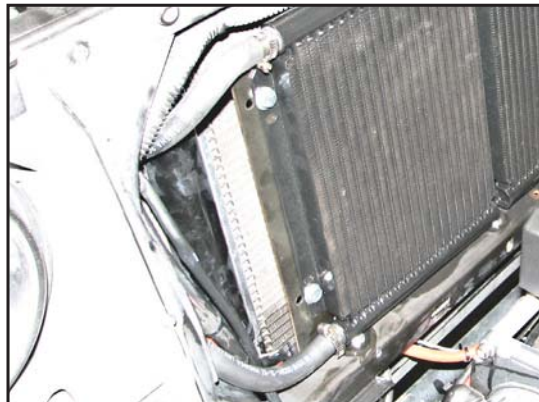

The hose from the steering gear should go into the lower port of the cooler. The upper port should connect to the reservoir.

14



Reinstall items removed during installation then bleed the power steering system according to the enclosed bleeding instructions.

15