

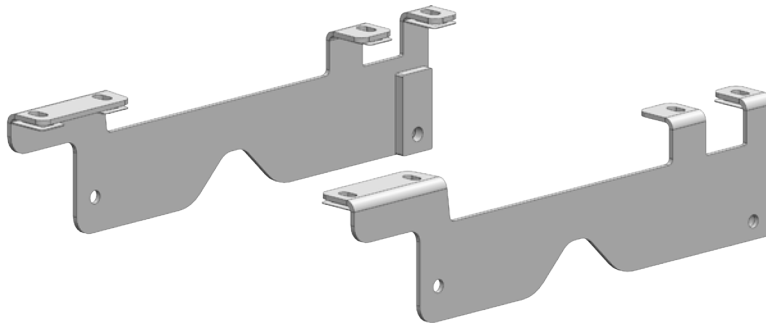

FORD

20K Industry Standard Rail Custom [Mounting Kit](#)

#2760



Gross Trailer Weight (Maximum) 20,000 lbs.
Vertical Load Weight (Max. Pin Weight) 5,000 lbs.

SYSTEM TOW CAPACITY

Please note, in order to determine the **total tow capacity** of a system, you must consider the weight ratings of each component in that system. This includes, but may not be limited to, the capacity/rating of the **tow vehicle**, the **five wheel hitch**, and the hitch's **mounting system**. Actual tow capacity of the system will be equal to the lowest rated component.

Installation Instructions

SPECIFICATIONS

- Fits 2015-2016 Ford F-150
- King pin is located 1-1/4" ahead of axle
- Custom Mounting Bracket Kit (*Bracket & Hardware*) #2761

PLATE ASSEMBLY

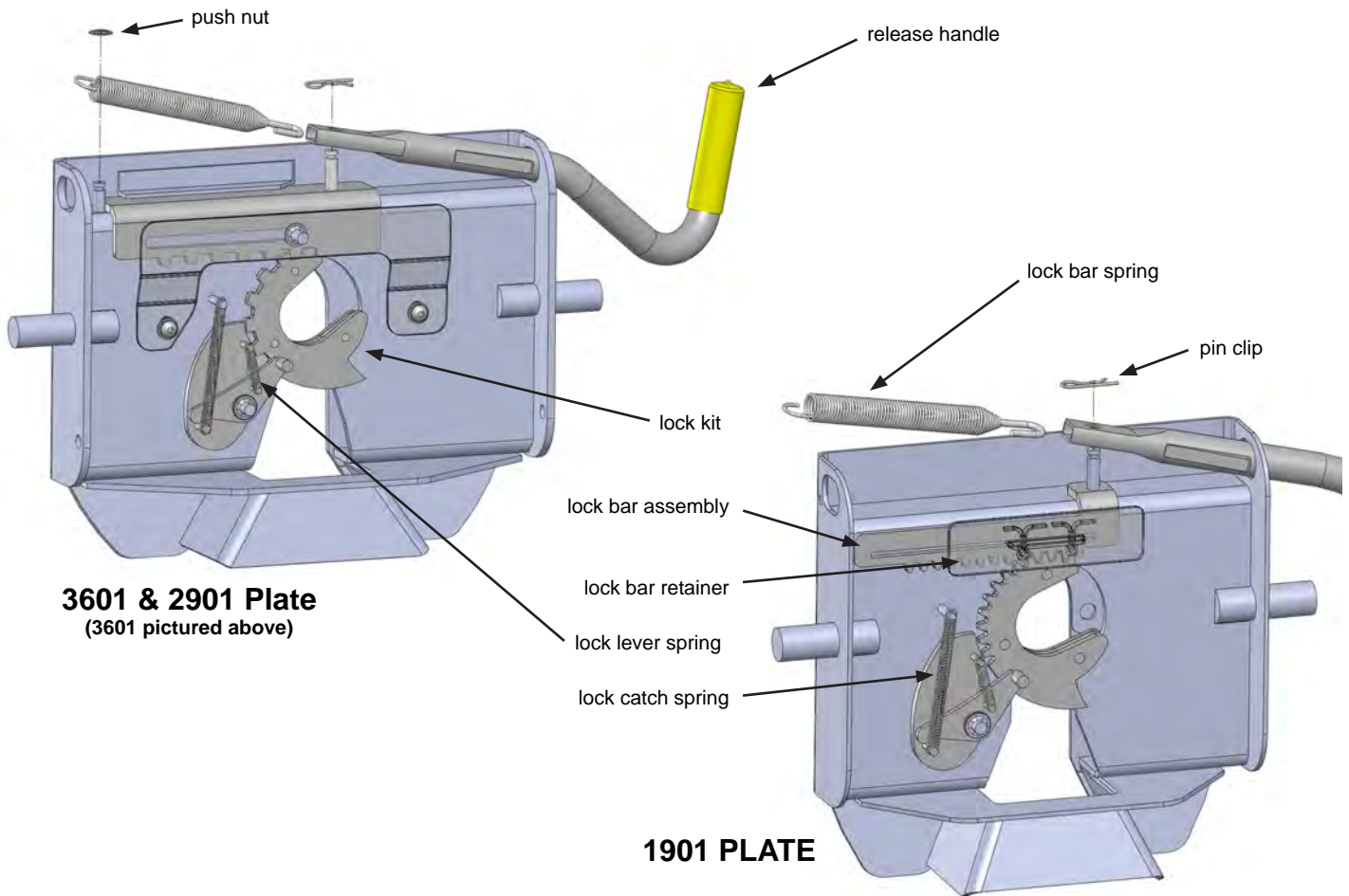

1. Remove the Fifth Wheel Plate from the Rocker Arm and place it upside down on a smooth, clean surface.
2. Insert the Release Handle into the obround hole of the plate as seen above.
3. The Lock Bar Spring must be placed inside the handle prior to placing the handle down over the pin of the Lock Bar Assembly, "catching" the hook inside the handle around the pin.
4. Push the handle and spring assembly down past the groove in the pin of the Lock Bar Assembly, and place one of the Pin Clips in the groove of the pin to fasten.
5. Grip the body of the spring and stretch it far enough over the opposite pin (welded to the plate) and push it down past the groove.
6. Install the Push Nut to secure the Lock Bar Spring onto the welded pin.

NOTE: The 1901 plate for the #1900 Super 5th does not use a push nut to attach the end of the spring, but rather a slot in the side of the fifth wheel plate located above the obround hole. See illustration to the right.

As a PullRite fifth wheel hitch owner, it is important for you to study and manually operate the Fifth Wheel Plate and Release Handle to better understand the locking action. A better working knowledge of the plate will help prevent accidental dropping of your trailer due to incorrect hitching.

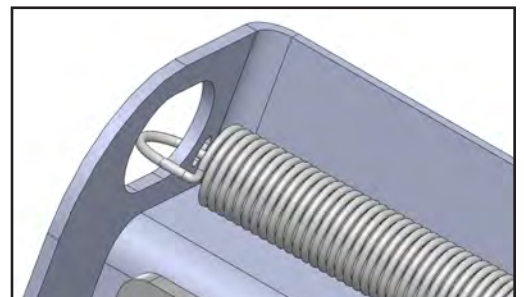

Also, it is imperative that you study and adhere to the Maintenance procedures provided in the Owners Manual.

MOUNTING KIT EXPLODED VIEW

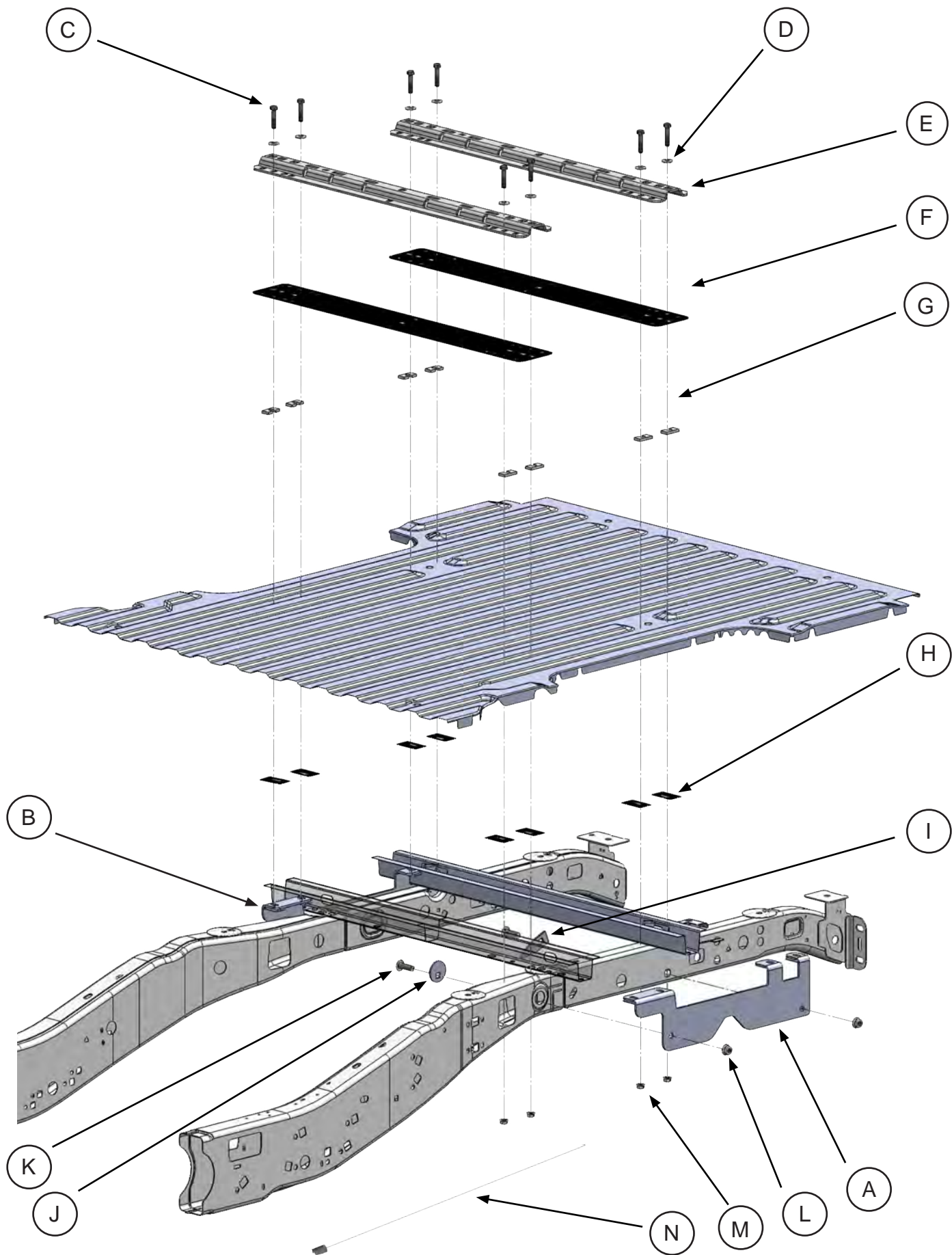

MOUNTING KIT PARTS LIST

#2760 CUSTOM MOUNTING KIT

| item | description | part no. | qty. | material |
|------|---------------------------------|----------|------|---|
| A | DRIVER SIDE MOUNTING BRACKET | 276101 | 1 | |
| B | PASSENGER SIDE MOUNTING BRACKET | 276102 | 1 | |
| C | BASE RAIL MOUNTING BOLTS | 98010178 | 8 | 1/2"-13 X 2-1/4" HHCS GRD 5 |
| D | 1/2" CONICAL WASHER | 98200172 | 8 | 1/2" EXT. TOOTH CONICAL WASHER |
| E | BASE RAIL KIT | 2719 | 1 | TWO INDUSTRY STANDARD BASE RAILS |
| F | BASE RAIL PLASTIC SPACER | 27610003 | 2 | |
| G | SLOTTED ALUMINUM BED SHIM | 27610004 | 8 | 5/16" SLOTTED ALUMINUM BED SHIM |
| H | PLASTIC WASHER | 27610005 | 8 | 1/2" PLASTIC WASHER |
| I | ANGULAR BOLT WASHER | 27610002 | 2 | |
| J | CIRCULAR BOLT WASHER | 27610001 | 2 | |
| K | FRAME BOLT | 98050131 | 4 | 5/8" X 2" CARRIAGE BOLT GRD 5 |
| L | 5/8" FRAME FLANGE NUT | 98150200 | 4 | 5/8"-11 SERRATED FLANGE NUT ZINC PLATED |
| M | 1/2" BASE RAIL FLANGE NUT | 98150201 | 8 | 1/2"-13 SERRATED FLANGE NUT ZINC PLATED |
| N | 5/8" BOLT LEADER | 98340198 | 1 | 5/8" - 11 BOLT LEADER |

LAYOUT TEMPLATE

| description | part no. | qty. | material |
|---------------------|----------|------|----------------------|
| LAYOUT BED TEMPLATE | 27200000 | 1 | ITEM SOLD SEPARATELY |

TRUCK PREPARATION

1. Block vehicle wheels. Some vehicles may require you to raise the rear of the truck to install the mounting brackets on the truck frame.
2. You may wish to remove the wheels to give yourself greater working room.

MARKING THE TRUCK BED FOR DRILLING

LAYOUT METHOD

If you purchased an installation template, please proceed to "TEMPLATE METHOD". *Templates are sold separately.*

1. Referencing "Truck Bed Dimension Table" below, measure and mark from the back of the bed forward, the values for "A." Do this at any point on both sides of the bed and draw a line across the bed from mark to mark.
2. Find the centerline of the bed.
3. Draw a line down the middle of the bed from front-to-rear.
4. Starting at "A," measure from the end of the bed back to the first bolt hole on the base rail (row 4) and mark the bed.
5. Measure the distance of "C" from the centerline of the bed in both directions.
6. Continue working toward the cab, marking the center holes of each remaining bolt locations.

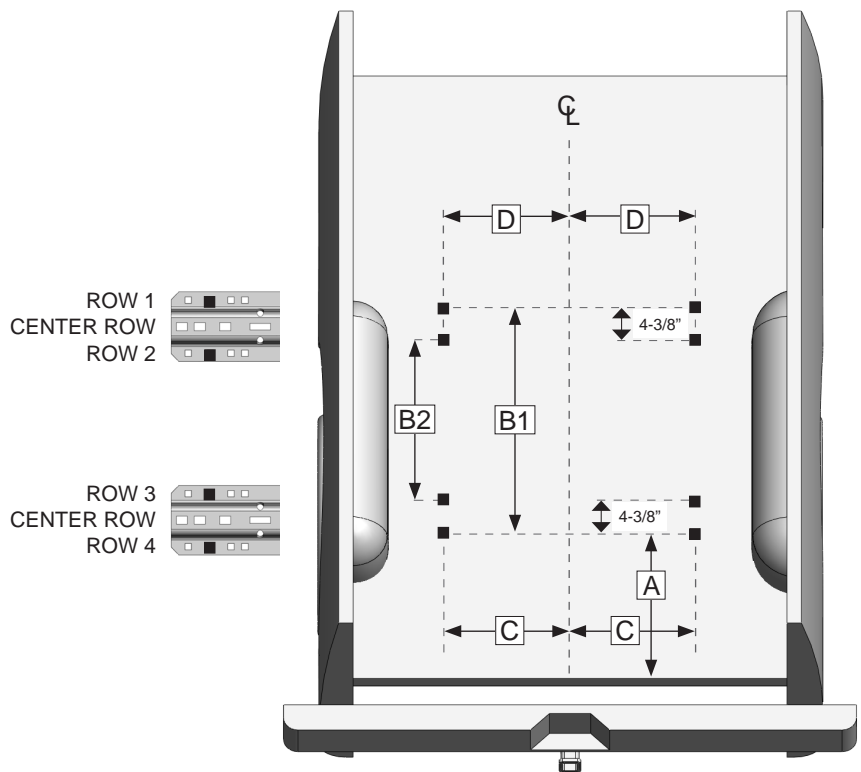

| TRUCK BED DIMENSION TABLE | | | | | |
|---------------------------|----------|-----------|-----------------|---------|----------------|
| LAYOUT METHOD | | | TEMPLATE METHOD | | |
| "A" | "B1" | "B2" | "C" | "X" | Template part# |
| 29-5/16" | 26-5/16" | 17-11/16" | 18-9/16" | 28-5/8" | 27200000 |

TEMPLATE METHOD

1. Lay the template in the truck bed, centering it from side-to-side, and parallel to the end of the truck bed using the dimension "X" listed in "Truck Bed Dimension Table."
2. Mark the 8 holes, while making sure the template does not move.

INSTALLATION TIPS: The *TEMPLATE* should be orientated as shown in the drawing below. To avoid drilling holes in error from out of tolerance bed-to-frame dimensions, mark the hole locations as lightly as possible if a center or transfer punch is used. Then use a very small diameter drill bit to drill one location on either side of bed. Place the *Mounting Brackets* against the frame to determine the correctness of the bed hole locations relative to the pre-punched holes in the *Mounting Bracket* and existing frame holes. Adjust the template pattern relative to the end of the bed, as necessary, to move the bed holes nearer the center of the mounting bracket holes. Note also, the information etched into the template — the direction of the cab, the template number and the revision date. As one last measure, the template has a tendency to move when placed on the slick paint of new truck beds, and it may be helpful to place a small piece of *NON-SKID* matting, such as "SCOOT-GARD"™ or simply use duct tape on each corner to help keep the template from moving.

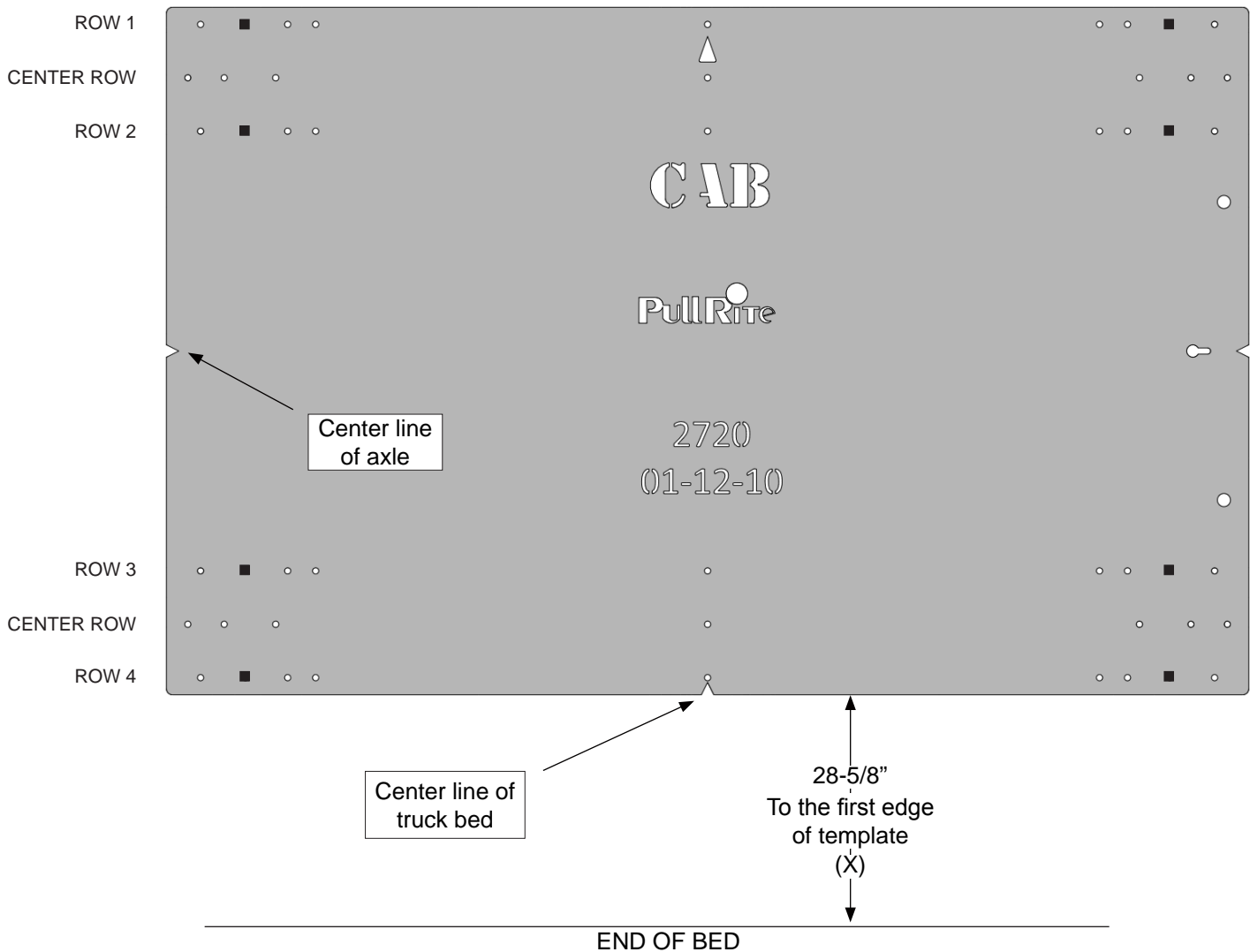

INSTALLATION

PART 1 — BRACKET PLACEMENT & BED HOLE LOCATIONS

Since most truck beds are not installed square to the frame or are the same distance from the back of the cab, the installer will need to make sure the bed holes line up properly with the center of each mounting bolt hole.

The basic steps in this section are as follows:

- Layout the bed holes
- Drill the first pilot hole in the bed
- Check centering
- Adjust the bed hole layout if necessary
- Drill the second pilot hole and check centering to ensure bed hole locations are square to the frame; adjust as needed
- Drill remaining pilot holes in the bed; check centering

Detailed Installation Instructions

NOTE: Some truck beds are not installed square on their frame by the manufacturer. To ensure your pilot holes are aligned properly, it is important that you use the measurements provided only as a starting point and make adjustments as needed. Once the rear driver side pilot hole is centered front-to-back and within the range of the slotted hole, side-to-side, you will use this hole as a point of reference for all remaining pilot hole adjustments. If you are using the Template Method, simply use the properly drilled hole as a pivot point to square the remaining holes to the frame. If you are using the Layout Method, you may accomplish the same thing by using a framing square and straight edge.

1. This is a no-drill application--there are existing holes in the frame to use as reference.
 2. Position the Driver Side Mounting Bracket on the frame where the bracket seats between the center cross sills of the truck bed, using the rearward hole on the Mounting Bracket as a reference point (*below*). Center the rear hole to the hole in the truck's frame prior to drilling.
 3. Drill the first 1/16" pilot hole through the truck bed over the *rear* slotted bolt hole of the Driver Side Mounting Bracket where you made the mark during the "Marking Bed for Drilling."
- Tip:** Cover the top of the Mounting Post hole of each mounting bracket with masking tape then when the small pilot holes are drilled in the bed, the bit will also pierce the tape allowing you to accurately see the relative location of the bed holes to the pilot holes.
4. Clamp in place to determine if your bed layout marks are square to the frame, making sure the bracket is tight against the frame (some mounting brackets may have a slight warp due to the metal characteristics during the welding process).
 5. Once the rear pilot hole is centered front-to-back and within the range of the slotted hole, side-to-side, drill a 1/16" pilot hole for the *front* slotted bolt hole of the Driver Side Mounting Bracket.
 6. Repeat Steps 2-5 for the Passenger Side Mounting Bracket.
 7. Remove both mounting brackets from the frame and drill out all pilot holes with an appropriate size drill bit.

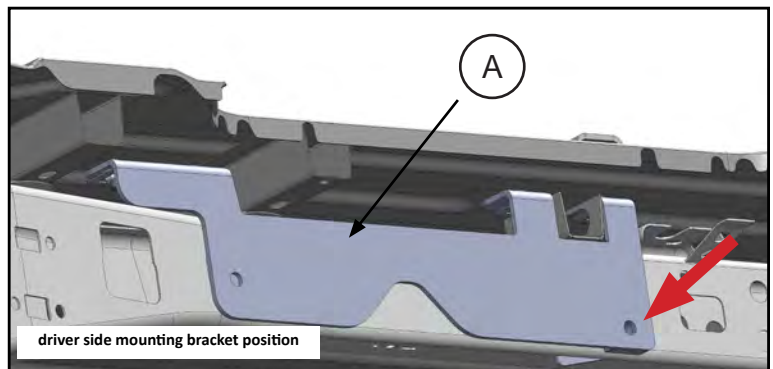

TIP: Truck beds are much easier to drill using a step drill (*right*) and a larger bed hole, as large as 3/4" will make the installation much easier.



INSTALLATION

PART 2 — BRACKET INSTALLATION

1. Examine the Mounting Brackets and note that there is a tab located just below the slotted bolt hole in the top plate of the Mounting Bracket (see right). The purpose of this tab is to assist you in holding the 1/2" Flange Nut {M} in place. To install, pry the "tab" down far enough so that a Flange Nut can be inserted, then push the "tab" back up into position. The Flange Nut should be able to slide in and out while the "tab" holds the nut in place. When fastening the Base Rails to the Mounting Brackets, the Flange Nut can easily be positioned under the square hole in the Base Rail using a pen or other small tool. When tightening the Base Rail Bolts with an impact gun, start slowly as the "tab" may otherwise "strip out."
2. Using a clamp, place the driver side mounting bracket flush against the side of the frame, checking that the slotted holes in the bracket are centered with the pilot holes in the bed of the truck and the rearward hole in the mounting bracket is centered with the hole in the truck frame.
3. Install both Angular {I} and Circular {J} Bolt Washers onto the four Frame Bolts {K}. With washers installed, these bolts become anti-rotation fasteners.
4. Thread the front Circular Bolt Washer and bolt onto the supplied Bolt Leader {N}.

TIP: Thread the nut on and off the bolt to ensure the nut will fit easily once the bolt is in place.



5. Remove the clamp from the Mounting Bracket.
6. Insert the bolt leader through the center, obround relief hole on the inside of the truck frame (right). As the leader emerges through the hole in the frame, pull the corner of the Mounting Bracket away from the frame to help you see the Circular Washer's installation in the embossment of the hole (see below).

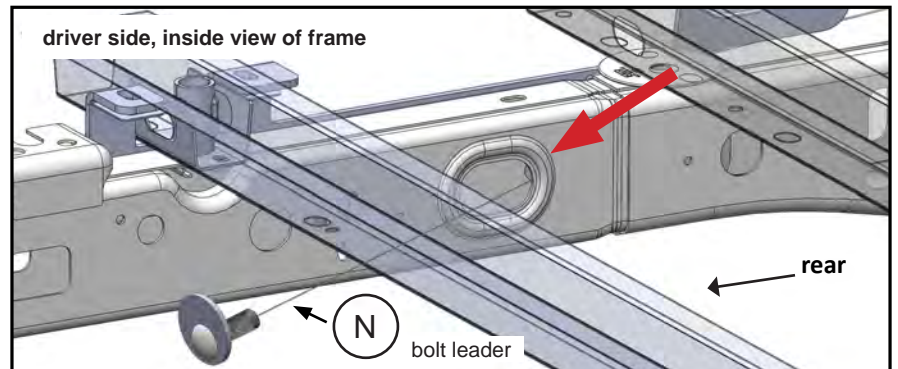

IMPORTANT: We have designed the Circular Washer for both front bolt locations to fit in the embossed/concave shaped holes in the truck frame. Be sure when you seat the the bolt and washer in the hole, that the hole on the Circular Washer is oriented in the *bottom* position as seen in the illustration below.

7. Pull the bolt leader through frame and bracket, and remove the bolt leader.
8. Install the 5/8" Flange Nut {L} to the bolt and tighten by hand.
9. Repeat Steps 6-8 for the rearward hole in the Mounting Bracket. Take note of each type of bolt and washer and their proper position— angular anti-rotation bolts toward the rear, Circular toward the cab.

10. Repeat Steps 4-9 for the Passenger Side Mounting Bracket.

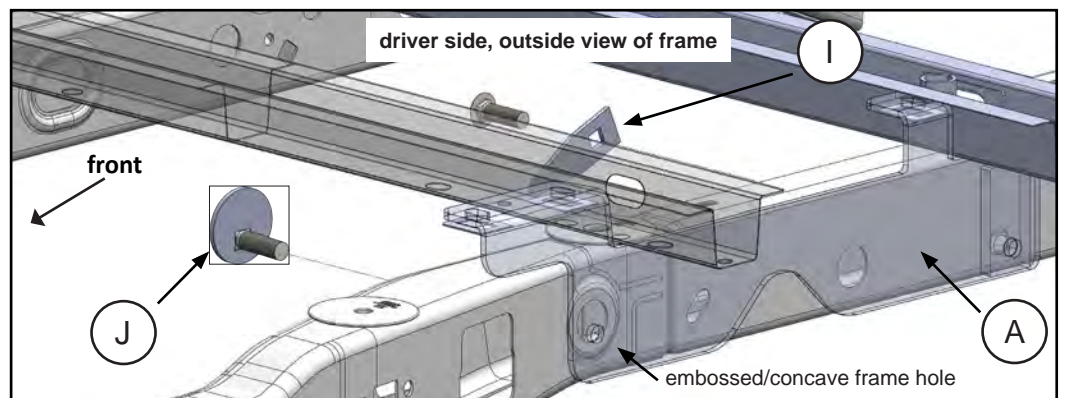

INSTALLATION

PART 3 — SHIMMING THE BED

IMPORTANT: Steel parts cannot be installed directly against aluminum as it will cause corrosion. We have provided Plastic Washers {H}, Bed Rail Plastic Spacers {F}, and aluminum Bed Shims {G} to be installed against Ford's new aluminum truck bed. View the part configuration to the right carefully, making sure that no steel parts are in direct contact with aluminum.

1. To prevent "crushing" of the corrugated truck bed, we provide aluminum Slotted Bed Shims {G} to be installed above and/or below the truck bed where necessary. Not all truck beds are installed exactly the same when manufactured, so it is necessary for you to determine where to place your shims, relative to the bolt locations (see "Layout Method").
2. If you find that a bolt hole location is located over a bed channel, you will need to use a Slotted Bed Shim to fill the space so it is even with the top of the bed. Conversely, do the same if the channel is located on the *underside* of the bed if necessary. If you find yourself shimming the top side of the bed, be sure you still install the Plastic Washers {H} between the aluminum bed and the steel mounting bracket.
3. Base Rail Mounting Bolts {C} pass through all components and into the previously installed flange nuts in each Mounting Bracket.

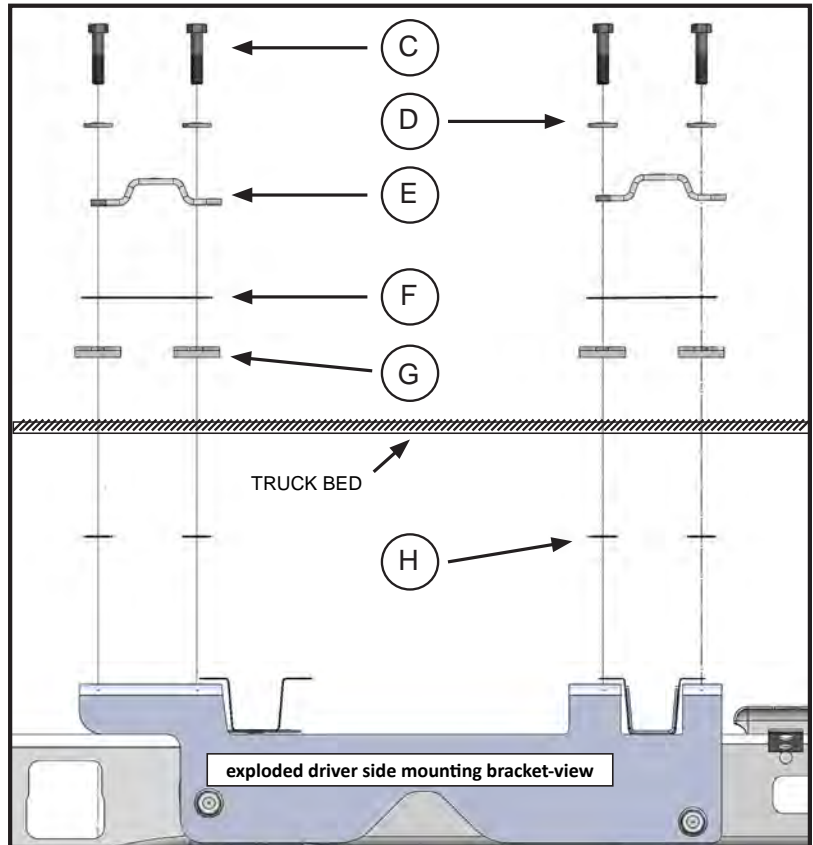

PART 4 — FINAL INSTALLATION PROCEDURES

1. Set the hitch on the Industry Standard Rails by centering the tabs on the bottom of the hitch into the slots on the rails.
2. Install the hitch pins through the side of the base rails to secure the hitch assembly to the base rails using the supplied pin clips.
3. Make certain the hitch comes on and off without binding prior to completing final torques.
4. Tighten all bolts, including the base rail bolts, according to the Torque Table.

TORQUE TABLE

| | |
|-----------|----------------|
| 3/8" bolt | — 31 ft. lbs. |
| 1/2" bolt | — 75 ft. lbs. |
| 5/8" bolt | — 151 ft. lbs. |
| 3/4" bolt | — 266 ft. lbs. |