



# 2003 - 2012 RAM 2500 - 3500

## 18K Industry Standard SuperRail Custom Mounting Kit

### #2330



#### Industry Standard Super 5<sup>th</sup>

**#1900**

Gross Trailer Weight (Maximum) 16,000 lbs.  
Vertical Load Weight (Max. Pin Weight) 4,000 lbs.

**#2100**

Gross Trailer Weight (Maximum) 20,000 lbs.  
Vertical Load Weight (Max. Pin Weight) 5,000 lbs.

**#2200**

Gross Trailer Weight (Maximum) 24,000 lbs.  
Vertical Load Weight (Max. Pin Weight) 6,000 lbs



#### Industry Standard SuperGlide

**#2700**

Gross Trailer Weight (Maximum) 16,000 lbs.  
Vertical Load Weight (Max. Pin Weight) 4,000 lbs.

**#2900**

Gross Trailer Weight (Maximum) 18,000 lbs.  
Vertical Load Weight (Max. Pin Weight) 4,500 lbs.

**#2300**

Gross Trailer Weight (Maximum) 24,000 lbs.  
Vertical Load Weight (Max. Pin Weight) 6,000 lbs

---

# Installation Instructions

---

## SPECIFICATIONS

- Fits 2003-2012 Ram 2500-3500
- Hitch is located center of the rear axle
- Custom Mounting Bracket Kit (Bracket & Hardware) #2331

# TABLE OF CONTENTS

PLATE ASSEMBLY.....	3
MOUNTING KIT PARTS LIST.....	4
MOUNTING KIT EXPLODED VIEW.....	5
TRUCK PREPARATION.....	6
MARKING THE TRUCK BED FOR DRILLING (Layout Method).....	6
TRUCK BED DIMENSION LAYOUT.....	7
TEMPLATE METHOD .....	9
INSTALLATION.....	10

# PLATE ASSEMBLY

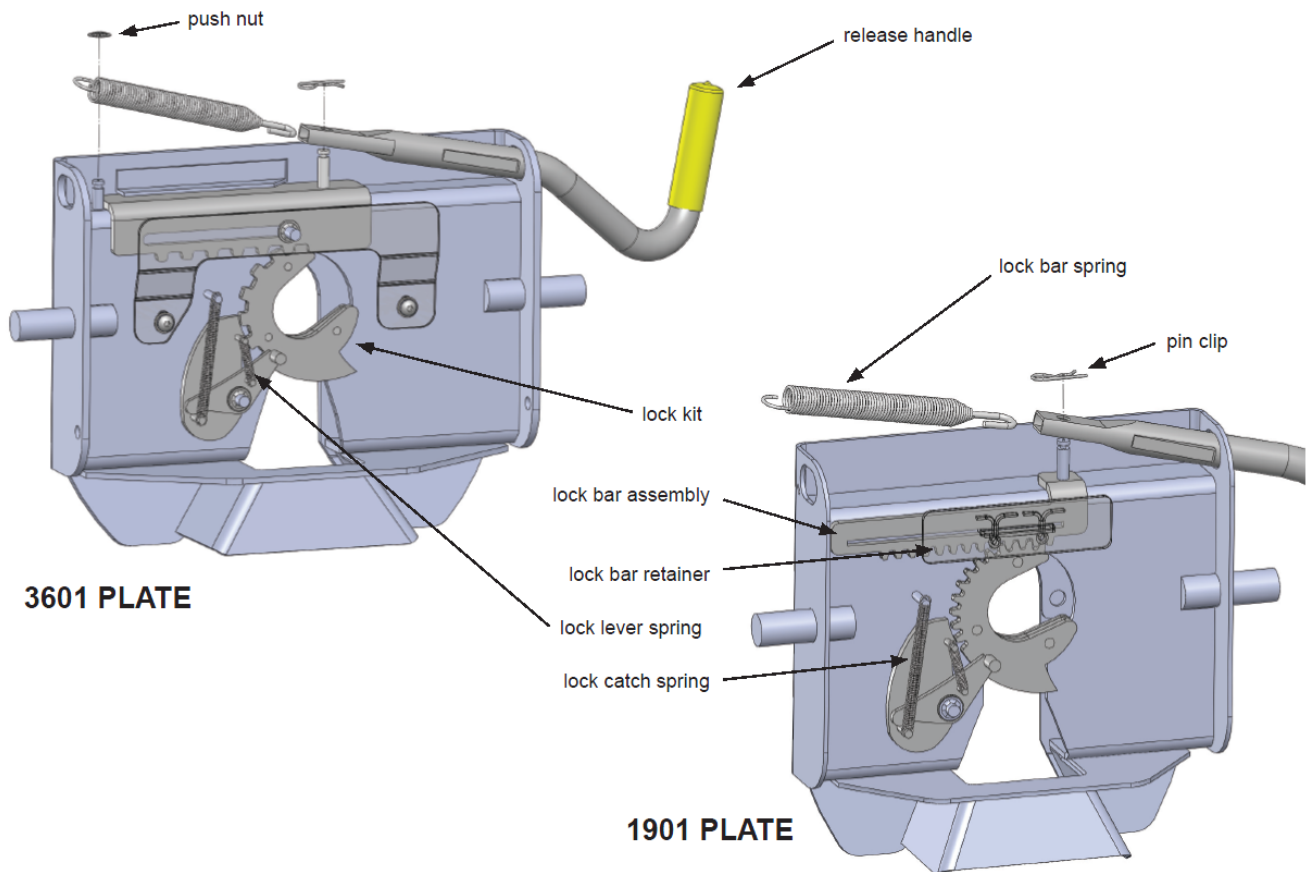

1. Remove the Fifth Wheel Plate from the Rocker arm and place it upside down on a smooth, clean surface.
2. Insert the Release Handle into the obround hole of the plate as seen above.
3. The Lock Bar Spring must be placed inside the handle prior to placing the handle down over the pin of the Lock Bar assembly, "catching" the hook inside the handle around the pin.
4. Push the handle and spring assembly down past the groove in the pin of the Lock Bar assembly, and place one of the Pin Clips in the groove of the pin to fasten.
5. Grip the body of the spring and stretch it far enough over the opposite pin (welded to the plate) and push it down past the groove.
6. Install the Push nut to secure the Lock Bar Spring onto the welded pin.

**NOTE:** The 1901 plate for the #1900 Super 5th does not use a push nut to attach the end of the spring, but rather a slot in the side of the fifth wheel plate located above the obround hole. See illustration to the right.

As a PullRite fifth wheel hitch owner, it is important for you to study and manually operate the Fifth Wheel Plate and Release Handle to better understand the locking action. A better working knowledge of the plate will help prevent accidental dropping of your trailer due to incorrect hitching.

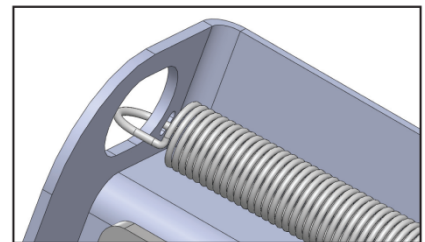

Also, it is imperative that you study and adhere to the Maintenance procedures provided in the Owners Manual.

# MOUNTING KIT PARTS LIST

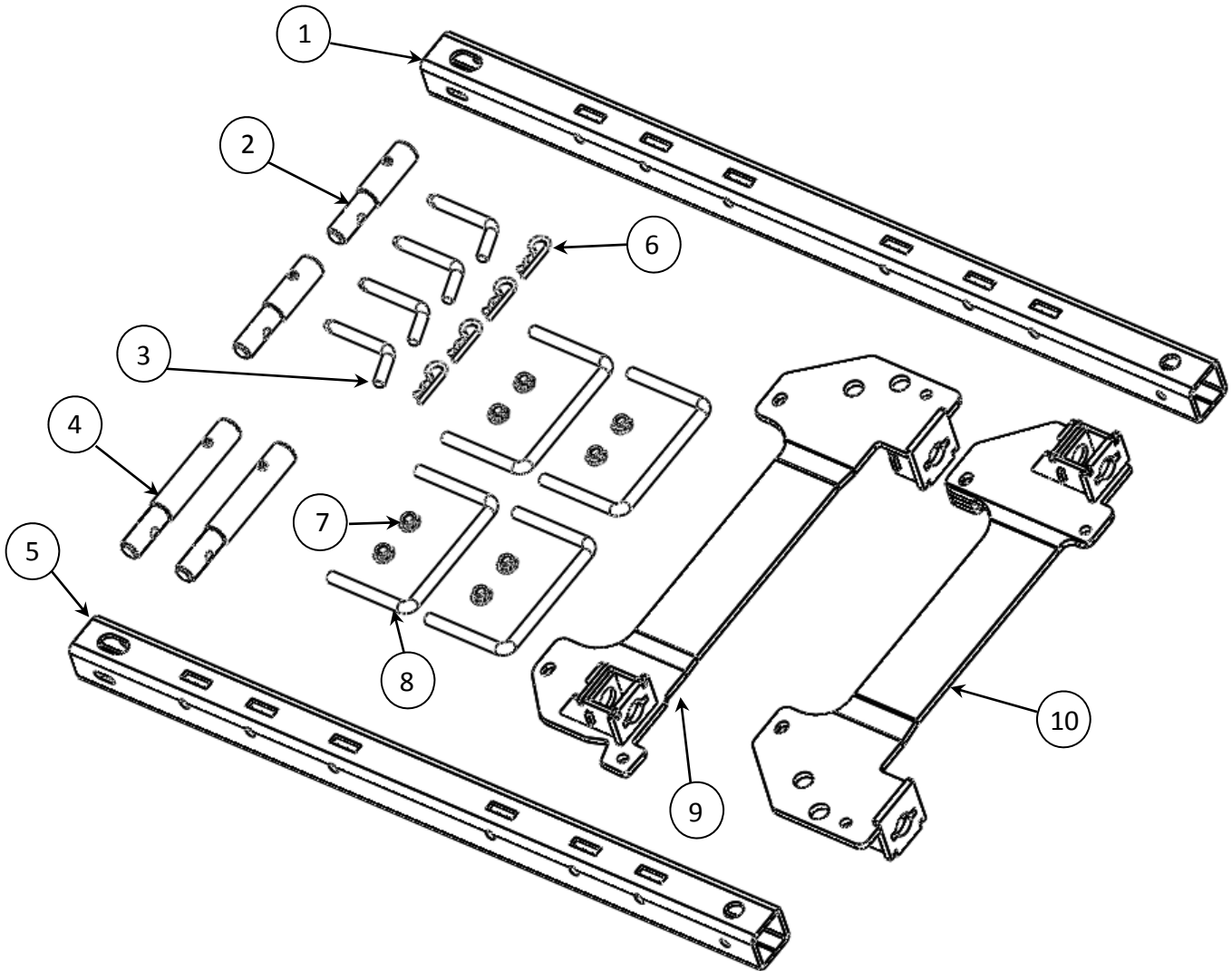

ITEM NO.	PART NUMBER	DESCRIPTION	QTY.
1	23230110	MOUNTING RAIL – 2014 Old Dodge	1
2	232201	MOUNTING POST	2
3	08060001	BASE RAIL RELEASE PIN	4
4	232207	MOUNTING POST	2
5	23230109	MOUNTING RAIL – 2014 Old Dodge	1
6	98410143	PIN CLIP	4
7	98150201	½" – 13 SERRATED FLANGE NUT	8
8	98150184	½" – 13 U- BOLT	4
9	233102	RH (PASSENGER'S SIDE) BRACKET ASSEMBLY – 2003-12 Dodge	1
10	233101	LH (DRIVER'S SIDE) BRACKET ASSEMBLY – 2003-12 Dodge	1

# MOUNTING KIT EXPLODED VIEW

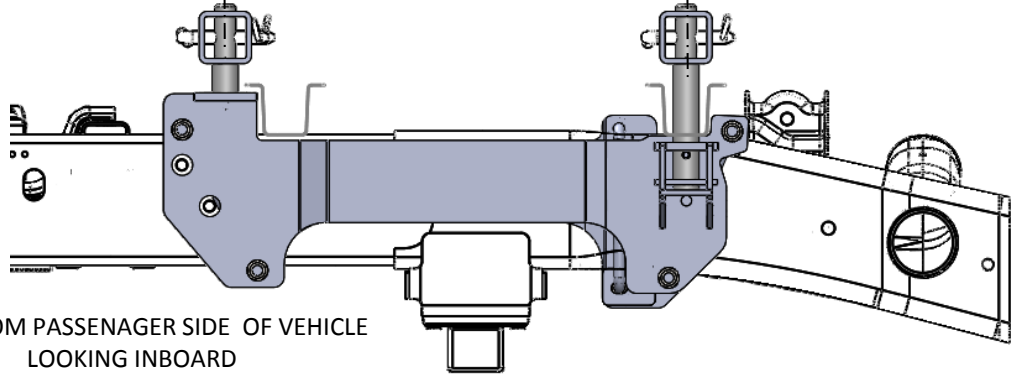
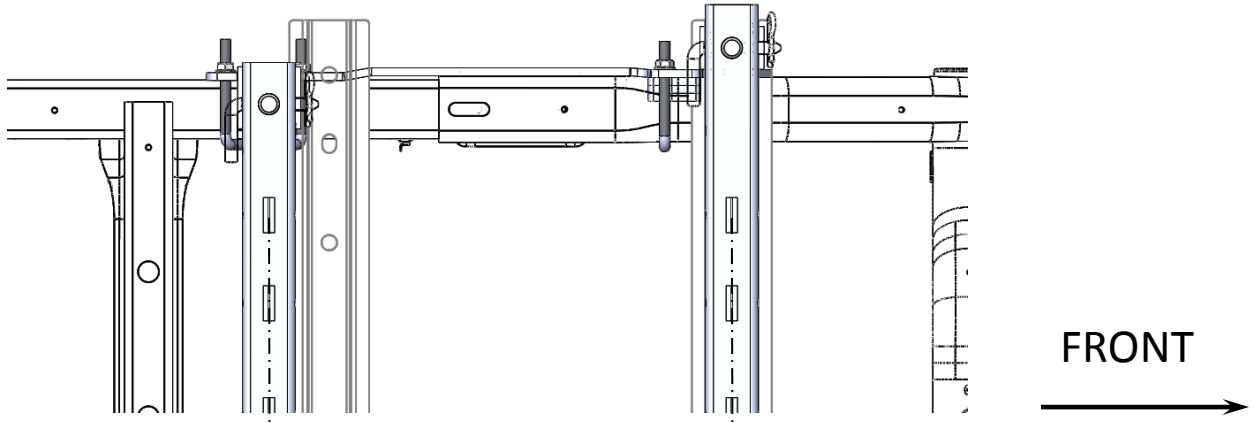
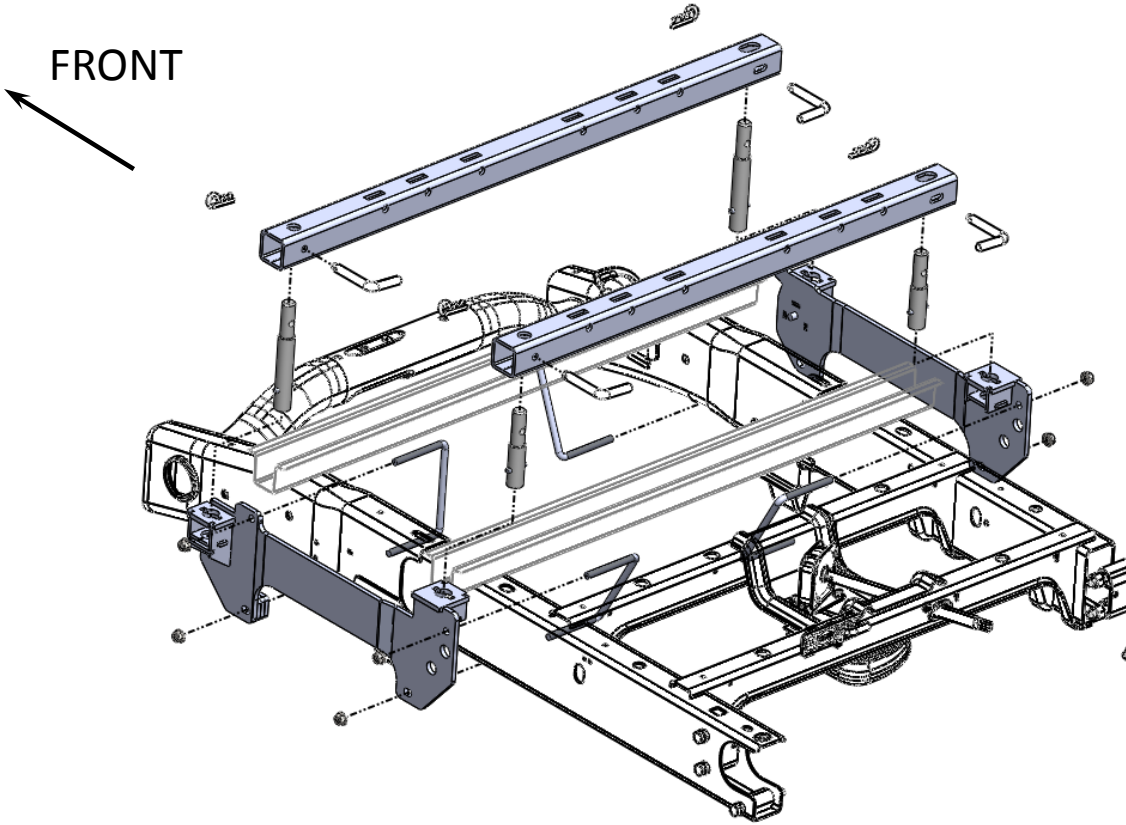

# TRUCK PREPARATION

1. Block vehicle wheels. Some vehicles may require you to raise the rear of the truck to install the mounting brackets on the truck frame.
2. You may wish to remove the wheels to give yourself greater working room.
3. Carefully remove the plastic inner wheel well guards on both sides of the vehicle (*not applicable to some models*).
4. Removal of the spare tire may be required on some models. This will allow easy access to the inside of the truck frame. The fender support at the front of the wheel well may also need to be removed, in order to access the front hole location.

## MARKING THE TRUCK BED FOR DRILLING

### LAYOUT METHOD

If you purchased an installation template, please proceed to "TEMPLATE METHOD". *Templates are sold separately.*

1. Referencing "Truck Bed Dimension Layout" and the illustration below, measure and mark from the back of the bed forward, the value for each Row. Do this at any point on *both* sides of the bed and chalk a line across the bed from mark to mark.
2. Find the centerline of the bed.
3. Chalk a line down the middle of the bed from front-to-rear.
4. The intersection of the **REARWARD ROW** and the **Centerline of Bed** is the center line of the mounting rail location. Starting at this intersection, measure the cross car distance in both directions to find the remaining post hole locations.
5. Continue working toward the cab, marking the distance of the other holes located on the Center Row.

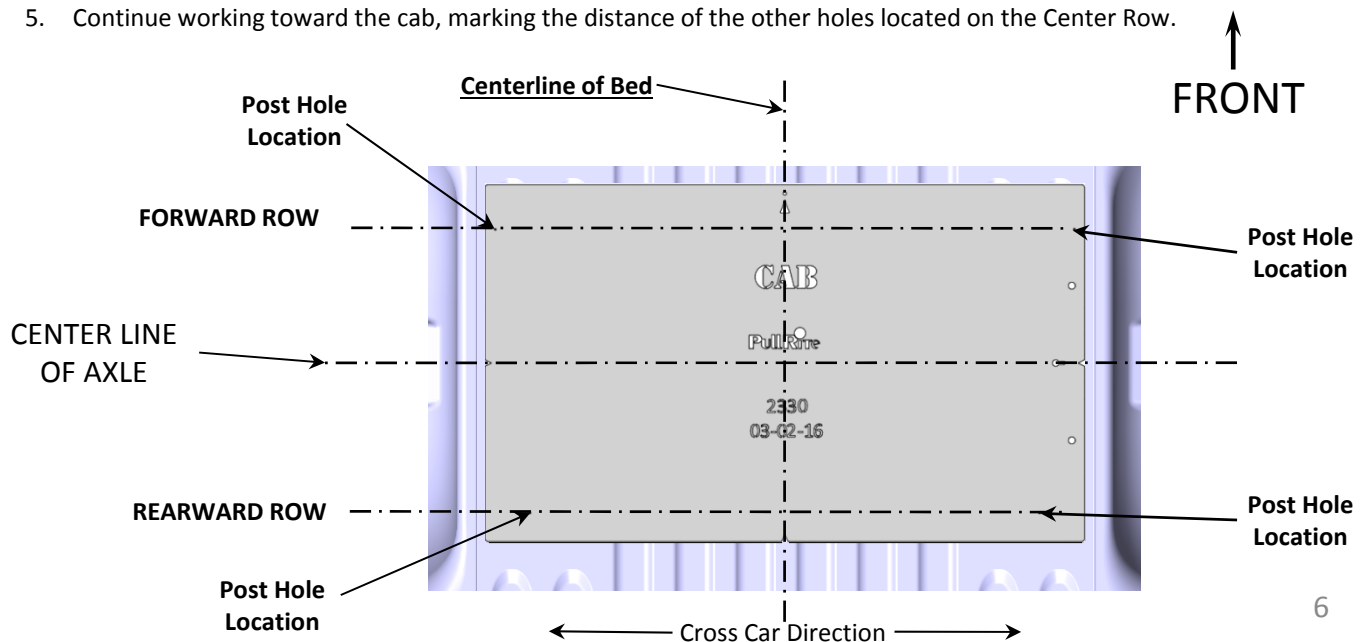

# TRUCK BED DIMENSION LAYOUT – 6 ft. Bed

If you purchased an installation template, please proceed to "TEMPLATE METHOD". (Templates are sold separately.)

1. Referencing Truck Bed Dimension Figure below, measure and mark from the back of the bed forward, the value for the location for the mounting post holes. Do this at any point on *both* sides of the bed and caulk a line across the bed from mark to mark.
2. Find the CENTER LINE OF THE BED.
3. Chalk a line down the middle of the bed from front-to-rear.
4. The intersection between the "Rearward Row" and  $19\frac{3}{4}$ " from the centerline of the bed is the center hole location of the post hole. Starting at this intersection, measure the distance,  $39.5$ ", in the opposite direction to find the remaining post hole location.
5. Continue working toward the cab, marking the distance " $22$ " as the distance between both rows of the mounting base rail. The intersection between the "Forward Row" and  $22\frac{7}{16}$ " from the centerline of the bed is the center hole location of the post hole. Starting at this intersection, measure the distance,  $44\frac{7}{8}$ ", in the opposite direction to find the remaining post hole location.

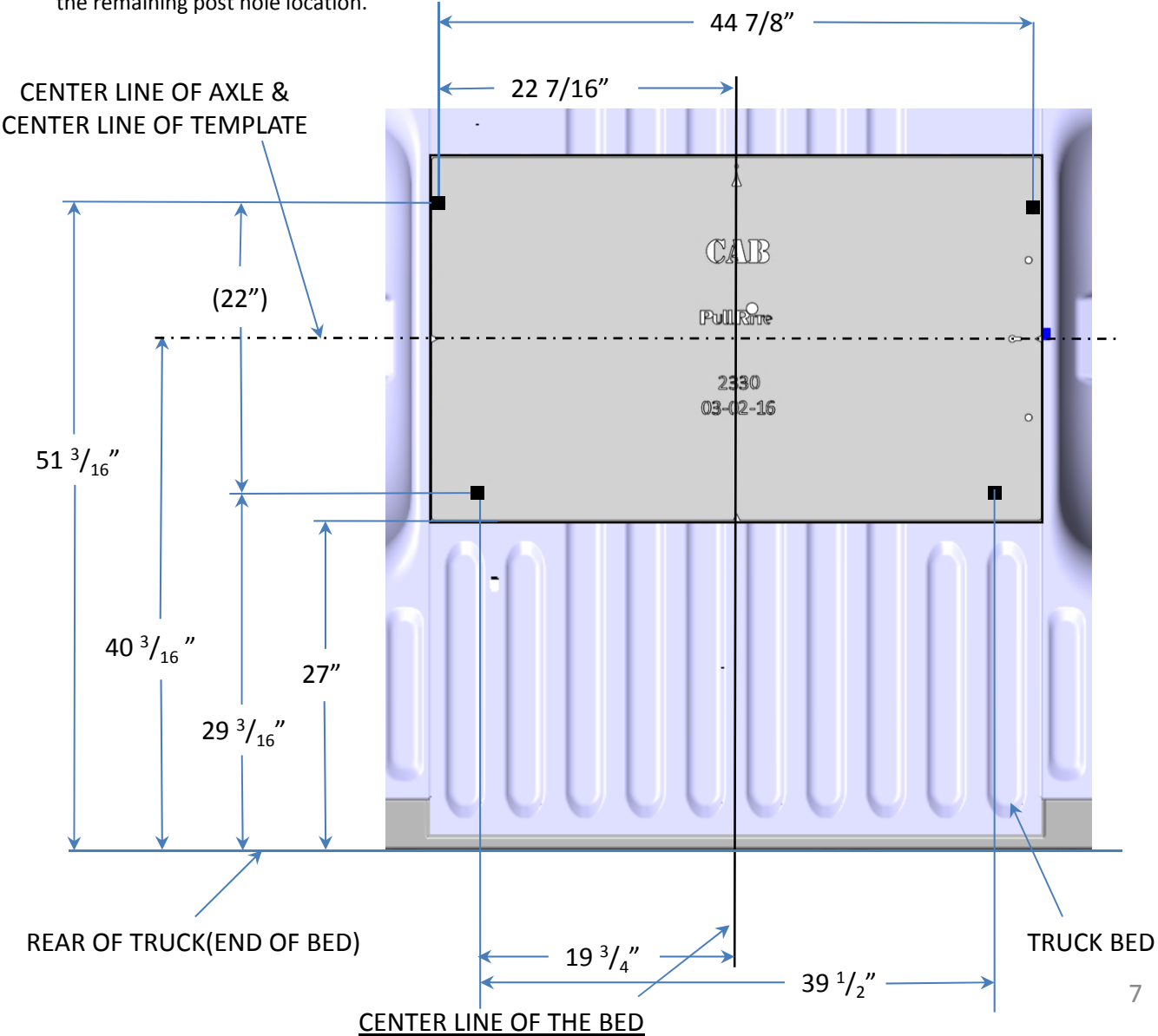

# TRUCK BED DIMENSION LAYOUT – 8 ft. Bed

If you purchased an installation template, please proceed to "TEMPLATE METHOD". (*Templates are sold separately.*)

1. Referencing Truck Bed Dimension Figure below, measure and mark from the back of the bed forward, the value for the location for the mounting post holes. Do this at any point on *both* sides of the bed and caulk a line across the bed from mark to mark.
2. Find the CENTER LINE OF THE BED.
3. Chalk a line down the middle of the bed from front-to-rear.
4. The intersection between the "Rearward Row" and  $19\frac{3}{4}$ " from the centerline of the bed is the center hole location of the post hole. Starting at this intersection, measure the distance,  $39.5$ ", in the opposite direction to find the remaining post hole location.
5. Continue working toward the cab, marking the distance " $22$ " as the distance between both rows of the mounting base rail. The intersection between the "Forward Row" and  $22\frac{7}{16}$ " from the centerline of the bed is the center hole location of the post hole. Starting at this intersection, measure the distance,  $44\frac{7}{8}$ ", in the opposite direction to find the remaining post hole location.

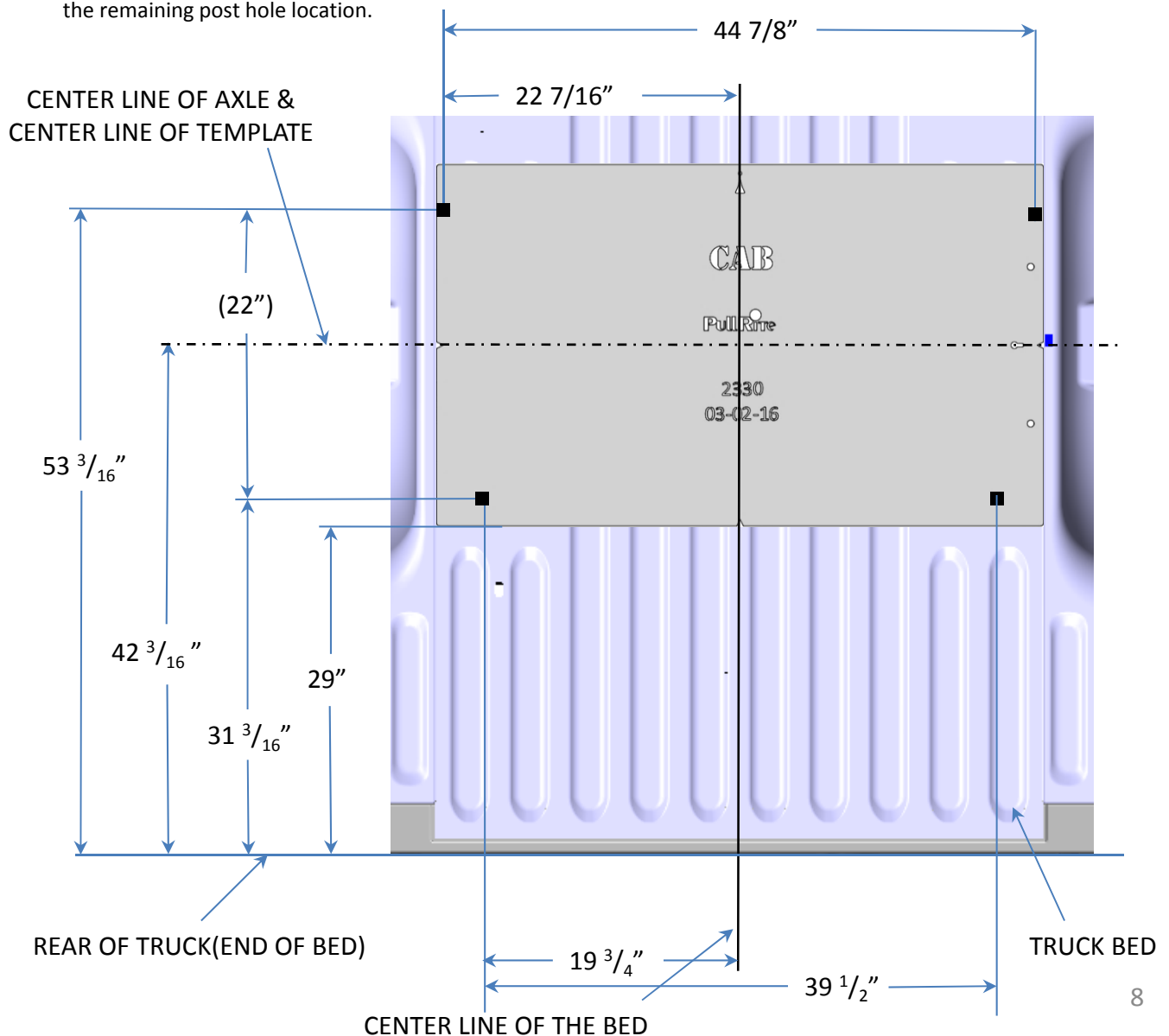

# TEMPLATE METHOD

1. Lay the template in the truck bed, centering it from side-to-side, and parallel to the end of the truck bed using the dimension "X" listed in the figure below.
2. Mark the 4 holes, while making sure the template does not move.

**INSTALLATION TIPS:** The TEMPLATE should be orientated as shown in the drawing below. To avoid drilling holes in error from out of tolerance bed-to-frame dimensions, mark the hole locations as lightly as possible if a center or transfer punch is used. Then use a very small diameter drill bit to drill one location on either side of bed. Place the Mounting Brackets against the frame to determine the correctness of the bed hole locations relative to the prepunched holes in the Mounting Bracket and existing frame holes. Adjust the template pattern relative to the end of the bed, as necessary, to move the bed holes nearer the center of the mounting bracket holes. Note also, the information etched into the template — the direction of the cab, the template number and the revision date. As one last measure, the template has a tendency to move when placed on the slick paint of new truck beds, and it may be helpful to place a small piece of NON-SKID matting, such as "SCOOT-GARD"™ or simply use duct tape on each corner to help keep the template from moving.

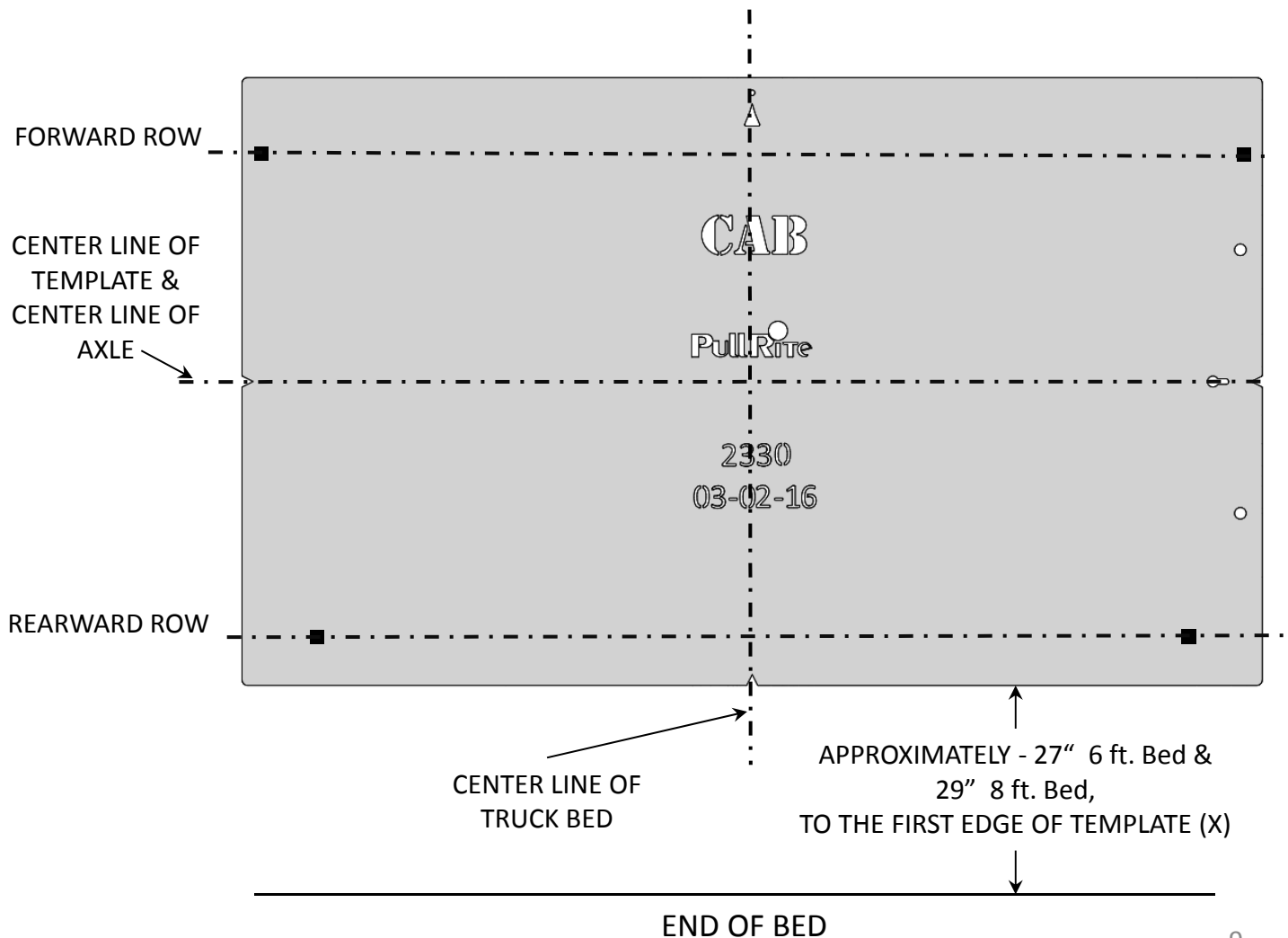

# INSTALLATION

## BRACKET PLACEMENT & BED HOLE LOCATIONS

Since most truck beds are not installed square to the frame or are the same distance from the back of the cab, the installer will need to make sure the bed holes line up properly with the center of each mounting post hole.

The basic steps in this section are as follows:

- Layout the bed holes
- Drill the first pilot hole in the bed
- Check centering (Clamp Side Brackets onto chassis)
- Adjust the bed hole layout, if necessary
- Drill the second pilot hole and check centering to ensure bed hole locations are square to the frame; adjust as needed
- Drill remaining pilot holes in the bed; check centering
- Remove brackets & increase bed holes for posts
- Reinstall brackets, post, and mounting rails
- Install hitch

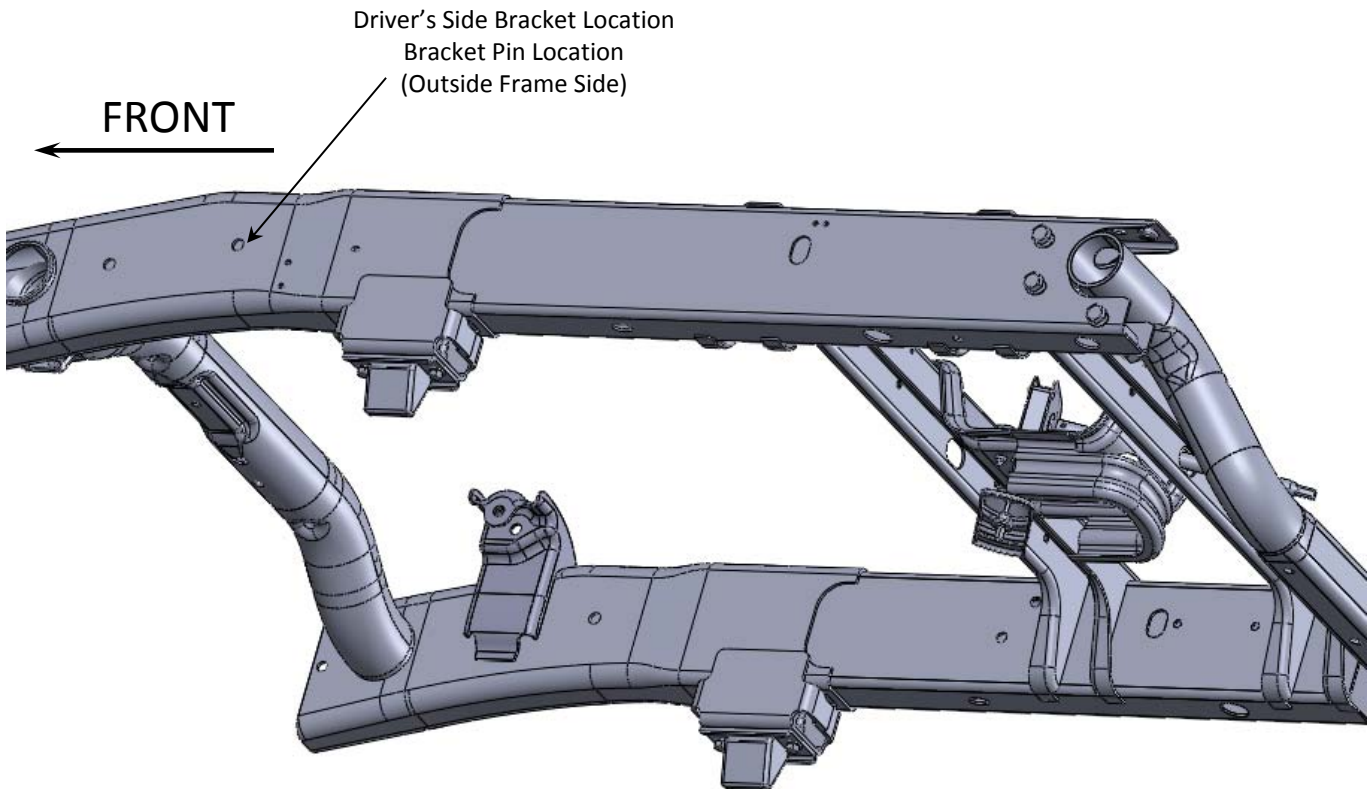

# INSTALLATION

**WARNING:** Prior to drilling any holes, be sure to check the inside of the frame to guard against drilling into the fuel tank, wiring, brake lines or fuel modules.

**NOTE:** Some truck beds are not installed square to the frame by the manufacturer. To ensure your pilot holes are aligned properly, it is important that you use the measurements provided only as a starting point and make adjustments to square the remaining holes to the frame. If you are using the Layout Method, you may accomplish the same thing by using a framing square and straight edge. Once the rear driver side pilot hole is centered, you will use this hole as a point of reference for all remaining pilot hole adjustments. If you are using the Template Method, simply use the properly drilled hole as a pivot.

1. (Optional) - Apply clear tape to the top of each side bracket post receiver. Tape will allow checking of the hole centering when you drill the bed (Mounting Post) holes.
2. Layout the Industry Standard Rail mounting holes. (See "MARKING THE TRUCK BED FOR DRILLING.")
3. Double check measurement before starting the next steps.

**WARNING:** Prior to drilling any holes, be sure to check the inside of the frame to guard against drilling into the fuel tank, wiring, brake lines or fuel modules.

4. Drill the first 1/8" pilot hole through the truck bed over the Forward Row where you made the mark during the "MARKING THE TRUCK BED FOR DRILLING." The drilled hole must be centered in the cross-sill. Special Note: If one uses a hand drill one should use a drill guide jig or block to assure the drill bit is perpendicular to the bed.
5. Drill the other three post hole pilot holes.

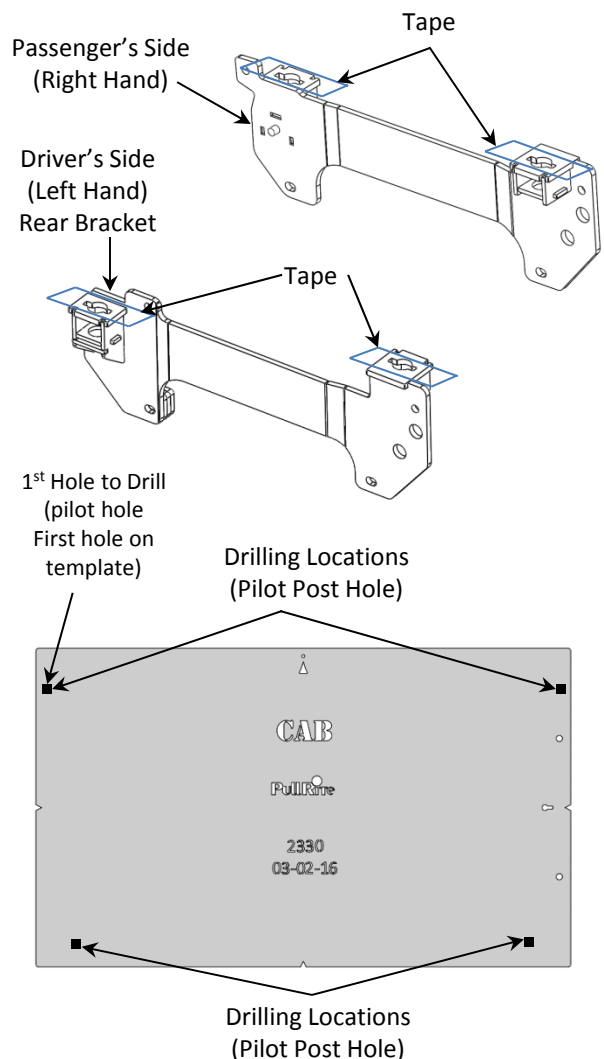

# INSTALLATION

6. Install Driver's Side (Left Hand) Side Bracket.
  - a. Locate the 5/8" dia. hole in the outside face of the chassis that is approximately 10 3/8" in front of the center line of rear axle and about 3 1/8" down from the top of the chassis. This hole will accept the 1/2" diameter pin that is welded to the side bracket. Lift the Driver's Side Bracket up into position making sure the 1/2" pin is placed into the 5/8" chassis hole, noted above. Also, center the post holder opening with the cross-sill and pilot hole that were drilled for the post. If working by yourself, use a quick clamp to hold the bracket into position.
  - b. Take (1) 1/2" - 13 U-Bolt and Lock Nut and align the U-Bolt with the front hole and front slot in the side bracket. Starting on the inside of the frame. Place the U-Bolt on the inside of the frame having the threads pointing outboard. Carefully route the U-Bolt around the brake and fuel lines so that the U-Bolt sits on the frame and not crushing the fuel or brake lines. Loosely secure the U-Bolt with the Lock Nuts.
  - c. Take another (1) 1/2" - 13 U-Bolt and Lock Nut and align the U-Bolt with rear hole and rear slot in the side bracket. Starting on the inside of the frame. Place the U-Bolt on the inside of the frame having the threads pointing outboard. Loosely secure the U-Bolt with Lock Nuts.
  - d. Check alignment of the drilled hole in the bed and the post holder location. If the pilot hole is not centered in the cross-sill and bracket then the pilot hole needs to be relocated. (To check bracket, keep the drill bit in the pilot hole and check for centering (front-to-back and left-to-right) in the Mounting Post Receiver. Relocate hole; relocate the other holes that were marked during the "MARKING THE TRUCK BED FOR DRILLING" too, if drill bit is not centered. (At this time if the side bracket was taped you can remove side bracket to see where the drill bit pierced the tape at the pilot hole/post hole locations.)
  - e. Once alignment has been checked and repositioned, if needed. Using a hole saw or step drill, increase the truck bed post hole/pilot hole to a minimum of 1 5/8" dia., both the top of bed and cross-sill needs to be increased.

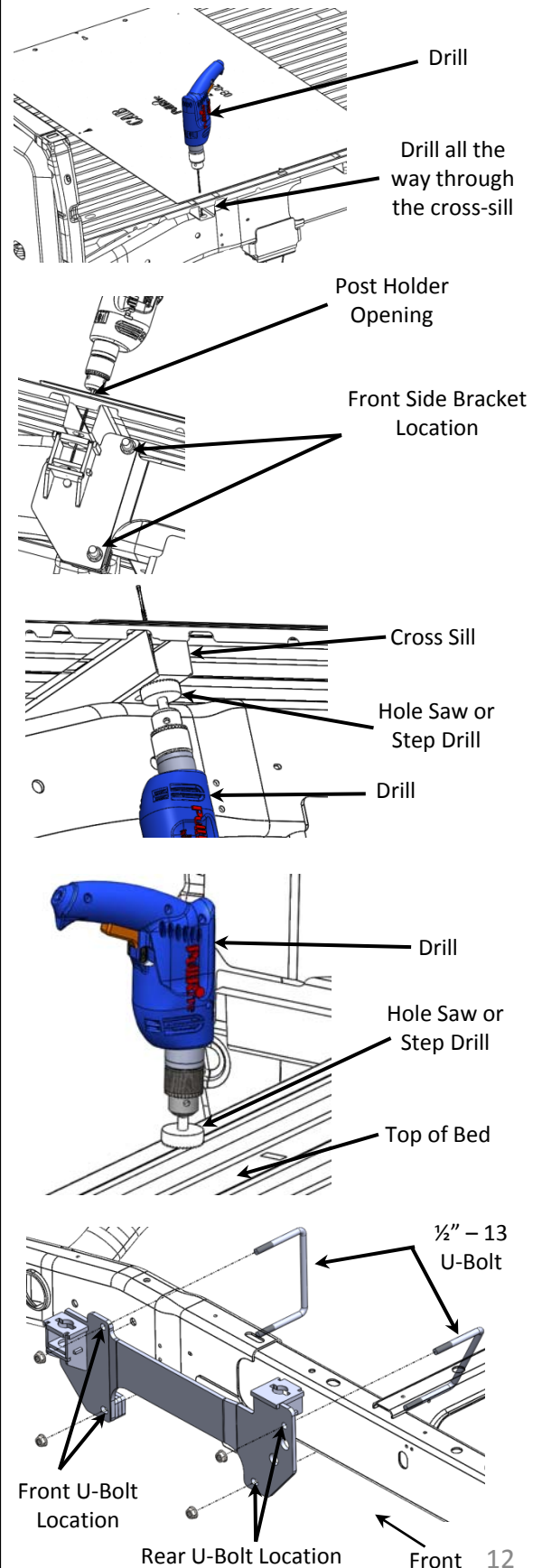

# INSTALLATION

7. Install Passenger's Side (Right Hand) Side Bracket.
  - a. Locate the 5/8" dia. hole in the outside face of the chassis that is approximately 10 3/8" in front of the center line of rear axle and about 3 1/8" down from the top of the chassis. This hole will accept the 1/2" diameter pin that is welded to the side bracket. Lift the Passenger's Side Bracket up into position making sure the 1/2" pin is placed into the 5/8" chassis hole, noted above. Also, center the post holder opening with the cross-sill and pilot hole that were drilled for the post. If working by yourself, use a quick clamp to hold the bracket into position.
  - b. Take (1) 1/2" - 13 U-Bolt and Lock Nut and align the U-Bolt with front hole and front slot in the side bracket. Starting on the inside of the frame. Place the U-Bolt on the inside of the frame having the threads pointing outboard. Loosely secure the U-Bolt with Lock Nuts.
  - c. Take another (1) 1/2" - 13 U-Bolt and Lock Nuts and align the U-Bolt with rear hole and rear slot in the side bracket. Starting on the inside of the frame. Place the U-Bolt on the inside of the frame having the threads pointing outboard. Loosely secure the U-Bolt with Lock Nuts.
  - d. Check alignment of the drilled hole and the post holder location. If the pilot hole is not centered in the cross-sill and bracket then the pilot hole needs to be relocated. (To check bracket, keep the drill bit in the pilot hole and check for centering (front-to-back and left-to-right) in the Mounting Post Receiver. Relocate hole; relocate the other holes that were marked during the "MARKING THE TRUCK BED FOR DRILLING" too, if drill bit is not centered. (At this time if the side bracket was taped you can remove side bracket to see where the drill bit pierced the tape at the pilot hole/post hole locations.)
  - e. Once alignment has been checked and repositioned, if needed. Using a hole saw or step drill, increase the truck bed post hole/pilot hole to a minimum of 1 5/8" dia., both the top of bed and cross-sill needs to be increased.

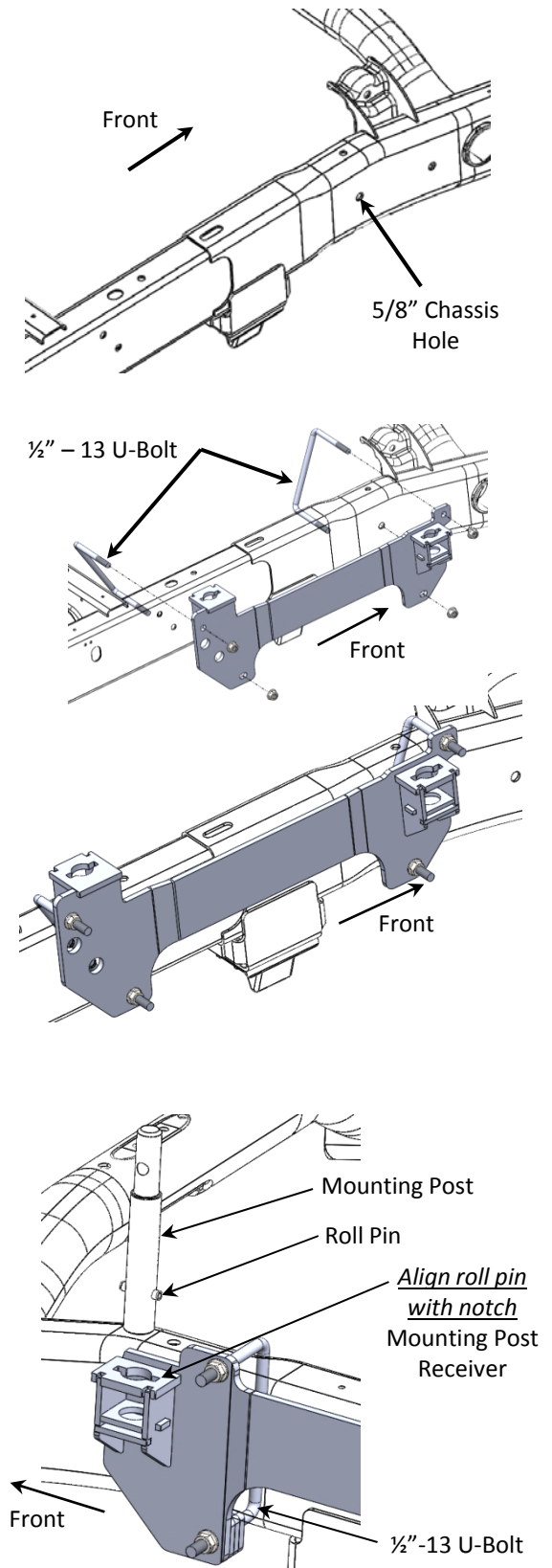

# INSTALLATION

8. Preliminarily tighten all side bracket bolts. Pre-torque all ½"-13 U-Bolts and Nuts to 45 lbs.-ft.
9. Add mounting posts. Align the roll pin that is contained within the post with the notches in the Mounting Post Receiver. Push down and rotate post, 90 degrees, to lock post into place. Place the longer posts into the forward most position.
10. Install Mounting Rails – (2003-2012) Dodge 2500. Place mounting rail over the mounting posts. Lock Mounting Rail into place with pins and clips. Pins must go through both the Mounting Rail and the Mounting Pin and Pins must be captured with Clip. Orient the hole on the mounting rail to the driver's side.
11. Set the hitch on the (Industry Standard) Mounting Rails by centering the tabs/spades on the bottom of the hitch into the slots on the mounting rails. Install the hitch pins through the side of the base rails to secure the hitch assembly to the base rails using the supplied pins & clips. Make certain the hitch comes on and off without binding.
12. Tighten all side bracket bolts. Torque and retorque all ½"-13 Nuts to 75 lbs-ft (tolerance ±3 lbs-ft)

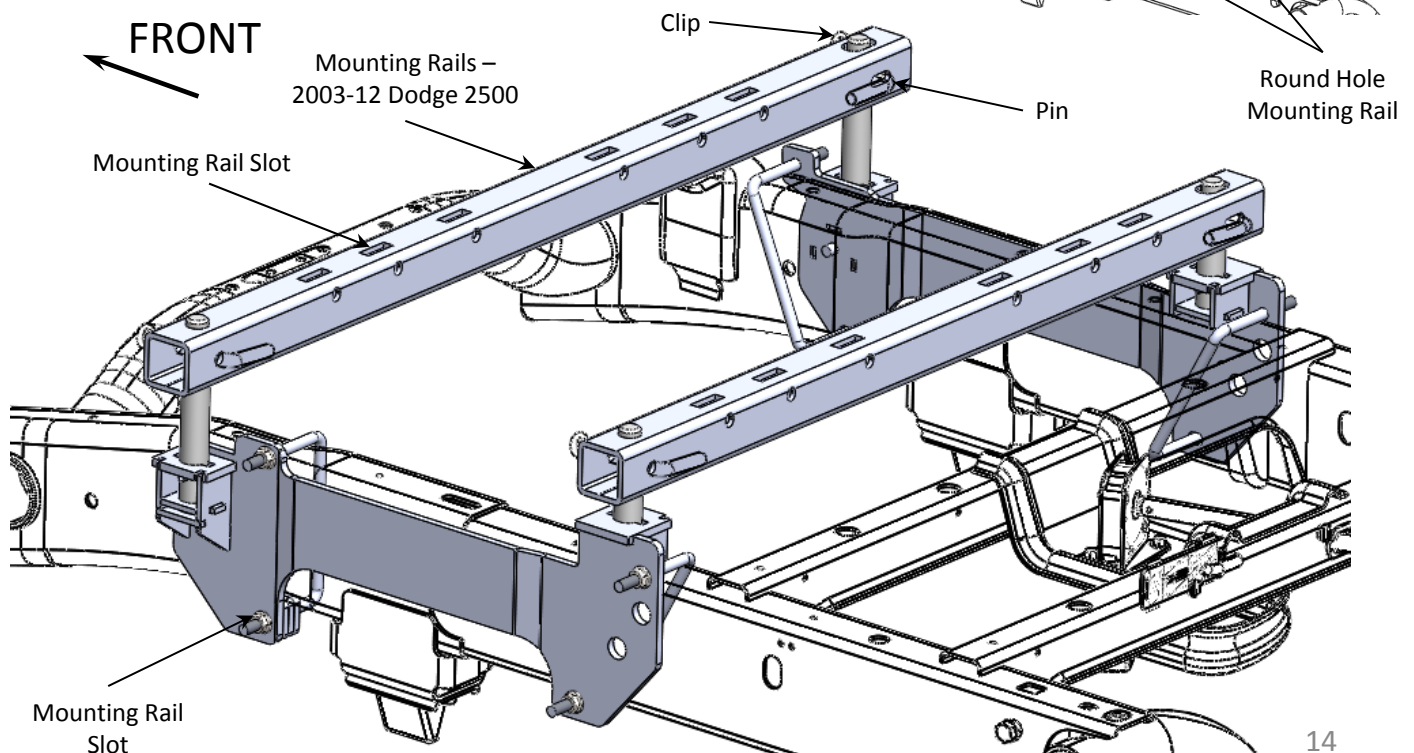
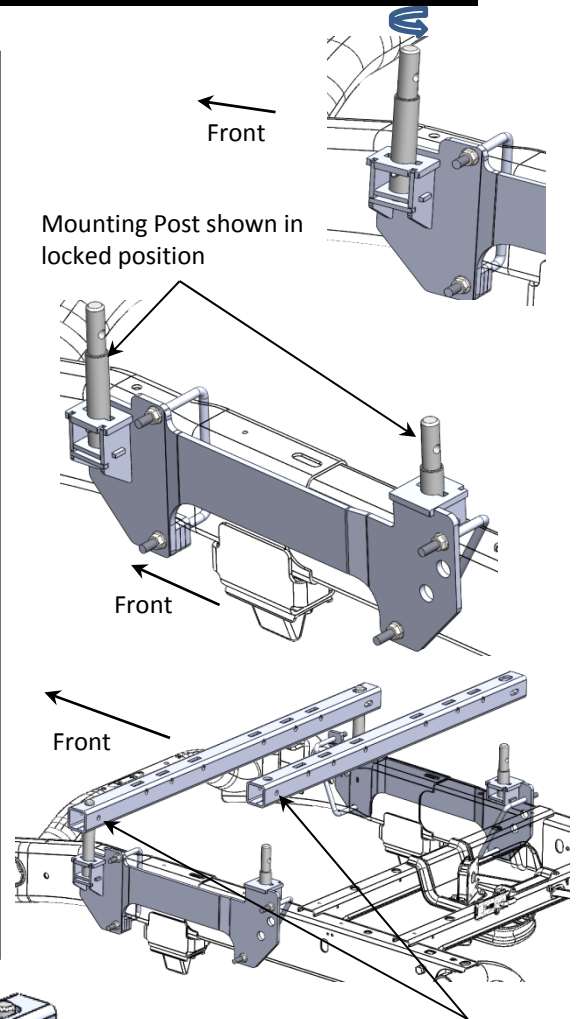

**Assembled View with Bed Removed**

