

TOOLS REQUIRED

- Plastic panel pry tool
- Torx T15 drive
- 10mm socket
- 15mm socket
- 18mm socket
- 3/4" socket
- 7/16" socket
- 1/2" socket
- 3/4" open end wrench
- 5/32" Allen wrench
- Zip-ties

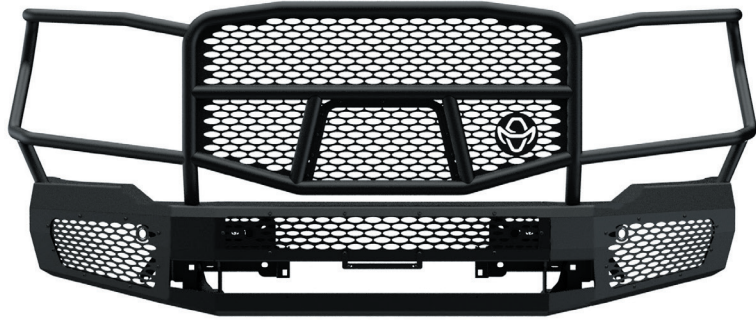

Please read through the entire set of instructions before continuing with installation to familiarize yourself with the process, save time, and make sure that you have all the correct tools and parts needed to complete this installation. More detailed instructions can be found on our website.

DISASSEMBLY INSTRUCTIONS

1. To remove the factory bumper, you will need to remove the factory grille. You will need to remove the side panels first. Start by removing the inner fender well screws. This will allow you to get to the back side of the plastic clips. There will also be a small screw in the corner that needs to be removed before the side panel can be pulled off.

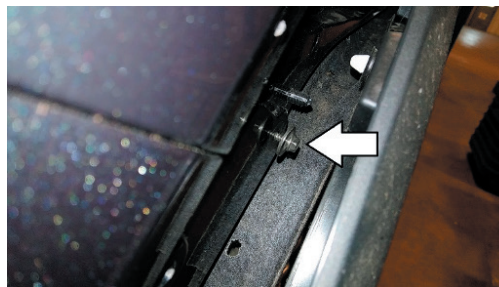
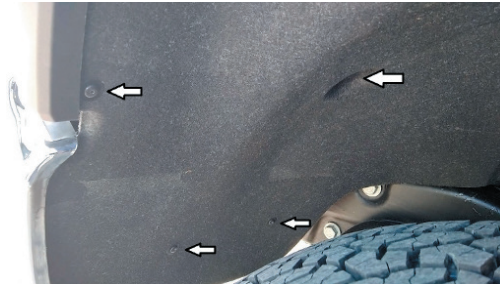

2. Remove the factory grille. Open the hood and remove the hood release latch by removing two T15 screws. Remove the ten plastic clips holding the plastic shield located above the grille.



3. Disconnect the sensor/fog light wiring harness. Also, if vehicle is installed with a front camera, unhook the connector. The grille can then be removed by remove (4) 10mm bolts on top and pulling the grille away from the truck to release the clips.

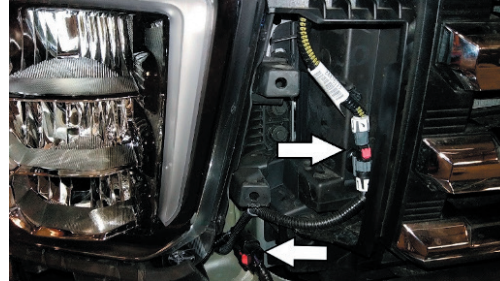

4. Remove the factory bumper side brackets. There will be (3) 15mm bolts on each side.

5. On vehicles with diesel motors, unplug the block heater plug.



6. Remove the factory bumper by removing the (2) 18mm bolts from each side of the frame. They will be facing down.



7. Lay the bumper down then remove the sensor and fog light wiring harness and block heater plug (if present) from the bumper. You will have to remove the (2) large black bumper support plates to remove sensors.

8. Reinstall the factory grille, plastic radiator cover and side panels.

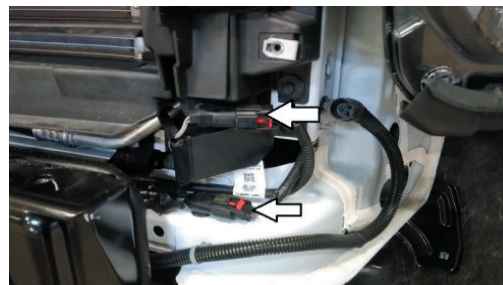

9. Unplug and remove the lower louvered air duct panel.

10. Pop out the clips and insert them in the provided brackets.

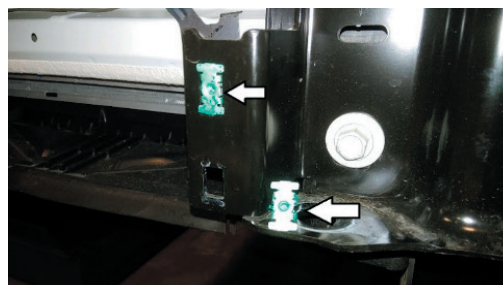

11. Remove the two black bumper mounting plate by removing the (4) 15mm bolts. The bolts will be used to install the Ranch Hand Frontend.

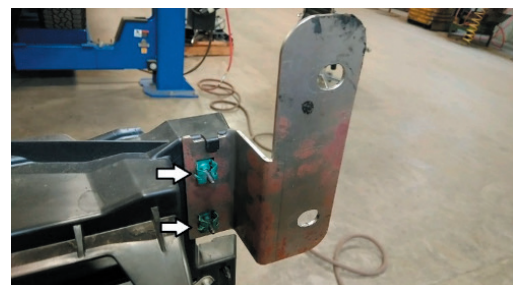

PREPPING THE MIDNIGHT FRONT BUMPER FOR INSTALLATION:

1. Begin by taking the bumper out of the box and position the bumper on the ground, just as it would sit on your truck/SUV.
2. Locate the passenger and driver side fog light inserts and fog light brackets. *Note: These must be installed at the same time as they share two of the provided bolts, washers, and bolt locations.
3. Place the fog light insert through the back of the bumper. Using a 5/32" Allen wrench, Allen key, or hex key and 7/16" wrench secure the two bottom and two outer edge holes with the provided ¼" socket button head bolts and Keps nut.
4. Place the fog light bracket in position over the fog light insert. Secure both the fog light inserts and bracket to the bumper using the ¼" socket button head bolts and Keps nuts (8x per side).
5. If equipped, install the OEM fog lights into the bumper using the included brackets as shown in the installation diagram. Two sets of brackets are included to accommodate for LED fogs and Halogen fogs.
6. Repeat this step for both the passenger and driver side of the bumper.
7. Place the center fog light insert, from the inside, in the middle of the bumper and begin securing the ¼" socket button head bolts and Keps nuts. Secure eight of the holes, leaving the center bottom two holes as is without bolts. These will be used to attach the license plate later.
8. Place the removable camera insert on the grille guard from the inside and attach with the ¼" socket button head bolts and Keps nuts. *Note: If your vehicle comes equipped with a front mounted camera please skip this step.

FOR VEHICLES WITH SENSORS:

1. If your vehicle has OEM front parking sensors, carefully remove the sensors from the OEM bumper.
2. Knockout sensor holes on each side of the bumper and on each insert.
3. Using the grommets provided in the included bolt pack, reinstall the OEM sensors. Place the grommet inside the hole directly on the insert. Once it is in place, apply WD-40 around the inside of the grommet to help guide the sensor into place without damaging it. Push the sensor through the grommet from the back side of the insert.
4. Take the sensor pigtail/wires that were removed from the OEM bumper and route the wiring harness from sensor to sensor on the bumper. Route the wires through the mounting bracket using the holes located on the sides of both brackets. Be sure to avoid leaving the wiring harness on top of the bracket.

5. Any and all aftermarket products that you plan to attach to the bumper, including lightbars, should be installed at this time for ease of installation.

INSTALLING THE MIDNIGHT FRONT BUMPER:

1. Install the Ranch Hand mounting brackets to the frame of the truck as shown on the included mounting diagram. For trucks with tow hooks, remove each tow hook, flip it, and reinstall. This will allow the factory tow hooks to be used with the midnight bumper.
2. With one person supporting each side, line the bumper's mounting plate up with the mounting bracket. A third person should be underneath the vehicle to temporarily tighten each of the bolts to secure the bumper to the mounting bracket per mounting diagram.
3. With two people still supporting each side of the bumper, adjust the bumper so that there is an even amount of space along the grille, the headlights, and all the way across the front of the truck. Once the bumper is in place, continue by tightening all the mounting hardware.
4. Reconnect any OEM wiring harnesses disconnected when removing the OEM bumper. This includes fog light wiring harnesses or sensor wiring harnesses. All must be plugged back into OEM location on truck. It may be necessary to use zip ties to secure loose wiring.

ADA INSTALLATION:

1. See packing list to identify ADA for installation.
2. Have one person hold the ADA bar in place while the other places bolts through the bolt holes and hand tighten the nuts (very similar to step 1 above titled, "Installing the Midnight Front Bumper). DO NOT over-tighten the bolts, otherwise step 2 will become difficult.
3. Adjust the placement of the ADA until it is flush and aligned with the rest of the bumper. Once in place, firmly tighten the bolts.

LICENSE PLATE BRACKET INSTALLATION

1. Retrieve the U-shaped license plate bracket as well as the four ¼" socket button head bolts and Keps nuts.
2. Attach the top of the U-bracket to the grille guard using the two ¼" socket button head bolts and Keps nuts.
3. Attach the license plate to the bottom of the U-bracket using the two ¼" socket button head bolts and Keps nuts bolts.
4. Check and tighten all mounting fasteners.

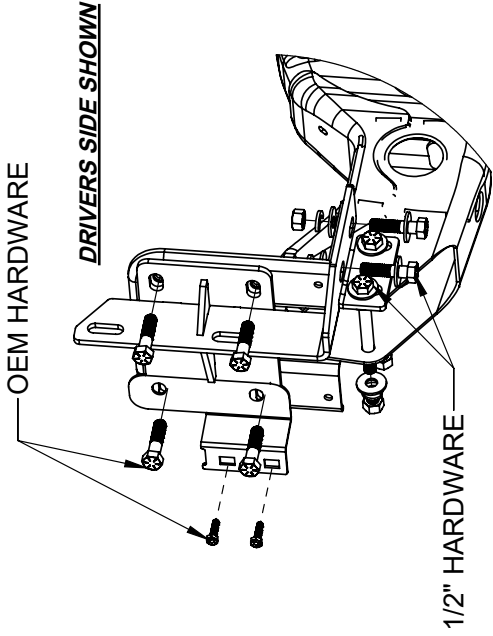

MOUNTING BRACKET INSTALLATION

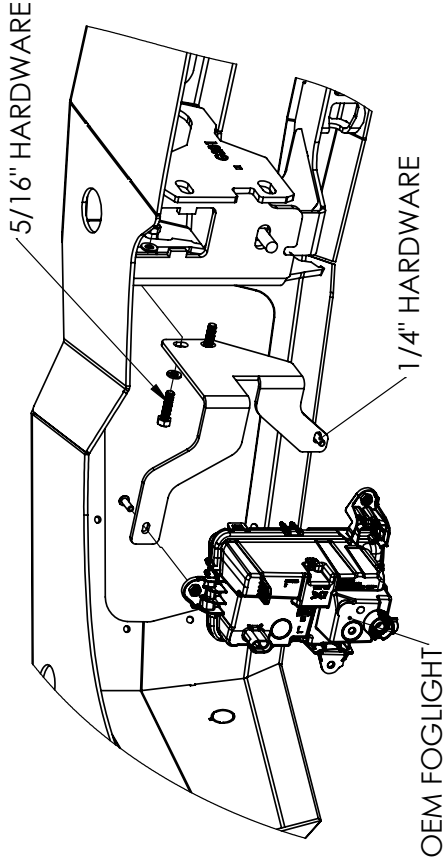

OEM FOG INSTALLATION

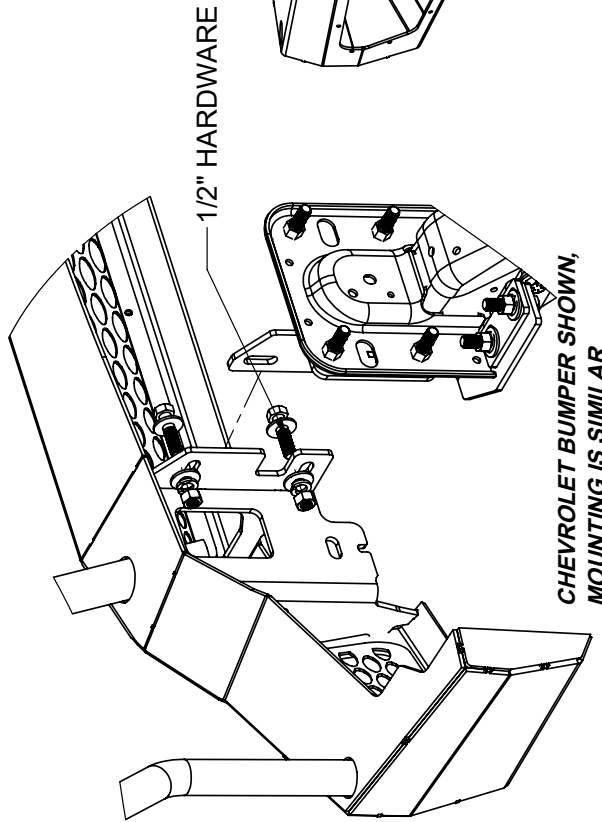

BUMPER INSTALLATION

