

# BRACKET KIT INSTALLATION

SKU# RB-0102-BK



COMPONENTS		HARDWARE	
<p><b>DRIVER SIDE</b></p> <p>Qty: 1 Front Bracket</p> <p>Qty: 2 Center Bracket</p> <p>Qty: 1 Rear Bracket</p>	<p><b>PASSENGER SIDE</b></p> <p>Qty: 1 Front Bracket</p> <p>Qty: 2 Center Bracket</p> <p>Qty: 1 Rear Bracket</p>	<p>Qty: 18 M8 x 30MM Hex Head Bolts</p> <p>Qty: 34 M8 Flat Washers</p> <p>Qty: 4 M8 Square Head Bolts</p>	<p>Qty: 34 M8 Lock Washers</p> <p>Qty: 18 M8 Hex Head Nuts</p>
TOOLS REQUIRED		INSTALLATION NOTES	
<p>RATCHET</p> <p>TORQUE WRENCH</p> <p>13MM SOCKET</p> <p>RETAINER REMOVAL TOOL</p>	<p>NOTE: Center Brackets are NOT used on Regular Cab Models</p> <p>TORQUE NOTE: Bolts and nuts should be torqued to 15-20 ft lbs.</p> <p>NOTE: Hardware for Board Installation is included.</p> <p>NOTE: Some spare hardware is included.</p>		

Remove all contents from the package and check brackets for any damage. Also, verify that all components and hardware listed above are included before you begin installation.

Read through entire installation manual and installation drawings to ensure that you understand all of the components and hardware before proceeding with installation.

**NOTE: When installing the brackets, all hardware must be left loose until all of the items are attached.**

Locate factory hole locations in four (4) places per side on the body mount.

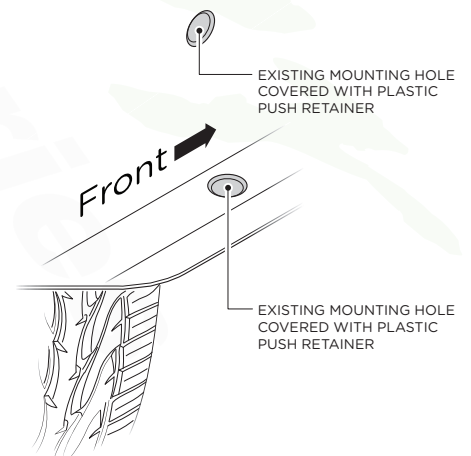
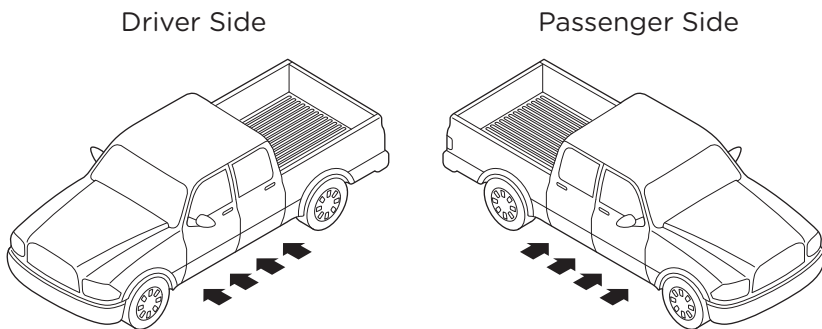

# BRACKET ORIENTATION

## DRIVER SIDE

NOTE: Center Brackets are NOT used on Regular Cab Models

*Raptor*  
Series

1. Begin installation on driver side. Position the Front Bracket, Center Brackets and Rear Bracket as shown in diagram.

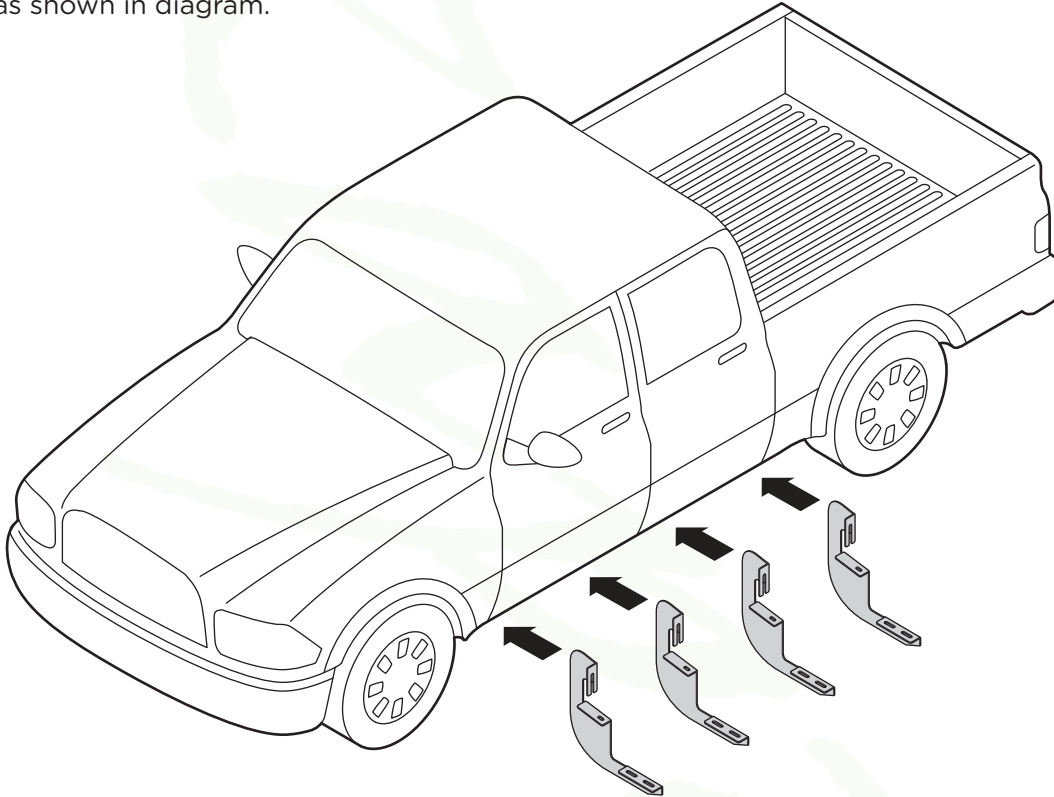

2. Driver Side Front Bracket cradle (2a), Driver Side Center Bracket cradles (2b, 2c), and Driver Side Rear Bracket cradle (2d) will all face towards the front of the truck.

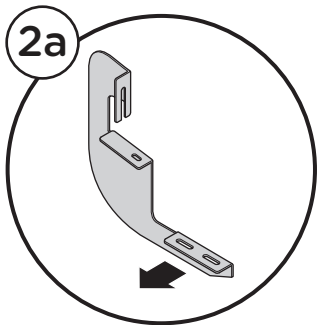

Driver Side  
Front Bracket

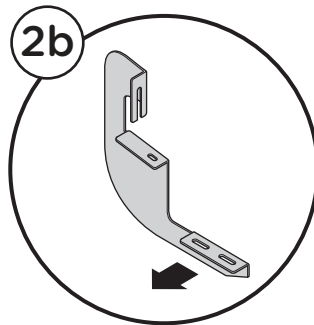

Driver Side  
Center Bracket

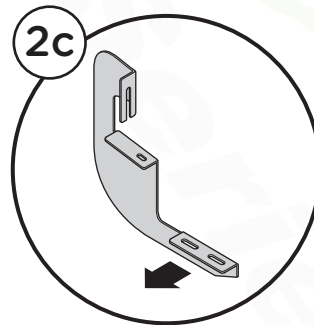

Driver Side  
Center Bracket

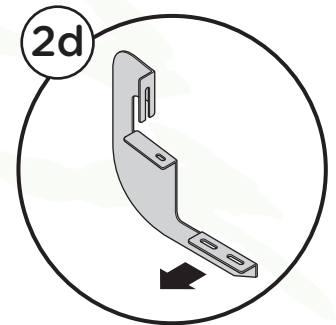

Driver Side  
Rear Bracket

# PLASTIC PUSH RETAINER REMOVAL

## DRIVER SIDE

*Raptor*  
Series

NOTE: Removal of Plastic Push Retainer is needed to expose factory holes.

**3.** Follow the steps shown below to remove the upper and lower Plastic Push Retainers.

Use Retainer Removal Tool to grab underneath the upper Plastic Push Retainer in the rocker panel.

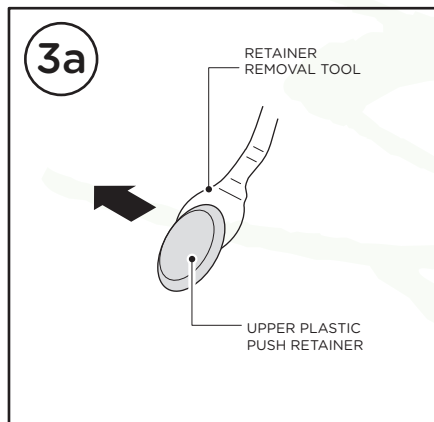

Pull the upper Plastic Push Retainer out of the rocker panel to expose threaded holes that will be used for bracket installation.

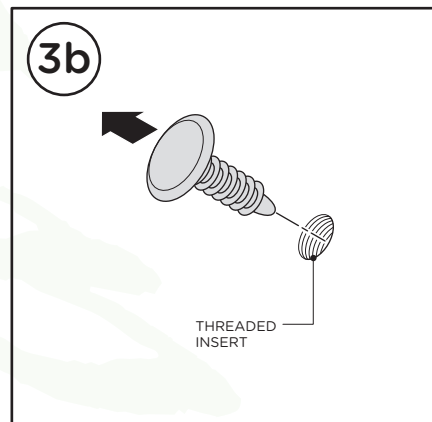

Use Retainer Removal Tool to grab underneath the lower Plastic Push Retainer in the rocker panel.

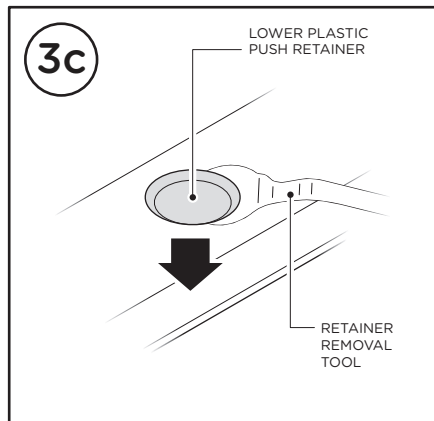

Pull the lower Plastic Push Retainer out of the rocker panel to expose threaded holes that will be used for bracket installation.

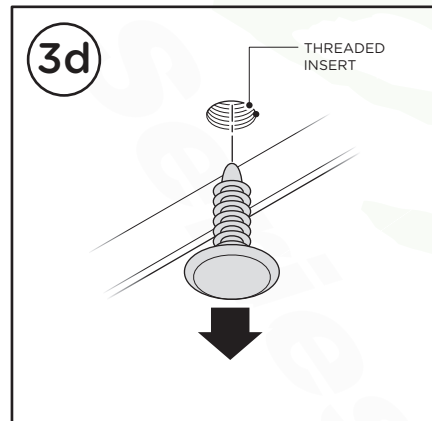

# BRACKET INSTALLATION

## DRIVER SIDE

*Raptor*  
Series

4. Fasten the top portion of the Driver Side Front Bracket by using (1) M8 x 30 MM Hex Head Bolt, (1) M8 Flat Washer and (1) M8 Lock Washer.

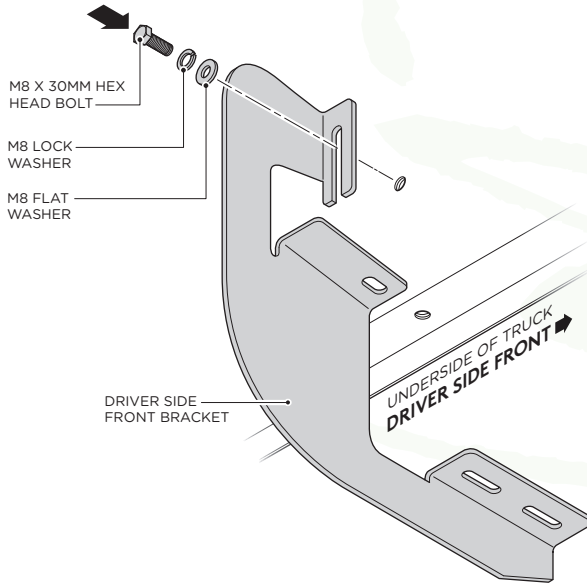

5. Fasten the bottom portion of the Driver Side Front Bracket by using (1) M8 x 30MM Hex Head Bolt, (1) M8 Flat Washer and (1) M8 Lock Washer.

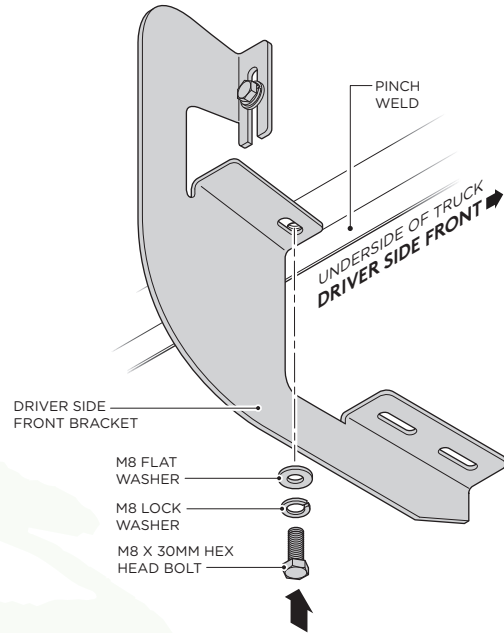

6. Fasten the top portion of the first Driver Side Center Bracket by using (1) M8 x 30MM Hex Head Bolt, (1) M8 Flat Washer and (1) M8 Lock Washer.

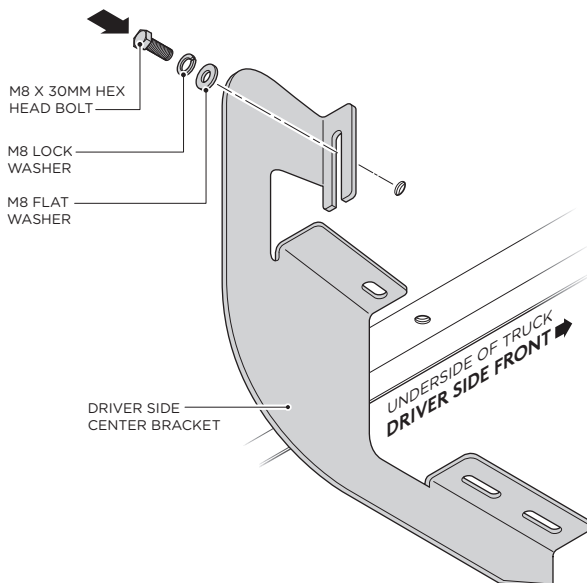

\*NOT Used on Regular Cab Models

7. Fasten the bottom portion of the first Driver Side Center Bracket by using (1) M8 x 30MM Hex Head Bolt, (1) M8 Flat Washer and (1) M8 Lock Washer.

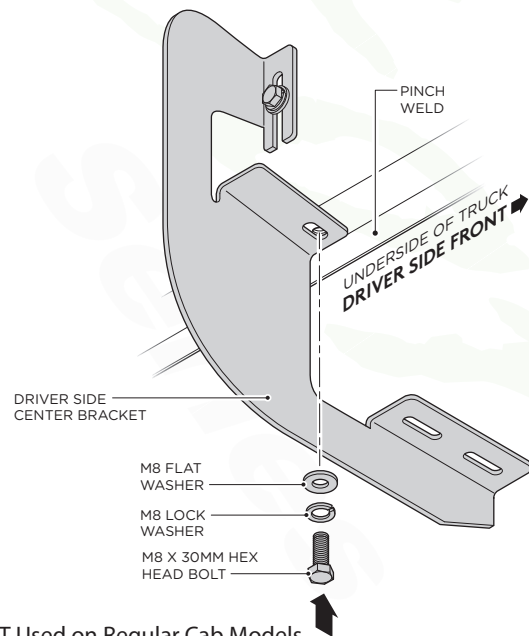

\*NOT Used on Regular Cab Models

# BRACKET INSTALLATION

## DRIVER SIDE



- 8.** Fasten the top portion of the second Driver Side Center Bracket by using (1) M8 x 30MM Hex Head Bolt, (1) M8 Flat Washer and (1) M8 Lock Washer.

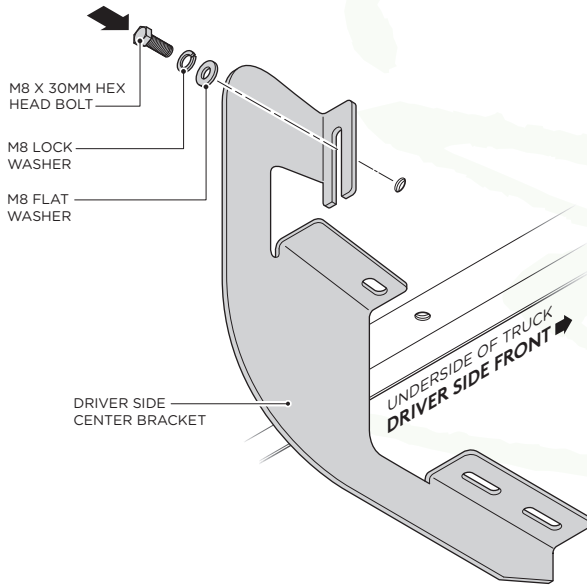

\*NOT Used on Regular Cab Models

- 9.** Fasten the bottom portion of the second Driver Side Center Bracket by using (1) M8 x 30MM Hex Head Bolt, (1) M8 Flat Washer and (1) M8 Lock Washer.

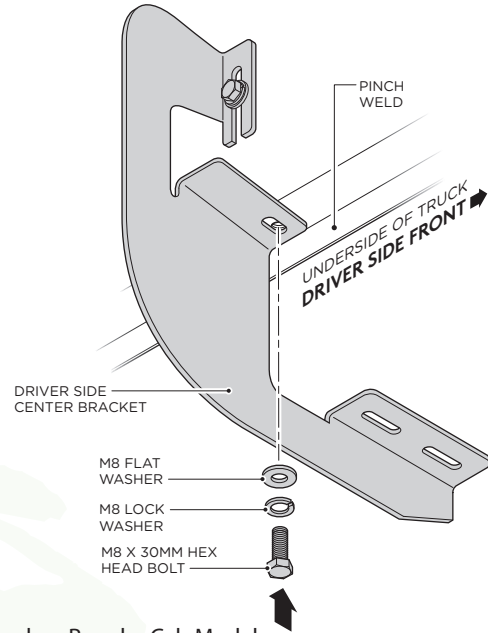

\*NOT Used on Regular Cab Models

- 10.** Fasten the top portion of the Driver Side Rear Bracket by using (1) M8 x 30MM Hex Head Bolt, (1) M8 Flat Washer and (1) M8 Lock Washer.

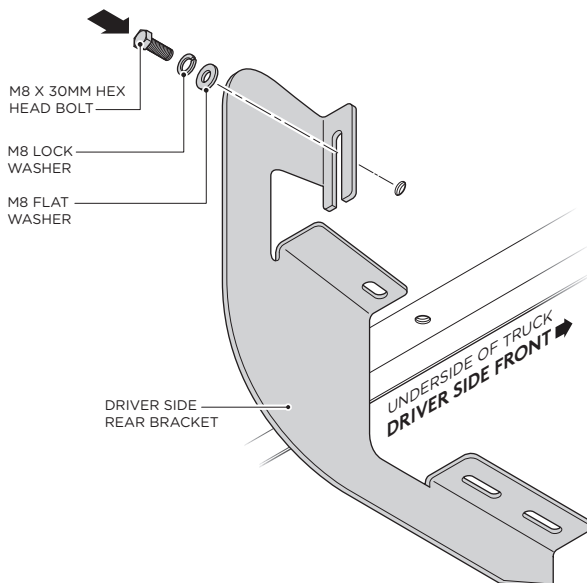

- 11.** Fasten the bottom portion of the Driver Side Rear Bracket by using (1) M8 x 30MM Hex Head Bolt, (1) M8 Flat Washer and (1) M8 Lock Washer.

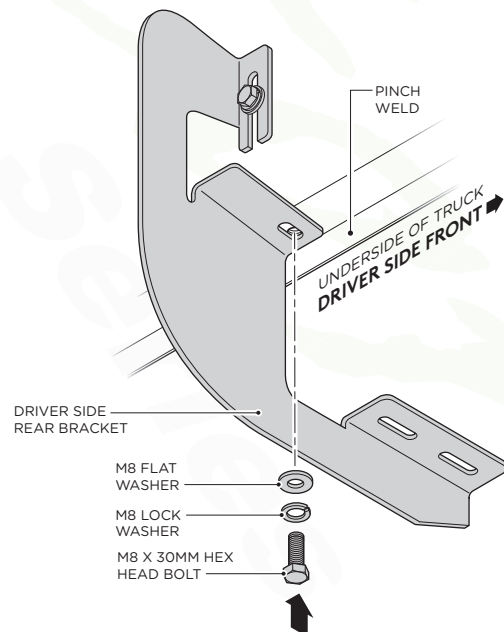

# RUNNING BOARD INSTALLATION

DRIVER SIDE

*Raptor*  
Series

- 12.** Fasten the Running Board to the Driver Side Front Bracket cradle by using (2) M8 Flat Washers, (2) M8 Lock Washers and (2) M8 Hex Head Nuts.

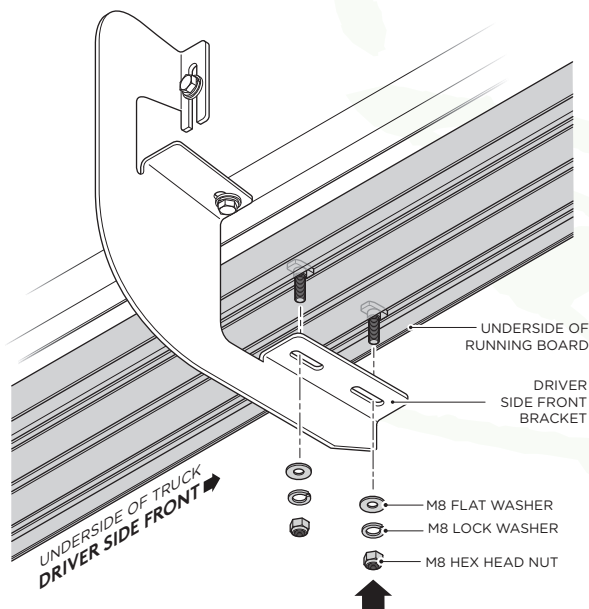

- 13.** Fasten the Running Board to the first Driver Side Center Bracket cradle by using (2) M8 Flat Washers, (2) M8 Lock Washers and (2) M8 Hex Head Nuts. Excluding Regular Cabs.

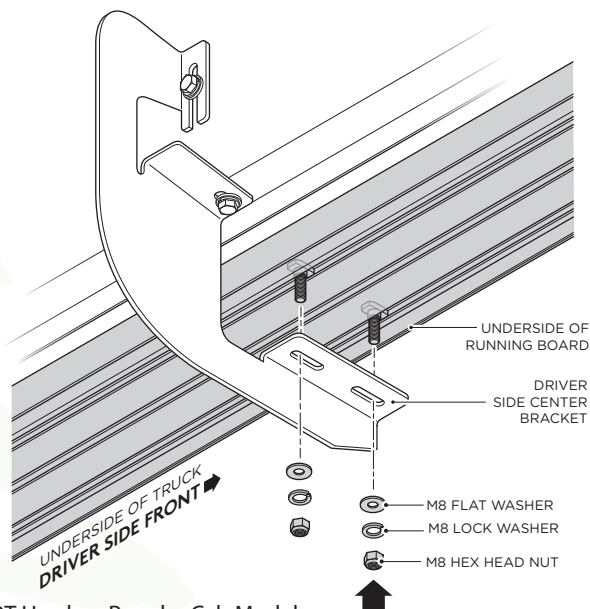

\*NOT Used on Regular Cab Models

- 14.** To fasten the Running Board to the second Driver Side Center Bracket cradle, insert (2) M8 Square Head Bolts (14a), then fasten using (2) M8 Flat Washers, (2) M8 Lock Washers and (2) M8 Hex Head Nuts.

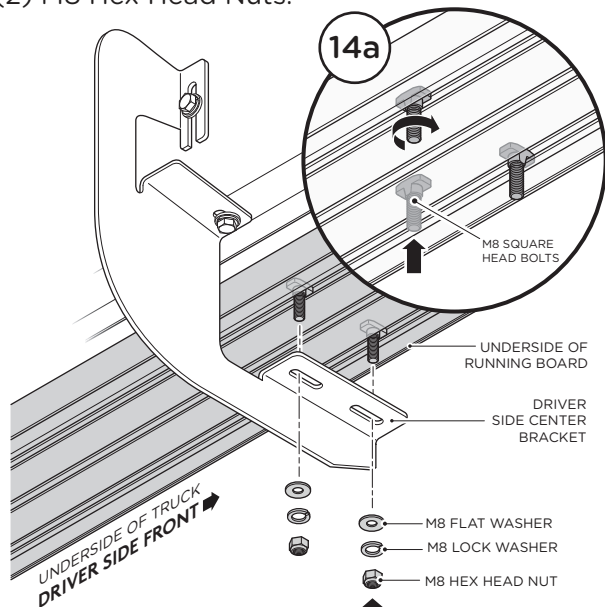

\*NOT Used on Regular Cab Models

- 15.** Fasten the Running Board to the Driver Side Rear Bracket cradle by using (2) M8 Flat Washers, (2) M8 Lock Washers and (2) M8 Hex Head Nuts.

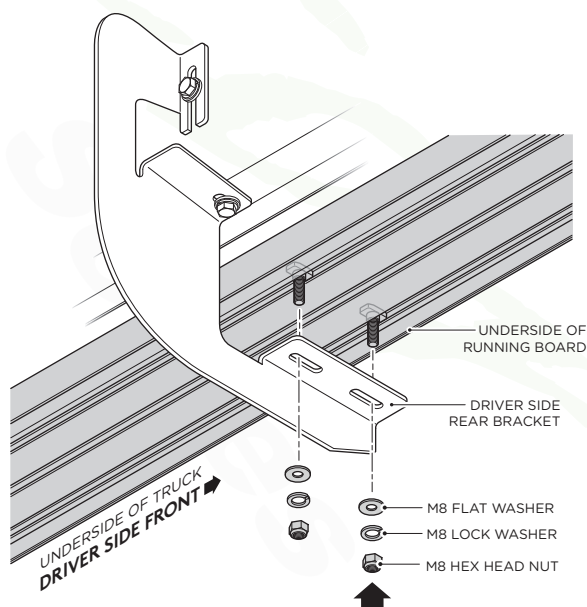

# BRACKET ORIENTATION

## PASSENGER SIDE

NOTE: Center Brackets are NOT used on Regular Cab Models



1. Begin installation on passenger side. Position the Front Bracket, Center Brackets and Rear Bracket as shown in diagram.

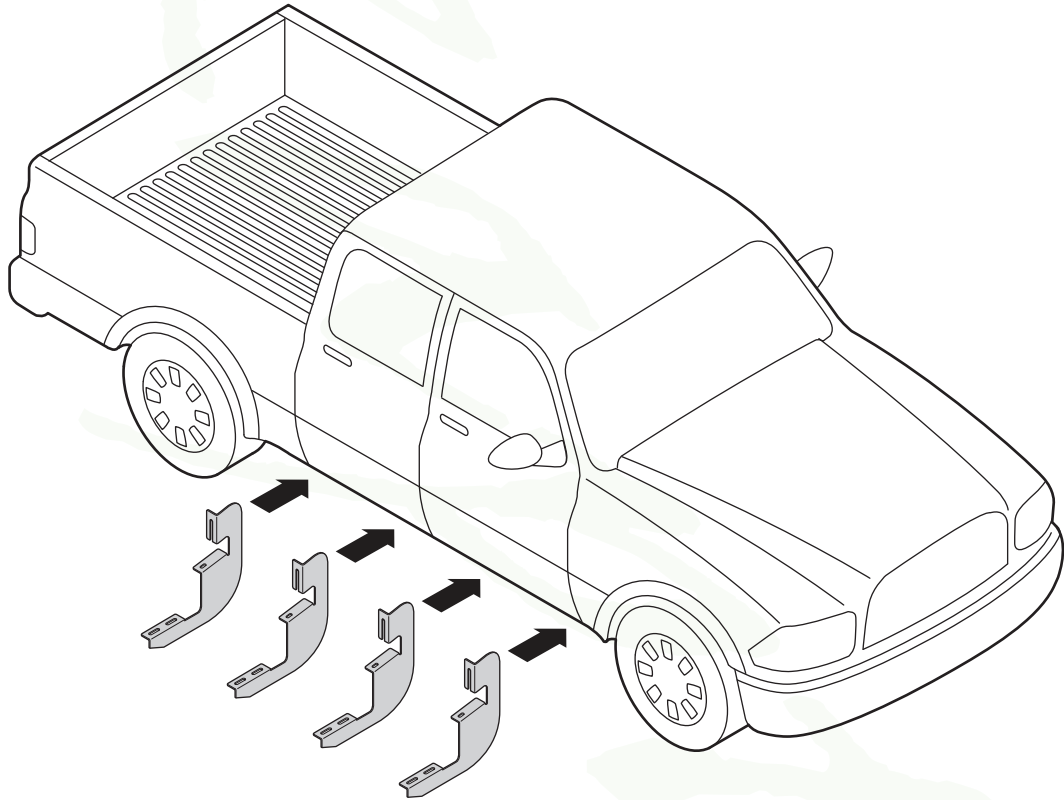

2. Passenger Side Front Bracket cradle (2a), Passenger Side Center Bracket cradles (2b, 2c), and Passenger Side Rear Bracket cradle (2d) will all face towards the front of the truck.

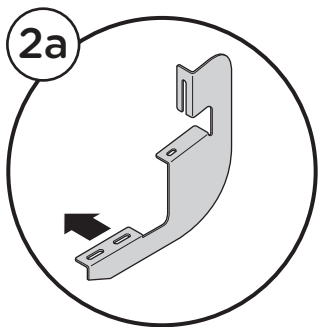

Passenger Side Front Bracket

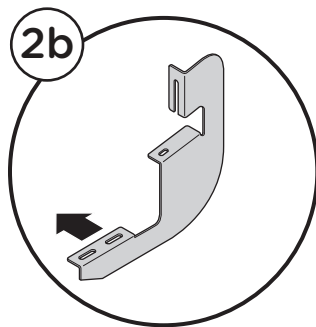

Passenger Side Center Bracket

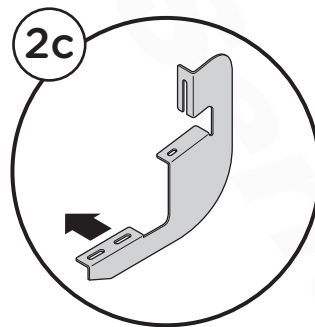

Passenger Side Center Bracket

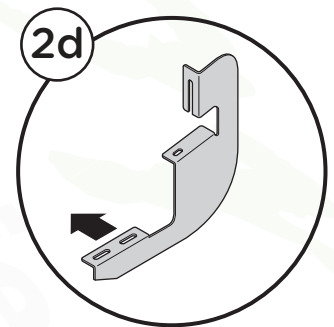

Passenger Side Rear Bracket

# PLASTIC PUSH RETAINER REMOVAL

## PASSENGER SIDE

*Raptor*  
Series

NOTE: Removal of Plastic Push Retainer is needed to expose factory holes.

**3.** Follow the steps shown below to remove the Plastic Push Retainers.

Use Retainer Removal Tool to grab underneath the upper Plastic Push Retainer in the rocker panel.

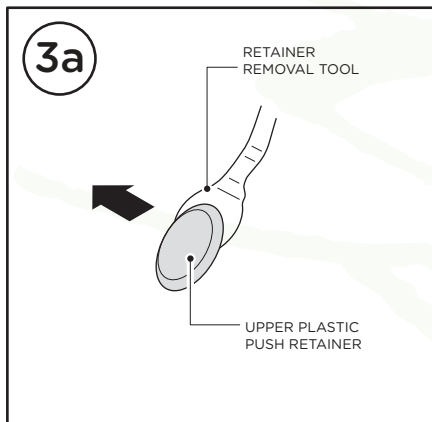

Pull the upper Plastic Push Retainer out of the rocker panel to expose threaded holes that will be used for bracket installation.

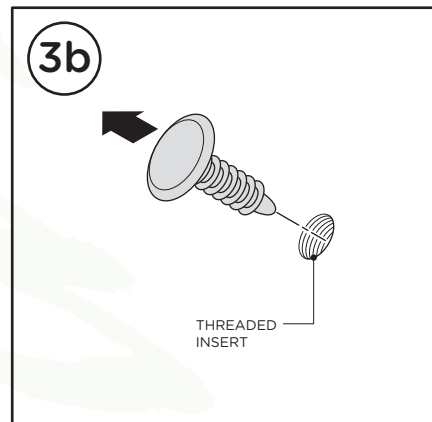

Use Retainer Removal Tool to grab underneath the lower Plastic Push Retainer in the rocker panel.

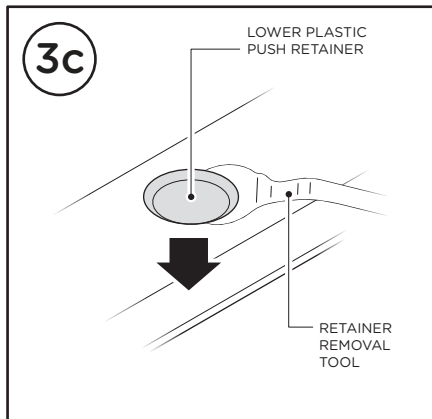

Pull the lower Plastic Push Retainer out of the rocker panel to expose threaded holes that will be used for bracket installation.

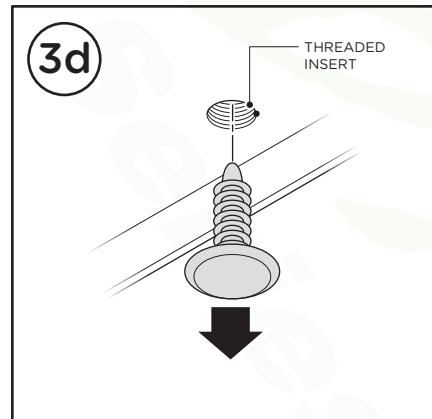

# BRACKET INSTALLATION

## PASSENGER SIDE

*Raptor*  
Series

- 4.** Fasten the top portion of the Passenger Side Front Bracket by using (1) M8 x 30MM Hex Head Bolt, (1) M8 Flat Washer and (1) M8 Lock Washer.

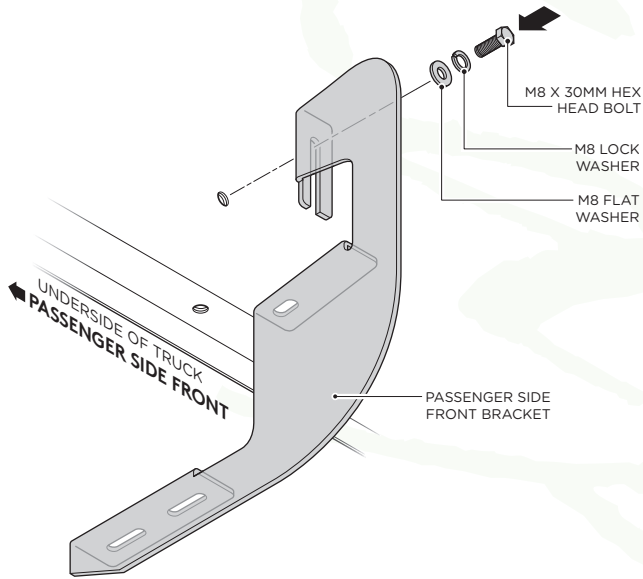

- 5.** Fasten the bottom portion of the Passenger Side Front Bracket by using (1) M8 x 30MM Hex Head Bolt, (1) M8 Flat Washer and (1) M8 Lock Washer.

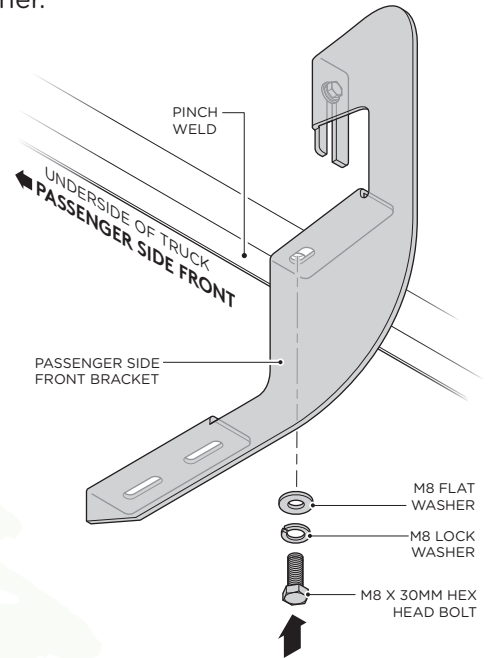

- 6.** Fasten the top portion of the first Passenger Side Center Bracket by using (1) M8 x 30MM Hex Head Bolt, (1) M8 Flat Washer and (1) M8 Lock Washer.

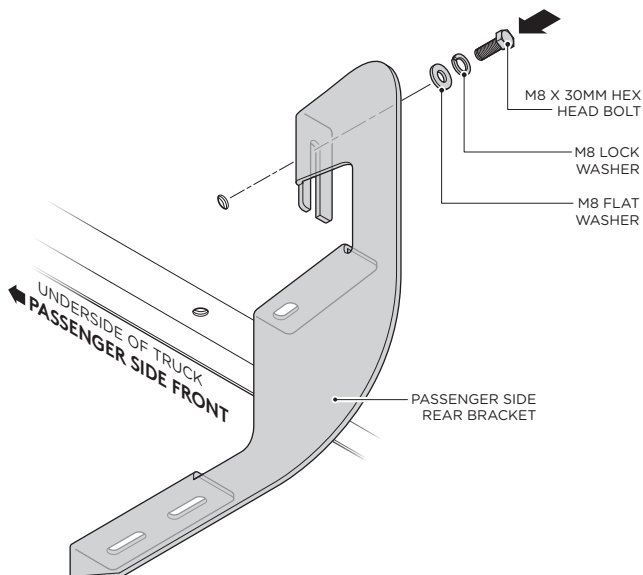

- 7.** Fasten the bottom portion of the first Passenger Side Center Bracket by using (1) M8 x 30MM Hex Head Bolt, (1) M8 Flat Washer and (1) M8 Lock Washer.

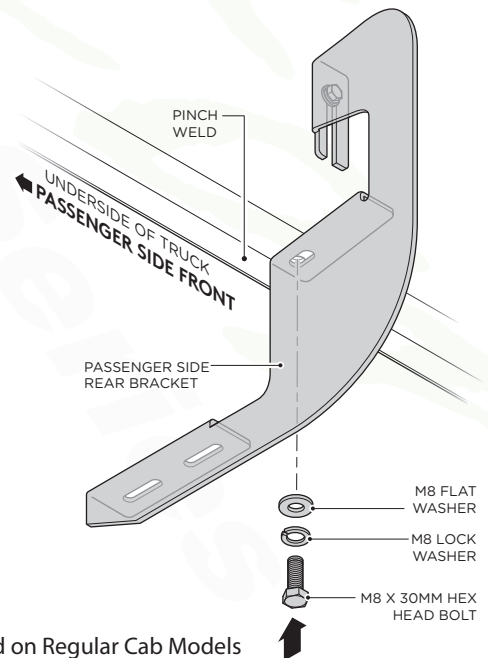

\*NOT Used on Regular Cab Models

\*NOT Used on Regular Cab Models

# BRACKET INSTALLATION

## PASSENGER SIDE



- 8.** Fasten the top portion of the second Passenger Side Center Bracket by using (1) M8 x 30MM Hex Head Bolt, (1) M8 Flat Washer and (1) M8 Lock Washer.

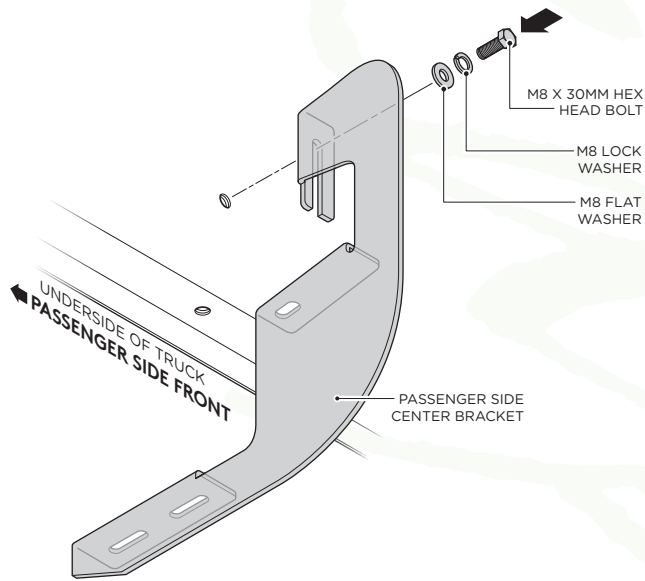

\*NOT Used on Regular Cab Models

- 9.** Fasten the bottom portion of the second Passenger Side Center Bracket by using (1) M8 x 30MM Hex Head Bolt, (1) M8 Flat Washer and (1) M8 Lock Washer.

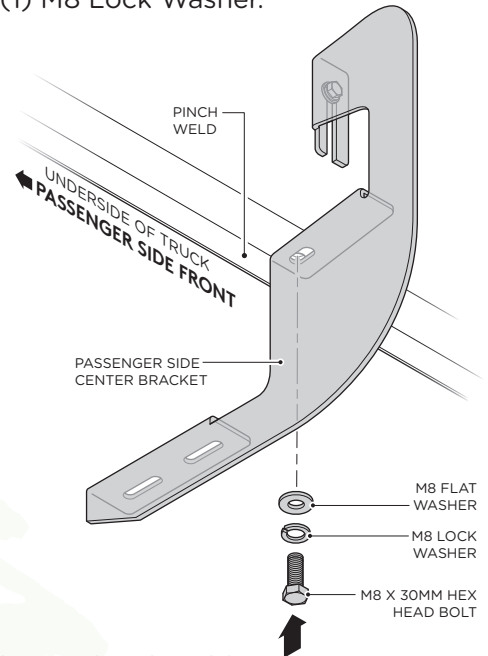

\*NOT Used on Regular Cab Models

- 10.** Fasten the top portion of the Passenger Side Rear Bracket by using (1) M8 x 30MM Hex Head Bolt, (1) M8 Flat Washer and (1) M8 Lock Washer.

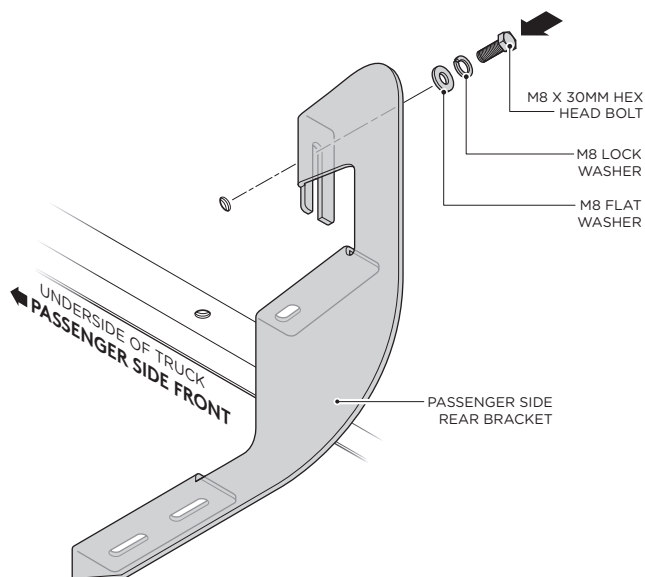

- 11.** Fasten the bottom portion of the Passenger Side Rear Bracket by using (1) M8 x 30MM Hex Head Bolt, (1) M8 Flat Washer and (1) M8 Lock Washer.

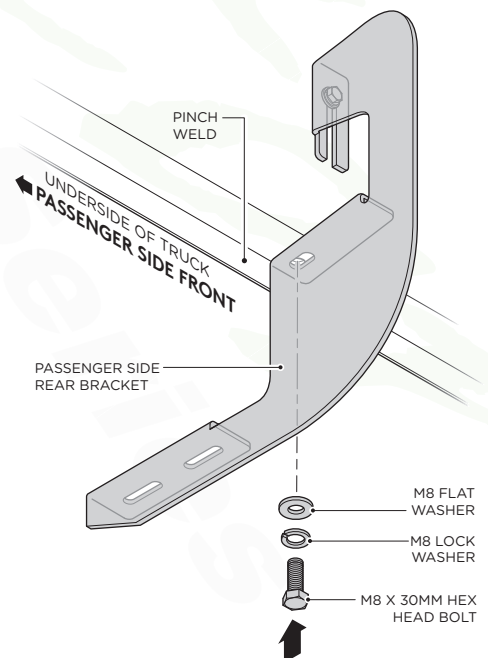

# RUNNING BOARD INSTALLATION

## PASSENGER SIDE



**12.** Fasten the Running Board to the Passenger Side Front Bracket cradle by using (2) M8 Flat Washers, (2) M8 Lock Washers and (2) M8 Hex Head Nuts.

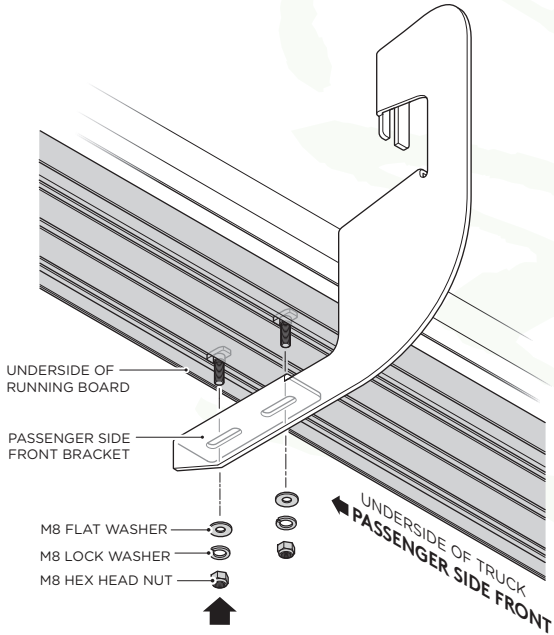

**13.** Fasten the Running Board to the first Passenger Side Center Bracket cradle by using (2) M8 Flat Washers, (2) M8 Lock Washers and (2) M8 Hex Head Nuts.

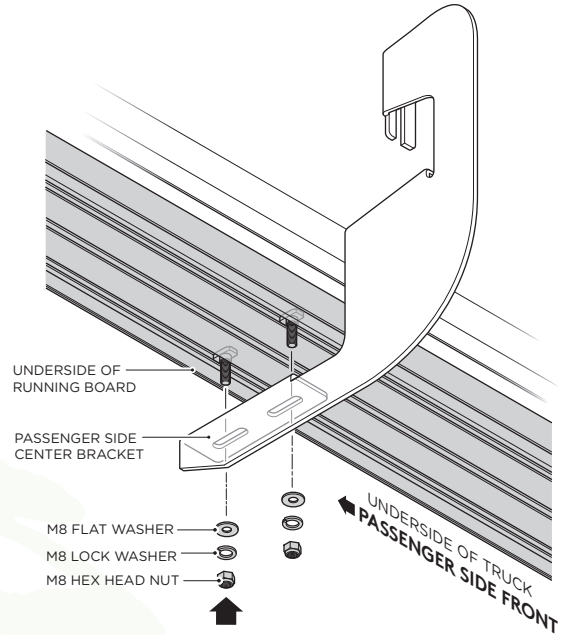

\*NOT Used on Regular Cab Models

**14.** To fasten the Running Board to the second Passenger Side Center Bracket cradle, insert (2) M8 Square Head Bolts (14a), then fasten using (2) M8 Flat Washers, (2) M8 Lock Washers and (2) M8 Hex Head Nuts.

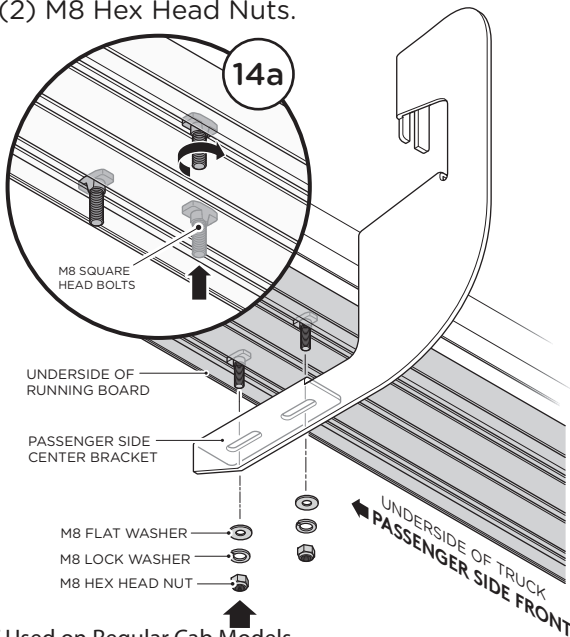

\*NOT Used on Regular Cab Models

**15.** Fasten the Running Board to the Passenger Side Rear Bracket cradle by using (2) M8 Flat Washers, (2) M8 Lock Washers and (2) M8 Hex Head Nuts.

