

BRACKET KIT INSTALLATION

SKU# RB-0101-BK



COMPONENTS		HARDWARE	
<p>DRIVER SIDE</p> <p>Qty: 1 Front Bracket</p> <p>Qty: 1 Center Bracket</p> <p>Qty: 1 Rear Bracket</p>	<p>PASSENGER SIDE</p> <p>Qty: 1 Front Bracket</p> <p>Qty: 1 Center Bracket</p> <p>Qty: 1 Rear Bracket</p>	<p>Qty: 12 M8 x 30MM Hex Head Bolts</p> <p>Qty: 24 M8 Flat Washers</p> <p>Qty: 12 M8 U Nut Clips</p>	<p>Qty: 24 M8 Lock Washers</p> <p>Qty: 12 M8 Hex Head Nuts</p>
TOOLS REQUIRED		INSTALLATION NOTES	
<p>RATCHET</p> <p>TORQUE WRENCH</p> <p>RETAINER REMOVAL TOOL</p>	<p>13MM SOCKET</p> <p>14MM SOCKET</p>	<p>TORQUE NOTE: Bolts and nuts should be torqued to 15-20 ft lbs.</p> <p>NOTE: Hardware for Board Installation is included.</p> <p>NOTE: Some spare hardware is included.</p>	

Remove all contents from the package and check brackets for any damage. Also, verify that all components and hardware listed above are included before you begin installation.

Read through entire installation manual and installation drawings to ensure that you understand all of the components and hardware before proceeding with installation.

NOTE: When installing the brackets, all hardware must be left loose until all of the items are attached.

Locate factory hole locations in four (4) places per side on the body mount.

Driver Side

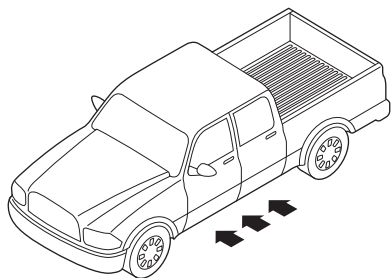

Passenger Side

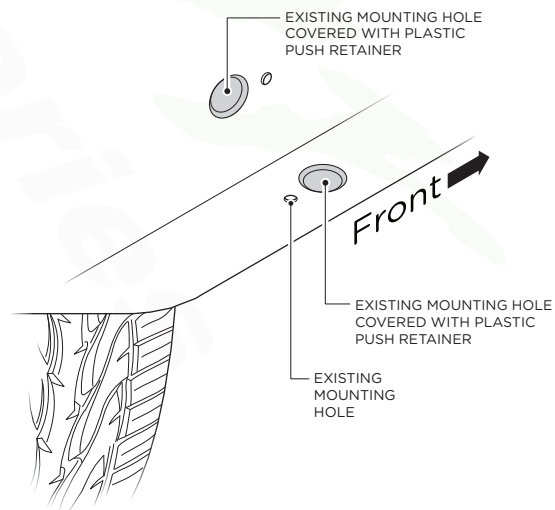
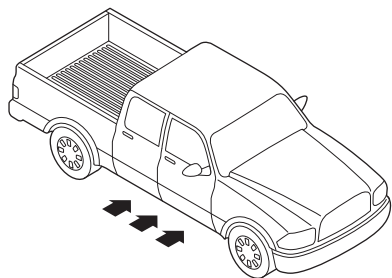

BRACKET ORIENTATION

DRIVER SIDE

Raptor
Series

1. Begin installation on driver side. Position the Front Bracket, Center Bracket and Rear Bracket as shown in diagram.

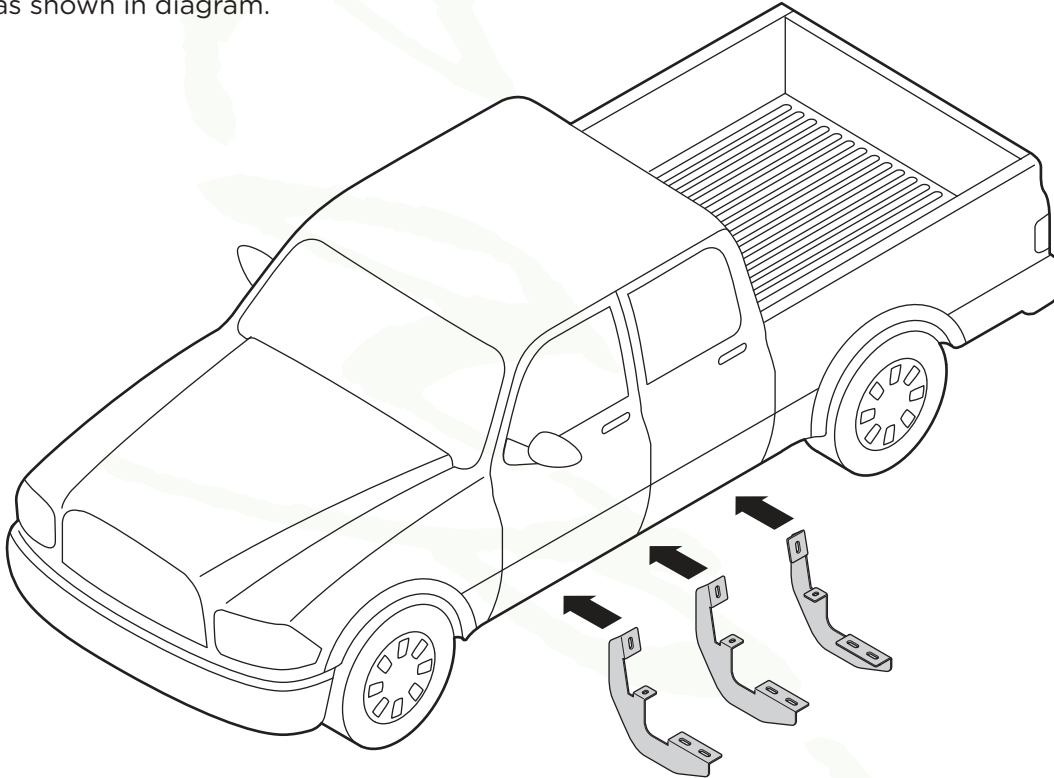

2. Driver Side Front Bracket cradle (2a) and Driver Side Center Bracket cradle (2b), will face towards the rear and Driver Side Rear Bracket cradle (2d) will face towards the front of the truck.

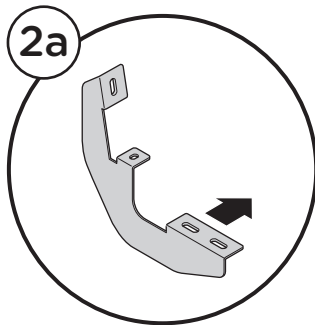

Driver Side
Front Bracket

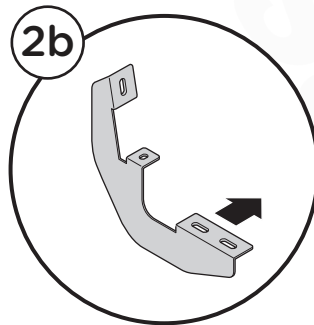

Driver Side
Center Bracket

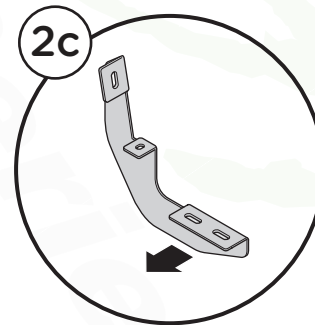

Driver Side
Rear Bracket

PLASTIC PUSH RETAINER REMOVAL

DRIVER SIDE

Raptor
Series

NOTE: Removal of Plastic Push Retainer is needed to expose factory holes.

- 3.** Follow the steps shown below to show removal of the upper and lower Plastic Push Retainers and installation of M8 U-Nuts.

Use Retainer Removal Tool to grab underneath the upper Plastic Push Retainer in the rocker panel.

Pull the upper Plastic Push Retainer out of the rocker panel to expose threaded holes that will be used for bracket installation.

Use Retainer Removal Tool to grab underneath the lower Plastic Push Retainer in the rocker panel.

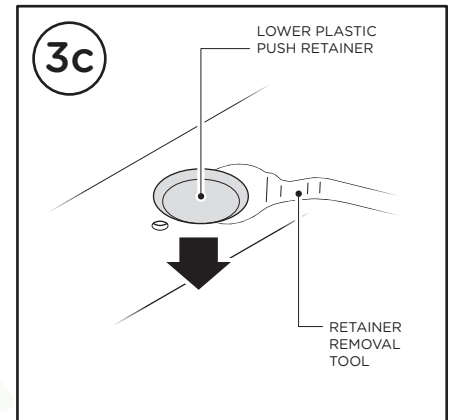
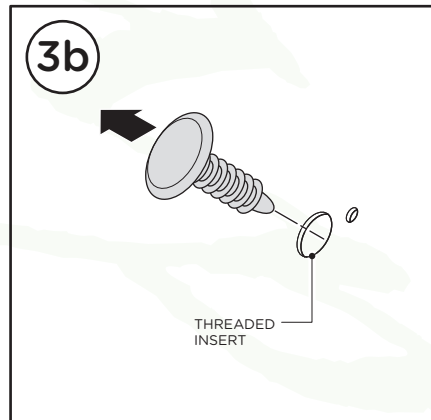
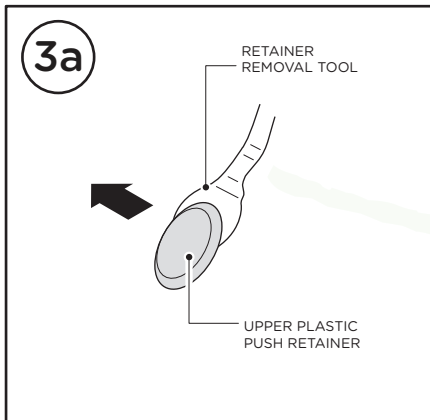

Pull the lower Plastic Push Retainer out of the rocker panel to expose threaded holes that will be used for bracket installation.

Insert each M8 U-Nut Clip into existing holes in rocker panel, making sure the treads are on the inside of the rocker panel.

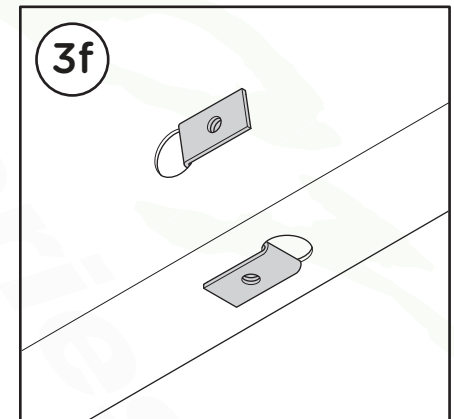
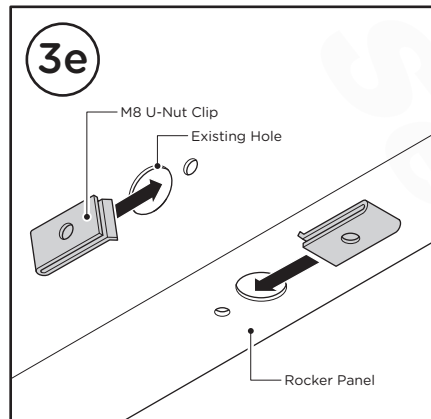
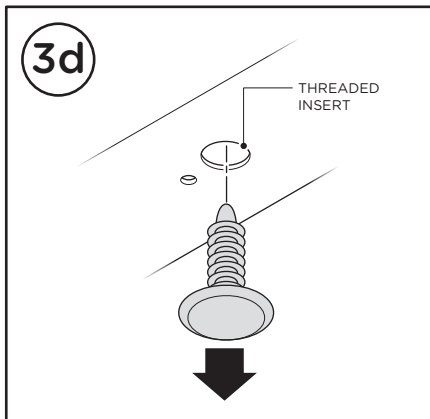

BRACKET INSTALLATION

DRIVER SIDE

Raptor
Series

4. Fasten the top portion of the Driver Side Front Bracket by using (1) M8 x 30 MM Hex Head Bolt, (1) M8 Flat Washer and (1) M8 Lock Washer.

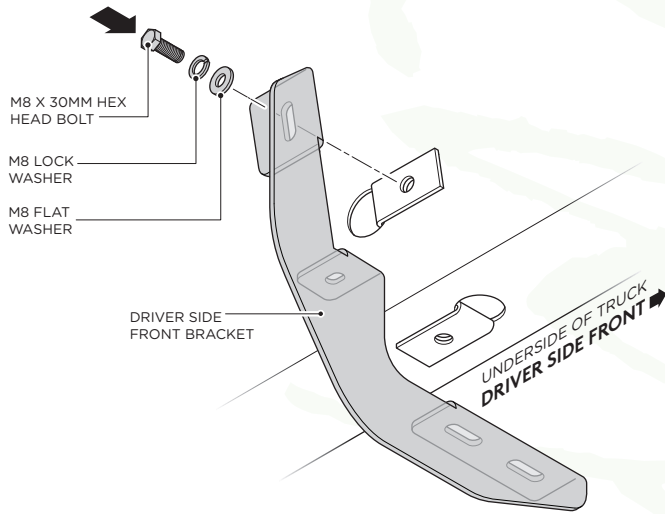

5. Fasten the bottom portion of the Driver Side Front Bracket by using (1) M8 x 30MM Hex Head Bolt, (1) M8 Flat Washer and (1) M8 Lock Washer.

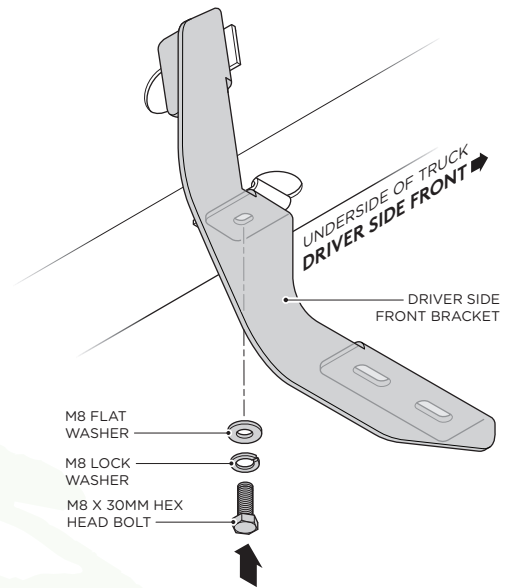

6. Fasten the top portion of the Driver Side Center Bracket by using (1) M8 x 30MM Hex Head Bolt, (1) M8 Flat Washer and (1) M8 Lock Washer.

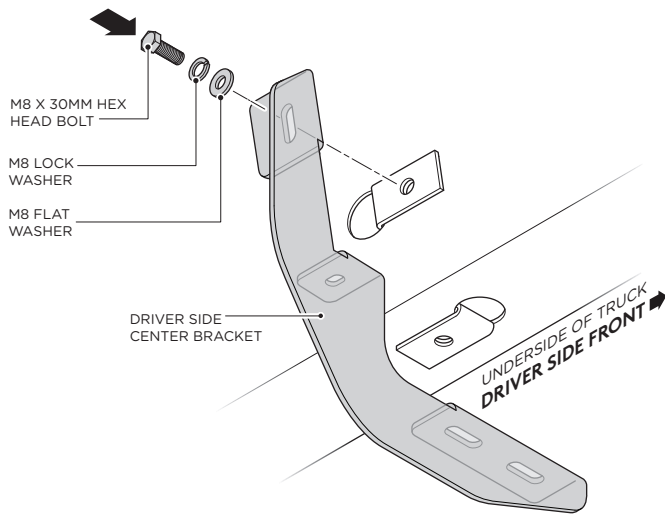

7. Fasten the bottom portion of the Driver Side Center Bracket by using (1) M8 x 30MM Hex Head Bolt, (1) M8 Flat Washer and (1) M8 Lock Washer.

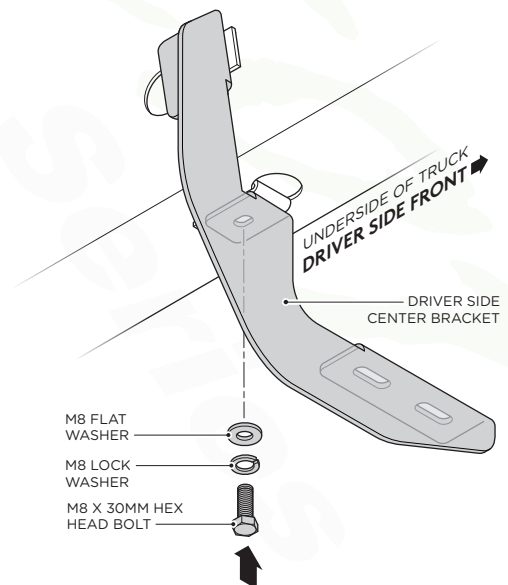

BRACKET INSTALLATION

DRIVER SIDE

Raptor
Series

8. Fasten the top portion of the Driver Side Rear Bracket by using (1) M8 x 30MM Hex Head Bolt, (1) M8 Flat Washer and (1) M8 Lock Washer.

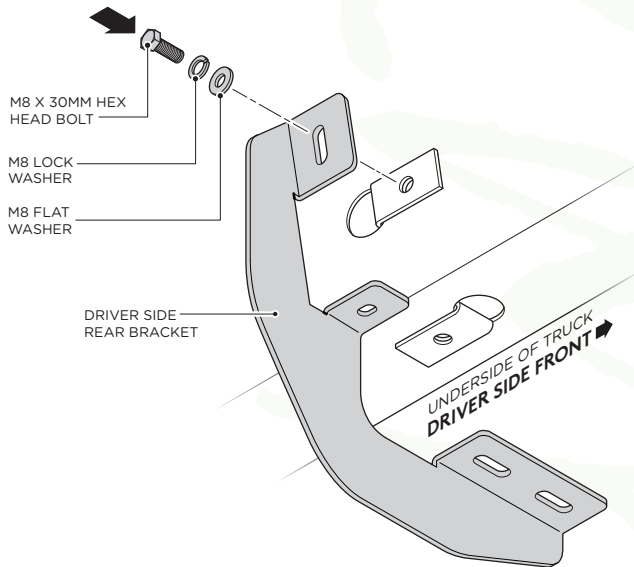

9. Fasten the bottom portion of the Driver Side Rear Bracket by using (1) M8 x 30MM Hex Head Bolt, (1) M8 Flat Washer and (1) M8 Lock Washer.

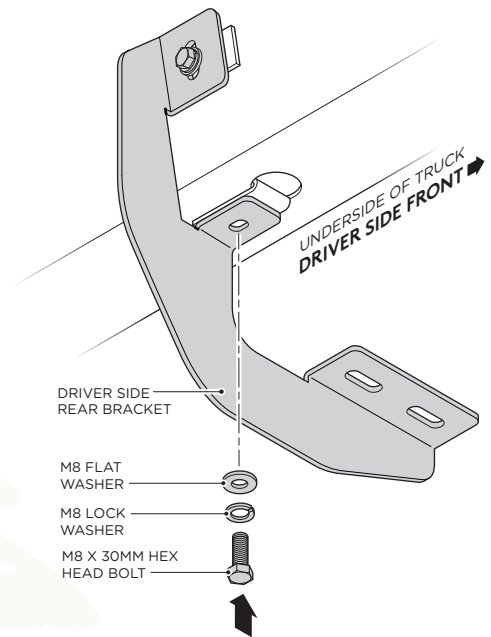

RUNNING BOARD INSTALLATION

DRIVER SIDE

Raptor
Series

- 10.** Fasten the Running Board to the Driver Side Front Bracket cradle by using (2) M8 Flat Washers, (2) M8 Lock Washers and (2) M8 Hex Head Nuts.

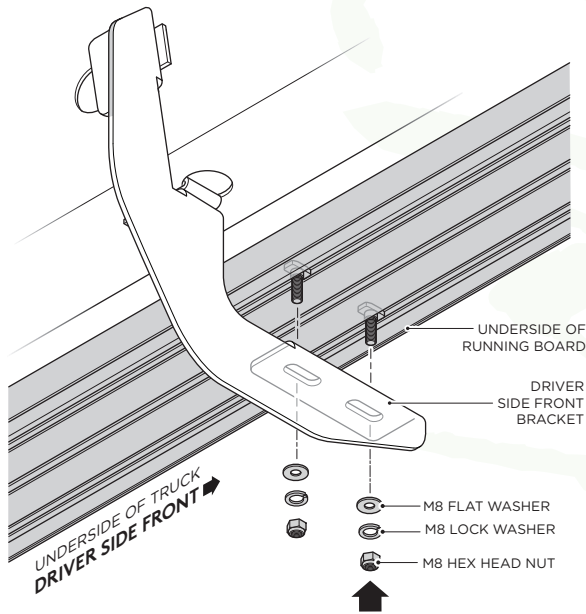

- 11.** Fasten the Running Board to the first Driver Side Center Bracket cradle by using (2) M8 Flat Washers, (2) M8 Lock Washers and (2) M8 Hex Head Nuts.

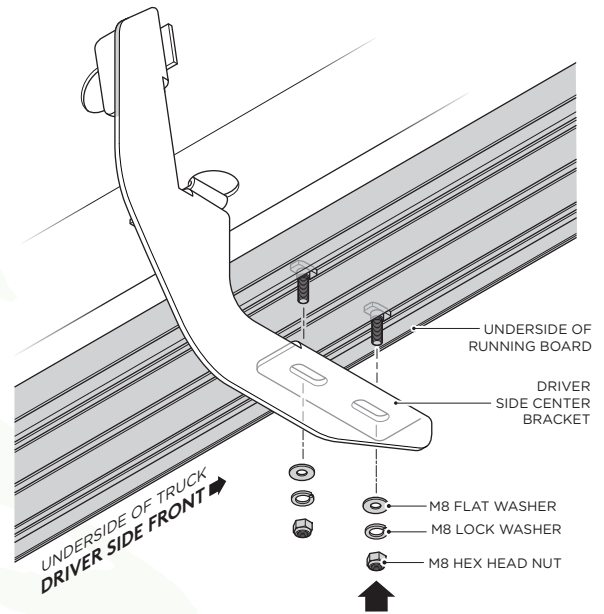

- 12.** Fasten the Running Board to the Driver Side Rear Bracket cradle by using (2) M8 Flat Washers, (2) M8 Lock Washers and (2) M8 Hex Head Nuts.

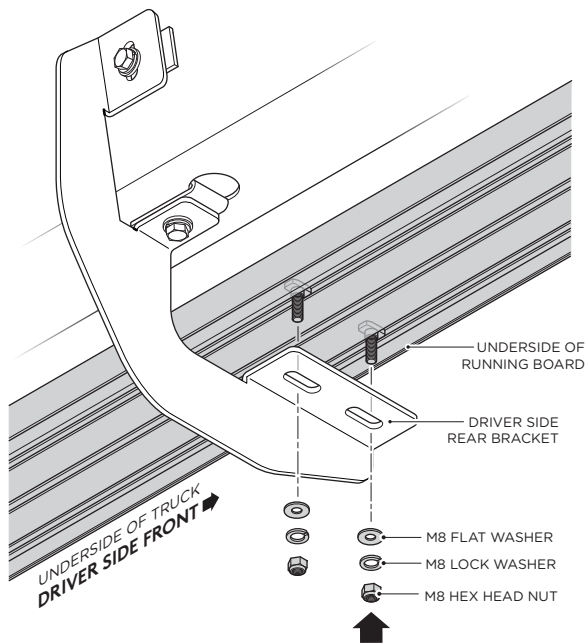

BRACKET ORIENTATION

PASSENGER SIDE

Raptor
Series

1. Begin installation on passenger side. Position the Front Bracket, Center Bracket and Rear Bracket as shown in diagram.

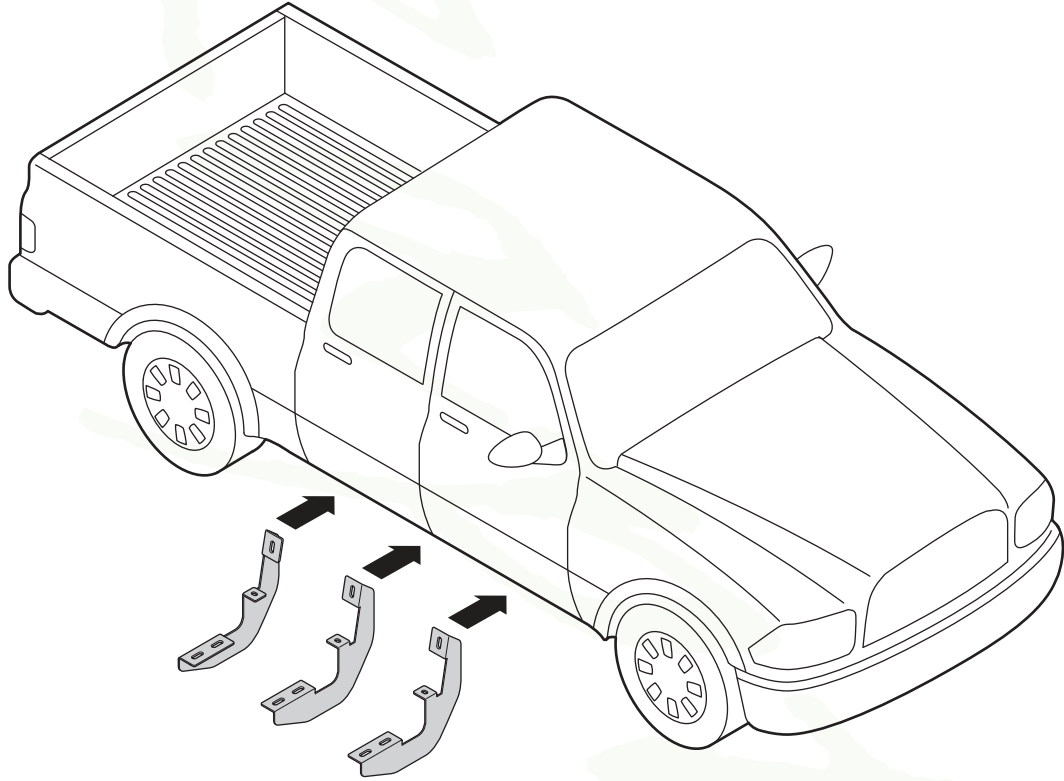

2. Passenger Side Front Bracket cradle (2a) and Passenger Side Center Bracket cradle (2b), will face towards the rear and Passenger Side Rear Bracket cradle (2d) will face towards the front of the truck.

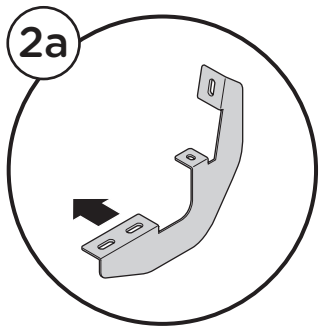

Driver Side
Front Bracket

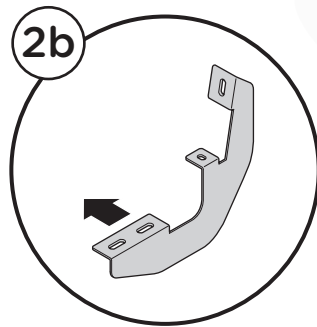

Driver Side
Center Bracket

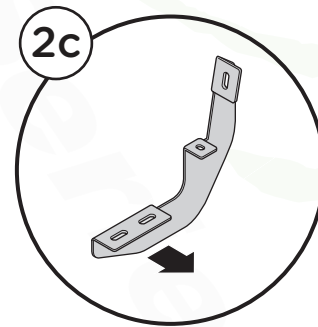

Driver Side
Rear Bracket

PLASTIC PUSH RETAINER REMOVAL

PASSENGER SIDE



NOTE: Removal of Plastic Push Retainer is needed to expose factory holes.

3. Follow the steps shown below to show removal of the upper and lower Plastic Push Retainers and installation of M8 U-Nuts.

Use Retainer Removal Tool to grab underneath the upper Plastic Push Retainer in the rocker panel.

Pull the upper Plastic Push Retainer out of the rocker panel to expose threaded holes that will be used for bracket installation.

Use Retainer Removal Tool to grab underneath the lower Plastic Push Retainer in the rocker panel.

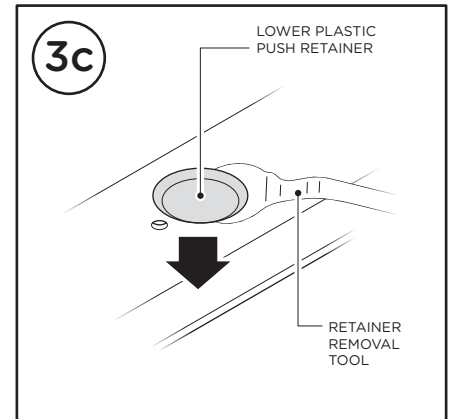
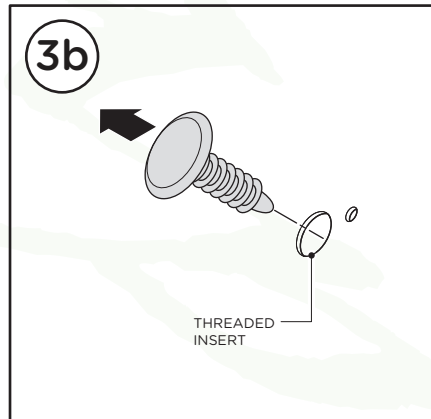
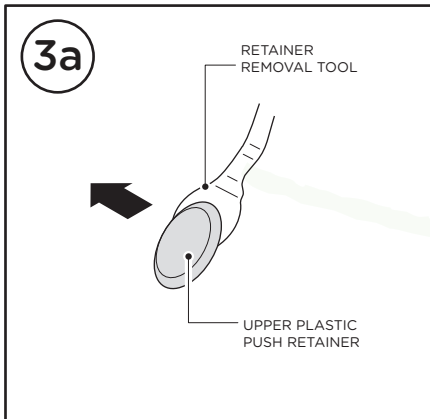

Pull the lower Plastic Push Retainer out of the rocker panel to expose threaded holes that will be used for bracket installation.

Insert each M8 U-Nut Clip into existing holes in rocker panel, making sure the treads are on the inside of the rocker panel.

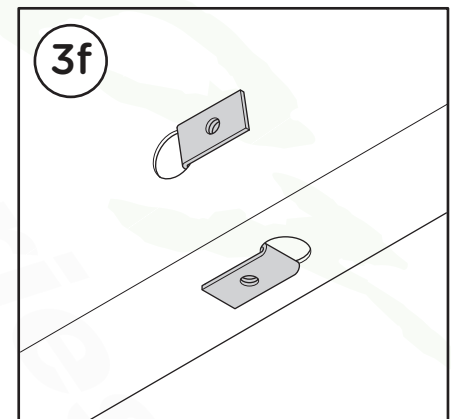
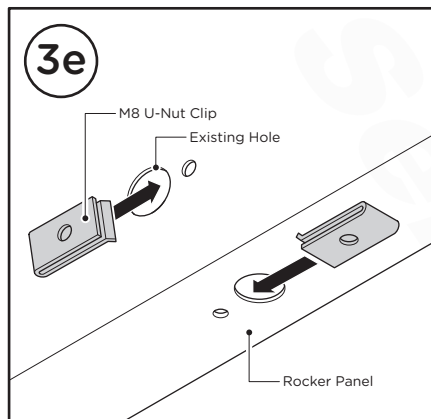
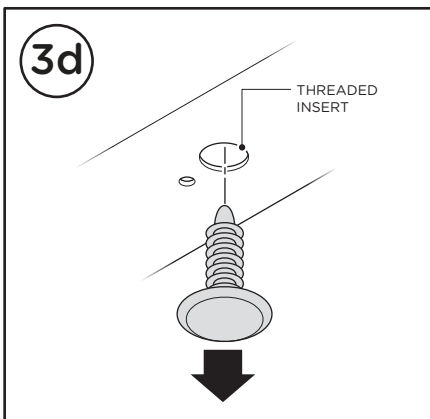

BRACKET INSTALLATION

PASSENGER SIDE

Raptor
Series

4. Fasten the top portion of the Passenger Side Front Bracket by using (1) M8 x 30 MM Hex Head Bolt, (1) M8 Flat Washer and (1) M8 Lock Washer.

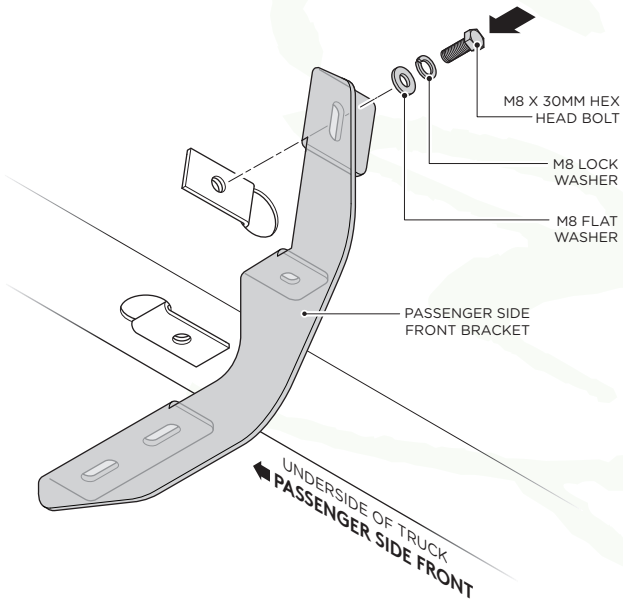

5. Fasten the bottom portion of the Passenger Side Front Bracket by using (1) M8 x 30MM Hex Head Bolt, (1) M8 Flat Washer and (1) M8 Lock Washer.

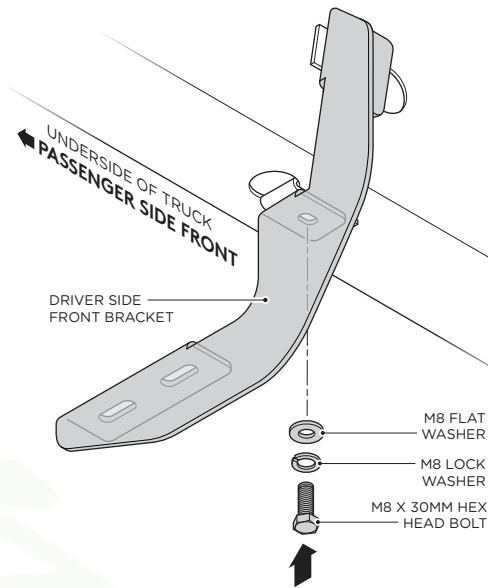

6. Fasten the top portion of the Passenger Side Center Bracket by using (1) M8 x 30MM Hex Head Bolt, (1) M8 Flat Washer and (1) M8 Lock Washer.

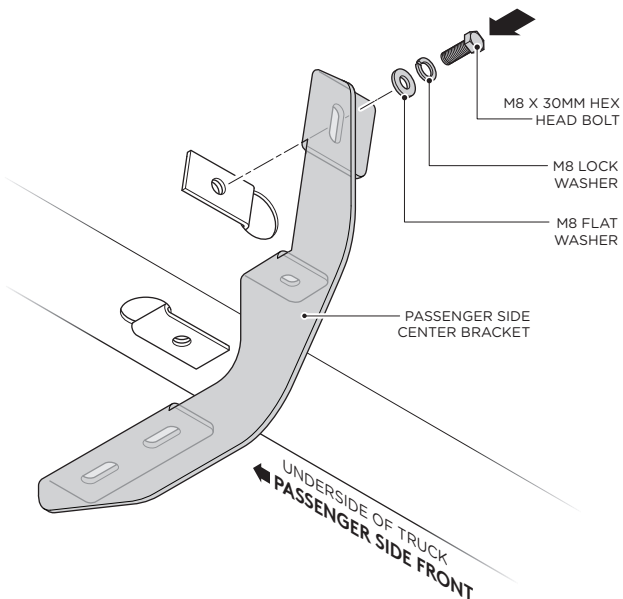

7. Fasten the bottom portion of the Passenger Side Center Bracket by using (1) M8 x 30MM Hex Head Bolt, (1) M8 Flat Washer and (1) M8 Lock Washer.

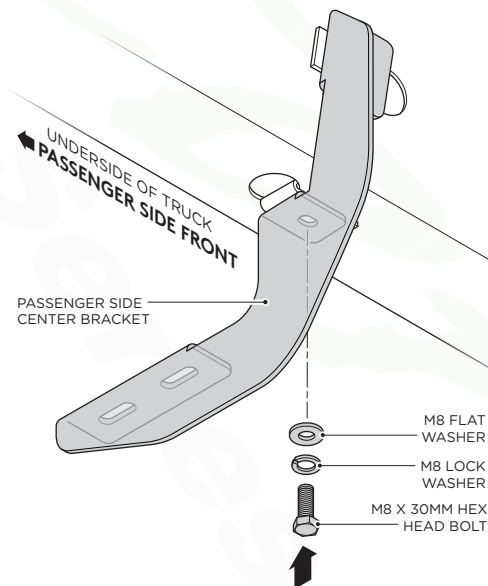

BRACKET INSTALLATION

PASSENGER SIDE

Raptor
Series

8. Fasten the top portion of the Passenger Side Rear Bracket by using (1) M8 x 30MM Hex Head Bolt, (1) M8 Flat Washer and (1) M8 Lock Washer.

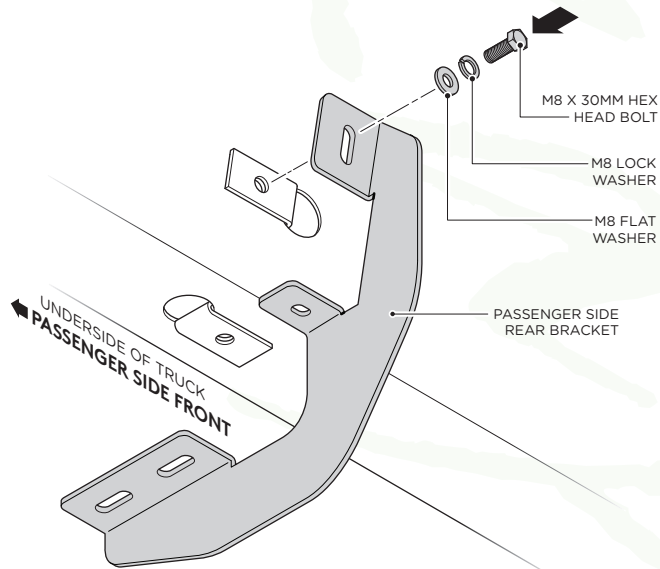

9. Fasten the bottom portion of the Passenger Side Rear Bracket by using (1) M8 x 30MM Hex Head Bolt, (1) M8 Flat Washer and (1) M8 Lock Washer.

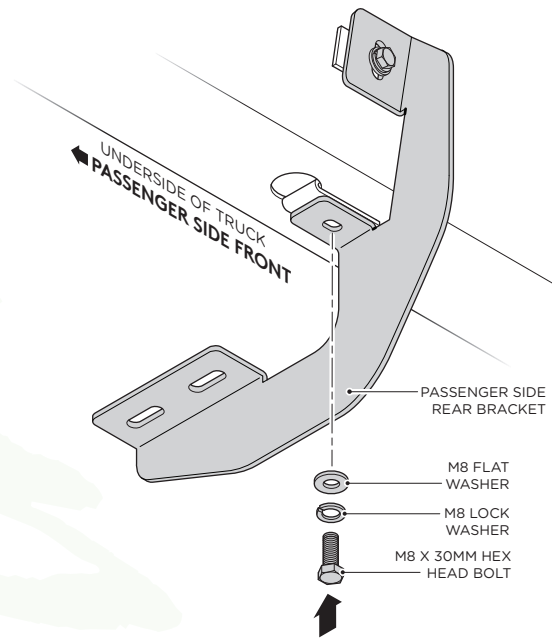

RUNNING BOARD INSTALLATION

PASSENGER SIDE



- 10.** Fasten the Running Board to the Passenger Side Front Bracket cradle by using (2) M8 Flat Washers, (2) M8 Lock Washers and (2) M8 Hex Head Nuts.

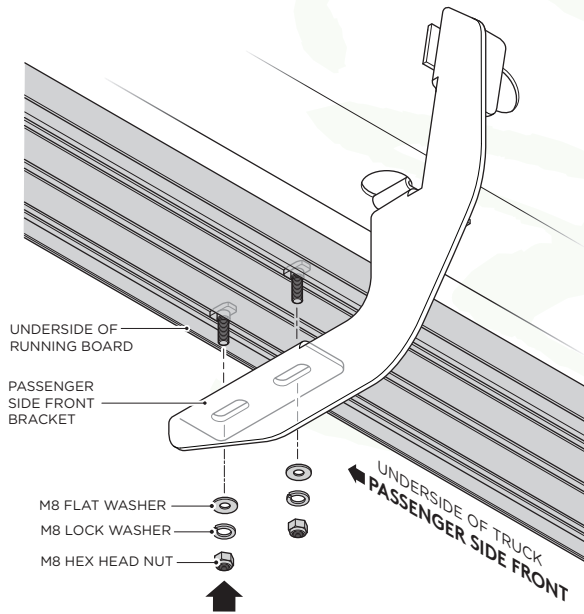

- 11.** Fasten the Running Board to the Passenger Side Center Bracket cradle by using (2) M8 Flat Washers, (2) M8 Lock Washers and (2) M8 Hex Head Nuts.

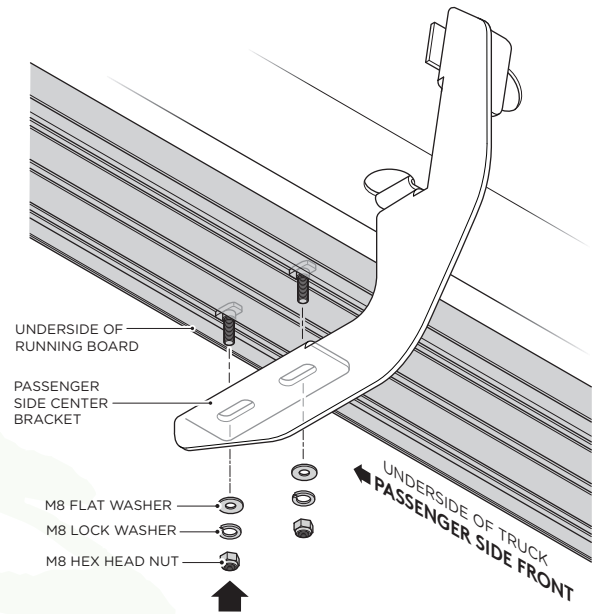

- 12.** Fasten the Running Board to the Passenger Side Rear Bracket cradle by using (2) M8 Flat Washers, (2) M8 Lock Washers and (2) M8 Hex Head Nuts.

