

BRACKET KIT INSTALLATION

SKU# WS-0200-BK



COMPONENTS		HARDWARE	
<p>DRIVER SIDE</p> <p>Qty: 1 Front Bracket</p> <p>Qty: 1 Rear Bracket</p> <p>Qty: 1 Front Support Brace</p> <p>Qty: 1 Rear Support Brace</p>	<p>PASSENGER SIDE</p> <p>Qty: 1 Front Bracket</p> <p>Qty: 1 Rear Bracket</p> <p>Qty: 1 Front Support Brace</p> <p>Qty: 1 Rear Support Brace</p>	<p>Qty: 20 M8 x 30MM Hex Head Bolts</p> <p>Qty: 4 M8 x 35MM Hex Head Bolts</p> <p>Qty 4 M8 Bolt+M8 Nut Plate</p> <p>Qty 4 M8 Bolt Plate</p>	<p>Qty: 28 M8 Flat Washers</p> <p>Qty: 28 M8 Lock Washers</p> <p>Qty: 24 M8 Hex Head Nuts</p> <p>Qty: 4 Plastic Retainer</p>
TOOLS REQUIRED		INSTALLATION NOTES	
<p>RATCHET</p> <p>TORQUE WRENCH</p> <p>13MM SOCKET</p>	<p>TORQUE NOTE: Bolts and nuts should be torqued to 15-20 ft lbs.</p> <p>NOTE: Hardware for Bracket & Board Installation is included.</p> <p>NOTE: Some spare hardware may be included.</p>		

Remove all contents from the package and check brackets for any damage. Also, verify that all components and hardware listed above are included before you begin installation. If anything is missing or damaged please contact us at customerservice@cyc-engineering.com

Read through entire installation manual and installation drawings to ensure that you understand all of the components and hardware before proceeding with installation.

NOTE: When installing the brackets, all hardware must be left loose until all of the items are attached.

Locate factory hole locations in three (2) places per side on the body mount.

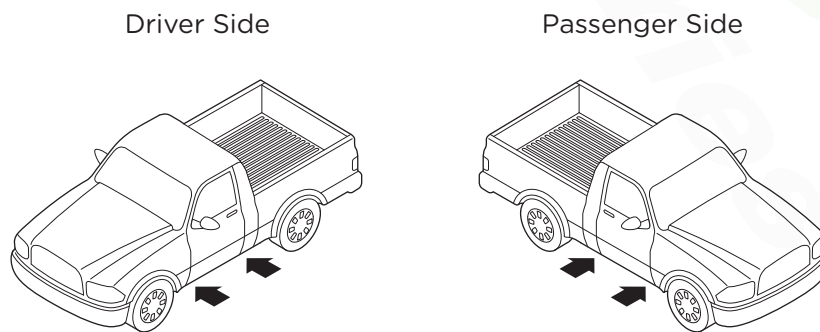

BRACKET ORIENTATION

SKU# WS-0200-BK

Raptor
Series

1. Begin installation on driver side. Position the Front Bracket, Center Bracket and Rear Bracket as shown in diagram.

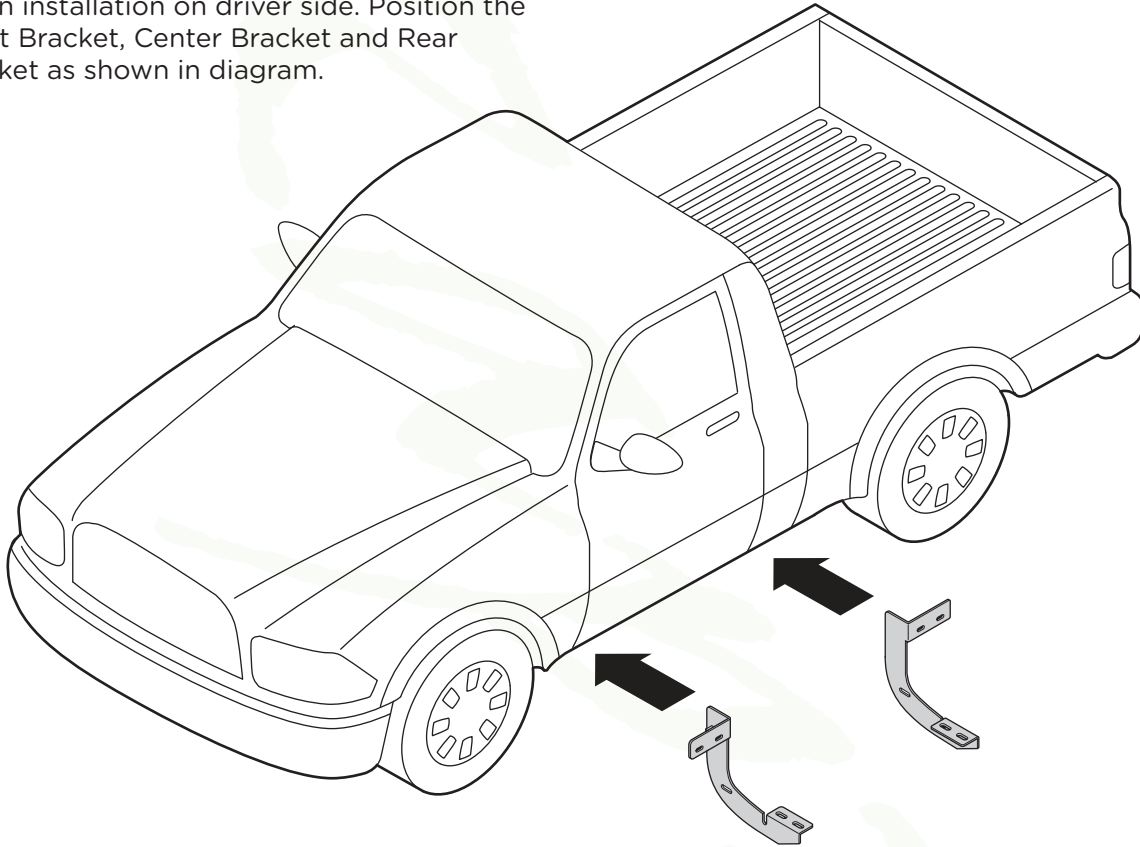

2. Driver Side Front Bracket cradle (2a) will face to the rear of the truck, and Driver Side Rear Bracket cradles (2b) will face toward the front of the truck.

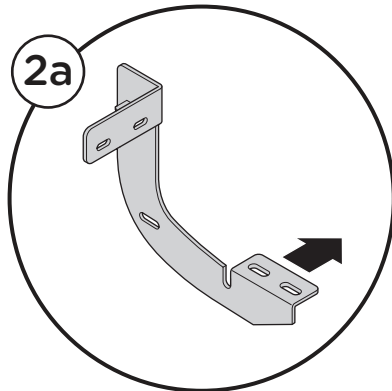

Driver Side
Front Bracket

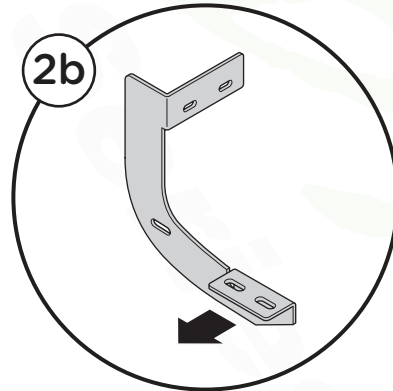

Driver Side
Rear Bracket

BRACKET INSTALLATION (WITH THREADED INSERTS)

SKU# WS-0200-BK



If threaded inserts already exist in your rocker panel holes, proceed with Step 3.
If threaded inserts do not exist in your rocker panel holes, skip to Step 5 on Page 4.

- 3.** Fasten the top portion of the Driver Side Front Bracket by using (2) M8 x 30MM Hex Head Bolts, (2) M8 Flat Washers and (2) M8 Lock Washers.

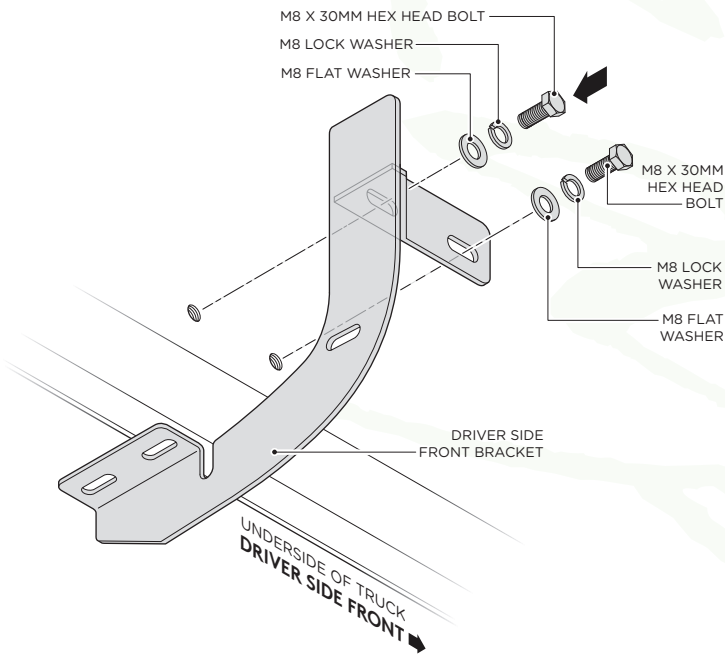

- 4.** Fasten the top portion of the Driver Side Rear Bracket by using (2) M8 x 30MM Hex Head Bolts, (2) M8 Flat Washers and (2) M8 Lock Washers.

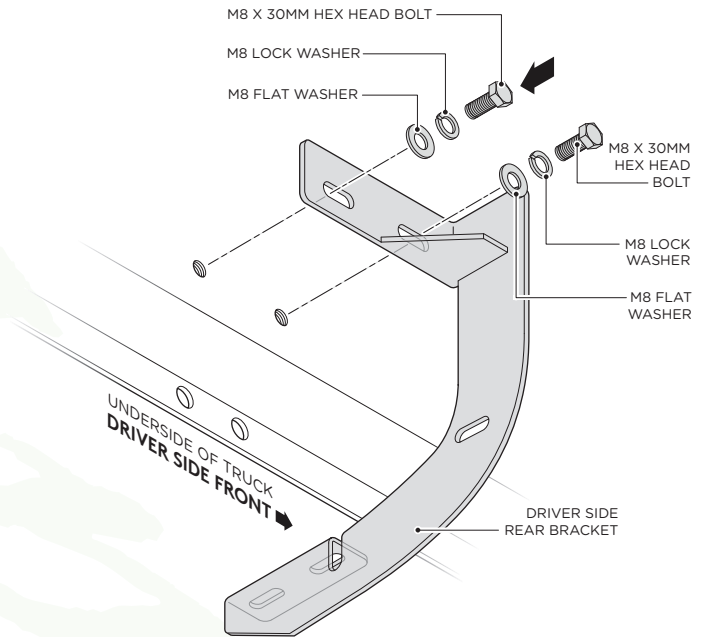

M8 BOLT + M8 NUT PLATE INSTALLATION

SKU# WS-0200-BK



If threaded inserts do not exist in your rocker panel holes, proceed with Step 5.

NOTE: Removal of tape or plastic plugs may be needed to expose factory holes.

NOTE: Use caution to not drop any hardware into your rocker panel!

5. Follow the steps shown below to install the M8 Bolt + M8 Nut Plate.

Insert M8 Bolt + M8 Nut Plate into top hole as shown.

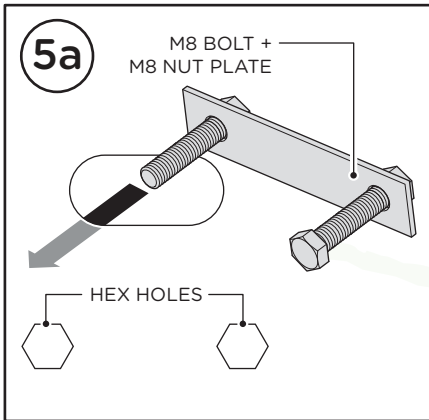

Rotate the threaded side of the M8 Bolt + M8 Nut Plate to the bottom left hole.

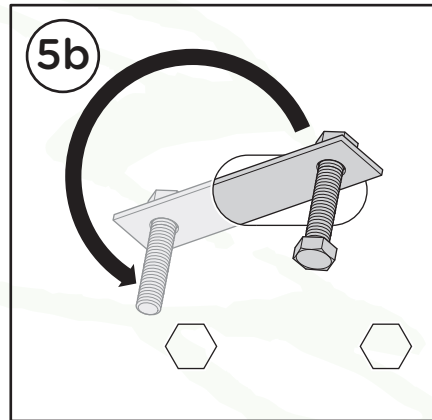

Pull the threaded side of the M8 Bolt + M8 Nut Plate through the bottom left hole.

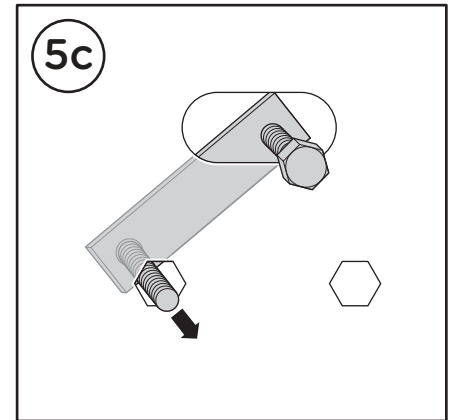

Install Plastic Retainer to ensure you do not drop the M8 Bolt + M8 Nut Plate into the rocker panel.

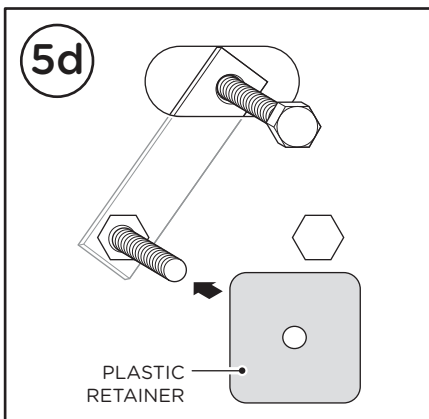

Remove the M8 Bolt from the M8 Nut Plate.

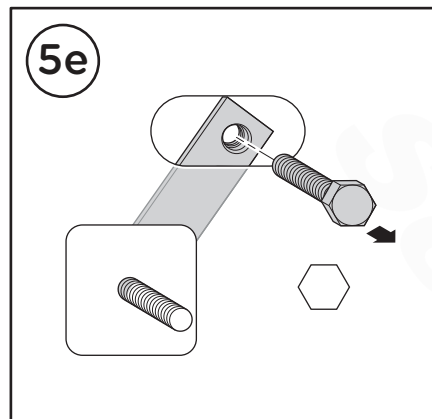

The M8 Nut Plate will now be able to rotate down to the hole in the rocker panel, allowing for bracket installation.

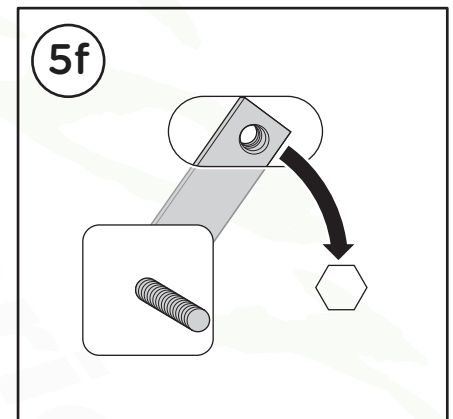

BRACKET INSTALLATION (WITHOUT THREADED INSERTS)

SKU# WS-0200-BK



- 6.** Fasten the top portion of the Driver Side Front Bracket to the bolt side of the M8 Bolt + M8 Nut Plate by using (1) M8 Flat Washer, (1) M8 Lock Washer and (1) M8 Hex Head Nut. Next, install the (1) M8 x 35MM Hex Head Bolt, (1) M8 Lock Washer and (1) M8 Flat Washer to the nut side of the M8 Bolt + M8 Nut Plate.

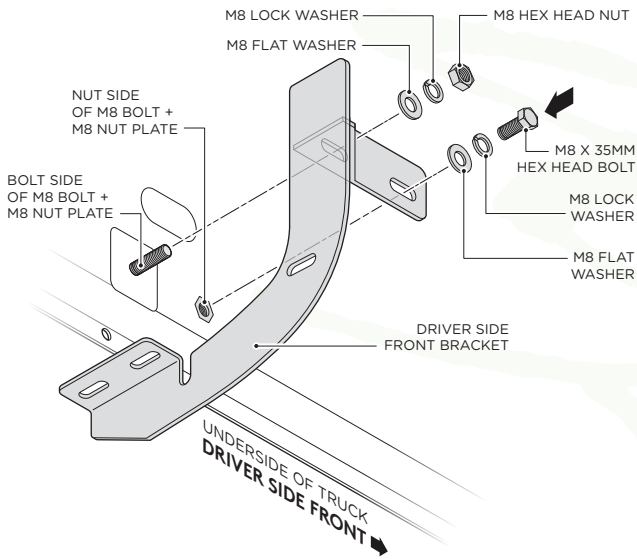

- 7.** Fasten the top portion of the Driver Side Rear Bracket to the bolt side of the M8 Bolt + M8 Nut Plate by using (1) M8 Flat Washer, (1) M8 Lock Washer and (1) M8 Hex Head Nut. Next, install the (1) M8 x 35MM Hex Head Bolt, (1) M8 Lock Washer and (1) M8 Flat Washer to the nut side of the M8 Bolt + M8 Nut Plate.

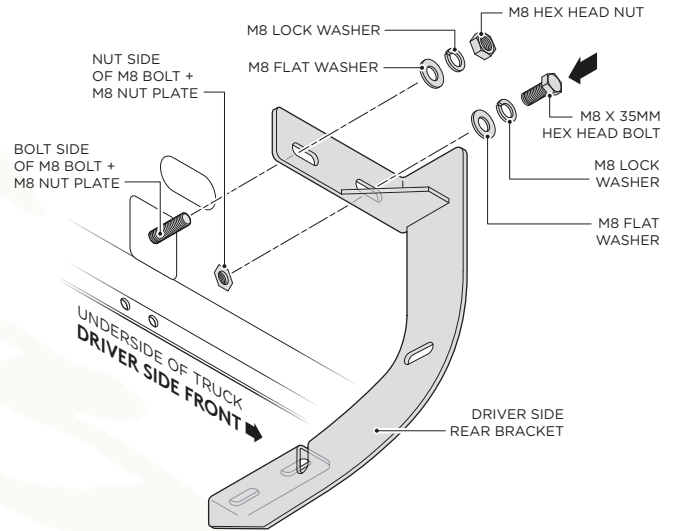

SUPPORT BRACE INSTALLATION

SKU# WS-0200-BK

Raptor
Series

8. Fasten the top of the Driver Side Front Support Brace to the rocker panel using (2) M8 x 30MM Hex Head Bolts, (2) M8 Flat Washers, (2) M8 Lock Washers and (2) M8 Hex Head Nuts. Then, fasten the bottom of the Driver Side Front Support Brace to the Driver Side Front Bracket using (1) M8 x 30MM Hex Head Bolt (2) M8 Flat Washers, (1) M8 Lock Washer and (1) M8 Hex Head Nut.

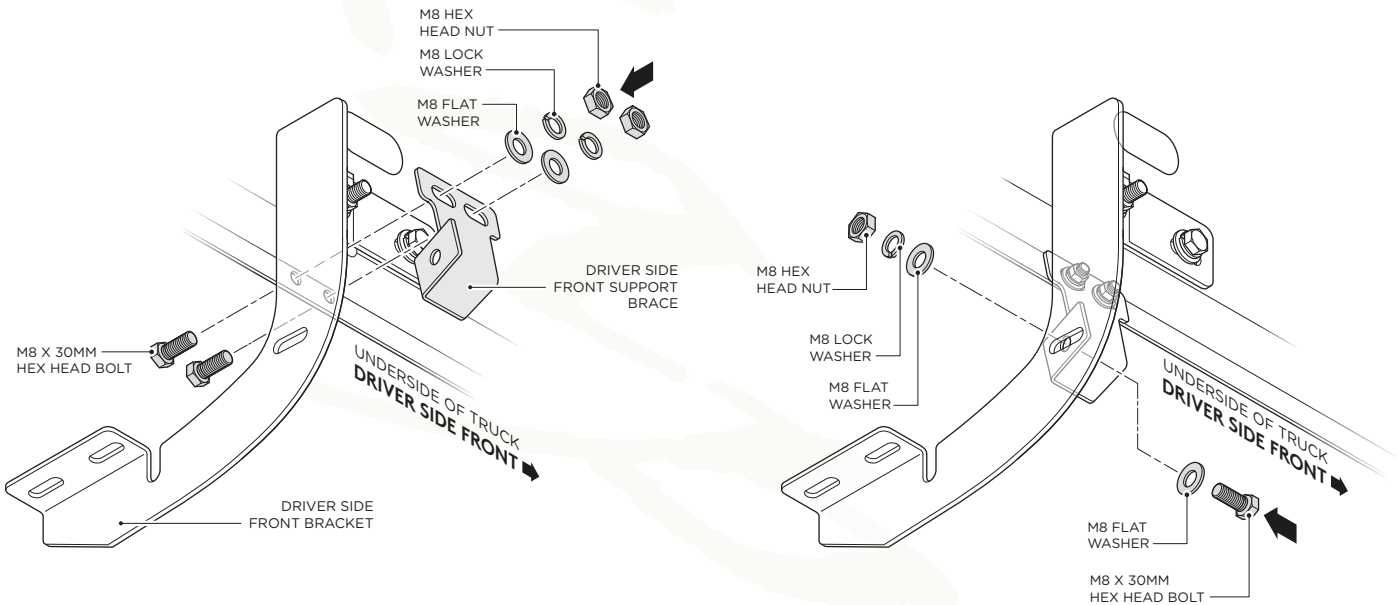

9. Fasten the top of the Driver Side Rear Support Brace to the rocker panel using (2) M8 x 30MM Hex Head Bolts, (2) M8 Flat Washers, (2) M8 Lock Washers and (2) M8 Hex Head Nuts. Then, fasten the bottom of the Driver Side Rear Support Brace to the Driver Side Rear Bracket using (1) M8 x 30MM Hex Head Bolt (2) M8 Flat Washers, (1) M8 Lock Washer and (1) M8 Hex Head Nut.

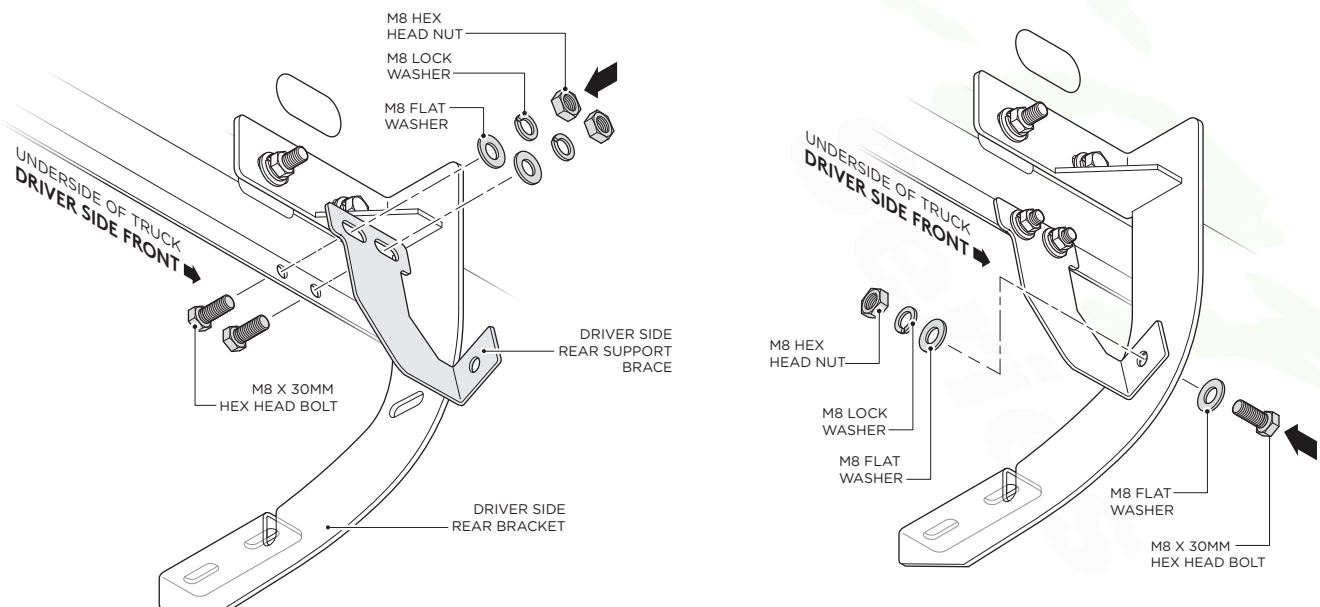

RUNNING BOARD INSTALLATION

SKU# WS-0200-BK

Raptor
Series

- 10.** Insert M8 Bolt Plate into bottom of the Running Board as shown, then fasten the to the Driver Side Front Bracket cradle by using (2) M8 Flat Washers, (2) M8 Lock Washers and (2) M8 Hex Head Nuts.

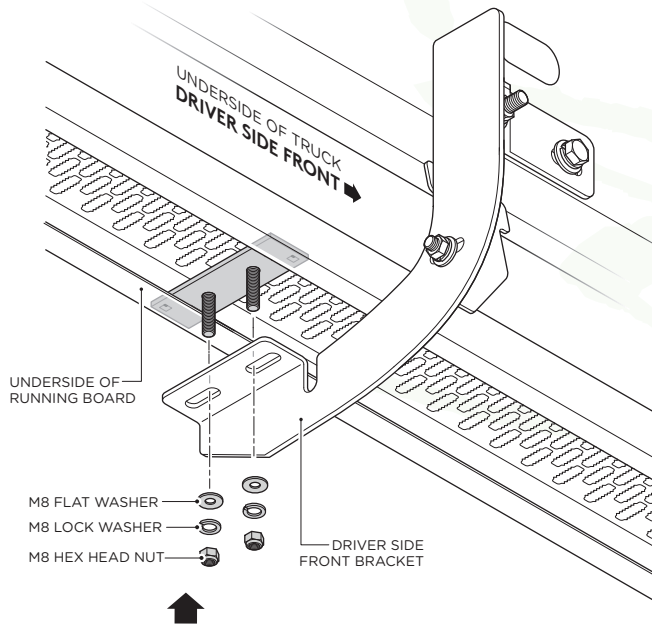

- 11.** Insert M8 Bolt Plate into bottom of the Running Board as shown, then fasten the to the Driver Side Rear Bracket cradle by using (2) M8 Flat Washers, (2) M8 Lock Washers and (2) M8 Hex Head Nuts.

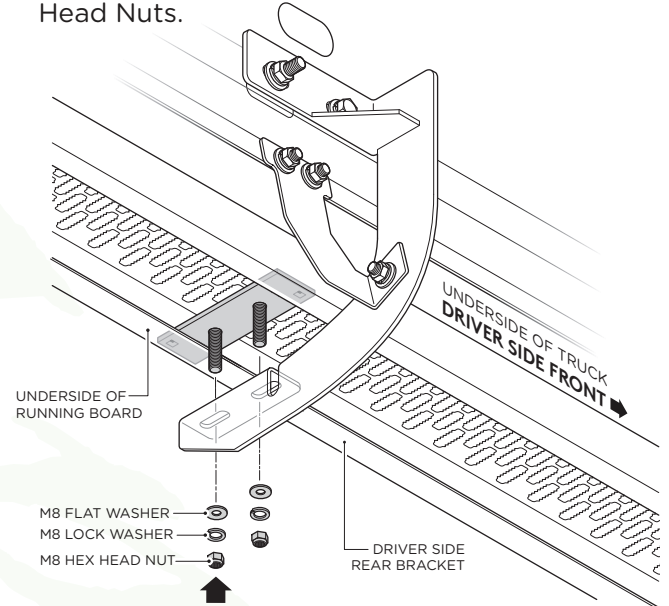

The installation on the Driver Side is now complete. Repeat all previous steps on the passenger side of the vehicle.