

INSTALLATION MANUAL

206180

Level of Difficulty

Easy

Parts List

1	Grille guard*
1	Driver / left mounting bracket
1	Passenger / right mounting bracket
2	Tow hook mounting bracket
8	Spacer
1	Magnet assembly
1	Magnet assembly with safety pin
2	Hex bolt, 7/8"-9 x 3"
2	Hex bolt, 7/8"-9 x 3-1/2"
2	Hex bolt, 5/8"-11 x 1-3/4"
2	Shoulder bolt, 5/8" x 7/8" x 1/2"-13
2	Lock washer, 7/8"
2	Flat washer, 5/8"
4	Belleville washer, .63" x 1.25" x .04" x .042"
2	Nylock nut, 5/8"-11
2	Nylock nut, 1/2"-13

*Grille guard sold separately

Tools Required

Ratchet	Socket, 15/16"
Torque wrench	Socket, 1-5/16"
Wrench, 15/16"	Socket, 3/4"
Allen wrench, 5/16"	--

Torque Specifications

1/2" bolt	65 ft-lbs.
5/8" bolt	128 ft-lbs.
3/4" bolt	228 ft-lbs.
7/8" bolt	300 ft-lbs.

Use above torque setting unless otherwise noted

Product Photo

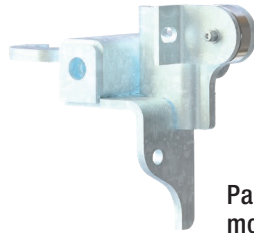

Passenger / right mounting bracket

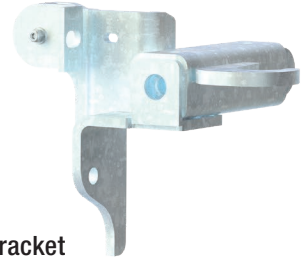

Driver / left mounting bracket

CAUTION

Strong magnets may produce pinch hazards and may be harmful to pacemakers and other sensitive electronics.

NOTICE

Before you begin installation, read all instructions thoroughly.

Proper tools will improve the quality of installation and reduce the time required.

To help prevent damage to the product or vehicle, refer to the specified torque specifications when securing hardware during the installation process.

Maintenance

To protect the product, wax after installing. Regular waxing is recommended to add a protective layer over the finish. Do not use any type of polish or wax that may contain abrasives that could damage the finish.

For polished, gloss and other smooth finishes, polish may be used to clear small scratches and scuffs on the finish.

Mild automotive detergent may be used to clean the product. Do not use dish detergent, abrasive cleaners, abrasive pads, wire brushes or other similar products that may damage the finish.

Step 1

If installing on VNR, skip to step 2.

Remove the tow hook cover panel by pulling straight out on the upper outside of the truck corner of the tow hook cover panel. Pull the panel out of the tab holes once the cover pops out of the fastener securing it.



Step 2

Remove the factory tow hook pins if installed.

VNL – Slide four spacers over the tow hook bracket from the opposite side of the welded nut. Insert the mounting bar into the tow hook opening and install the factory tow hook pin.

VNR – Insert the mounting bar into the tow hook opening and install the factory tow hook pin.

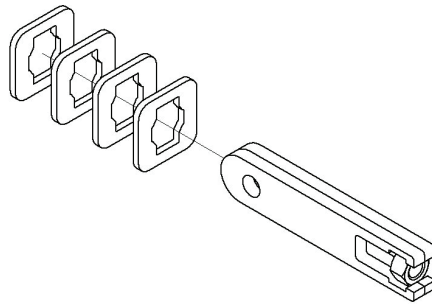

Step 3

VNL – Slide the mounting brackets over each tow hook mounting bar and insert a 7/8"-9 x 3-1/2" hex bolt with 7/8" lock washer into the mounting bar bracket nut.

Snug the hardware, but do not fully tighten.

VNR – Slide the mounting bracket over each tow hook mounting bar and insert a 7/8"-9 x 3" hex bolt with 7/8" lock washer into the mounting bar bracket nut.

Snug the hardware, but do not fully tighten.

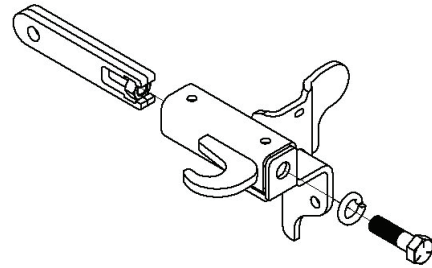

Step 4

Starting on the driver side, use a 5/16" allen wrench and 3/4" socket to secure the guard to the mounting brackets with a 5/8" x 7/8" shoulder bolt, two .63" x 1.25" x .040" x .082" belleville washers (large diameter to the guard bracket face) and a 1/2"-13 nylock nut. Use the bottom holes of the mounting brackets.

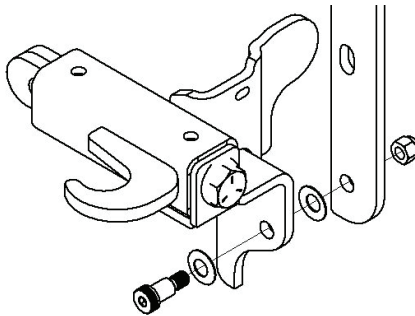

Step 5

Use a 15/16" socket and wrench to secure the magnet bracket assembly to the mounting bracket of the grille guard with a 5/8"-11 x 1-3/4" bolt, 5/8" flat washer and 5/8"-11 nylock nut. The safety pin bracket must be on the driver side.

Repeat steps 4 through 5 on the passenger side.

NOTICE

Magnets and brackets are pre-assembled, some adjustment may be necessary after the grille guard is installed on the truck.

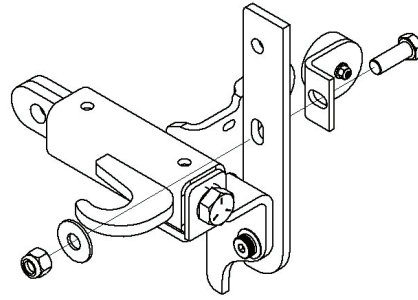

Step 6

Tighten the 7/8" bolts to the recommended torque specification listed in the table on the first page.

Close the guard and check to make sure the magnets line up correctly. Adjust if needed.

Step 7 - VNL Only (Optional)

To use the factory cover panel it will need to be notched out around the mounting brackets. Hold up the cover panel next to the mounting bracket and with masking tape on the panel mark what needs to be removed. Make sure the panel is clean before taping.

Using a cutoff wheel or fine-tooth bladed saw, cut out the marked area. Keep the masking tape on until finished to help protect the paint. A general recommended area to cut out is pictured.

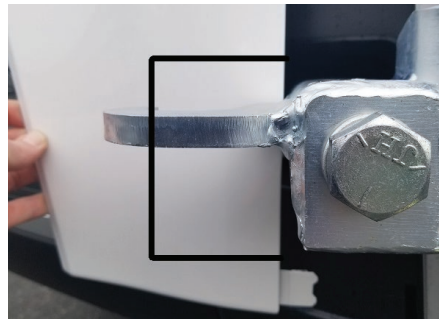

Step 8

With the grill guard installed, periodic inspections should be performed to ensure all mounting hardware remains tight.

To protect your investment, see the 'Notes and Maintenance' section on page one.

Congratulations on the installation of your new RETRAC grille guard.