

INSTALLATION MANUAL

207700

Level of Difficulty

Easy

Parts List

Qty	Description	#
1	Bumper guard	1
1	Driver / left mounting bracket	2
1	Passenger / right mounting bracket	3
2	Tow hook mounting bar	4
4	Hex bolt, M16 x 50mm	5
2	Hex bolt, M16 x 70mm	6
2	Lock washer, M16	7
10	Flat washer, M16	8
4	Nylock nut, M16	9
2	Spacer	10

Tools Required

Ratchet	Cutting tool
Socket, 24mm	Paint marker
Torque wrench, 24mm	Panel trim removal tool

Torque Specifications

Metric		
	M6 bolt	8 ft.-lbs.
	M8 bolt	19 ft.-lbs.
	M10 bolt	37 ft.-lbs.
	M12 bolt	65 ft.-lbs.
	M16 bolt	160 ft.-lbs.

Use above torque setting unless otherwise noted

Product Photo



Brackets and Hardware

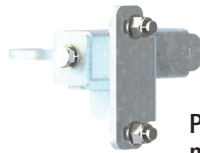

Passenger / right mounting bracket

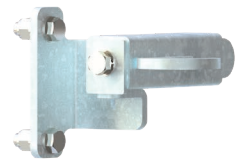

Driver / left mounting bracket

Notes and Maintenance

Before you begin installation, read all instructions thoroughly.

Proper tools will improve the quality of installation and reduce the time required.

To protect the product, wax after installing. Regular waxing is recommended to add a protective layer over the finish. Do not use any type of polish or wax that may contain abrasives that could damage the finish.

For polished, gloss and other smooth finishes, polish may be used to clear small scratches and scuffs on the finish.

Mild automotive detergent may be used to clean the product. Do not use dish detergent, abrasive cleaners, abrasive pads, wire brushes or other similar products that may damage the finish.

Refer to the table to the left when securing hardware during the installation process to help prevent damage to the product or vehicle.

ASSEMBLY

Parts List

Qty	Description	#
1	Bumper guard	1
1	Driver / left mounting bracket	2
1	Passenger / right mounting bracket	3
2	Tow hook mounting bar	4
4	Hex bolt, M16 x 50mm	5
2	Hex bolt, M16 x 70mm	6
2	Lock washer, M16	7
10	Flat washer, M16	8
4	Nylock nut, M16	9
2	Spacer	10

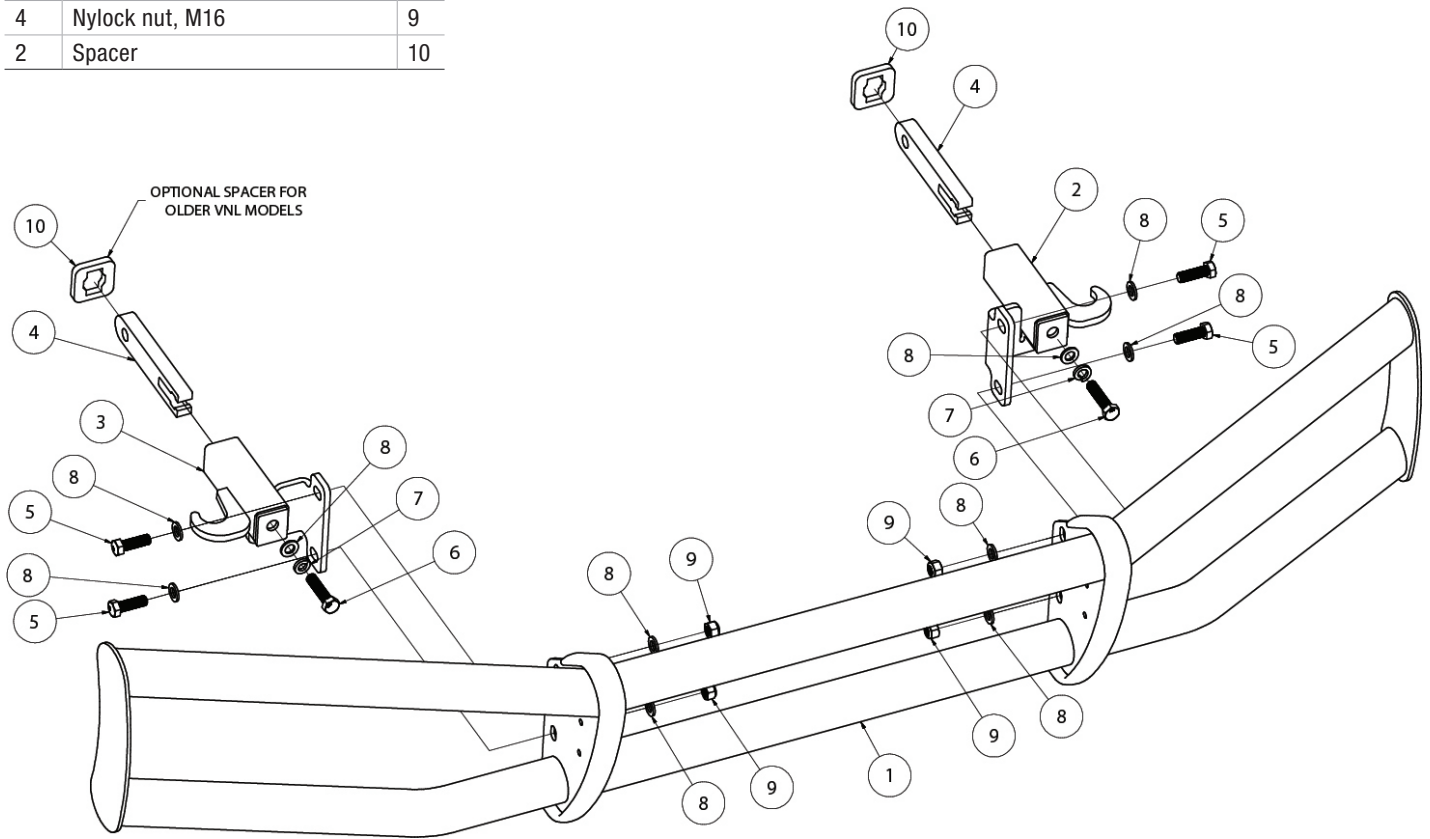

Step 1

Remove the tow hook cover panel by pulling straight out on the upper outside of the truck corner of the tow hook cover panel. Pull the panel out of the tab holes once the cover pops out of the fastener securing it.



Step 2

If installed, remove the factory tow hook pins. Insert the new tow hook mounting bar into the tow hook opening and reinstall the factory tow hook pins.

Note: On older VNL trucks, prior to inserting the tow hook mounting bar into the tow hook opening, slide the spacer onto the tow hook mounting bar from the opposite side of the welded nut.

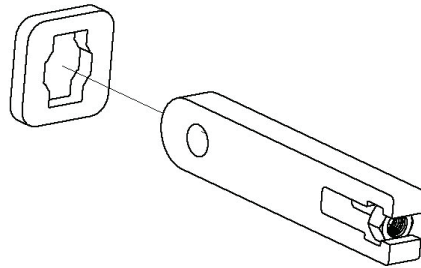

Step 3

Slide the mounting brackets over each tow hook mounting bar and insert an M16 x 70mm bolt M16 lock washer and flat washer into the tow hook mounting bar nut.

Snug the hardware, but do not fully tighten.

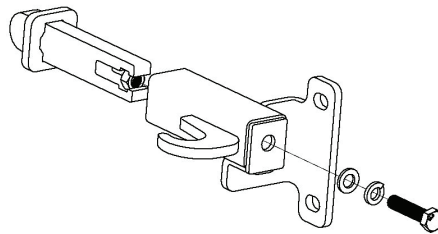

Step 4

Starting on the driver side, secure the guard onto the mounting brackets using two M16 x 50mm bolts, four M16 flat washers and two nylock nuts.

Repeat this step for the passenger side.

Adjust and center the grille guard on the radar as needed.

Note: The hood may rest on the rubber bumpers of the guard.

Tighten all hardware to the recommended torque specifications listed in the table on the first page.

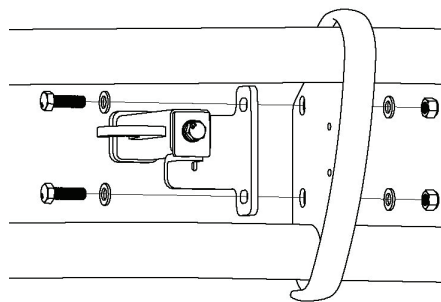

Step 5 (Optional step for newer VNL trucks)

To apply the cover panel, notches will need to be made around the mounting brackets. Hold the cover panel next to the mounting bracket and mark out the area that needs to be removed.

To protect the finish, apply masking tape to the panel and do not remove until the installation is complete. Make sure the panel is clean before taping. Using a cutoff wheel or fine-tooth saw blade, cut out the marked area.

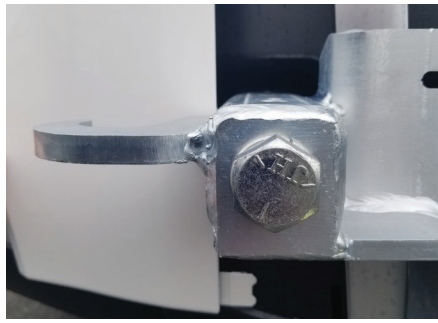

Step 6

Congratulations on the installation of your new RETRAC bumper guard.

With the bumper guard installed, periodic inspections should be performed to ensure all mounting hardware remains tight.

To protect your investment, see the 'Notes and Maintenance' section on the first page of this installation manual.



Representative photo,
actual finish may vary