

# INSTALLATION MANUAL

# 207710

## Level of Difficulty

Easy

## Parts List

Qty	Description	#
1	Light cage	1
4	Hex bolt, M8	2
8	Flat washer, M8	3
4	Nylock nut, M8	4

\* Bumper guard sold separately

## Tools Required

Ratchet	Wrench, 13mm
Socket, 13mm	--

## Torque Specifications

	Metric	SAE
	M6 bolt	3 ft-lbs.
	M8 bolt	7 ft-lbs.
	M10 bolt	16 ft-lbs.
	M12 bolt	28 ft-lbs.
	1/4" bolt	3 ft-lbs.
	5/16" bolt	7 ft-lbs.
	3/8" bolt	16 ft-lbs.
	7/16" bolt	20 ft-lbs.
	1/2" bolt	28 ft-lbs.

Use above torque setting unless otherwise noted

## Product Photo

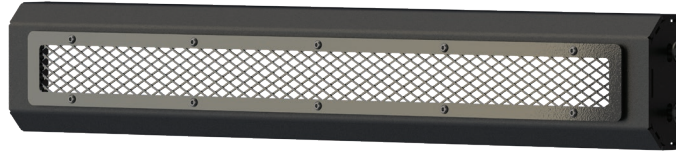

## Notes and Maintenance

Before you begin installation, read all instructions thoroughly.

Proper tools will improve the quality of installation and reduce the time required.

To protect the product, wax after installing. Regular waxing is recommended to add a protective layer over the finish. Do not use any type of polish or wax that may contain abrasives that could damage the finish.

Mild automotive detergent may be used to clean the product. Do not use dish detergent, abrasive cleaners, abrasive pads, wire brushes or other similar products that may damage the finish.

Refer to the table to the left when securing hardware during the installation process to help prevent damage to the product or vehicle.

Covered by U.S. patent# US9108581B2

# ASSEMBLY

## Parts List

Qty	Description	#
1	Light cage	1
4	Hex bolt, M8	2
8	Flat washer, M8	3
4	Nylock nut, M8	4

\*Bumper guard sold separately

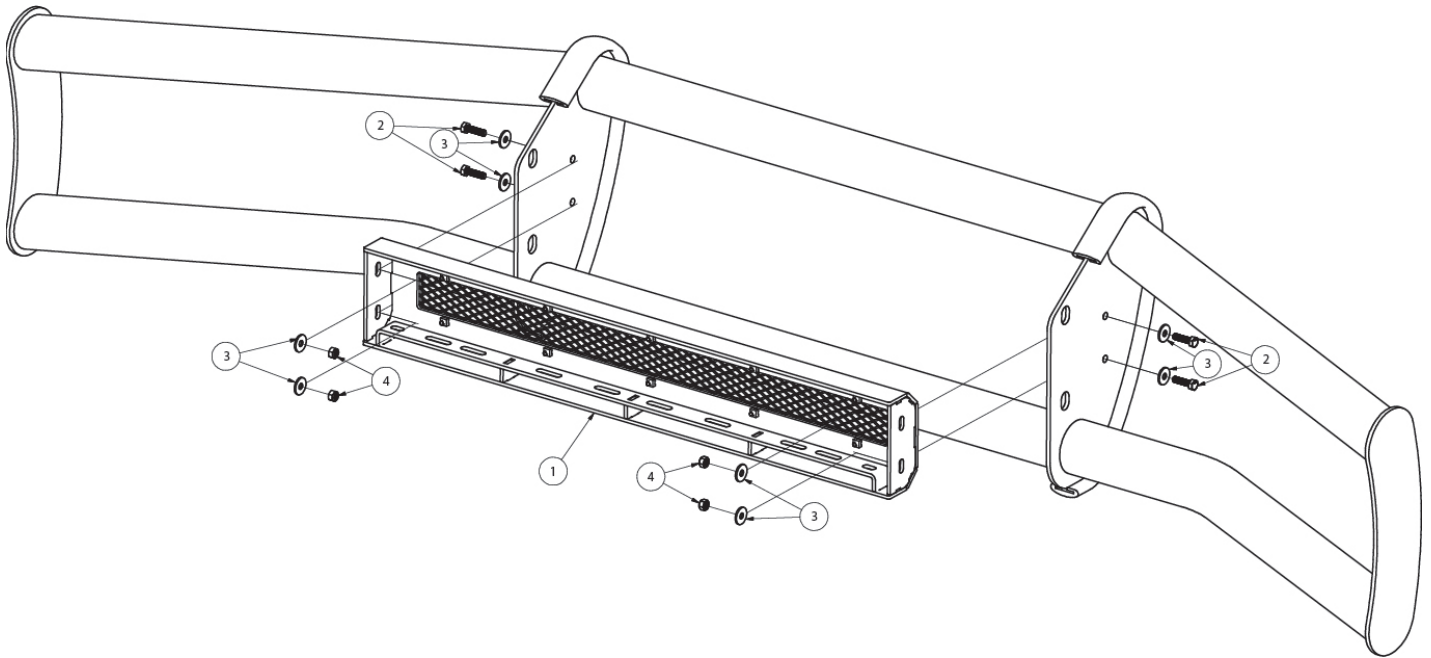

## Step 1

If installed, remove the bumper guard from the truck.

## Step 2

Slide the light cage into place from the back side of the bumper guard with the light mounting bar on the bottom.

Align the holes in the bumper guard uprights.  
Secure with M8 bolts, flat washers and nylock nuts.

**Note:** Some bumper guards may have two sets of holes for middle and lower mounting locations.

## Step 3

Reinstall the bumper guard.