

INSTALLATION MANUAL

207775

Level of Difficulty

Easy

Parts List

#	Qty	Description
1	1	Bumper guard
2	1	Driver / left tow hook bracket
3	1	Passenger / right tow hook bracket
4	1	Driver / left mounting bracket
5	1	Passenger / right mounting bracket
6	2	Adjustable mounting bracket
7	18	Hex bolt, M16
8	36	Flat washer, M16
9	18	Nylock nut, M16

Tools Required

Ratchet	Socket, 24mm
Wrench, 24mm	Socket, 3/4"
Wrench, 3/4"	Socket, 15/16"
Wrench, 15/16"	--

Torque Specifications

M16 bolt	160 ft-lbs.
Use above torque setting unless otherwise noted	

Product Photo

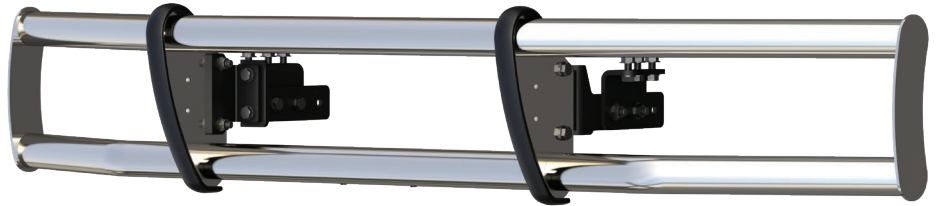

Brackets and Hardware

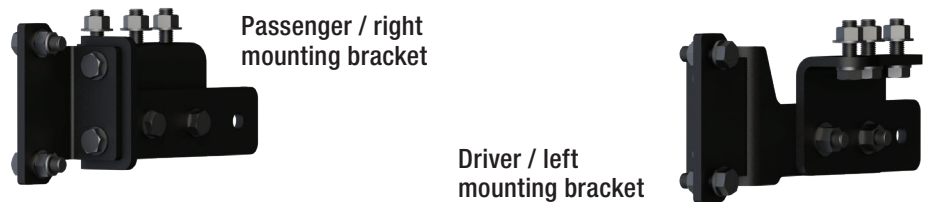

NOTICE

Before you begin installation, read all instructions thoroughly.

Proper tools will improve the quality of installation and reduce the time required.

To help prevent damage to the product or vehicle, refer to the specified torque specifications when securing hardware during the installation process.

Maintenance

To protect the product, wax after installing. Regular waxing is recommended to add a protective layer over the finish. Do not use any type of polish or wax that may contain abrasives that could damage the finish.

For polished, gloss and other smooth finishes, polish may be used to clear small scratches and scuffs on the finish.

Mild automotive detergent may be used to clean the product. Do not use dish detergent, abrasive cleaners, abrasive pads, wire brushes or other similar products that may damage the finish.

ASSEMBLY

Parts List

#	Qty	Description
1	1	Bumper guard
2	1	Driver / left tow hook bracket
3	1	Passenger / right tow hook bracket
4	1	Driver / left mounting bracket
5	1	Passenger / right mounting bracket
6	2	Adjustable mounting bracket
7	18	Hex bolt, M16
8	36	Flat washer, M16
9	18	Nylock nut, M16

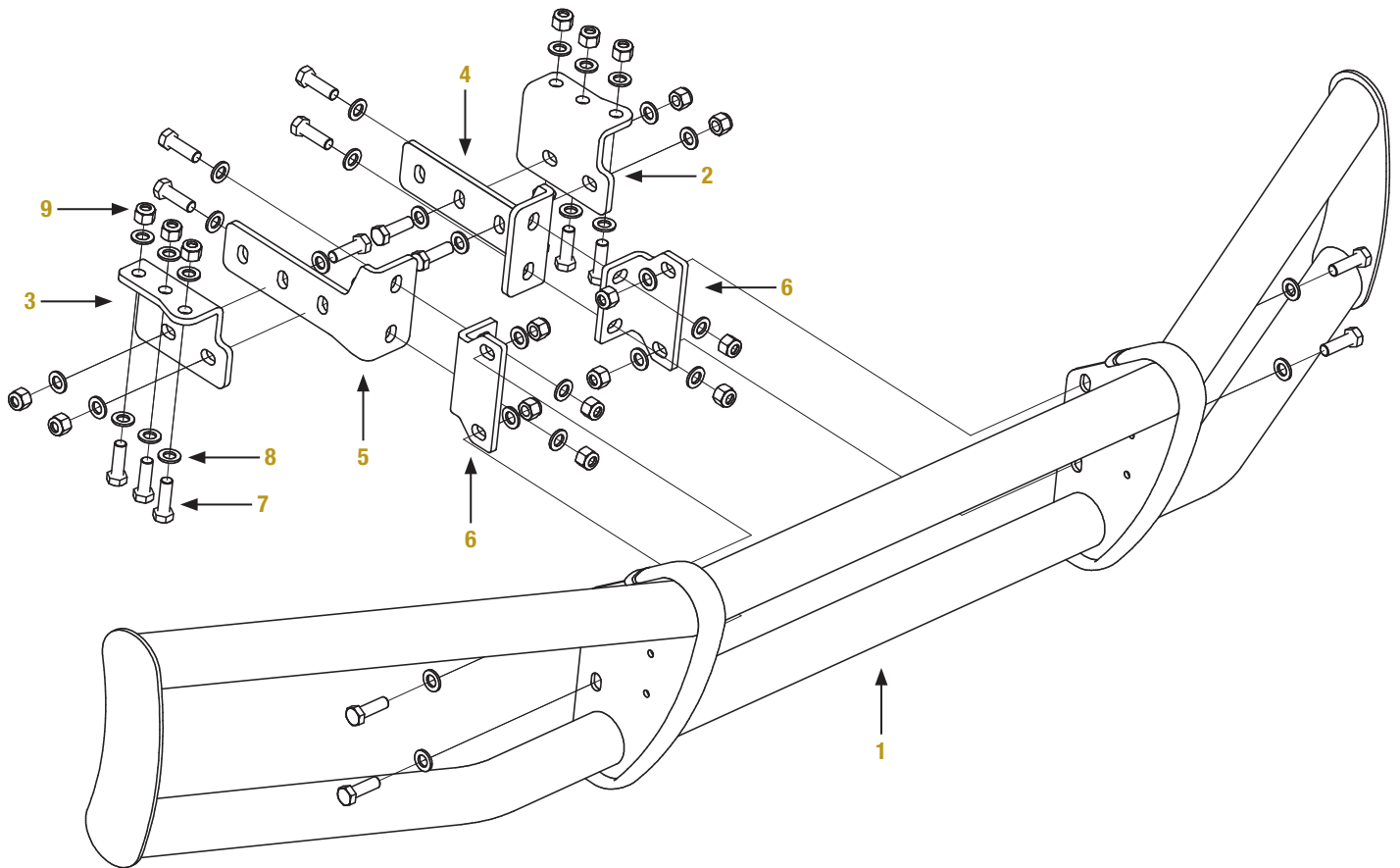

Step 1

Remove the front bumper by removing the four factory bolts with a 3/4" socket and wrench.

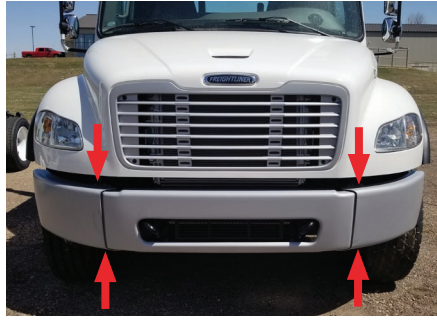

Step 2

Remove the factory tow hooks from the passenger and driver side using a 15/16" socket and wrench.



Step 3

Secure the passenger-side tow hook bracket (#3) to the frame using three M16 hex bolts (#7), six M16 flat washers (#8) and three M16 nylock nuts (#9).

Repeat on the driver side using the driver-side tow hook bracket.

Reinstall the front bumper.

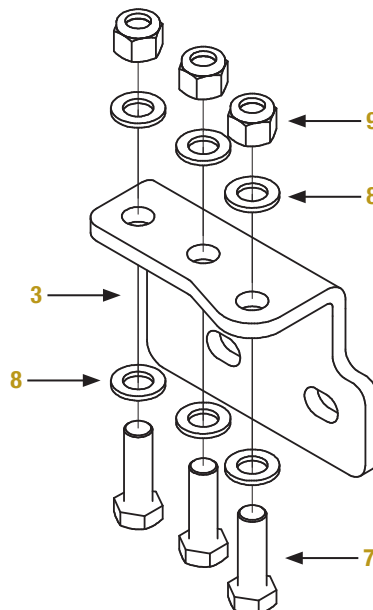

Step 4

Secure the mounting brackets (#4, #5) to the tow hook brackets (#2, #3) using two M16 bolts (#7), four M16 flat washers (#8) and two M16 nylock nuts (#9) on each side.

Snug the hardware, but do not fully tighten.

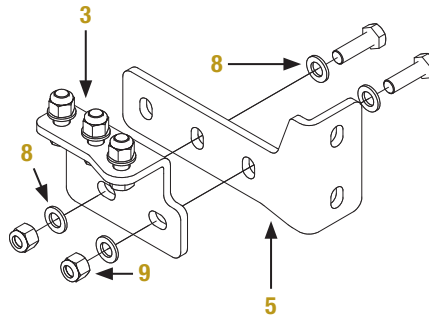

Step 5

Secure the adjustable mounting brackets (#6) to the mounting brackets (#4, #5) using two M16 bolts (#7), four M16 flat washers (#8) and two M16 nylock nuts (#9) on each side.

Snug the hardware, but do not fully tighten.

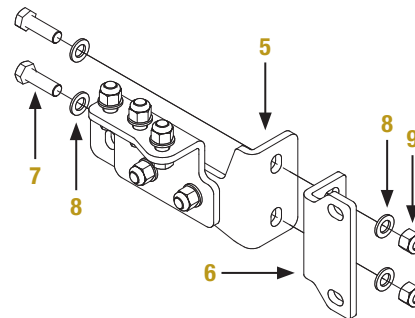

Step 6

Secure the bumper guard (#1) to the adjustable mounting brackets (#6) using two M16 bolts (#7), four M16 flat washers (#8) and two nylock nuts (#9) on each side.

Adjust the guard as needed to center on the truck. Tighten the remaining bolts to the torque specifications listed on page one.

NOTICE

The recommended guard location is as close to the truck as brackets allow and as high up as the brackets will allow without contacting the hood when open.

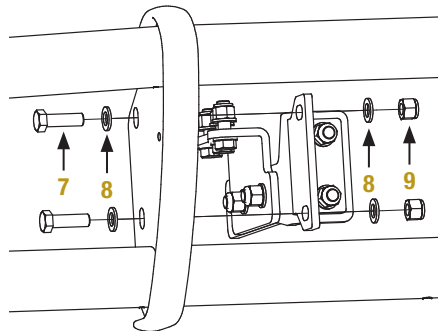

Step 7

Congratulations on the installation of your new RETRAC MileStone™ bumper guard.

With the bumper guard installed, periodic inspections should be performed to ensure all mounting hardware remains tight.

To protect your investment, see the 'Maintenance' section on the first page of this installation manual.



Representative photo, actual finish may vary