

Dual Intercooler Temp Gauge

DIGITAL DUAL INTERCOOLER TEMP GAUGE
DISPLAY RANGE :
50 ~ 300 °F

Part Number: 1TR1AA006R

1 Check and verify all included items:

- (1) 52mm Dual Intercooler Temp Gauge
- (1) Power Harness
- (2) Air Temperature sensors and wiring harness
- (1) Mounting Pod
- (1) Sun Shade (Hood)
- (1) 3M double sided tape
- (2) Mounting Bracket Threaded Extension
- (2) Washers
- (2) Nuts
- (1) Mounting Bracket

***NOTE**
Installation of the temperature sensors require 3/8 NPT weld-in bungs. These bungs are not included.

2 Make sure the car is turned off and disconnect the battery before attempting any electrical work.

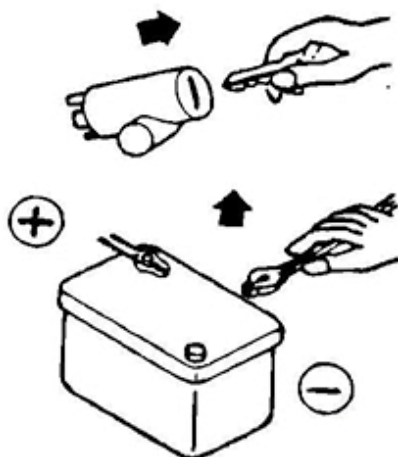

3 Optional mounting bracket:

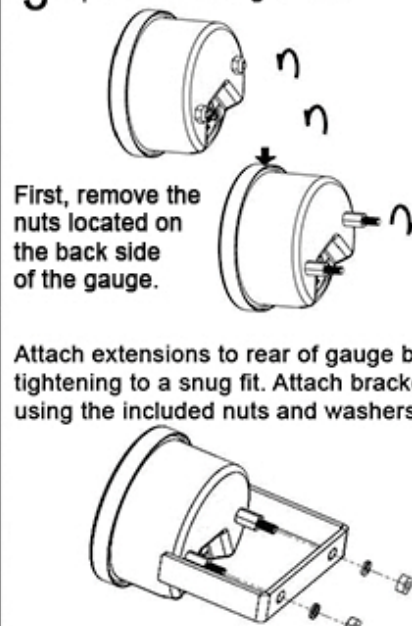

First, remove the nuts located on the back side of the gauge.

Attach extensions to rear of gauge by tightening to a snug fit. Attach bracket using the included nuts and washers.

4 Plug power wire harness to rear of gauge.

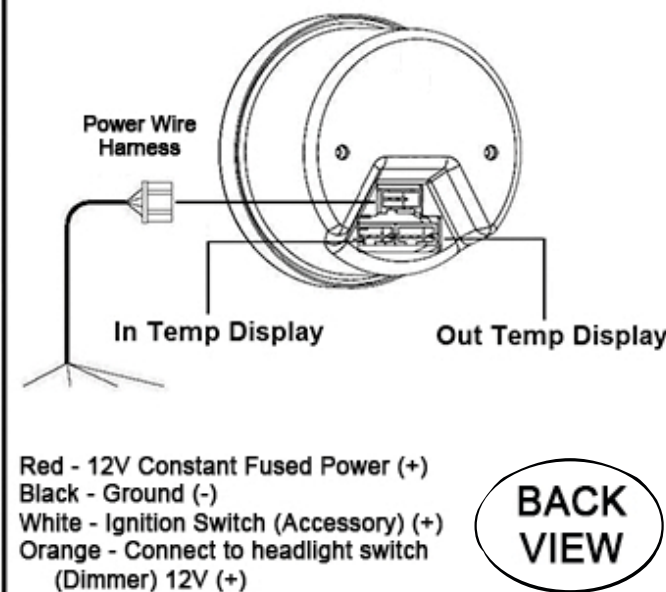

5 Air Intake Temp Sensor

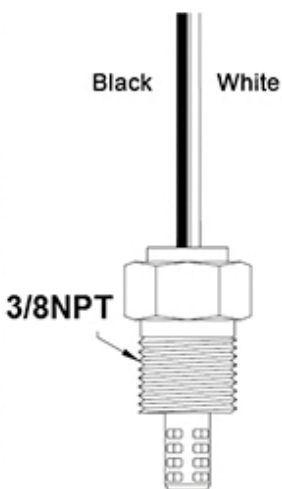

6 3/8 NPT weld-in bungs of the appropriate material are required to install the sensors onto the piping. *These bungs are not included.

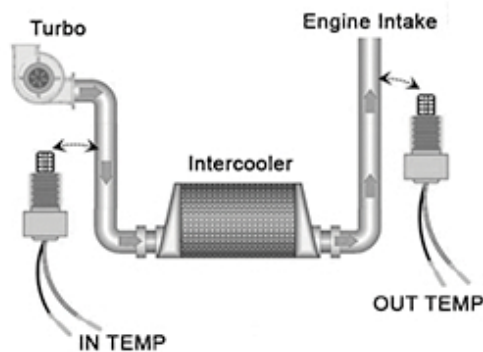

- The "IN TEMP" side sensor must be installed after the turbo and before the intercooler.
- The "OUT TEMP" side sensor must be installed after the intercooler and before the engine intake.

7 Plug harness sensors to rear of gauge.

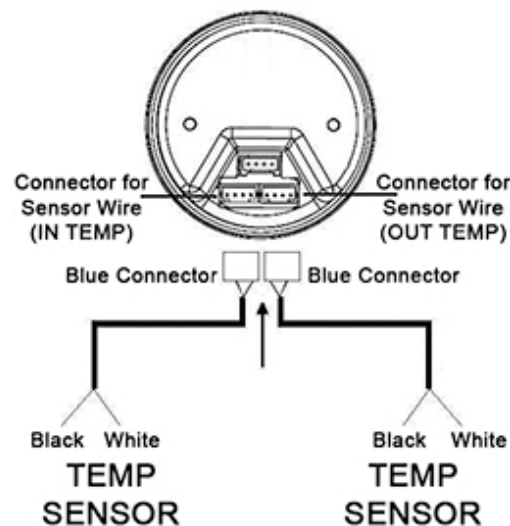

8 Reconnect the battery terminals.

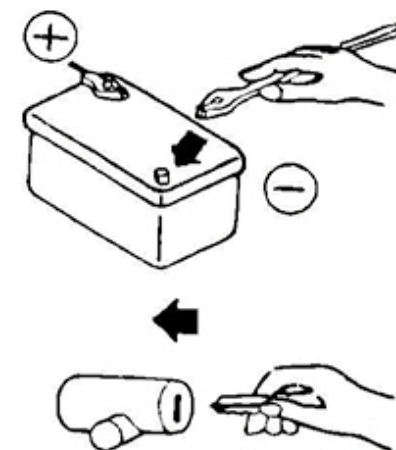

Voltage Gauge

DIGITAL VOLTAGE GAUGE
DISPLAY RANGE :
8 ~ 18 V

Part Number: 1TR1AA007R

1 Check and verify all included items:

- (1) 52mm Voltage Gauge
- (1) Power Harness
- (1) Daisy Chain Harness
- (1) Mounting Pod
- (1) Sun Shade (Hood)
- (1) 3M double sided tape
- (2) Mounting Bracket Threaded Extension
- (2) Washers
- (2) Nuts
- (1) Mounting Bracket

2 Make sure the car is turned off and disconnect the battery before attempting any electrical work.

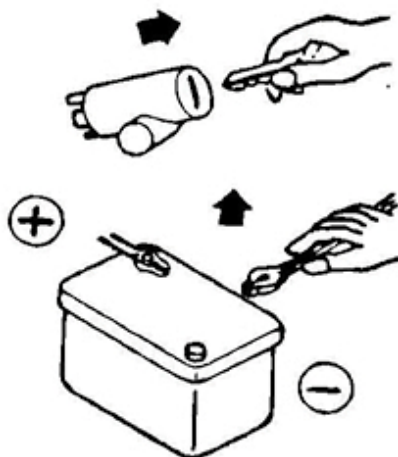

3 Optional mounting bracket:

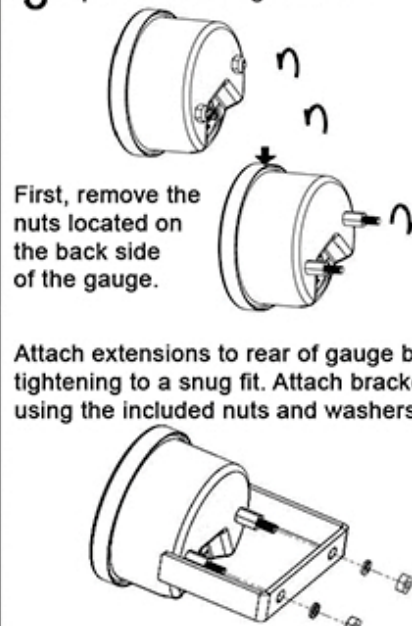

First, remove the nuts located on the back side of the gauge.

Attach extensions to rear of gauge by tightening to a snug fit. Attach bracket using the included nuts and washers.

4 Plug power wire harness to rear of gauge. Then reconnect the battery.

