





## DK410 Rhino-Rack VA, Euro & HD crossbar instruction

**Measurement A:** CENTRE of door jamb to CENTRE arrow of leg foot plate.

**Measurement B:** CENTRE of Front leg foot plate arrow to CENTRE of Rear leg foot plate arrow.

**Carrying capacity:** Roof rack is rated to 75kg. Please refer to manufacturers handbook for your vehicles maximum roof load capacity. Always use the lower of the two figures.

**Instruction below for Mazda 3 only.**

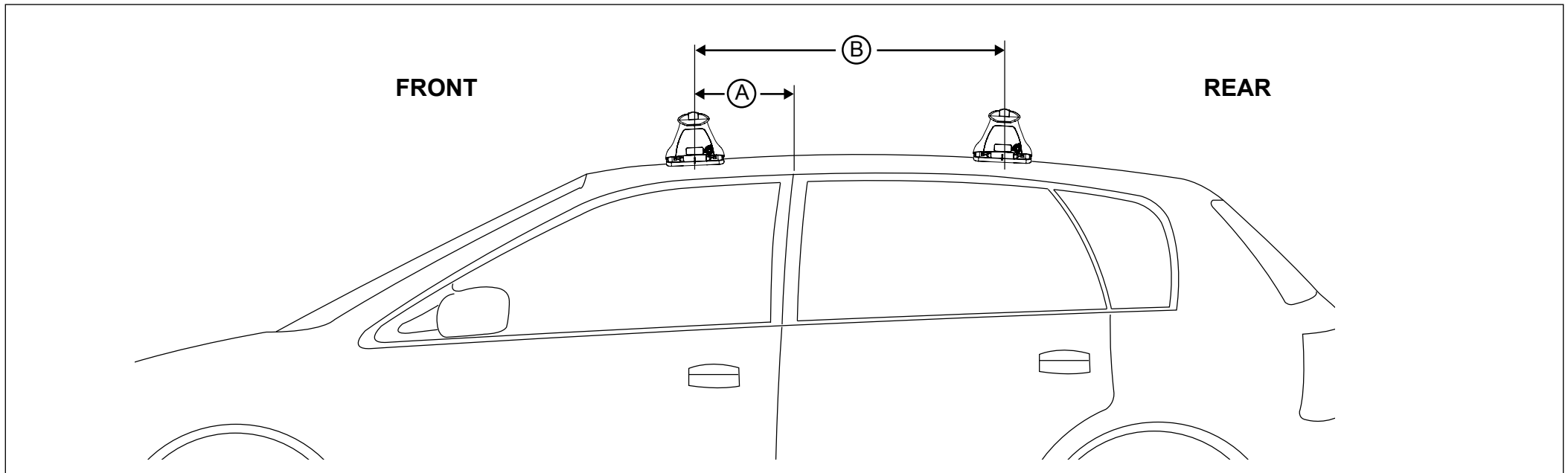

VEHICLE	Date	Measurement A	Measurement B	Load Rating (includes racks 5kg/ 11lbs)
Mazda 3 5dr Hatch (BM)	14 -	245mm / 9.6"	650mm / 26.5"	75kg/ 165lbs
Subaru Tribeca	06-14	N/A	N/A	75kg/ 165lbs

# DK410 Rhino-Rack VA, Euro & HD [crossbar](#) instruction

## Instruction below for Mazda 3 only.

**1** Move to the rear of the vehicle and locate the end of the gutter fill. Gently remove this gutter fill from the rear. The boot of the vehicle can be opened to allow greater access to the gutter fill.

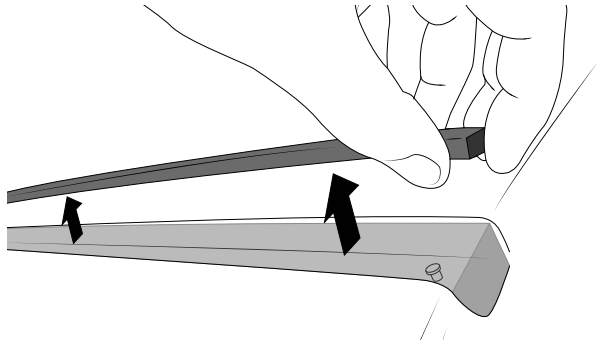

**2** Lay the gutter fill on the roof flush with the gutter itself as shown. Mark the center of the gutter fill in line with the mounting points found in the gutter.

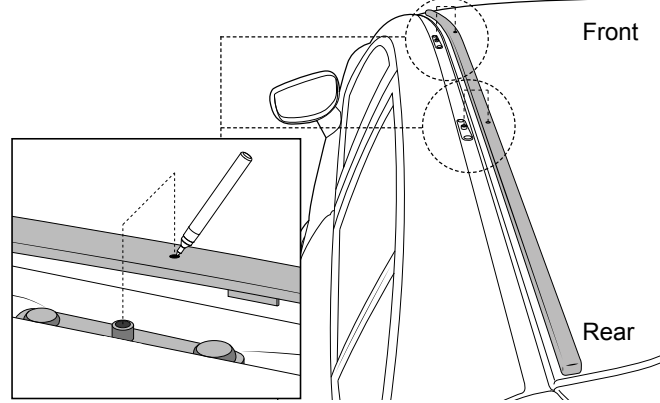

**3** With the gutter fill now marked, use a 9mm drill bit and carefully drill through the fill.

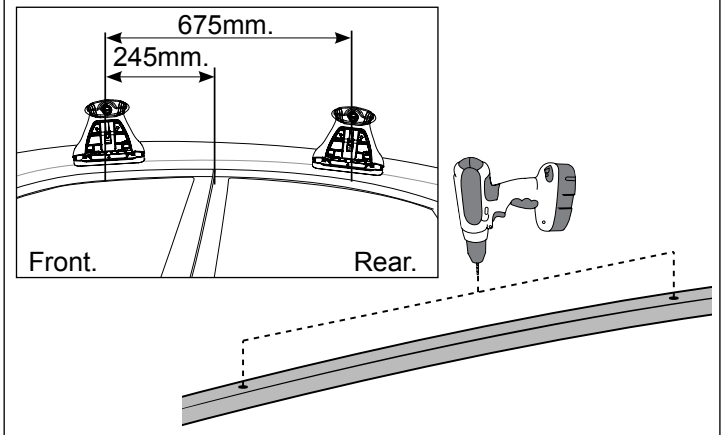

**4** Using Cold Galvanising Paint, seal the newly drilled holes in the gutter fill.

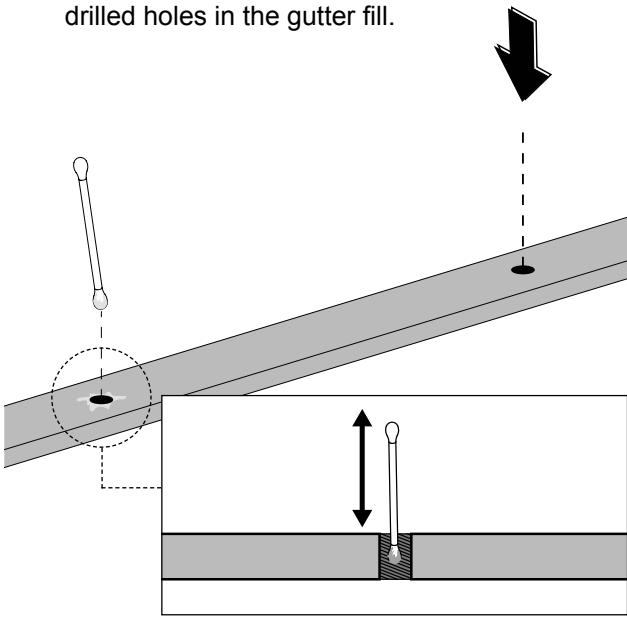

**5** Place the gutter track back into the roof. Repeat previous steps for the opposing side of the vehicle.

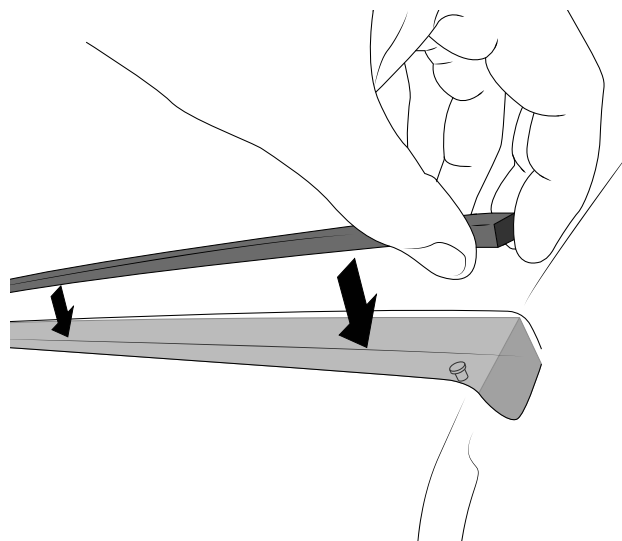

**6** Insert the leg studs into holes in the gutter fill, finger tighten.

