



RHINO-RACK

FORD RANGER PX/MAZDA BT50 GEN 2 - RTS554

Important:

1. Check the Rhino-Rack website to ensure you have the latest issue of these instructions.
2. Please refer to your fitting instruction to ensure that the roof racks are installed in the correct locations.
3. Check the contents of kit before commencing fitment and report any discrepancies.
4. Place these instructions in the vehicle's glove box after installation is complete.
5. These instructions must be followed for warranty to be upheld.

Fit Time: 120min

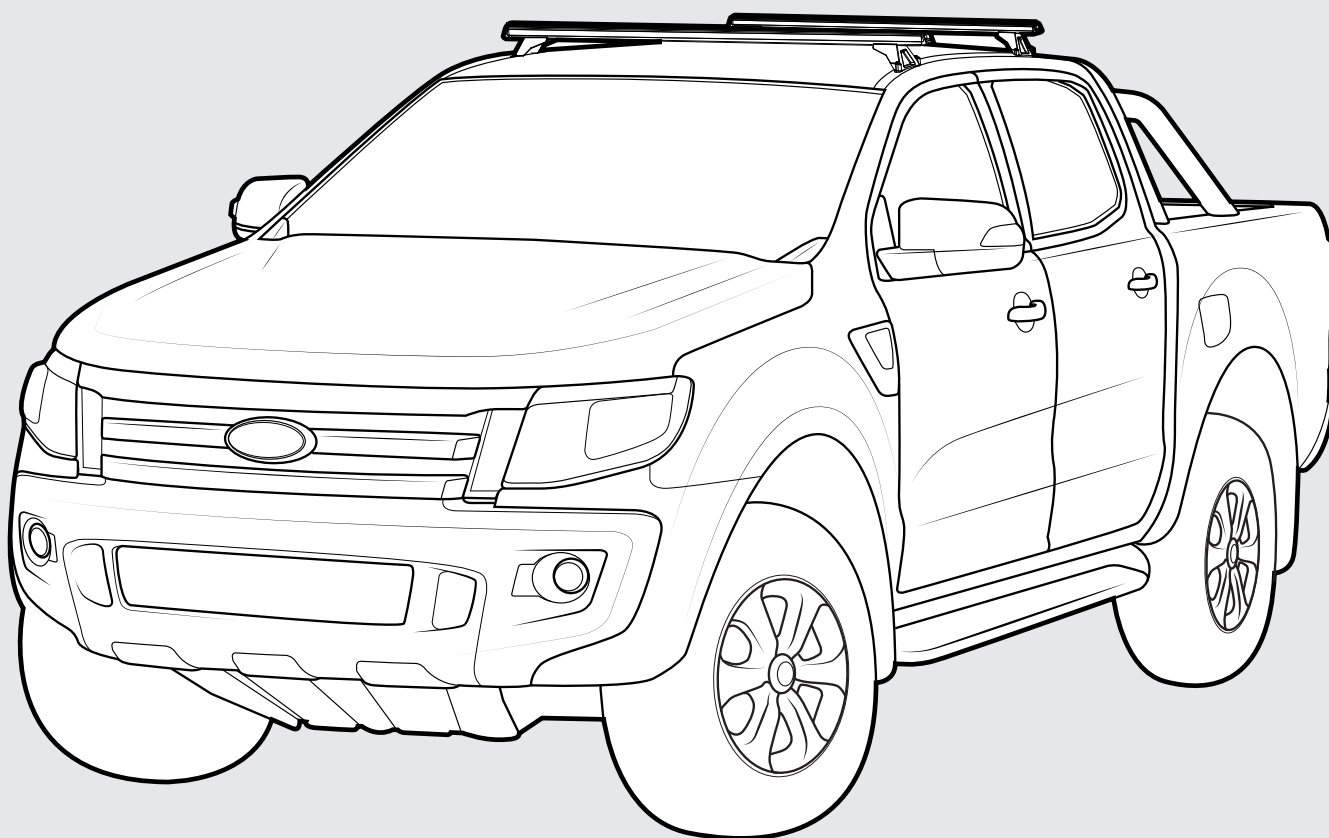

FORD RANGER SHOWN
ALSO COMPATIBLE WITH
MAZDA BT50 GEN2

RTS554 Instructions

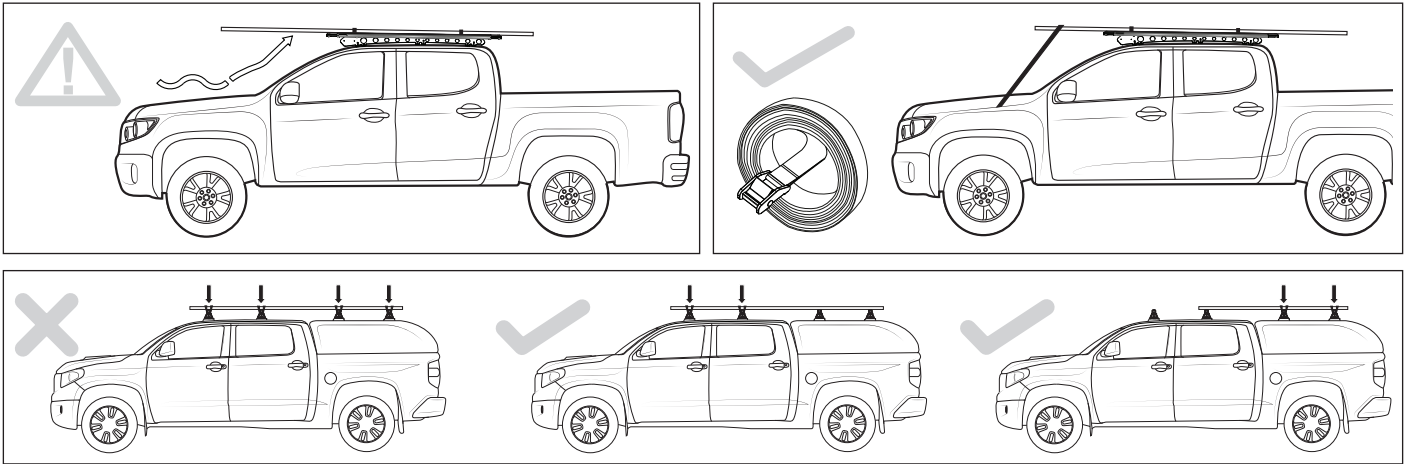

System Load Limit	Off Road Load Allowance	Vehicle Load Limit	Two Cross bar Weight
95kg / 209lbs	63kg / 138lbs	100kg / 220lbs	5kg / 11lbs

Carrying Capacity

Check your vehicle owners hand book for vehicle maximum carrying capacity. Please ensure you use the vehicle manufactures maximum roof allowance if it is lower than the figure listed in this instruction.

Load must be evenly distributed over the system.

Off Road: Any driven path taken that does not contain a surface protection layer (tar/bitumen).

Vehicle Load Limit: Total permissible weight attached to the roof of the car. This is inclusive of the weight of the roof rack system.

System Load Limit: Total permissible weight allowed on top, and attached to roof racks whilst the vehicle is in motion.

Torque Settings

Unless stated otherwise in these instructions, all fasteners should be set to the following torque settings - M6: 4-5Nm (3-4lbs/ft), M8: 8-10Nm (6-7.5lbs/ft) and M10: 16-18Nm (12-13lbs/ft).

Warning

- Check part number/ or kit is correct for use with your vehicle.
- Do not attempt to fit the rack system to your vehicle unless you fully understand these fitting instructions. Please direct any questions regarding fitting to the dealer from where the roof racks were purchased.
- Although the system is tested and approved to AS1235-2000 / ISO 11154, off-road conditions can be much more rigorous. Extreme care must be taken in off road conditions.
- Roof racks must be removed when vehicle is put through an automatic car wash.
- With utility vehicles, the cabin and the canopy move independently. Roofracks and vehicle can be damaged if the item transported is rigidly fixed at points on both the cabin and canopy. Instead, rigidly fix to either the cabin roof racks or the canopy roof racks.
- Always ensure you fasten your load securely.
- Use only non-stretch fastening ropes or straps to attach cargo to your load.
- Clean and dry vehicle/ rails before fitting roof rack.

In service maintenance checks

- All bolt connections should be checked after driving a short distance when you first install your roof racks.
- All bolted connections should be checked again at regular intervals (weekly is recommended, depending on road conditions, usage, loads and distances travelled).
- All bolted connections should be checked each time they are re-fitted.

Note for Dealers and Fitters

It is your responsibility to ensure these fitting instructions are given to the end user or client. These instructions remain the property of Rhino-Rack Australia Pty. Ltd. and may not be used or changed for any other purpose than intended.

Parts list

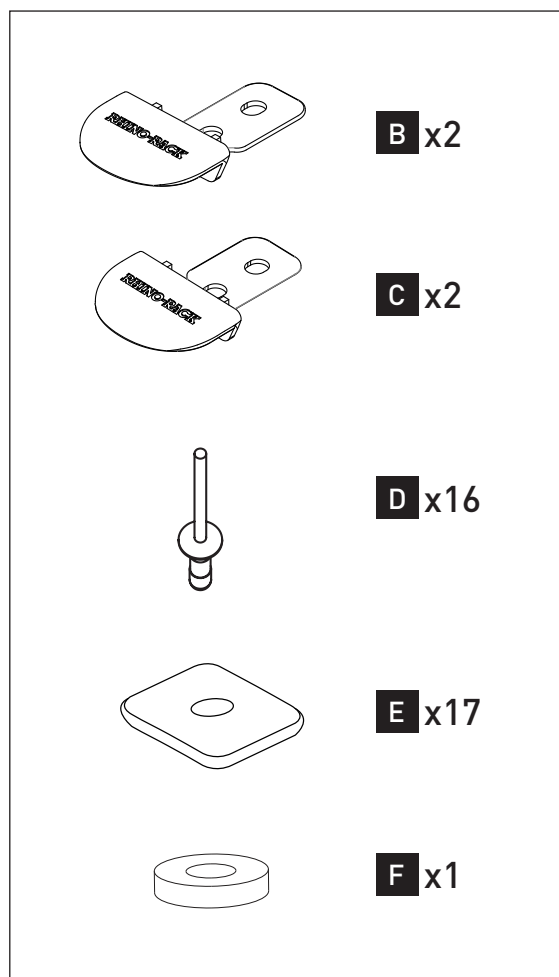
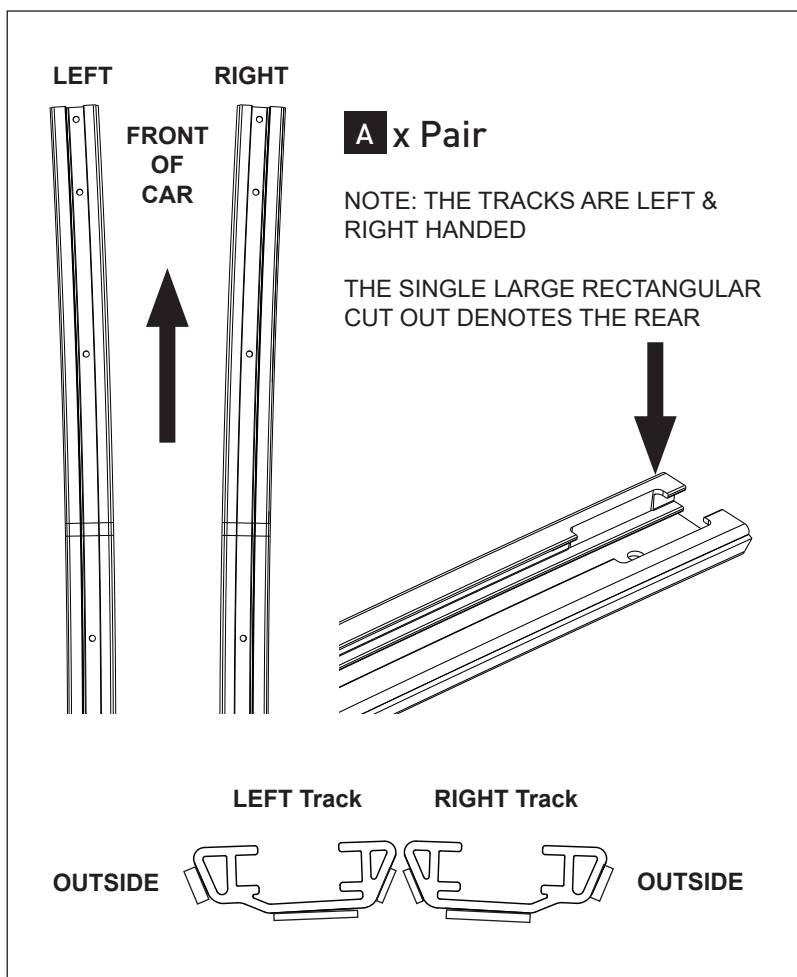

Item	Description	Qty
A	Track (left and right)	1
B	End Cap FL RR	2
C	End Cap FR RL	2
D	Stavex Rivet BS 11 4.8mm	16
E	Butyl Patch	17
F	Rivet Spacer	1
G	Instructions	1

-Tools Required:

-Herramientas necesarias:

- T1 - Pneumatic Rivet Gun
- T2 - Masking Tape
- T3 - Rubber Mallet
- T4 - Flat blade screwdriver
- T5 - Power Drill
- T6 - 5mm drill bit
- T7 - Drill stop
- T8 - Cold galvanising paint and cotton buds
- T9 - Knife (AUS/NZ) or
 - Dremmel with cutting blade (USA)
- T10 - Vacuum
- T11 - Marker
- T12 - 3mm drill bit

Note:

- Assistance is required to fit the system.
- Se requiere asistencia para adaptarse al sistema.

IMPORTANT Care Instruction:

- Wash the vehicle prior to fitting the system, especially the area the track will be mounting to.
- lavar el vehículo antes de instalar el sistema.

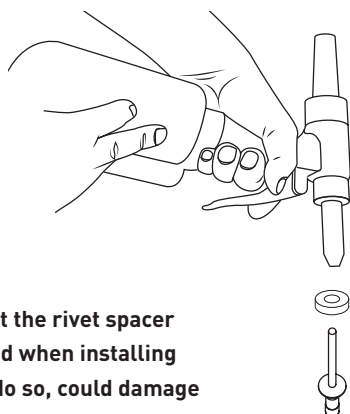

IMPORTANT Note:

It is important that the rivet spacer (item **F**) is used when installing rivets. Failure to do so, could damage the track or the rivet may not seat correctly.

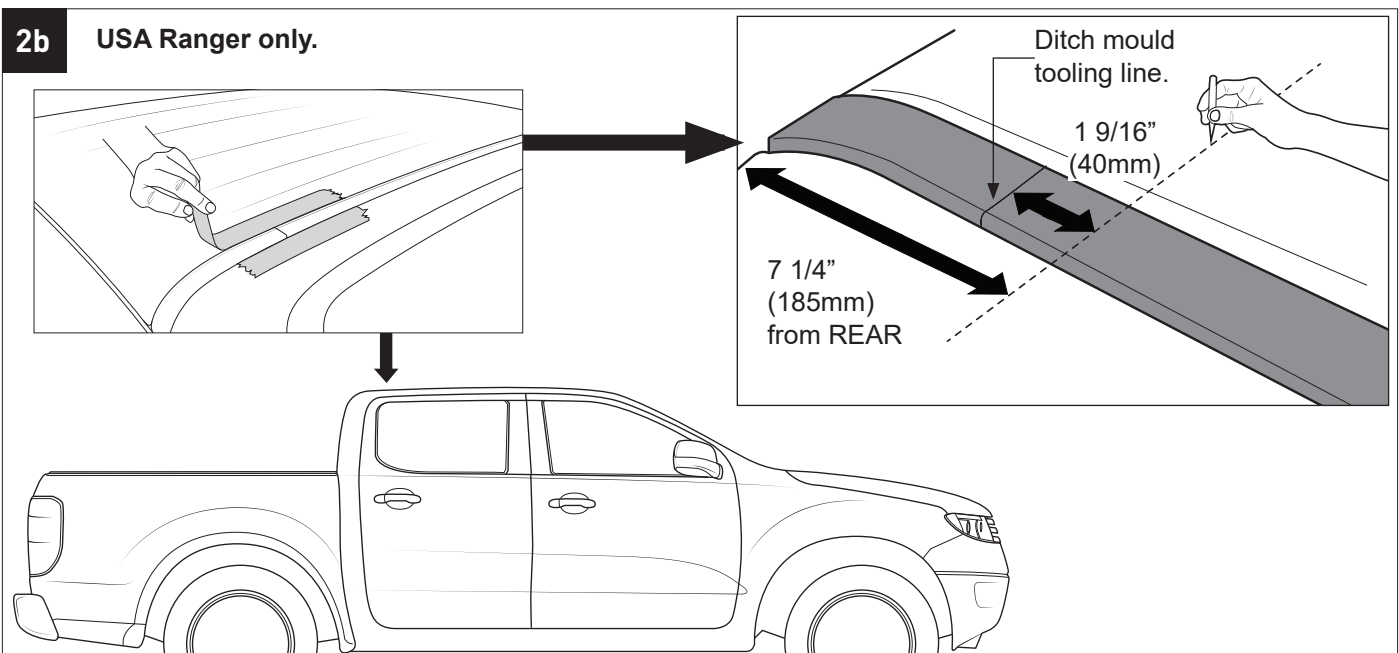
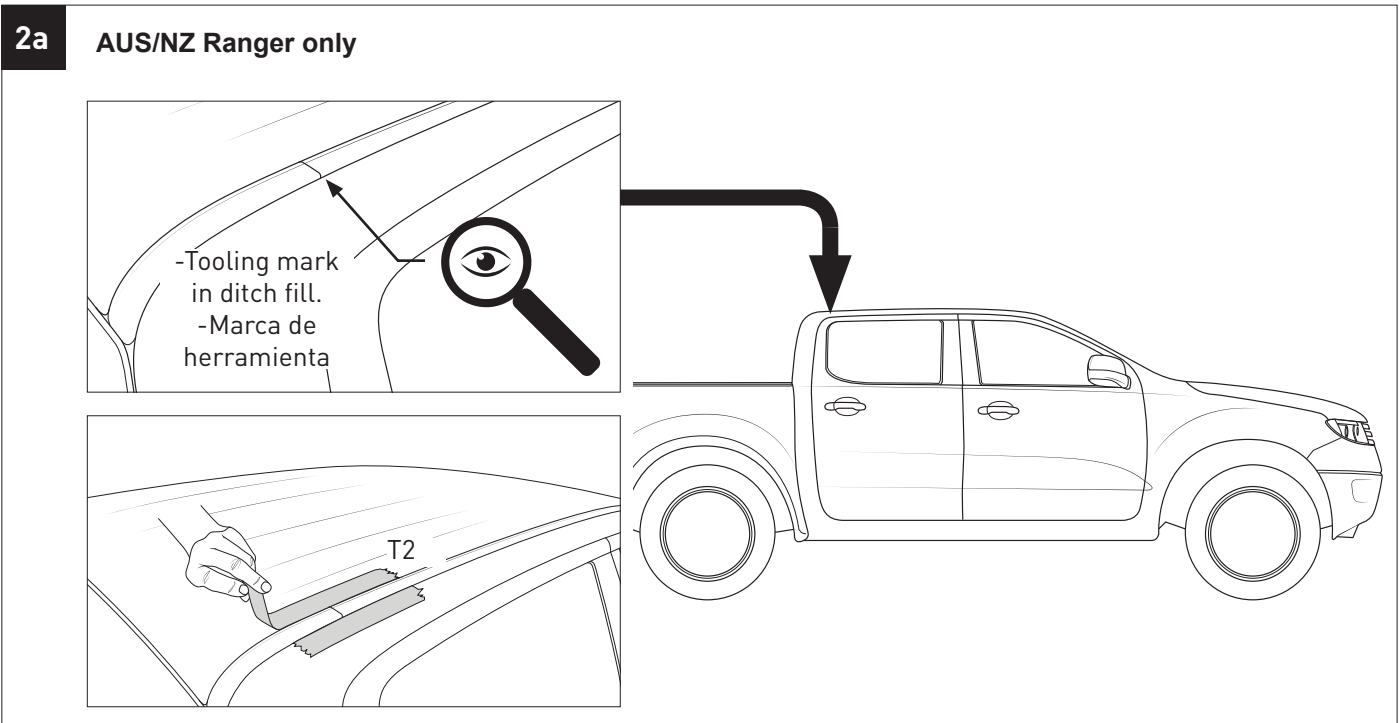
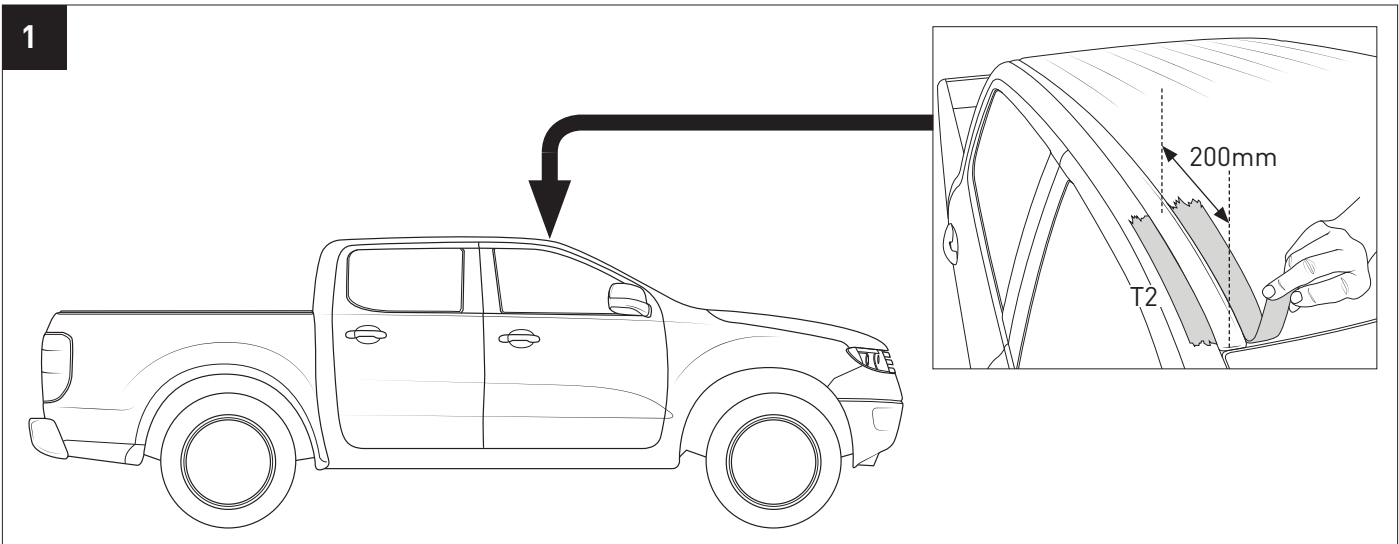

3

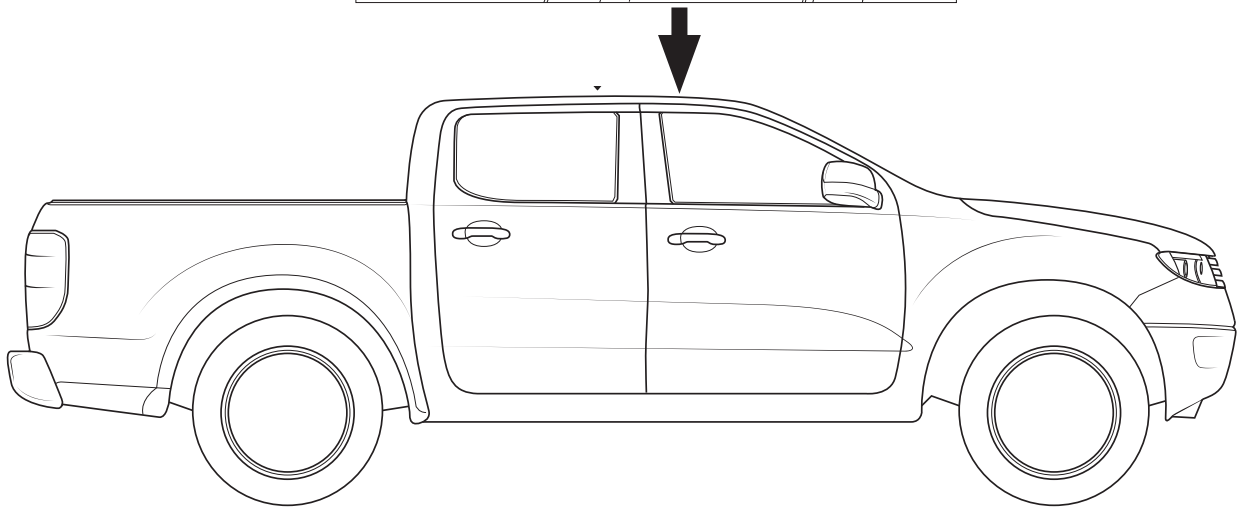
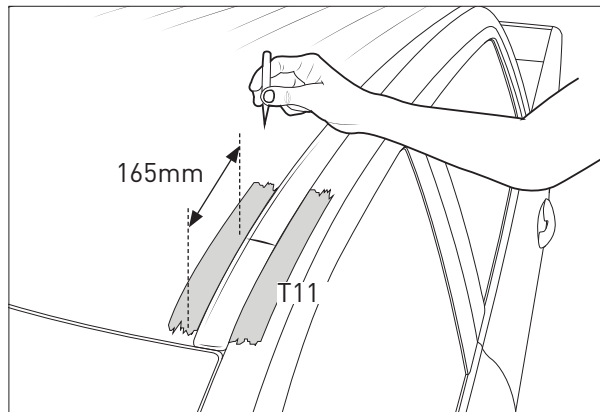

4a AUS/NZ Ranger

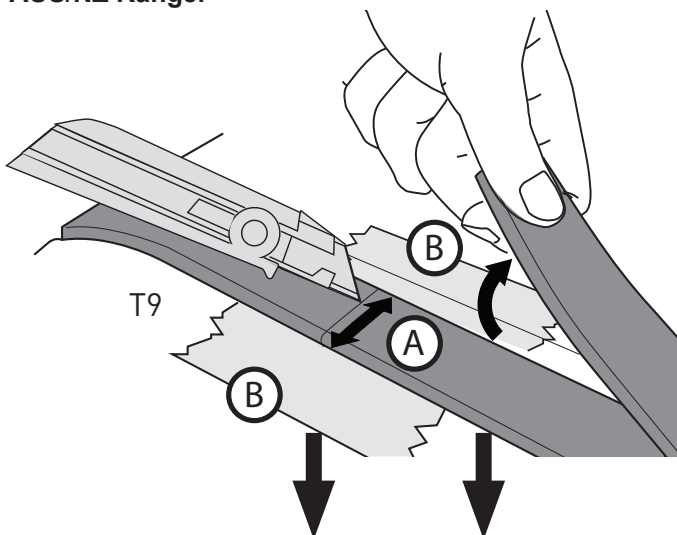

A. Slice the trim exactly on the line in the moulding location marked in steps 2a & 3.



Work back & forth to snap the stainless steel core in the rubber trim

B. Make sure you apply protection on both sides of the track to prevent the knife from slipping and marking the roof.

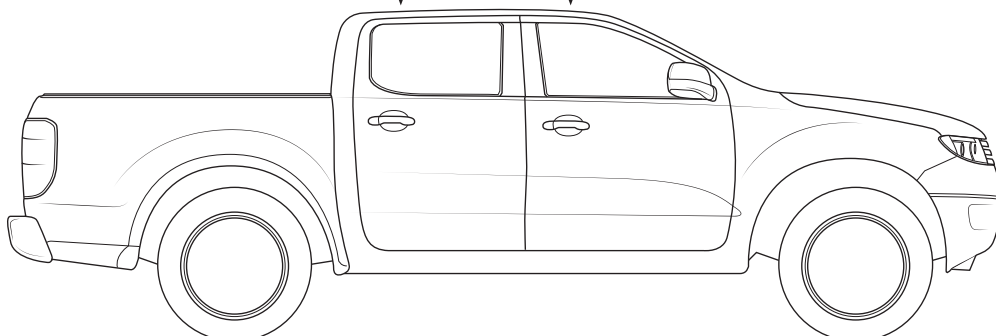

4b USA Ranger only.

A. Carefully cut the trim exactly on the lines marked in steps 2b & 3.

B. Make sure you apply protection on both sides of the track to prevent the knife from slipping & marking the roof.

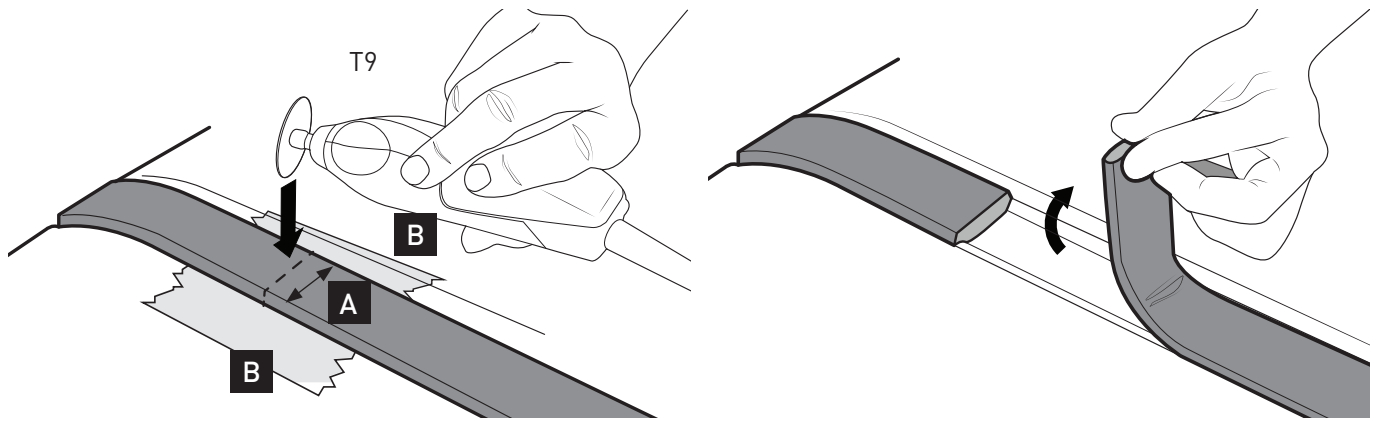

5

Rubber strip
Tira de goma

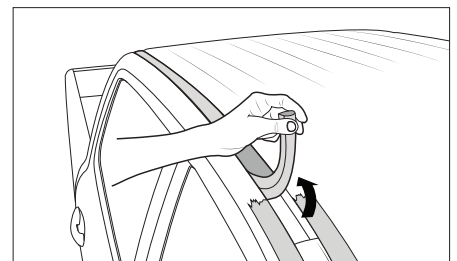
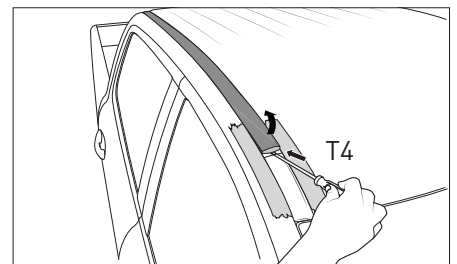
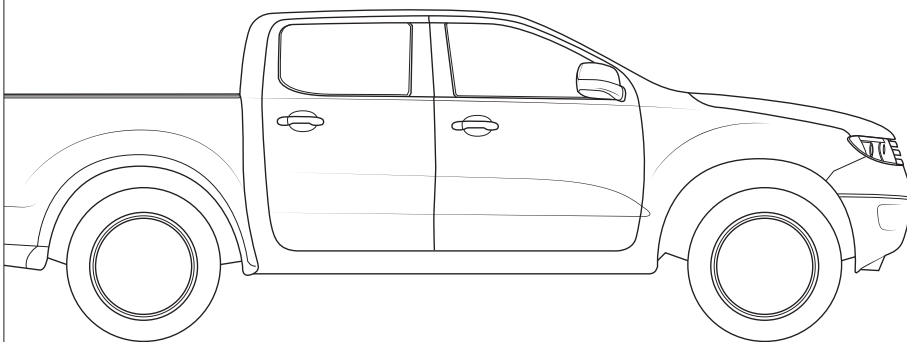

6 **B** **C** FRONT

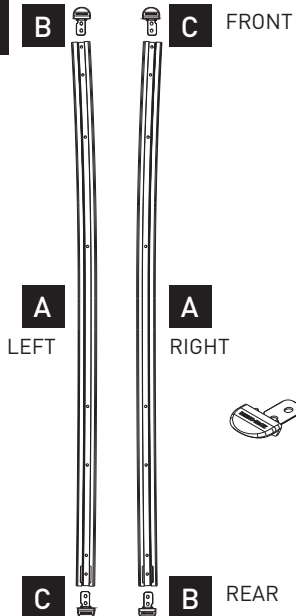

7

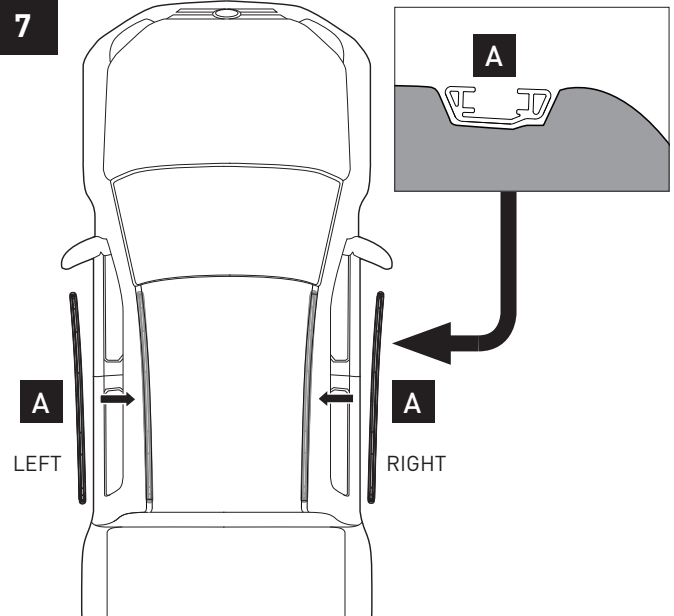

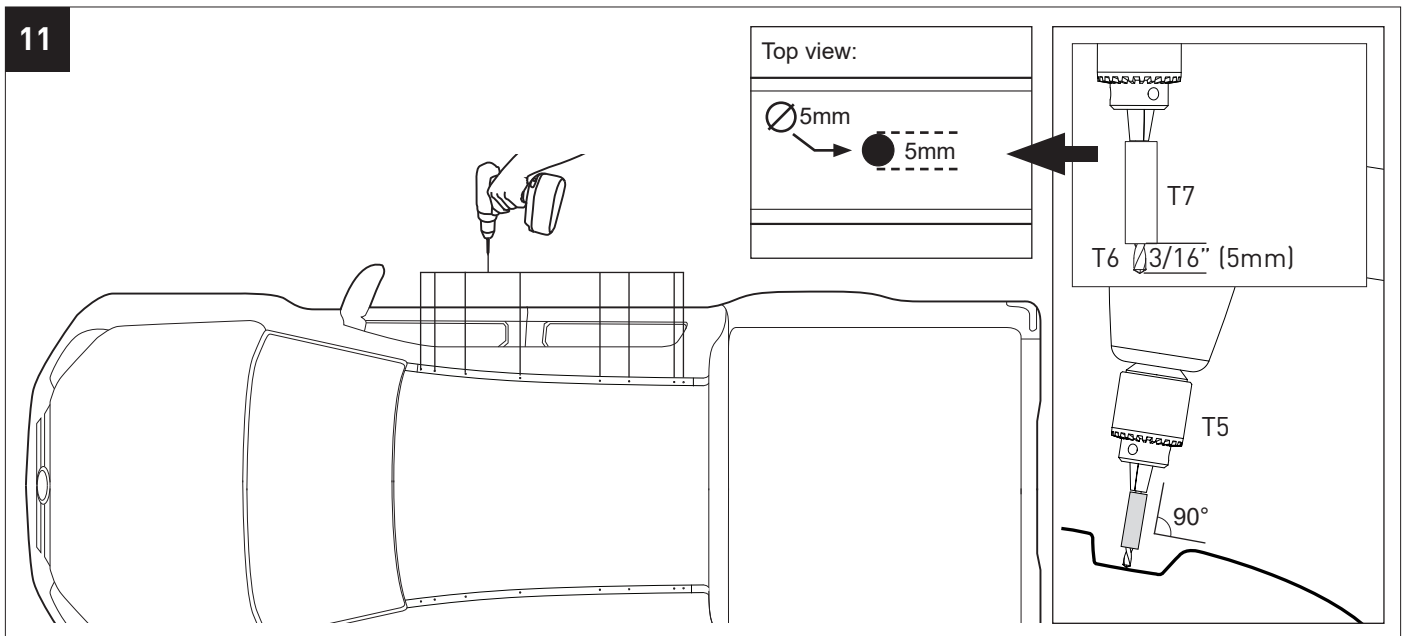
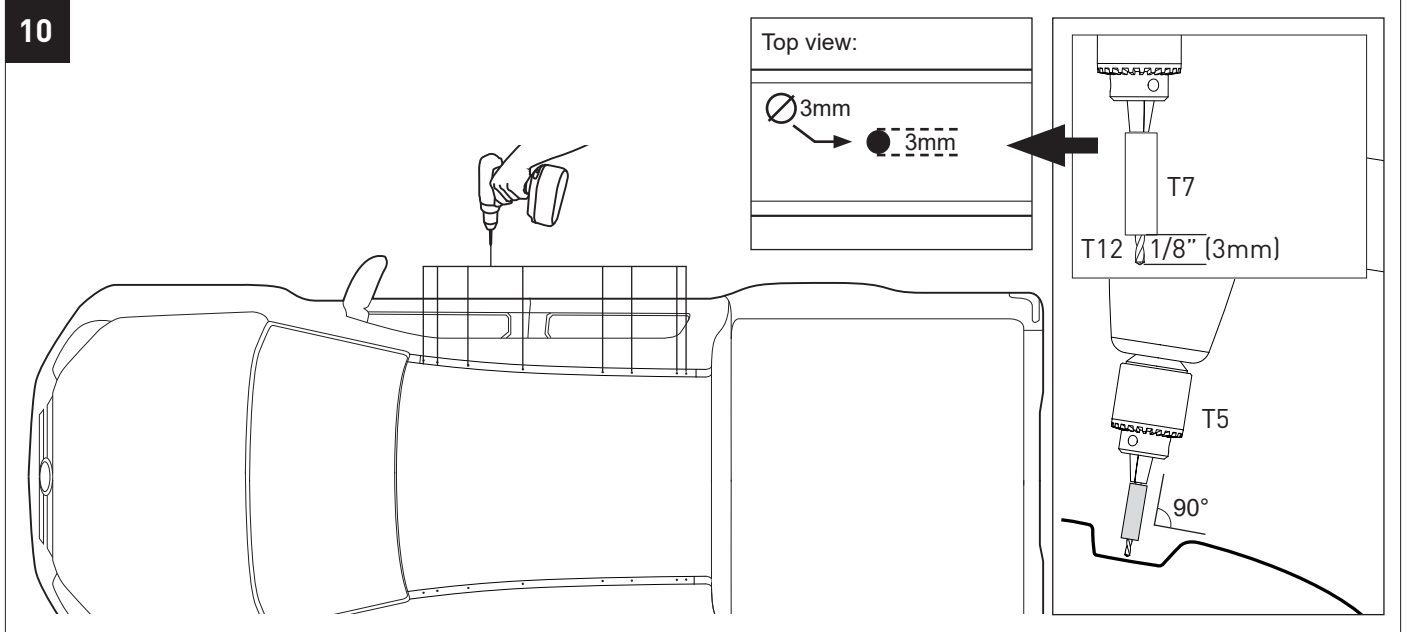
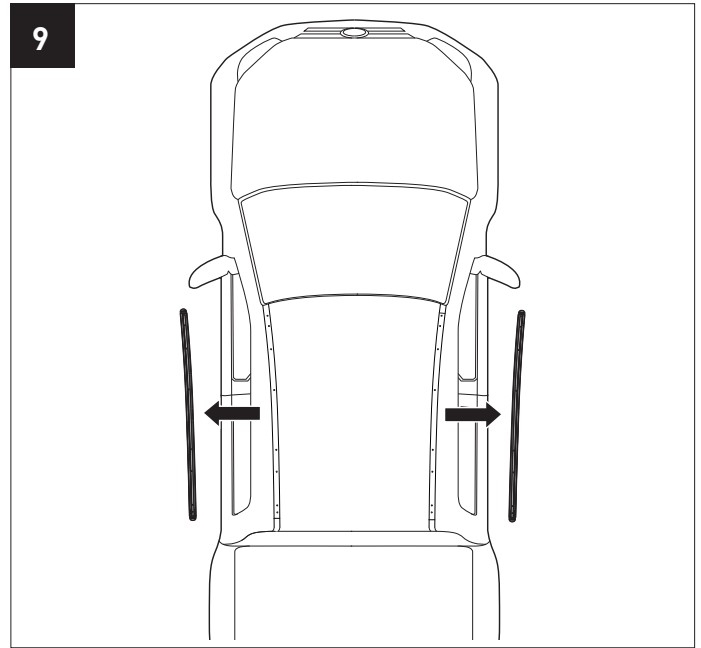
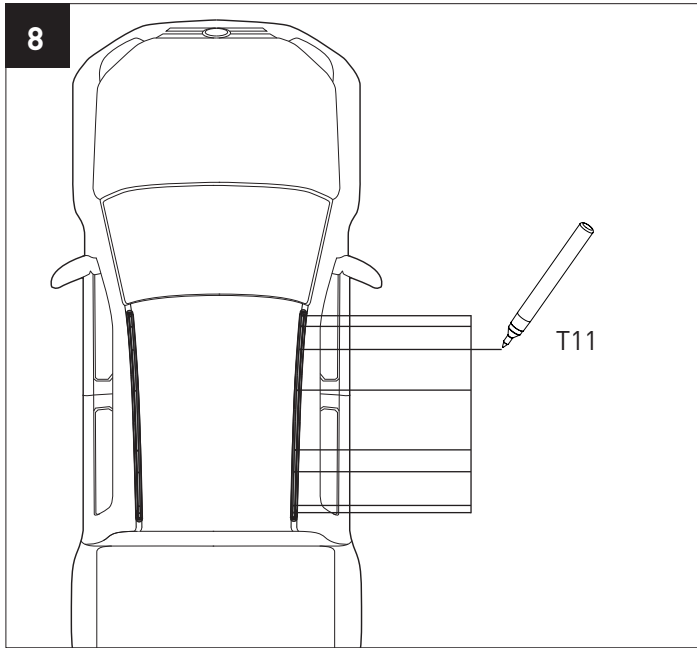

12

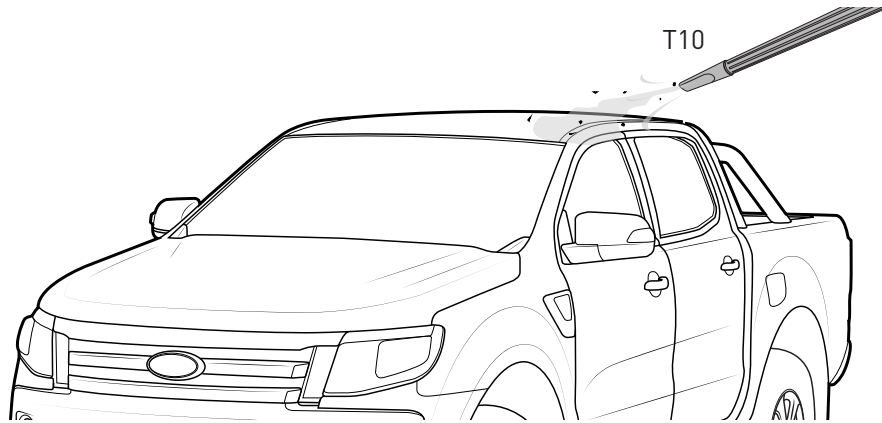

13

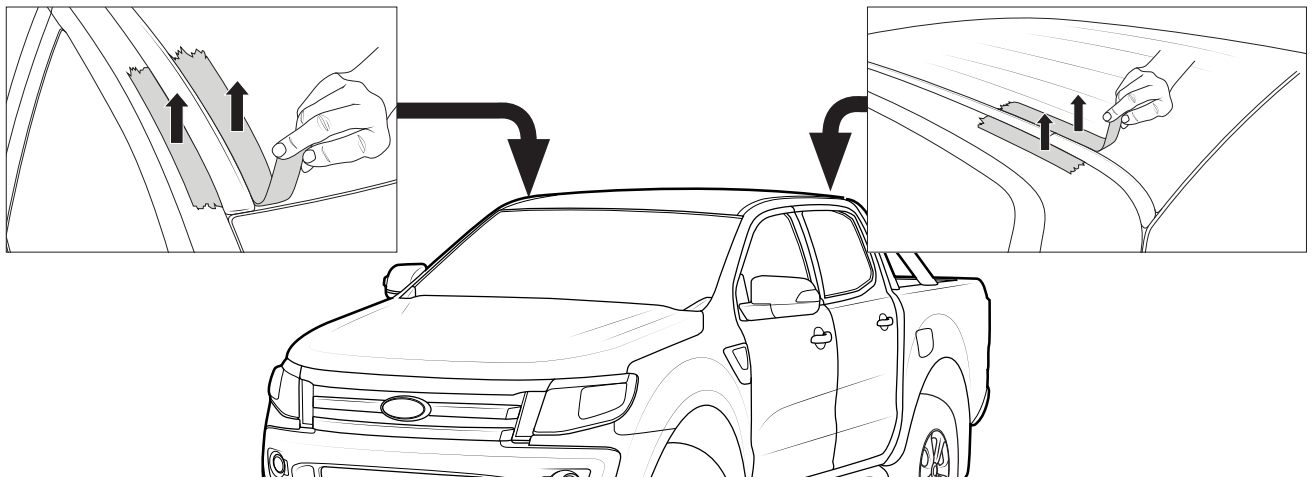

14

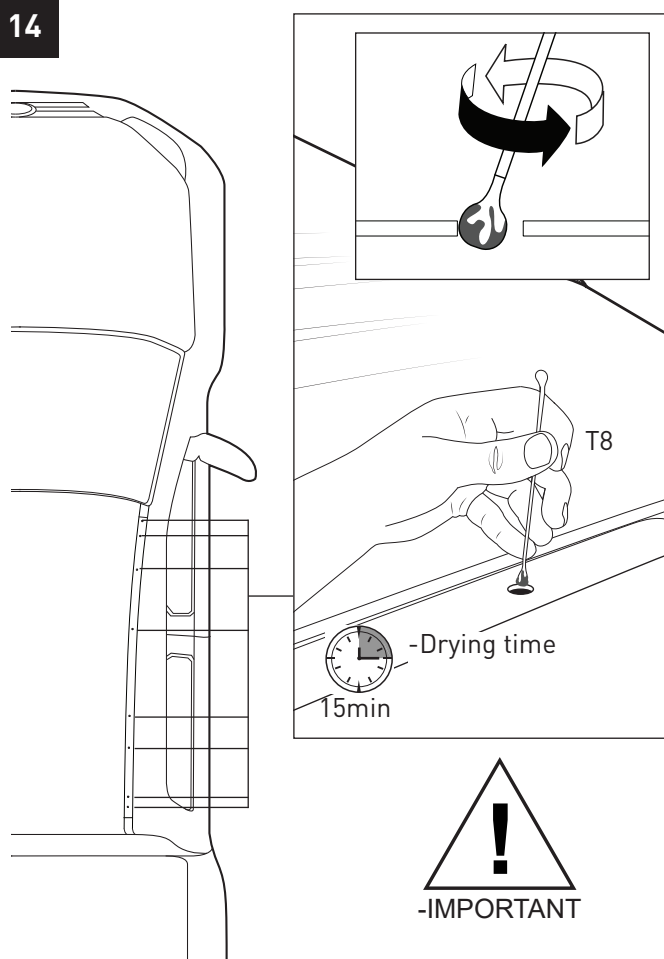

15

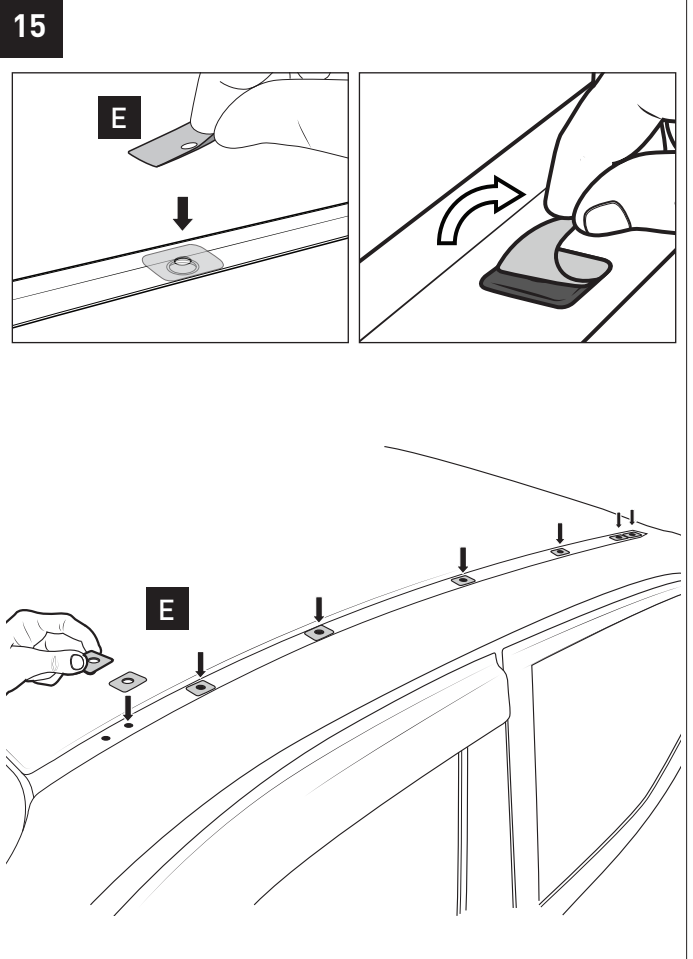

15

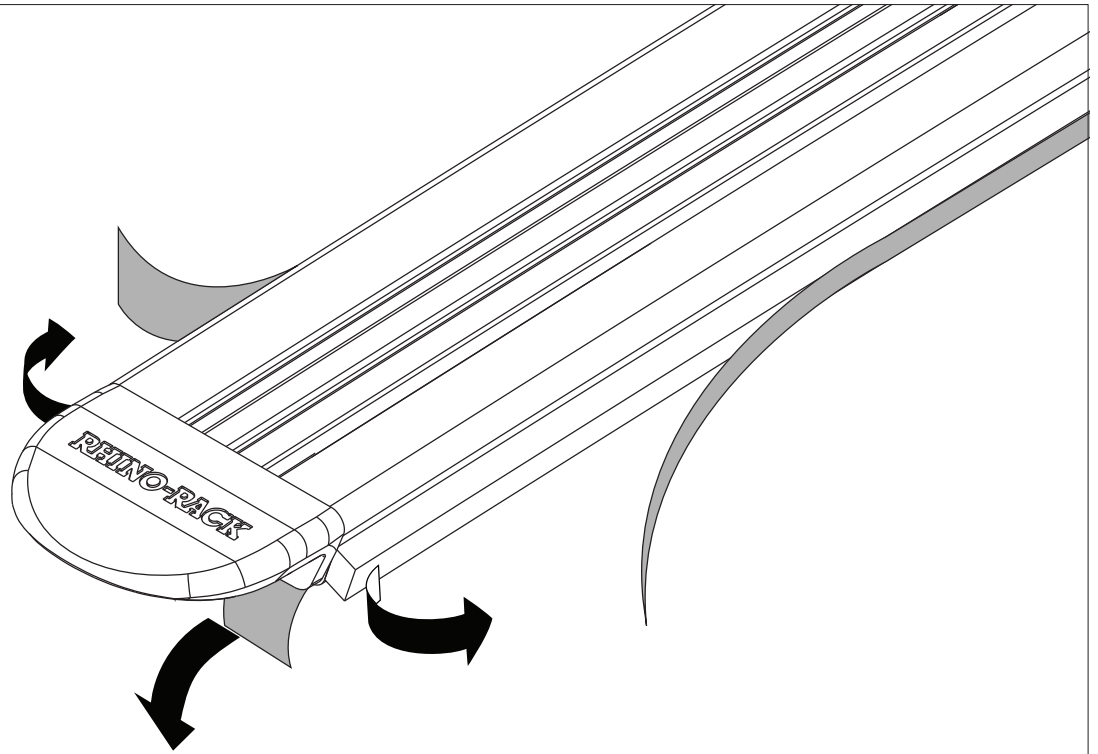

16

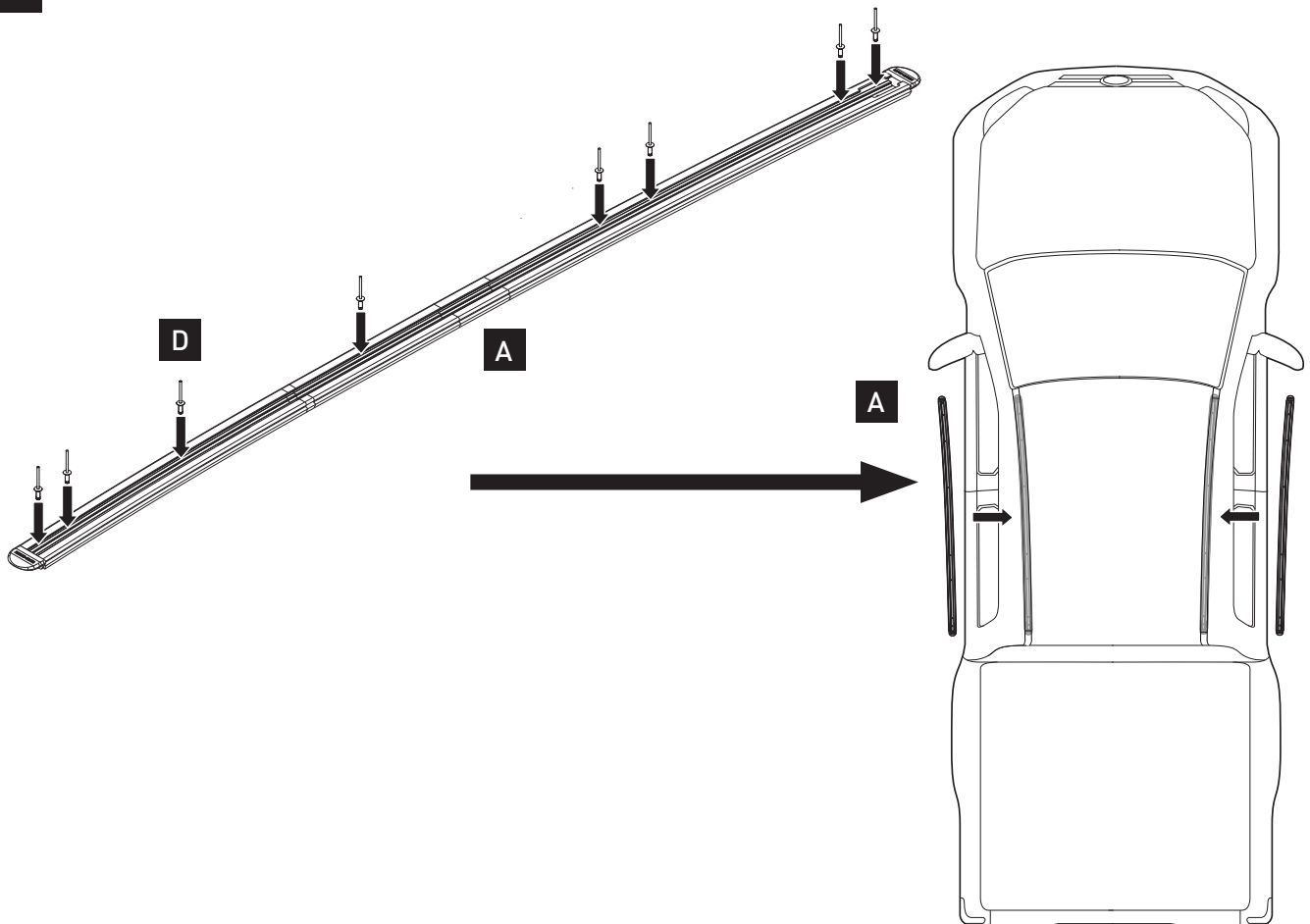

17a

Ensure rivets are seated correctly

DO NOT STRIKE THE RIVET STEM WITH ANY TOOLS AS IT MAY PREVENT IT FASTENING CORRECTLY

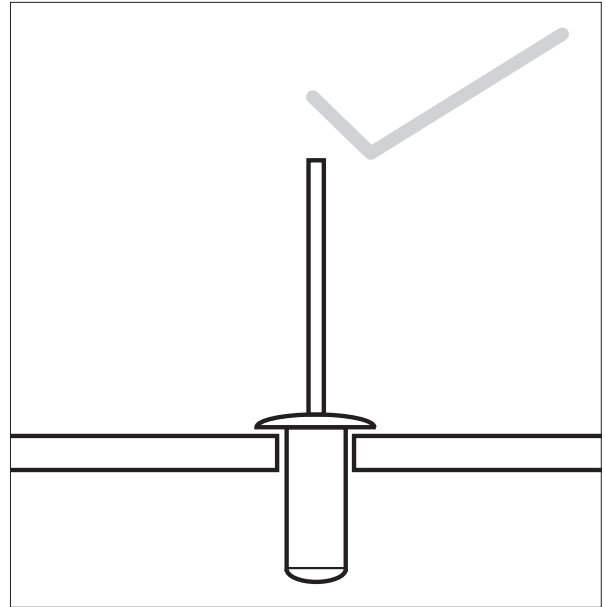
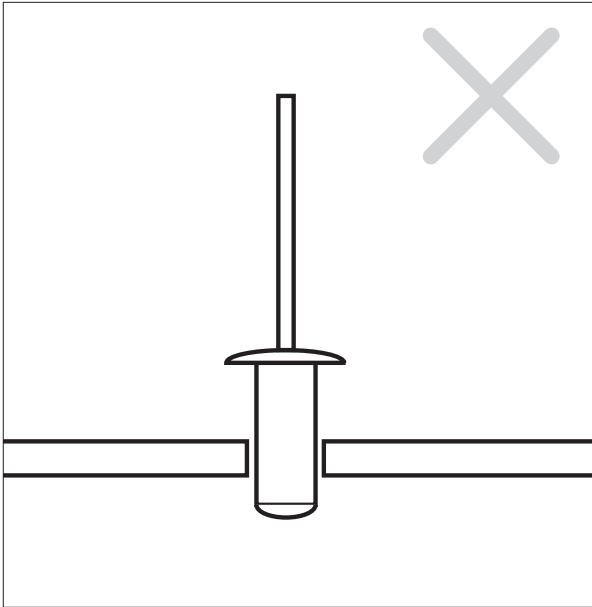

17b

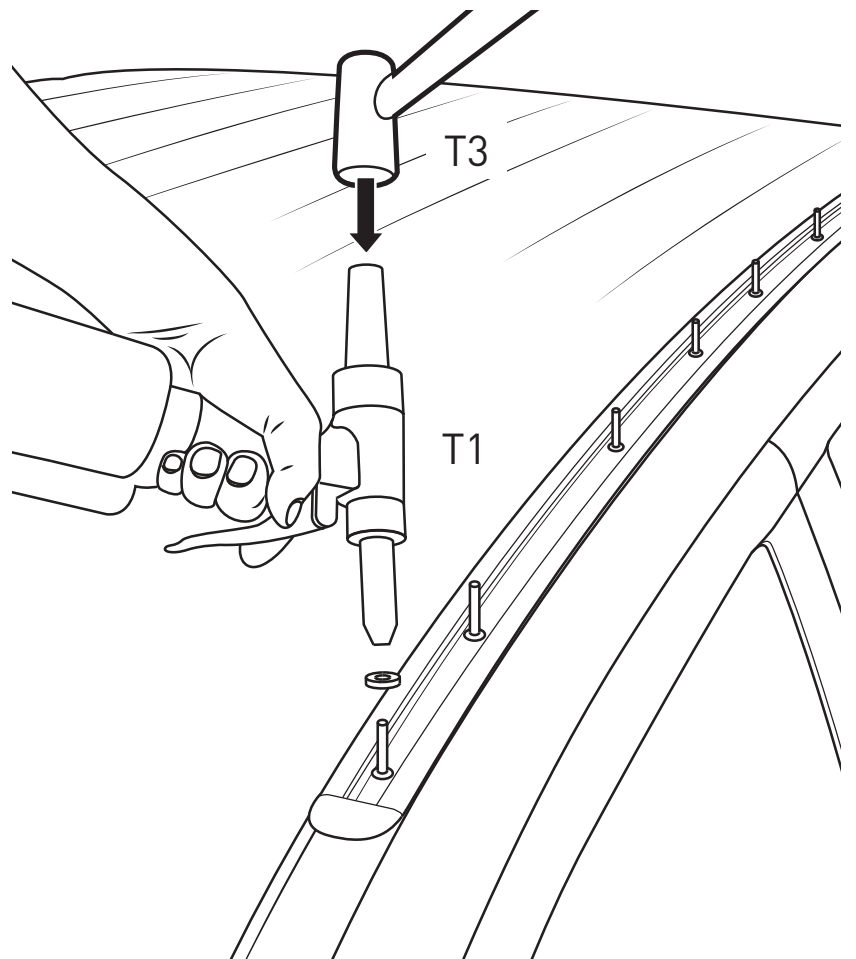
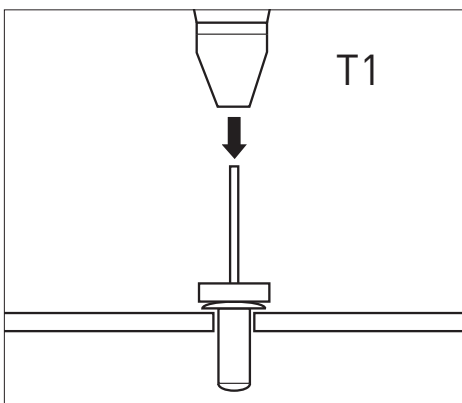
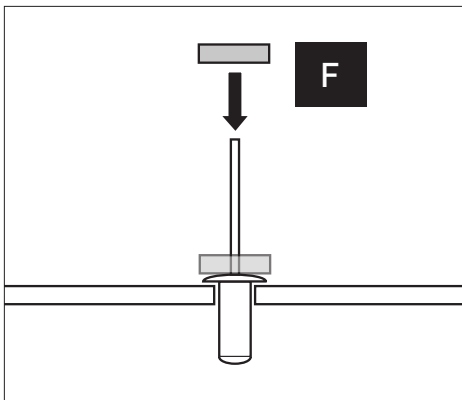

18

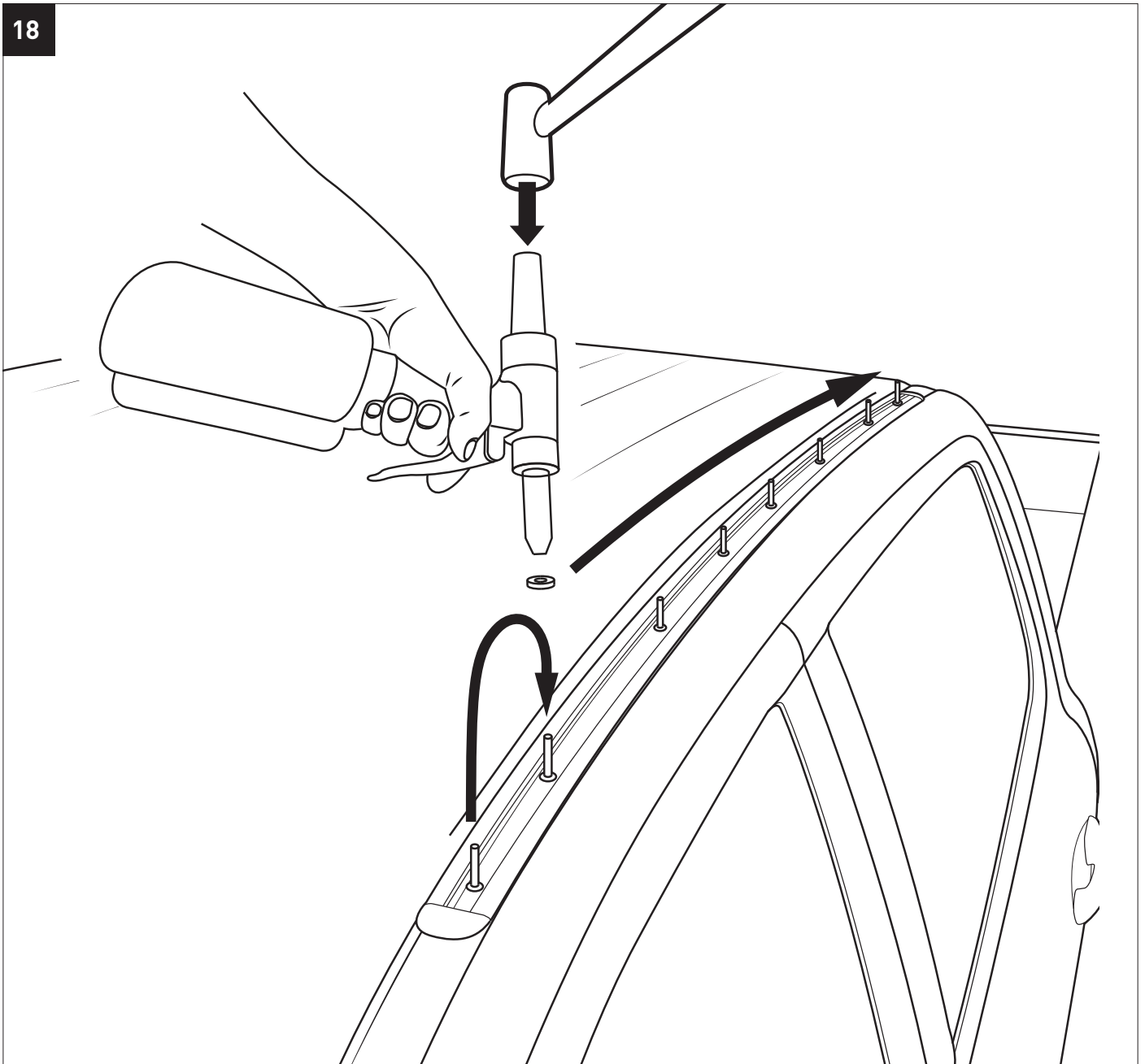

NOTE:

If fitting a backbone refer to the latest issue of the backbone instruction on the website & use the following backbone measurement

