



RHINO-RACK

RVL, RVH 2,4,6 Kits

Important: Please read these instructions carefully prior to installation. Please refer to your fitting instruction to ensure that the Roof Rack System is installed in the correct location. Check the contents of kit before commencing fitment and report any discrepancies. Place these instructions in the vehicle's glove box after installation is complete.

Note: Be sure to check Rhino-Rack website to see if you have the latest version of instructions before beginning installation.

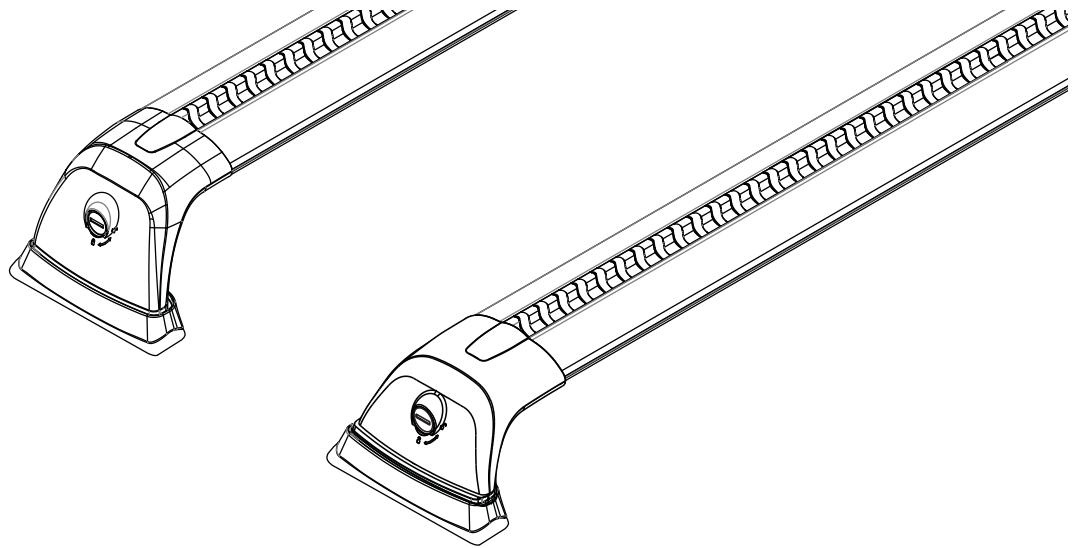

Important Information

- Check Part No./Kit is correct
- Read through instruction before installing
- Fit roof rack accessory
- Check and recheck all fasteners are secure

Maximum carrying capacity: Up to 100kg (220lbs) for a 2 bar system including the weight of the rack system. **Up to 150kg (330lbs) for a 3 bar system.** Please refer to your vehicle manufacturers handbook for maximum carrying capacity. Always use the lower of the two figures. Load must be evenly distributed over the entire basket.

Warning: Do not attempt to fit the rack system to your vehicle unless you fully understand these fitting instructions. Please direct any questions regarding fitting to the dealer from where the roof racks were purchased.

Use only non-stretch fastening ropes or straps.

Recommendations: It is essential that all bolt connections be checked after driving a short distance when you first install your roof racks. Bolt connections should be checked again at regular intervals (once a week is enough, depending on road conditions, usage, loads and distances travelled). You should also check the roof racks each time they are re-fitted. Always make sure to fasten your load securely. Please also ensure that all loads are evenly distributed and that the centre of gravity is kept as low as possible and must be entirely contained within the extents of the roof racks. **Rack System must be removed when putting vehicle through an automatic car wash.**

Caution: The handling characteristics of the vehicle changes when you transport a load on the roof. For safety reasons we recommend you exercise extreme care when transporting wind-resistant loads. Special consideration must be taken into account when cornering and braking.

Off-road use:

The Roof Rack System may be used in off road applications, however a safety factor of 1.5 is enforced. For example if the maximum permissible load is 100kg (220lbs) then the off road load is 66kg (145lbs). Although the crossbars are tested and approved to AS1235-2000/ 15011154, off-road conditions can be much more rigorous. Extreme care must be taken in off road conditions

Note for Dealers and Fitters:

It is your responsibility to ensure these fitting instructions are given to the end user or client.



RVL, RVH 2,4,6 Kits

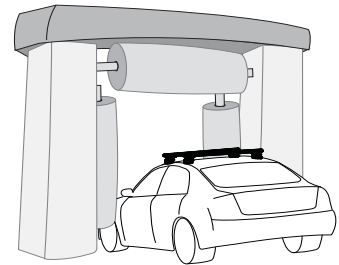
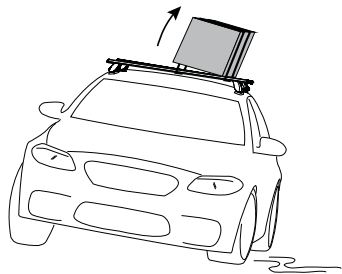
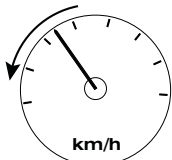
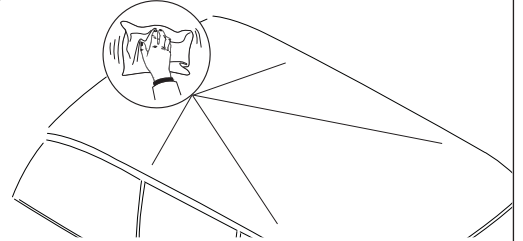
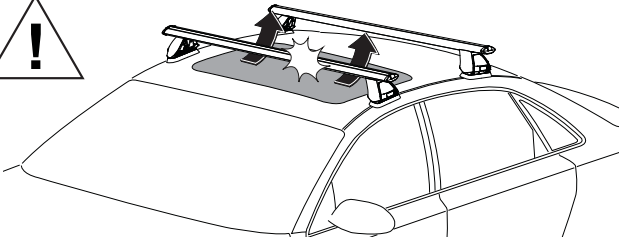
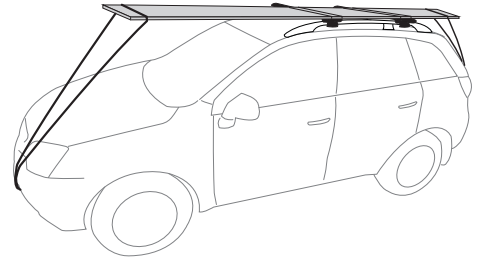
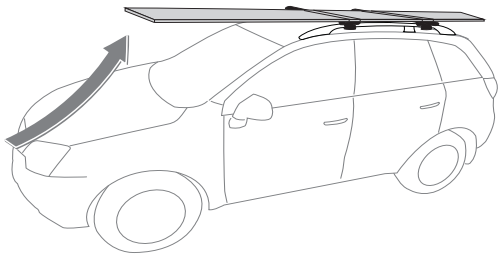

Ensure Ladder is well supported on the ground to help support tent. Take extreme caution when climbing heights above 1.2m/4ft.

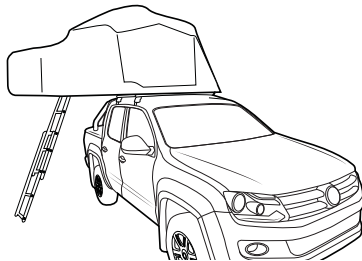

It is a requirement for Clam Shell Roof Top Tents to use a 3 Crossbar System.

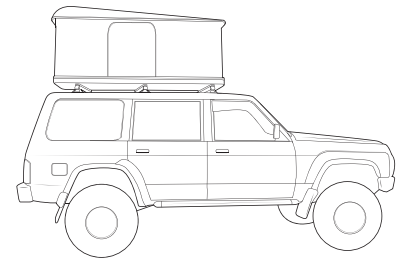

When these roof racks are to be used on a vehicle that is driven off sealed roads, the manufacturer maximum roof load rating (to be found in the vehicles User Manual) should be **divided by 1.5**. Do not forget to subtract the complete crossbar system weight from your maximum carrying capacity.

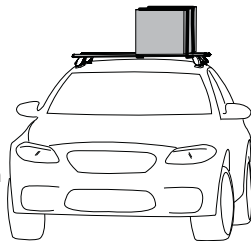

2 Bar System
100kg/220lbs
(Urban Road)



66kg/145lbs
(Off Road)

3 Bar System
150kg/220lbs
(Urban Road)



100kg/220lbs
(Off Road)

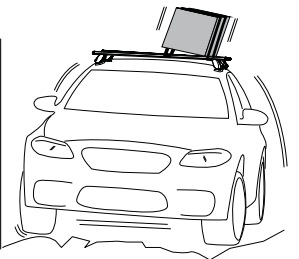

WARNING! Important Load Carrying Instructions

With utility vehicles, the cabin and the canopy move independently. Roof racks and vehicle can be damaged if the item transported is rigidly fixed at points on both the cabin and canopy. Instead, rigidly fix to either the cabin roof racks or the canopy roof racks.

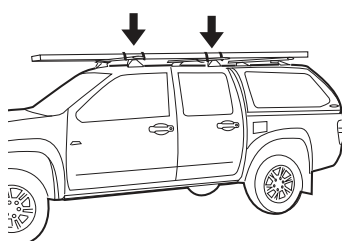
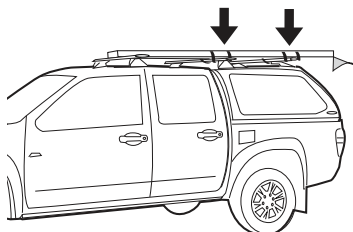

Paddle/ Surfboards should be fixed to the front of the vehicle.

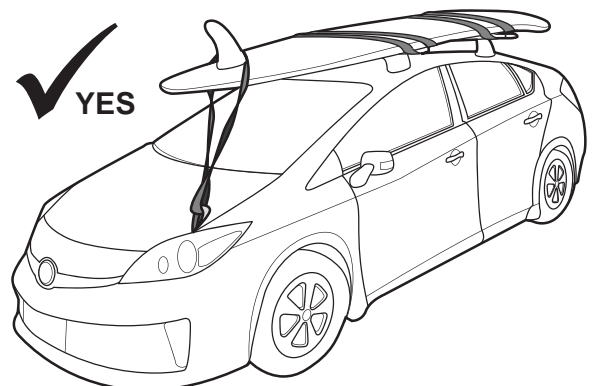



RVL, RVH 2,4,6 Kits

Parts List

Item	RVL	2 Kit Qty	4 Kit Qty	6 Kit Qty	Part No.
1	Locking Leg Cover (45mm)	2	4	6	M788
2	Locking Leg Base (45mm)	2	4	6	M787
3	Key Barrel	2	4	6	CA1339
4	Key	1	2	2	-
5	Allen Key	1	1	1	H021
6	Phillips Head Screw	2	4	6	B172
7	Instructions	1	1	1	R850
Item	RVH	2 Kit Qty	4 Kit Qty	6 Kit Qty	Part No.
8	Locking Leg Cover (65mm)	2	4	6	M786
9	Locking Leg Base (65mm)	2	4	6	M785
3	Key Barrel	2	4	6	CA1339
4	Key	1	2	2	-
5	Allen Key	1	1	1	H021
6	Phillips Head Screw	2	4	6	B172
7	Instructions	1	1	1	R850

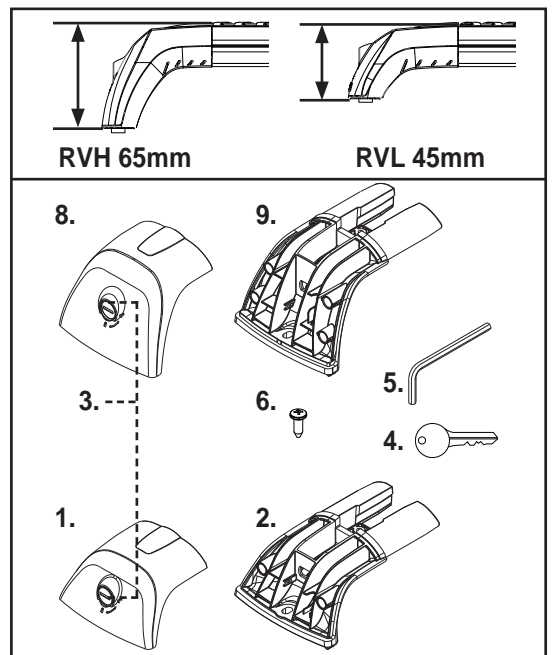

Notes:
Crossbars and Fit Kits are sold as separate and are required for individual vehicle fits.

Tools Required:
Allen Key (provided). Phillips Head Screw Driver.
Metal Key (provided). Drill with 4mm Drill Bit.

Instructions

- 1** Use the Metal Key provided to unlock the Locking Cover Plate and remove. Remove the Allen Key from its storage position.

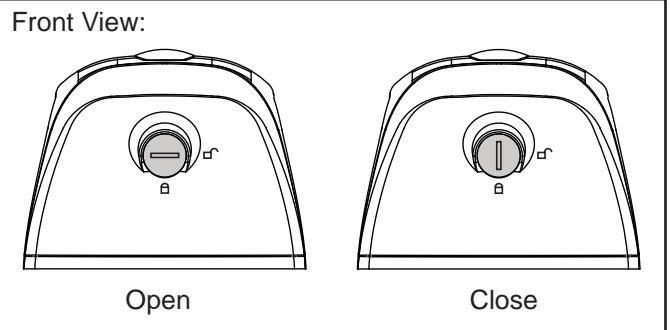
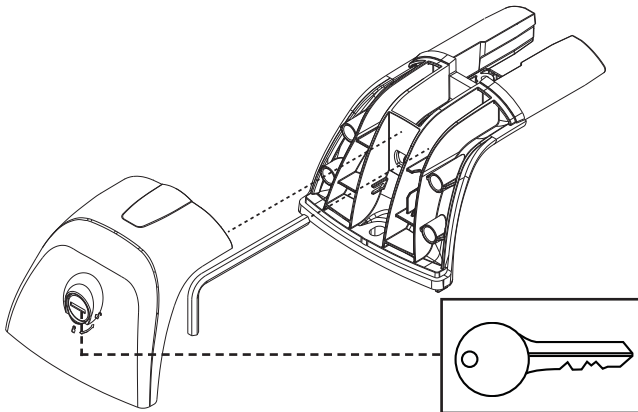

- 2** Insert the Locking Leg into the Crossbar. Fix in place using a Phillips Head Screw.

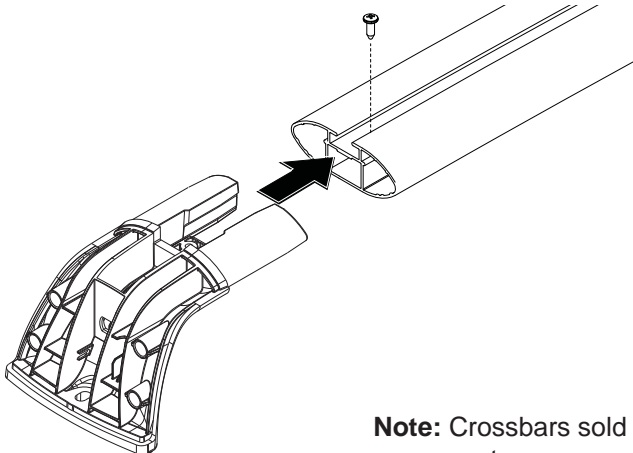

Note: Crossbars sold as separate.

- 3** Insert Vortex Rubber. Cut to size if required.

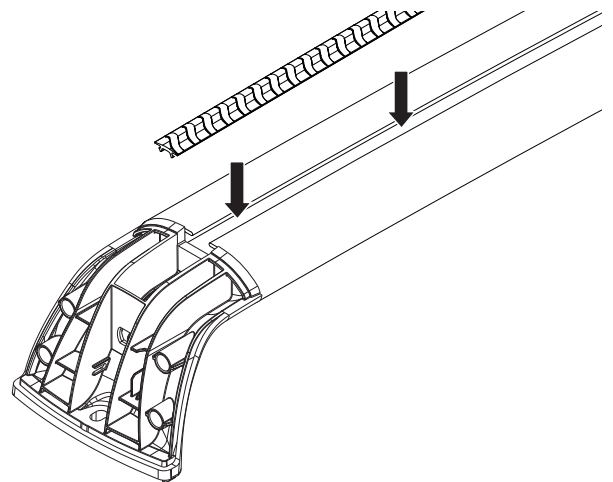



RVL, RVH 2,4,6 Kits

Installing to Tracks (RST fits)

- 1 Fix the completed Crossbars to the vehicle specific Base Kit that has been purchased using the Allen Key provided. Fit the crossbars to the tracks using an RTV-BK kit.

Note: Images are example only. RVL/RVH legs can be fit to either tracks or pads. Pads and track fit kits are sold as separate.

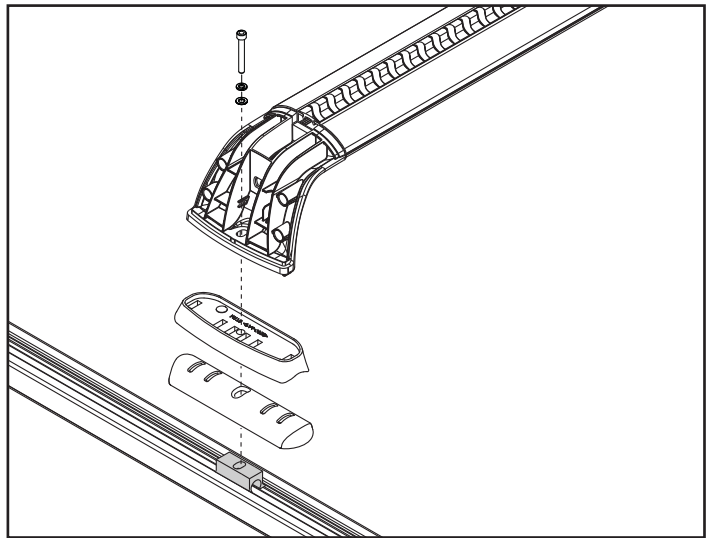

- 2 Replace the Allen Key and Cover Plate. Lock with Key Provided.

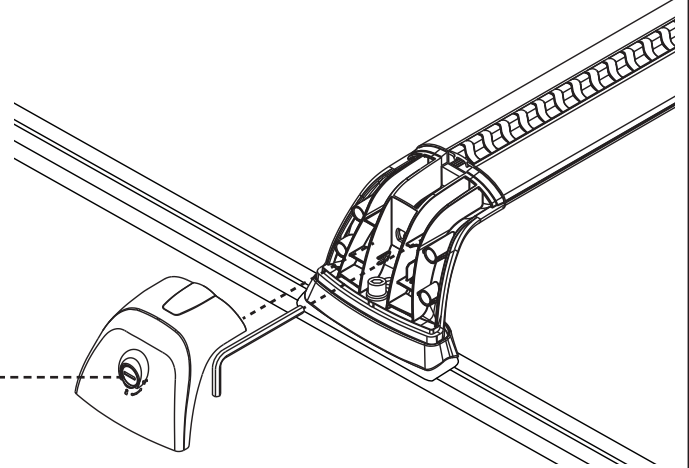
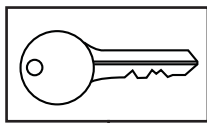

Note: Remove the Cover Plate and Vortex Rubber to gain access to the Crossbar C Channel. Crossbar accessories can be fitted here. Replace and lock the Cover Plate before use.

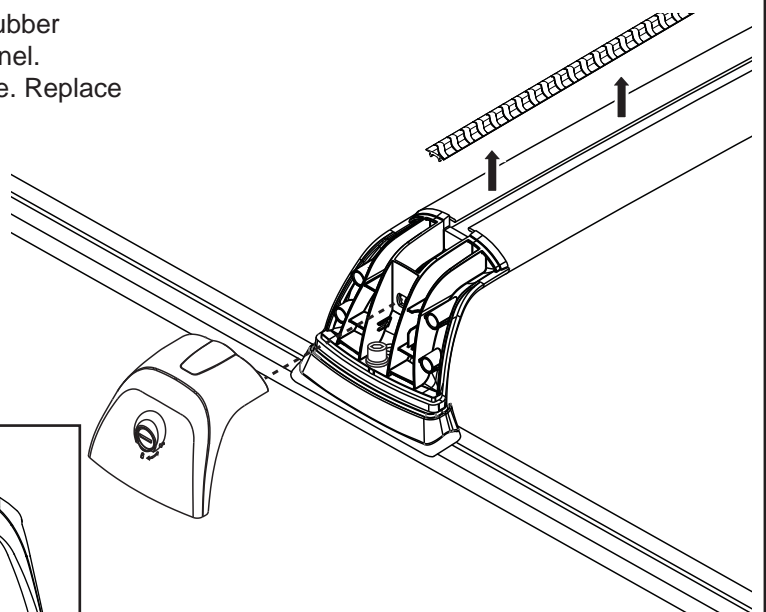

Front View:

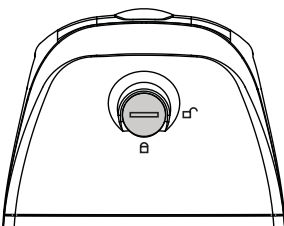

Open

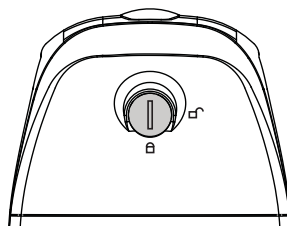

Close



RVL, RVH 2,4,6 Kits

Note: For installation direct to the roof of the vehicle (RSF fits), Refer to RCP-JB instructions (document number R1043)

Installing to Vortex Bars

- 1** Measure the desired length out **from the centre of the Vortex Bar** and create a reference with Marker. Carefully cut the bar at these markings using a Saw with an Alloy Cutting Blade.

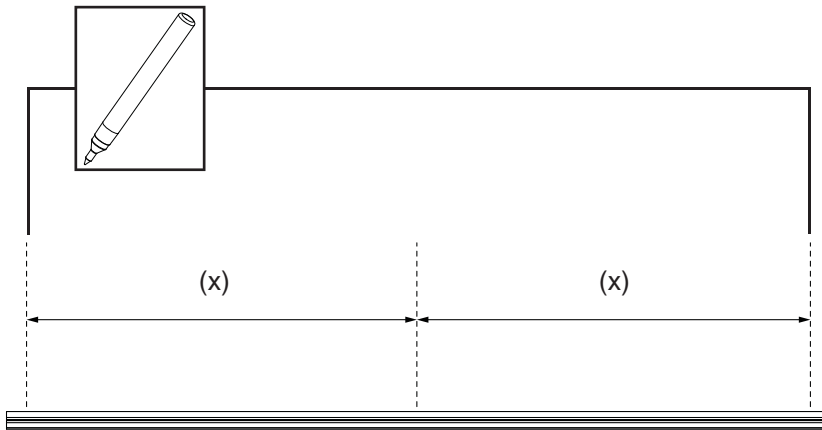

Side View: Always measure out from the centre of the bar to get the required size.

Cut the Bar at the required length.

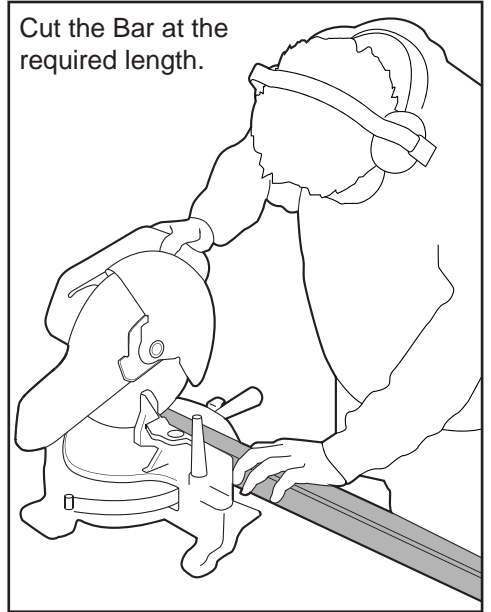

- 2** With the Bars cut, measure back 10.5mm from the end of the 'C' Channel and **drill a pilot hole in the centre of the channel**. Use a 4mm Drill Bit.

Top View: Measure 10.5mm back from the end of the 'C' Channel. Drill with a 4mm Drill Bit.

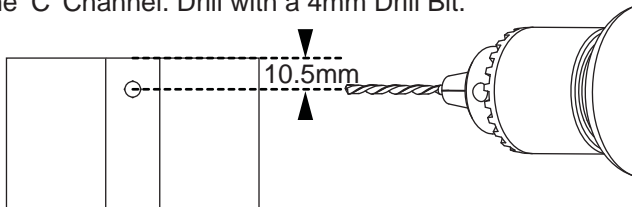

Note: RDJVA drill jig is available to ensure a precise fitment (sold as separate).

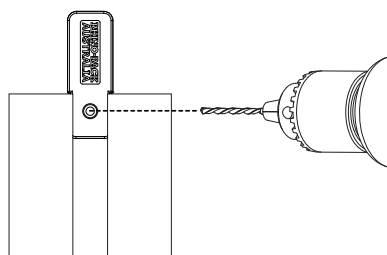

- 3** Insert the Locking Leg into the Crossbar.

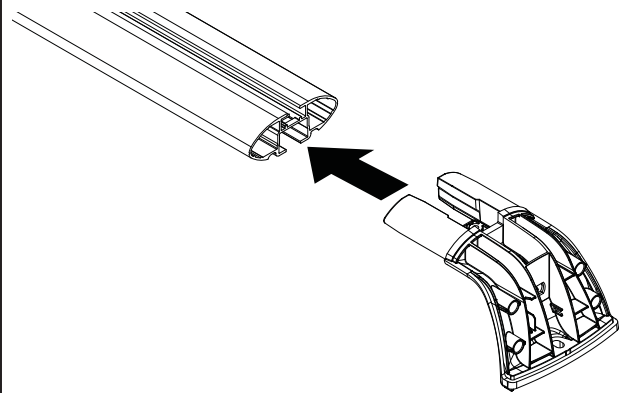

- 5** Insert Vortex Rubber. Cut to size if required.

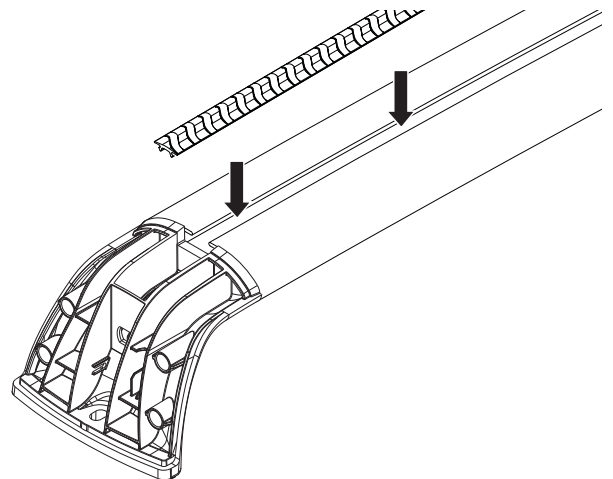

- 4** Screw the Locking Leg in place using a Phillips Head Screw.

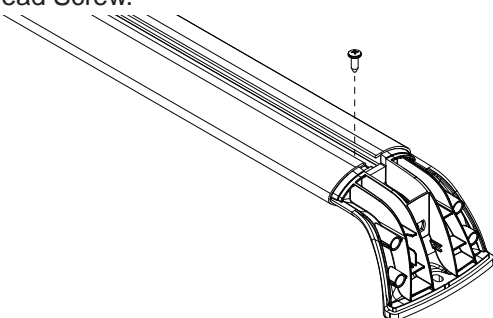



RVL, RVH 2,4,6 Kits

- 6** Cut the Vortex Underbar Strip to size and fit into the exposed slot as shown.

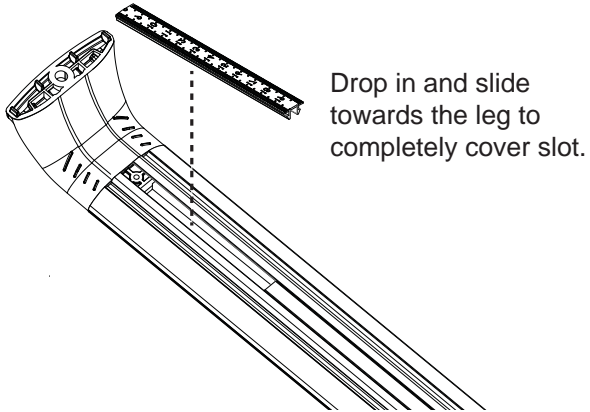
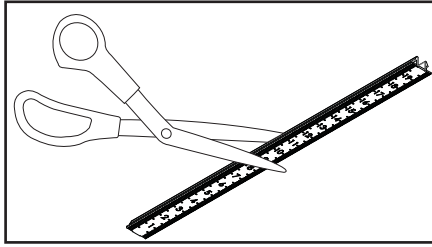

- 7** Fix the completed Crossbars to the vehicle specific Base Kit that has been purchased using the Allen Key provided.

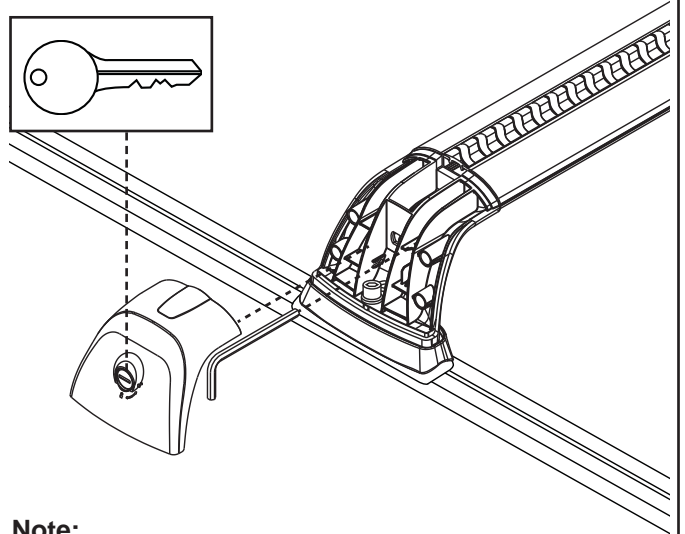

Note:
Fixture will vary vehicle to vehicle as will hardware. **Use the instructions within the Locking Base kit.**

- 8** Check all fixtures are secure before use.

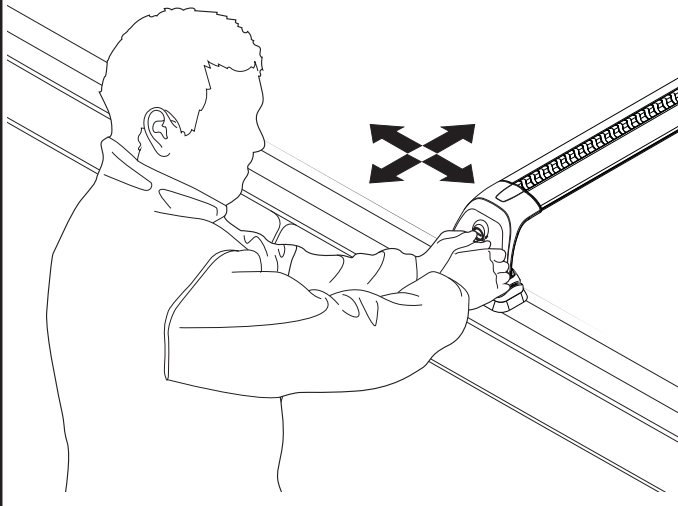



RHINO-RACK

RVP33 Supplement - Honda CRV 11/12

Important: Please read these instructions carefully prior to installation.
 Please refer to your fitting instruction to ensure that the Roof Rack System is installed in the correct location.
 Check the contents of kit before commencing fitment and report any discrepancies.
 Place these instructions in the vehicle's glove box after installation is complete.

Maximum load carrying capacity: 75kg/ 165lbs - 2 crossbars.

Leg kit: RVL4
Front bar: 966mm
Rear bar: 906mm
Base kit: RCP33-BK



Leg kit: RCL4
VA Bar: VA126S/B
Base kit: RCP33-BK

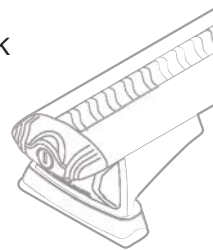

Leg kit: RCL4
HD Bar: RB1250S/B
Spacers: QMHD05
Base kit: RCP33-BK

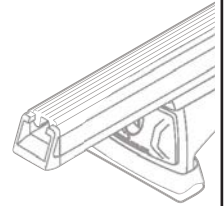

Note Vortex crossbars can be cut to length to fit this vehicle. Measure the desired length out **from the centre of the Vortex Bar** and create a reference with a marker. Carefully cut the bar at these markings using a Saw with an Alloy Cutting Blade.

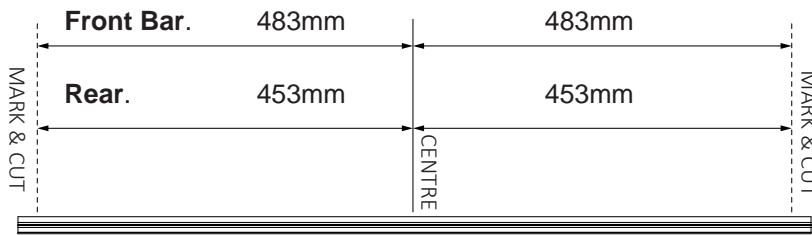

Cut the Bar at the required length.

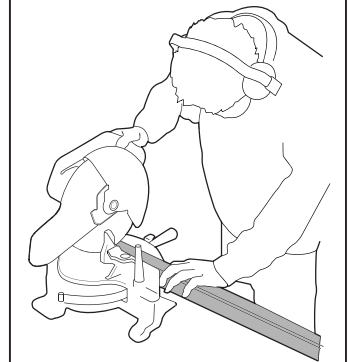

Note for dealers when altering a RSP kits:
 Add 38mm to sports bar measurement for RVL.
 Add 40mm to sports bar measurement for RVH.



RHINO-RACK

RCP33-BK Honda CR-V 30

Important: Please read these instructions carefully prior to installation. Please refer to your fitting instruction to ensure that the Roof Rack System is installed in the correct location. Check the contents of kit before commencing fitment and report any discrepancies. Place these instructions in the vehicle's glove box after installation is complete.

Layout:

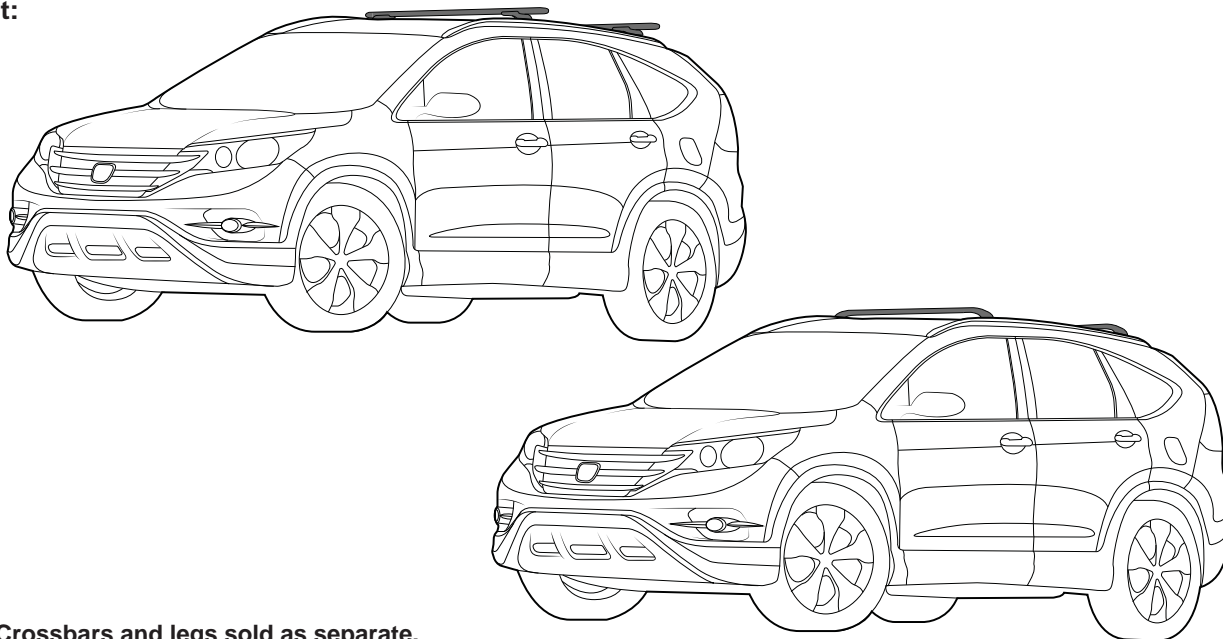

Note: Crossbars and legs sold as separate.

Important Information

- Check Part No./Kit is correct
- Read through instruction before installing
- Fit roof rack accessory
- Check and recheck all fasteners are secure

Maximum roof load: 75/165lbs evenly distributed across two crossbars. Refer to vehicle owners manual for maximum roof loading. Always use lower of the two figures. Note: Be sure to check Rhino-Rack website to see if you have the latest version of instructions before beginning installation.

Recommendations:

It is essential that all bolt connections be checked after driving a short distance when you first install your crossbars. Bolt connections should be checked and lubricated at regular intervals (probably once a week is enough, depending on road conditions, usage, loads and distances travelled). You should also check the crossbars each time they are refitted. Make sure to fasten your load securely. Please ensure that all loads are evenly distributed and that the centre of gravity is kept as low as possible.

Crossbars must be removed when putting vehicle through an automatic car wash.

Use only non-stretch fastening ropes or straps.

Caution: The handling characteristics of the vehicle changes when you transport a load on the roof. For safety reasons we recommend you exercise extreme care when transporting wind-resistant loads. Special consideration must be taken into account when cornering and braking.

Off-road Load Rating:

When crossbars are to be used in off-road conditions, please build a safety factor of 1.5 into this load limit for off-road use, 2 crossbars = **50kg 110lbs**. Although the crossbars are tested and approved to AS1235-2000, off-road conditions can be much more rigorous. However, increasing the number of crossbars does not increase the vehicles maximum permissible roof loading.

Note for Dealers and Fitters:

It is your responsibility to ensure instructions are given to the end user or client.

Rhino-Rack



Honda CR-V 30

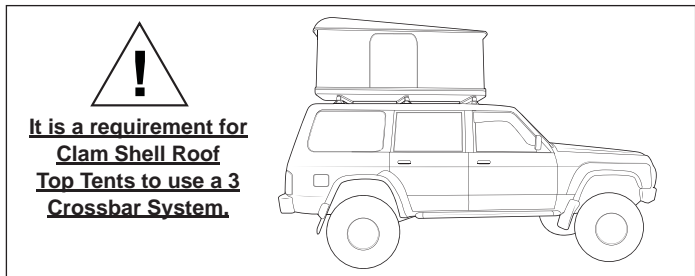
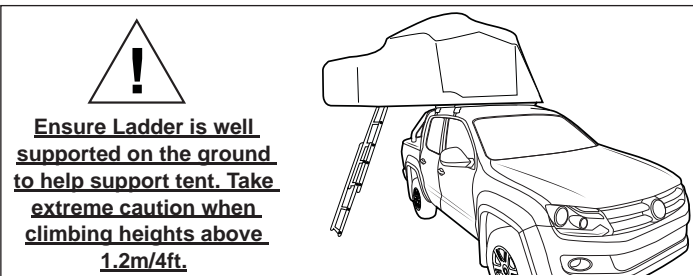
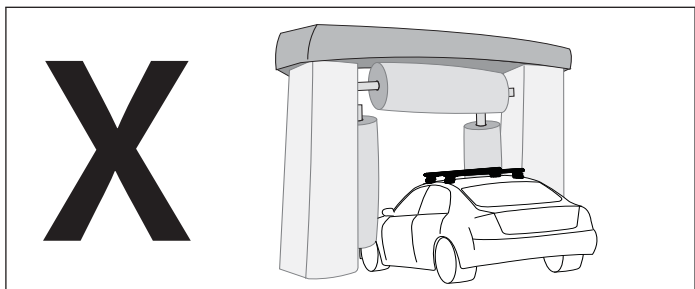
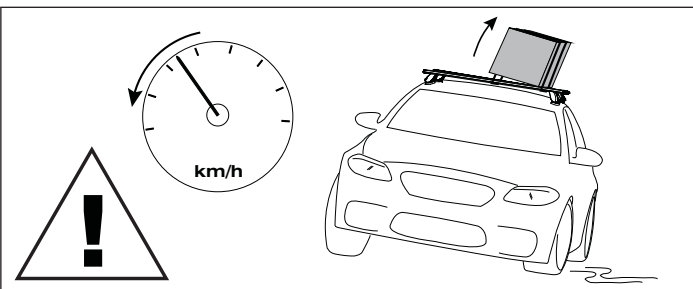
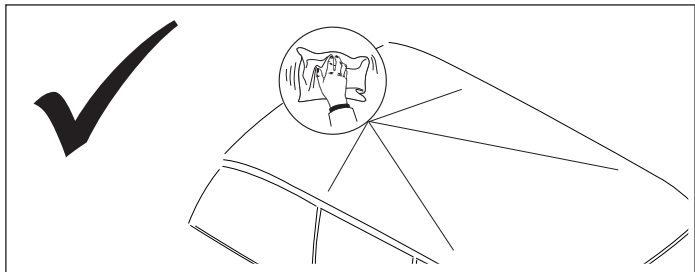
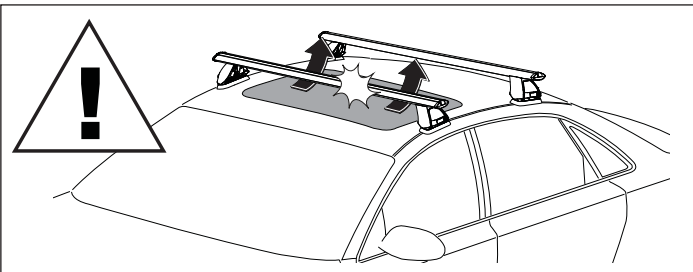
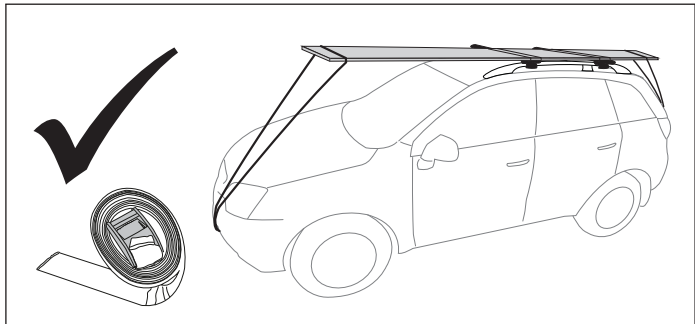
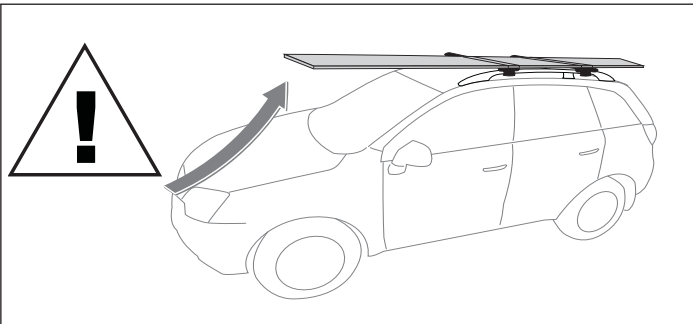

When these roof racks are to be used on a vehicle that is driven off sealed roads, the maximum roof rack load rating should be **divided by 1.5**. Do not forget to subtract 5kg from your maximum carrying capacity due to the weight of the crossbars and legs.

75kg/165lbs load rating (Urban road)	=	50kg/110lbs load rating (Off road - 75kg / 1.5)
---	---	--

WARNING! Important Load Carrying Instructions

With utility vehicles, the cabin and the canopy move independently. Roof racks and vehicle can be damaged if the item transported is rigidly fixed at points on both the cabin and canopy. Instead, rigidly fix to either the cabin roof racks or the canopy roof racks.

NO

YES

Paddle/ Surfboards should be fixed to the front of the vehicle.

YES



Honda CR-V 30

Parts List

Item	Components	Qty	Part No.
1	Bracket	4	CA1273
2	Rubber Skirt	4	M725
3	M6 x 16 Hex Setscrew	4	B168
4	M6 x 20 Socket Screw	8	B054
5	M6 Spring Washer	12	W004
6	M6 x 12.5mm Flat Washer	8	W003
7	M6 x 16mm Flat Washer	4	W031
8	5mm Security Allen Key	1	H021
9	Cover Plate	4	M126
10	M6 Washer (used on cover plate)	4	W003
11	Fitting Instructions	1	R1337

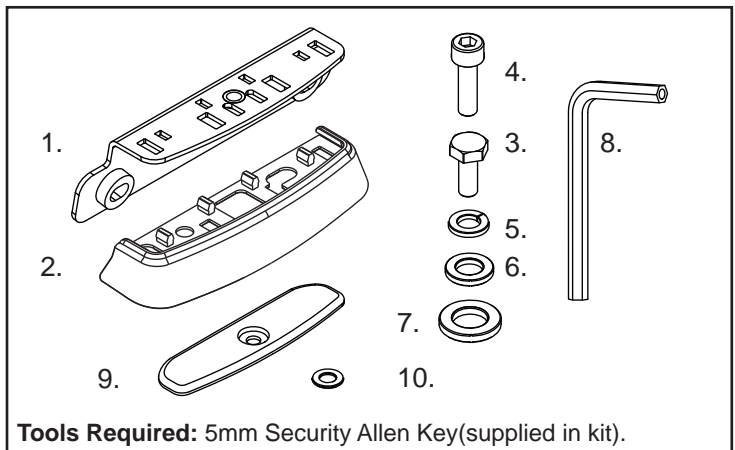

Instructions

1 Install the mounting bracket onto the rubber skirt. Note that the four locking points on the rubber skirt push through and fix onto the bracket.

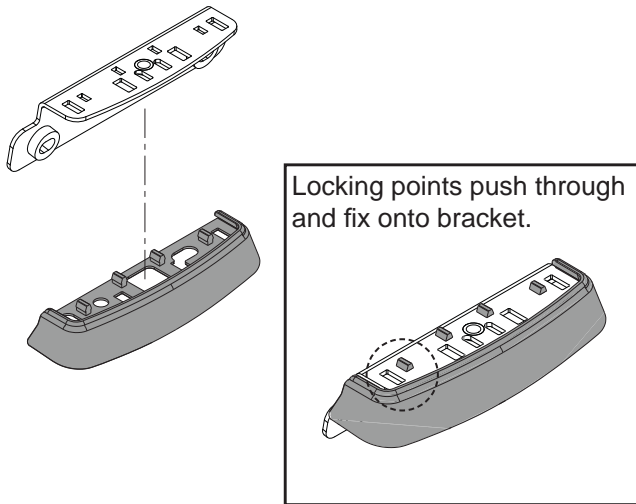

2 Remove rubber covers over threads on the factory rails. Fixture points are located on both rails facing inward. Install bracket assembly.

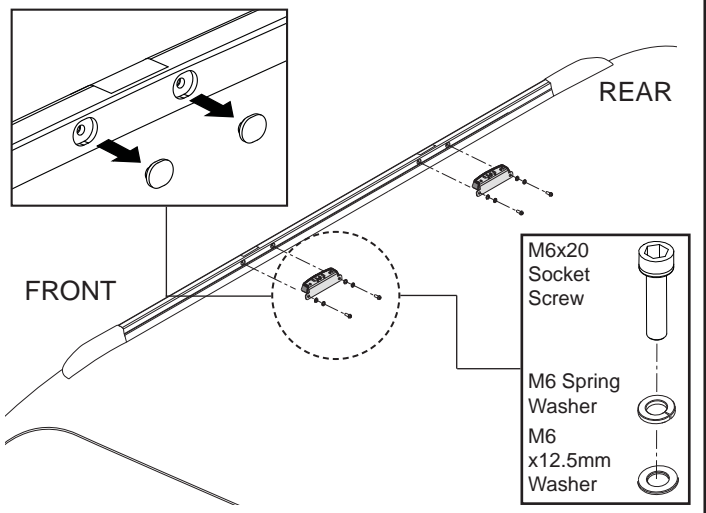

3 Fix the completed crossbars to the vehicle with an M6x16mm hex, M6 spring and flat washer (RVH shown as example only).

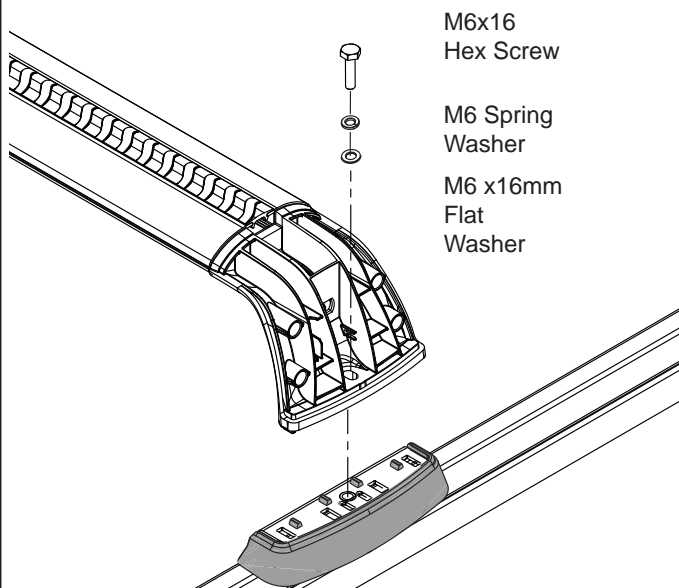

4 When crossbars are not in use, remove and install the cover plates as shown.

