



RHINO-RACK

RVL, RVH 2,4,6 Kits

Important: Please read these instructions carefully prior to installation. Please refer to your fitting instruction to ensure that the Roof Rack System is installed in the correct location. Check the contents of kit before commencing fitment and report any discrepancies. Place these instructions in the vehicle's glove box after installation is complete.

Note: Be sure to check Rhino-Rack website to see if you have the latest version of instructions before beginning installation.

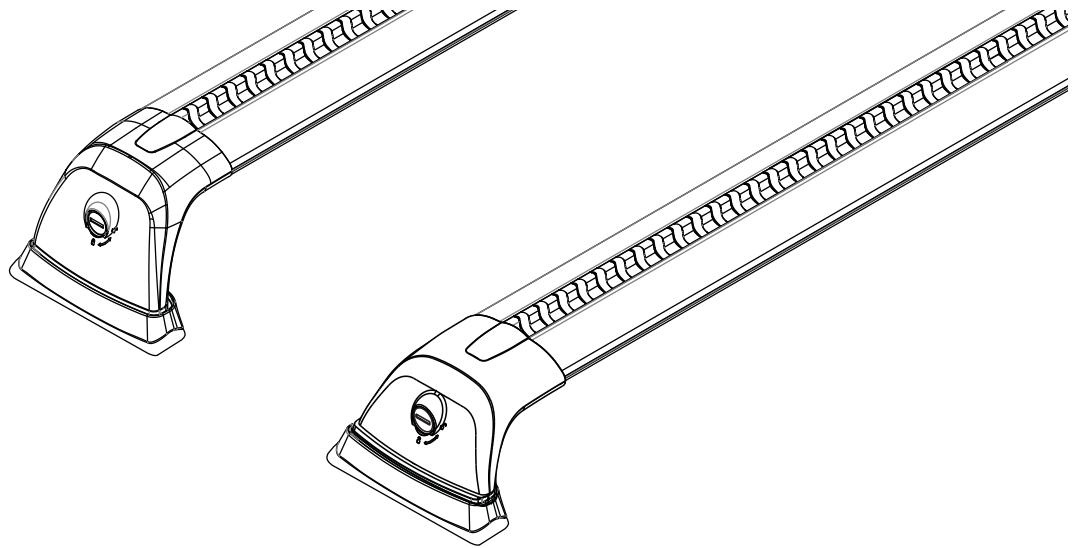

Important Information

- Check Part No./Kit is correct
- Read through instruction before installing
- Fit roof rack accessory
- Check and recheck all fasteners are secure

Maximum carrying capacity: Up to 100kg (220lbs) for a 2 bar system including the weight of the rack system. **Up to 150kg (330lbs) for a 3 bar system.** Please refer to your vehicle manufacturers handbook for maximum carrying capacity. Always use the lower of the two figures. Load must be evenly distributed over the entire basket.

Warning: Do not attempt to fit the rack system to your vehicle unless you fully understand these fitting instructions. Please direct any questions regarding fitting to the dealer from where the roof racks were purchased.

Use only non-stretch fastening ropes or straps.

Recommendations: It is essential that all bolt connections be checked after driving a short distance when you first install your roof racks. Bolt connections should be checked again at regular intervals (once a week is enough, depending on road conditions, usage, loads and distances travelled). You should also check the roof racks each time they are re-fitted. Always make sure to fasten your load securely. Please also ensure that all loads are evenly distributed and that the centre of gravity is kept as low as possible and must be entirely contained within the extents of the roof racks. **Rack System must be removed when putting vehicle through an automatic car wash.**

Caution: The handling characteristics of the vehicle changes when you transport a load on the roof. For safety reasons we recommend you exercise extreme care when transporting wind-resistant loads. Special consideration must be taken into account when cornering and braking.

Off-road use:

The Roof Rack System may be used in off road applications, however a safety factor of 1.5 is enforced. For example if the maximum permissible load is 100kg (220lbs) then the off road load is 66kg (145lbs). Although the crossbars are tested and approved to AS1235-2000/15011154, off-road conditions can be much more rigorous. Extreme care must be taken in off road conditions



RVL, RVH 2,4,6 Kits

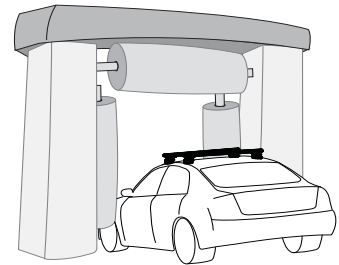
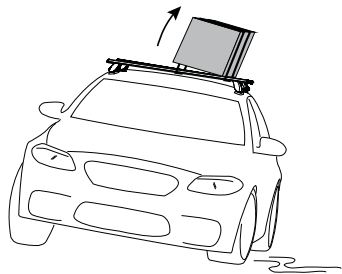
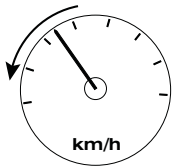
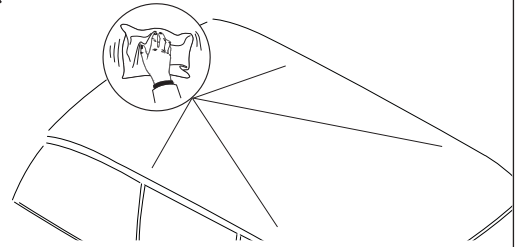
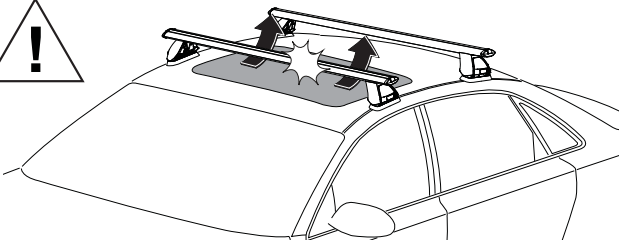
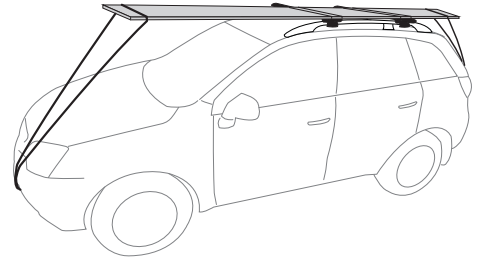
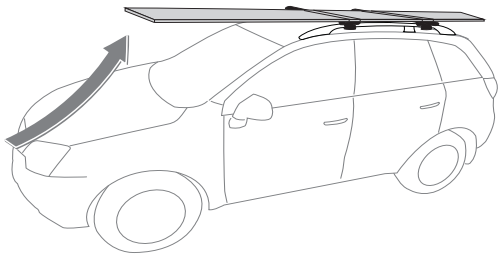

Ensure Ladder is well supported on the ground to help support tent. Take extreme caution when climbing heights above 1.2m/4ft.

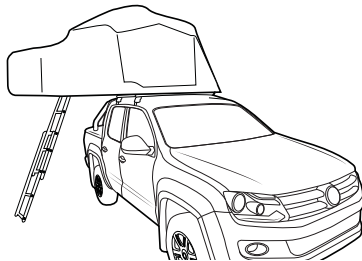

It is a requirement for Clam Shell Roof Top Tents to use a 3 Crossbar System.

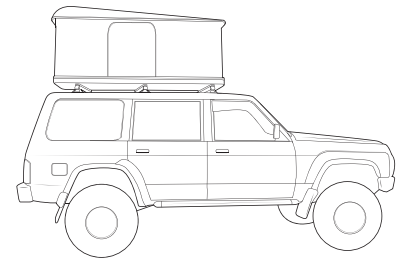

When these roof racks are to be used on a vehicle that is driven off sealed roads, the manufacturer maximum roof load rating (to be found in the vehicles User Manual) should be **divided by 1.5**. Do not forget to subtract the complete crossbar system weight from your maximum carrying capacity.

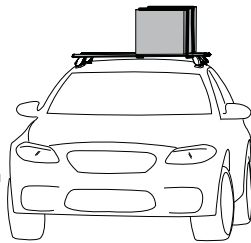

| | | |
|---------------------|---|---------------------|
| 2 Bar System | = | 66kg/145lbs |
| 100kg/220lbs | | (Off Road) |
| (Urban Road) | | |
| 3 Bar System | = | 100kg/220lbs |
| 150kg/220lbs | | (Off Road) |
| (Urban Road) | | |

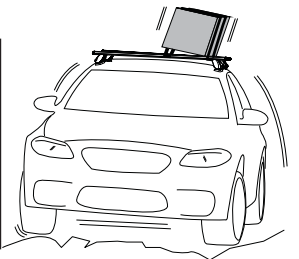

WARNING! Important Load Carrying Instructions

With utility vehicles, the cabin and the canopy move independently. Roof racks and vehicle can be damaged if the item transported is rigidly fixed at points on both the cabin and canopy. Instead, rigidly fix to either the cabin roof racks or the canopy roof racks.

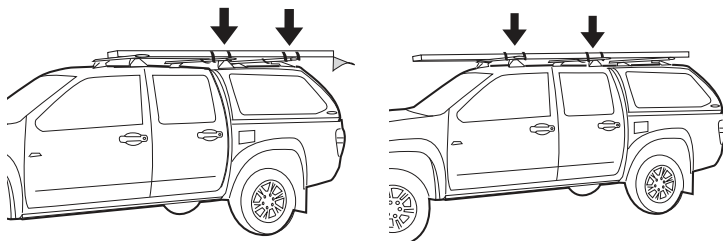

Paddle/ Surfboards should be fixed to the front of the vehicle.

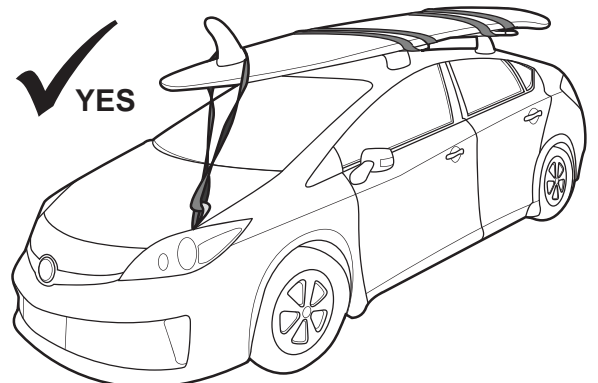



RVL, RVH 2,4,6 Kits

Parts List

| Item | RVL | 2 Kit Qty | 4 Kit Qty | 6 Kit Qty | Part No. |
|------|--------------------------|-----------|-----------|-----------|----------|
| 1 | Locking Leg Cover (45mm) | 2 | 4 | 6 | M788 |
| 2 | Locking Leg Base (45mm) | 2 | 4 | 6 | M787 |
| 3 | Key Barrel | 2 | 4 | 6 | CA1339 |
| 4 | Key | 1 | 2 | 2 | - |
| 5 | Allen Key | 1 | 1 | 1 | H021 |
| 6 | Phillips Head Screw | 2 | 4 | 6 | B172 |
| 7 | Instructions | 1 | 1 | 1 | R850 |
| Item | RVH | 2 Kit Qty | 4 Kit Qty | 6 Kit Qty | Part No. |
| 8 | Locking Leg Cover (65mm) | 2 | 4 | 6 | M786 |
| 9 | Locking Leg Base (65mm) | 2 | 4 | 6 | M785 |
| 3 | Key Barrel | 2 | 4 | 6 | CA1339 |
| 4 | Key | 1 | 2 | 2 | - |
| 5 | Allen Key | 1 | 1 | 1 | H021 |
| 6 | Phillips Head Screw | 2 | 4 | 6 | B172 |
| 7 | Instructions | 1 | 1 | 1 | R850 |

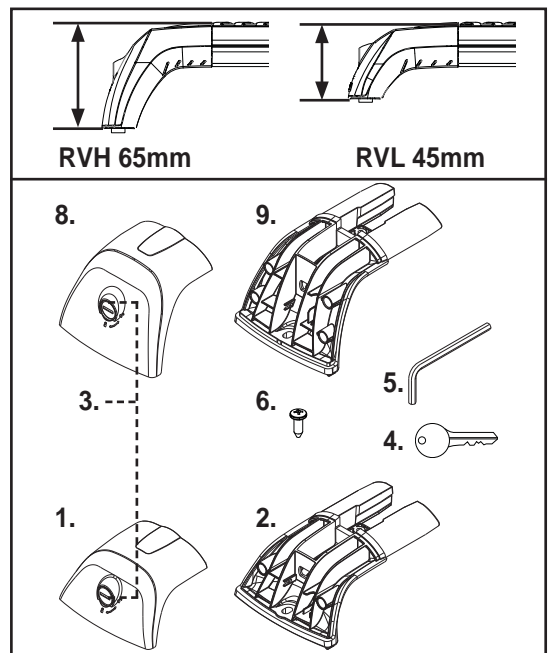

Notes:
Crossbars and Fit Kits are sold as separate and are required for individual vehicle fits.

Tools Required:
Allen Key (provided). Phillips Head Screw Driver.
Metal Key (provided). Drill with 4mm Drill Bit.

Instructions

1 Use the Metal Key provided to unlock the Locking Cover Plate and remove. Remove the Allen Key from its storage position.

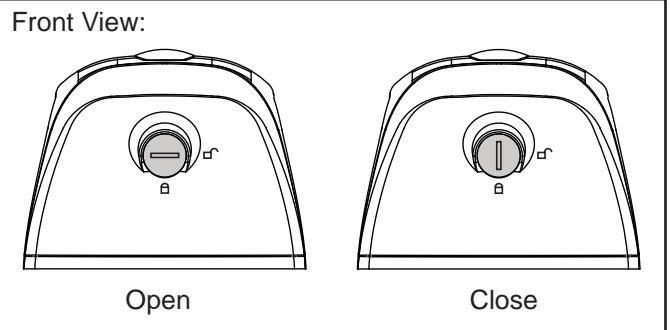
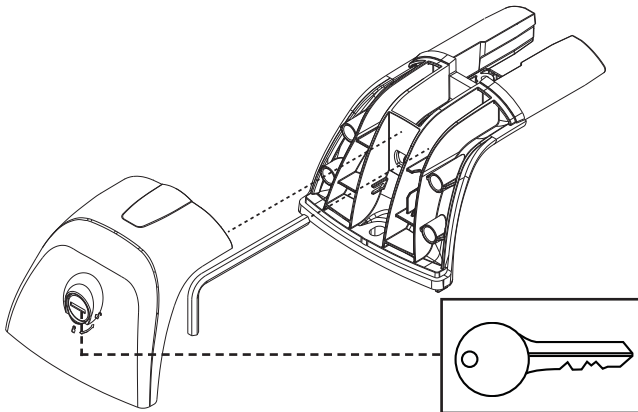

2 Insert the Locking Leg into the Crossbar. Fix in place using a Phillips Head Screw.

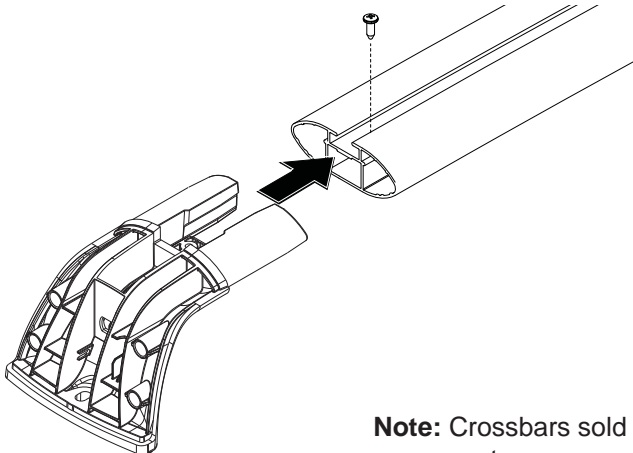

Note: Crossbars sold as separate.

3 Insert Vortex Rubber. Cut to size if required.

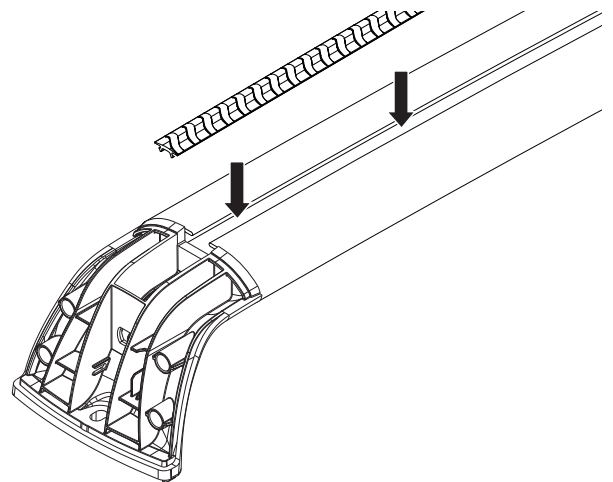



RVL, RVH 2,4,6 Kits

Installing to Tracks (RST fits)

- 1 Fix the completed Crossbars to the vehicle specific Base Kit that has been purchased using the Allen Key provided. Fit the crossbars to the tracks using an RTV-BK kit.

Note: Images are example only. RVL/RVH legs can be fit to either tracks or pads. Pads and track fit kits are sold as separate.

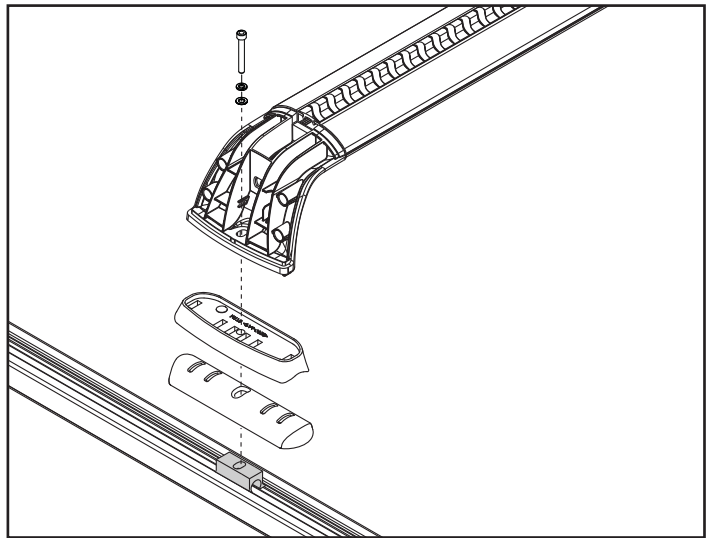

- 2 Replace the Allen Key and Cover Plate. Lock with Key Provided.

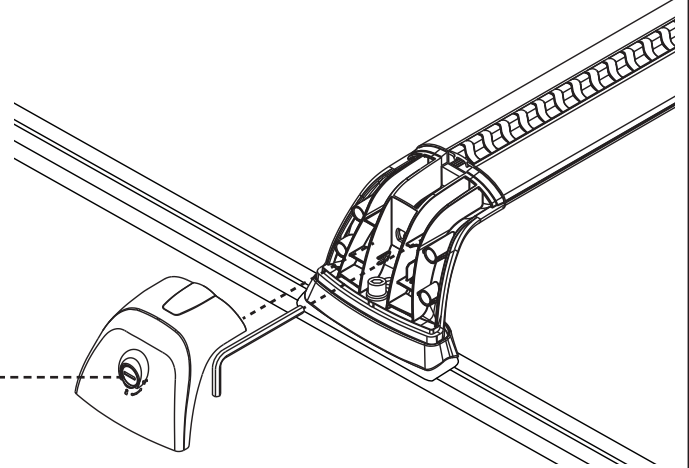
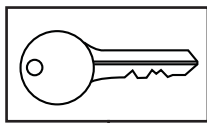

Note: Remove the Cover Plate and Vortex Rubber to gain access to the Crossbar C Channel. Crossbar accessories can be fitted here. Replace and lock the Cover Plate before use.

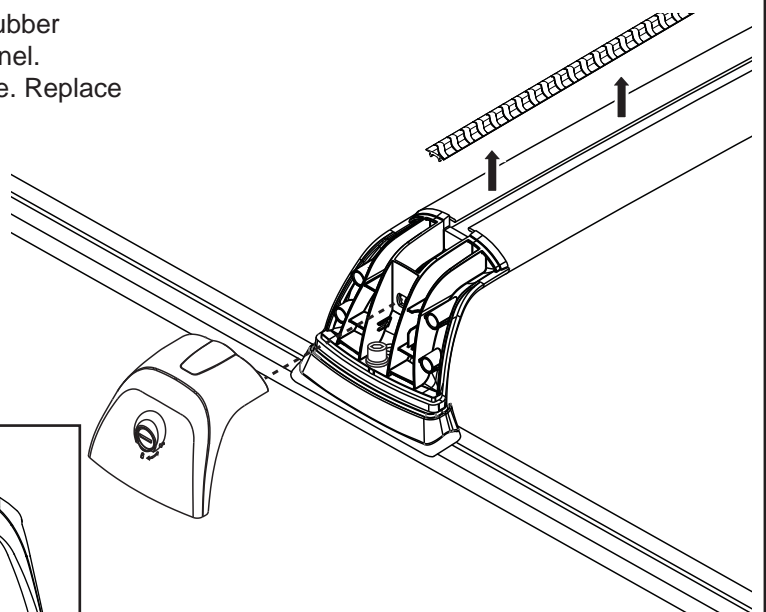

Front View:

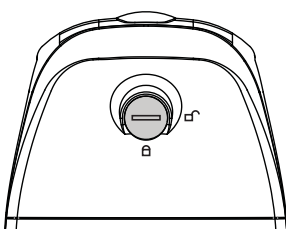

Open

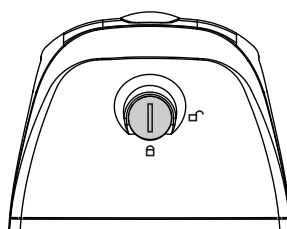

Close



RVL, RVH 2,4,6 Kits

Note: For installation direct to the roof of the vehicle (RSF fits), Refer to RCP-JB instructions (document number R1043)

Installing to Vortex Bars

- 1** Measure the desired length out **from the centre of the Vortex Bar** and create a reference with Marker. Carefully cut the bar at these markings using a Saw with an Alloy Cutting Blade.

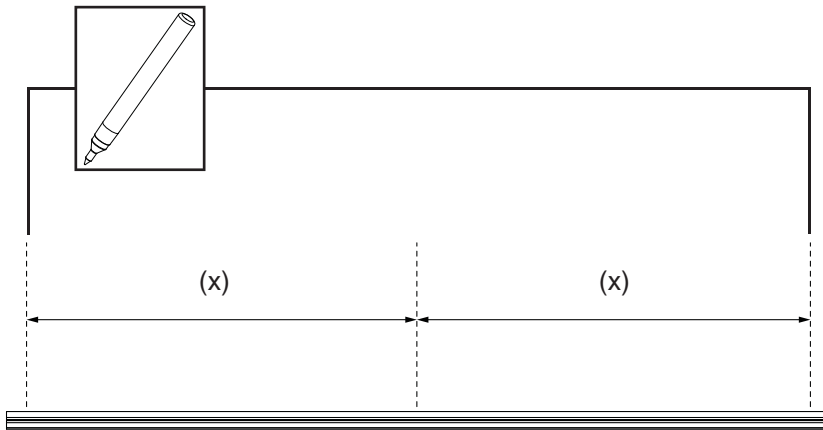

Side View: Always measure out from the centre of the bar to get the required size.

Cut the Bar at the required length.

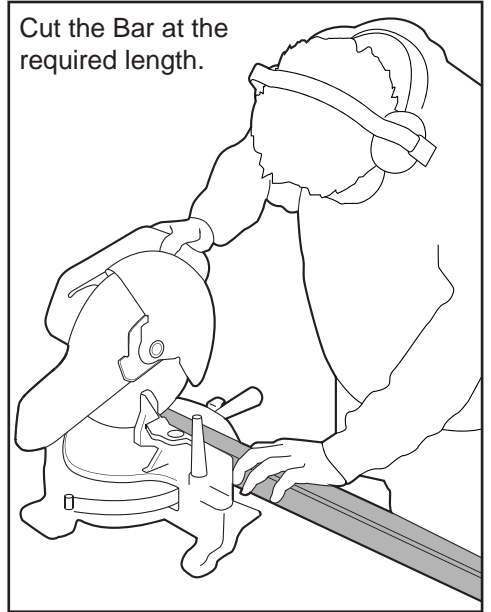

- 2** With the Bars cut, measure back 10.5mm from the end of the 'C' Channel and **drill a pilot hole in the centre of the channel**. Use a 4mm Drill Bit.

Top View: Measure 10.5mm back from the end of the 'C' Channel. Drill with a 4mm Drill Bit.

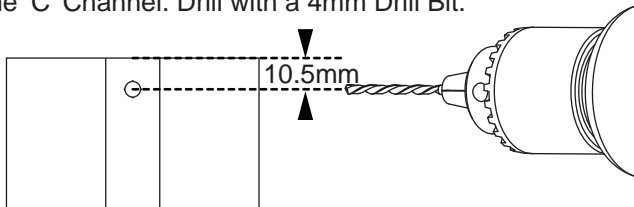

Note: RDJVA drill jig is available to ensure a precise fitment (sold as separate).

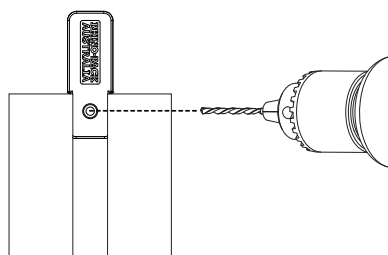

- 3** Insert the Locking Leg into the Crossbar.

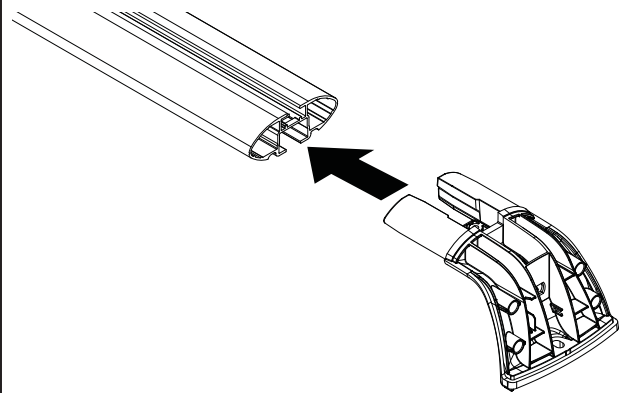

- 5** Insert Vortex Rubber. Cut to size if required.

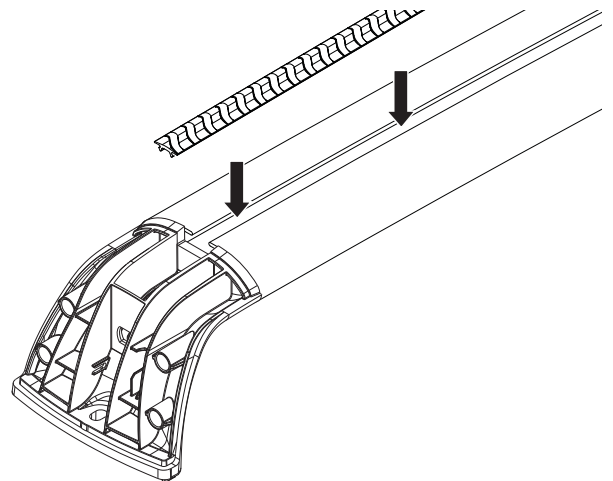

- 4** Screw the Locking Leg in place using a Phillips Head Screw.

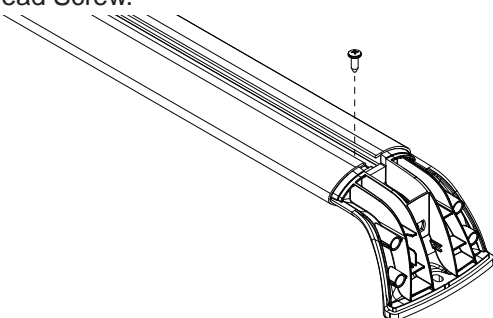



RVL, RVH 2,4,6 Kits

- 6** Cut the Vortex Underbar Strip to size and fit into the exposed slot as shown.

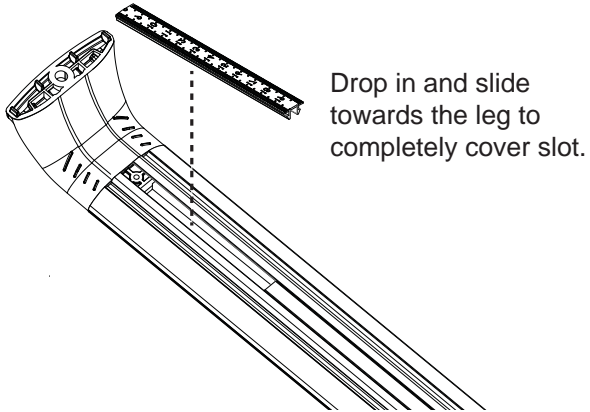
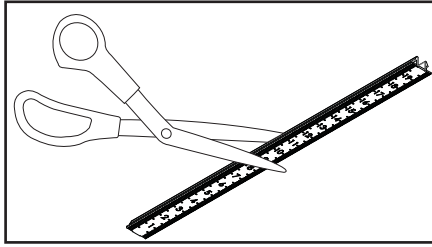

- 7** Fix the completed Crossbars to the vehicle specific Base Kit that has been purchased using the Allen Key provided.

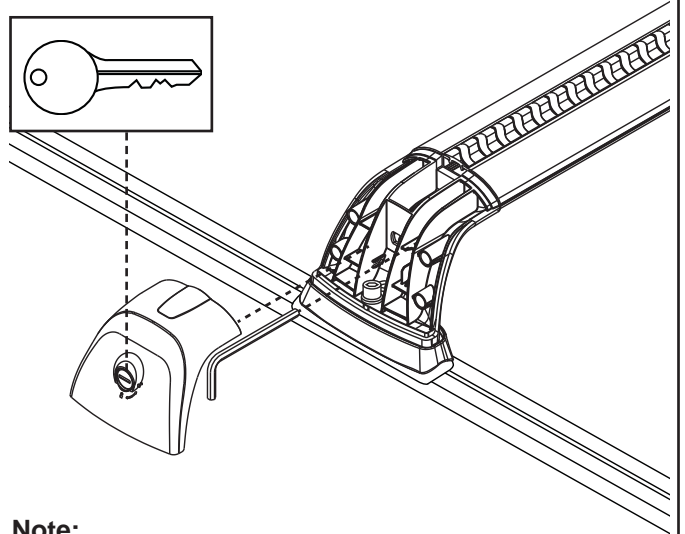

Note:
Fixture will vary vehicle to vehicle as will hardware. **Use the instructions within the Locking Base kit.**

- 8** Check all fixtures are secure before use.

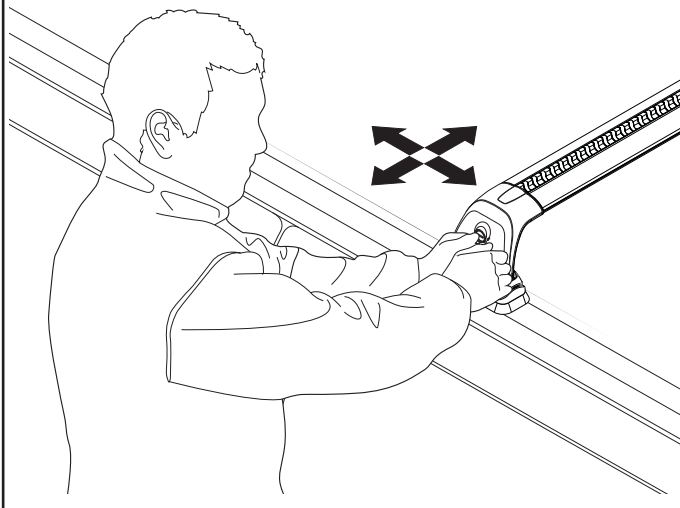



RHINO-RACK

RVP37 Supplement - Toyota Kluger/Highlander XU50 3/14

Important: Please read these instructions carefully prior to installation.
Please refer to your fitting instruction to ensure that the Roof Rack System is installed in the correct location.
Check the contents of kit before commencing fitment and report any discrepancies.
Place these instructions in the vehicle's glove box after installation is complete.

Maximum load carrying capacity: 45kg/ 99lbs - 2 crossbars.

Leg kit: RVL4
Front bar: 1050mm
Rear bar: 1006mm
Base kit: RCP37-BK



Leg kit: RCL4
VA Bar: VA106S/B
Base kit: RCP37-BK

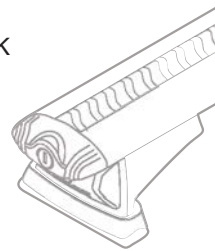

Leg kit: RCL4
HD Bar: RB1250S/B
Spacers: QMHD05
Base kit: RCP37-BK

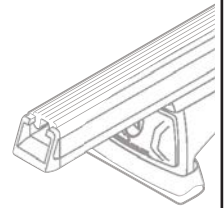

Note Vortex crossbars can be cut to length to fit this vehicle. Measure the desired length out **from the centre of the Vortex Bar** and create a reference with a marker. Carefully cut the bar at these markings using a Saw with an Alloy Cutting Blade.

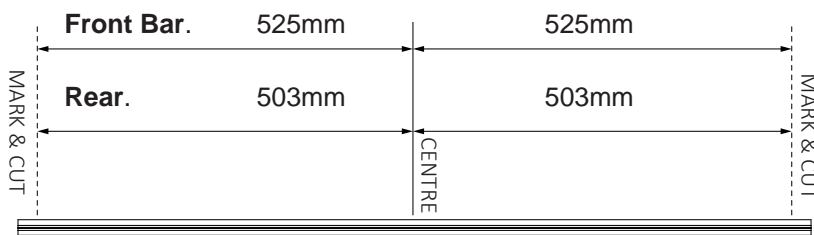

Cut the Bar at the required length.

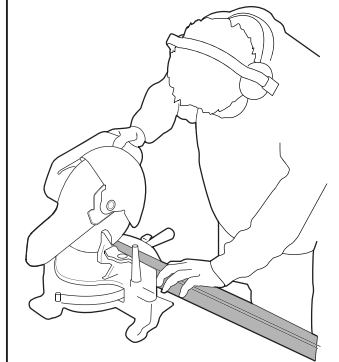

Note for dealers when altering a RSP kits:
Add 38mm to sports bar measurement for RVL.
Add 40mm to sports bar measurement for RVH.



RHINO-RACK

Toyota Kluger/Highlander SUV XU50 RCP37-BK

Important: Please read these instructions carefully prior to installation.
Please refer to your fitting instruction to ensure that the Roof Rack System is installed in the correct location.
Check the contents of kit before commencing fitment and report any discrepancies.
Place these instructions in the vehicle's glove box after installation is complete.

Layout:

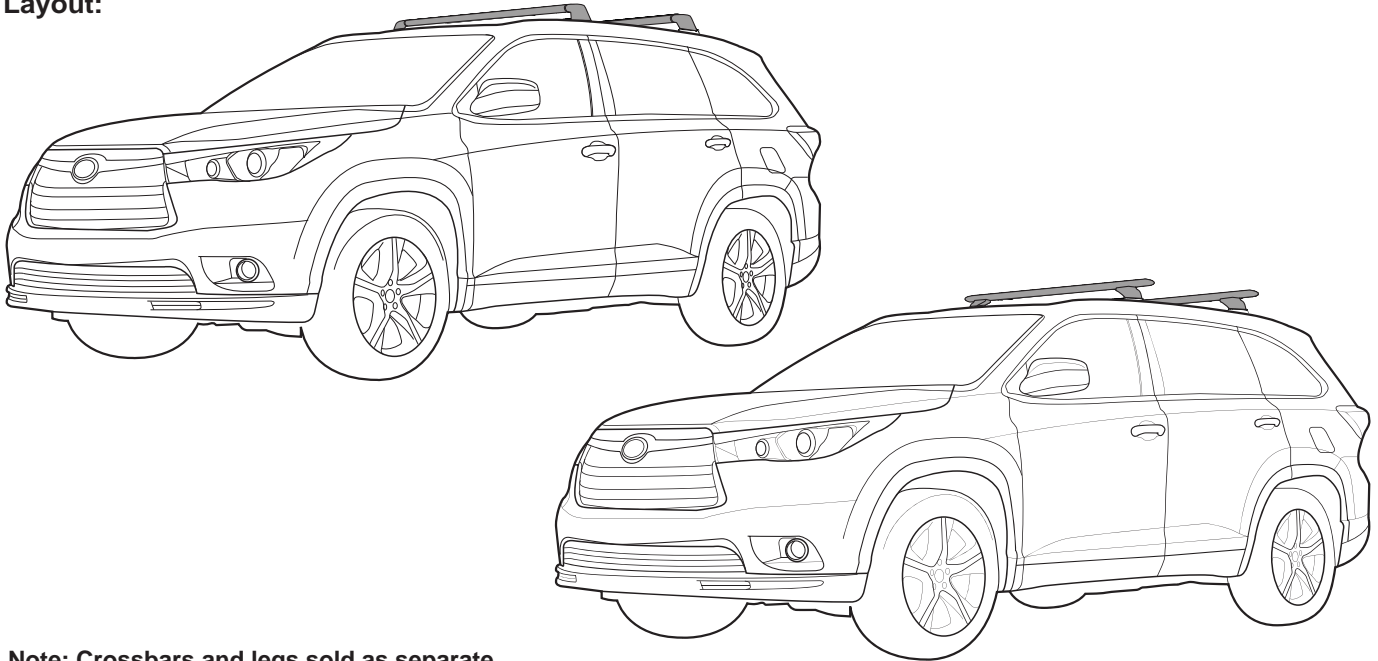

Note: Crossbars and legs sold as separate.

Important Information

1. Check Part No./Kit is correct
2. Read through instruction before installing
3. Fit roof rack accessory
4. Check and recheck all fasteners are secure

Maximum carrying capacity: 80kg (176lbs) including the weight of the rack system **5kg (11lbs)**. **Note: Be sure to check Rhino-Rack website to see if you have the latest version of instructions before beginning installation.**

Please refer to your vehicle manufacturers handbook for maximum carrying capacity. Always use the lower of the two figures. Load must be evenly distributed over the entire basket.

Warning: Do not attempt to fit the roof rack system to your vehicle unless you fully understand these fitting instructions. Please direct any questions regarding fitting to the dealer from where the roof racks were purchased.

Use only non-stretch fastening ropes or straps.

Recommendations: It is essential that all bolt connections be checked after driving a short distance when you first install your roof racks. Bolt connections should be checked again at regular intervals (once a week is enough, depending on road conditions, usage, loads and distances travelled). You should also check the roof racks each time they are re-fitted. Always make sure to fasten your load securely. Please also ensure that all loads are evenly distributed and that the centre of gravity is kept as low as possible and must be entirely contained within the extents of the roof racks.

Caution: The handling characteristics of the vehicle changes when you transport a load on the roof. For safety reasons we recommend you exercise extreme care when transporting wind-resistant loads. Special consideration must be taken into account when cornering and braking.

Off-road use:

The Roof Rack System may be used in off road applications, however a safety factor of 1.5 is enforced. That is, maximum permissible off road load is **53kg (117lbs)**. Although the crossbars are tested and approved to AS1235-2000, off-road conditions can be much more rigorous. Increasing the number of crossbars does not increase the vehicles maximum permissible roof loading.

Note for Dealers and Fitters:

It is your responsibility to ensure these fitting instructions are given to the end user or client.



Toyota Kluger/Highlander SUV XU50 RCP37-BK

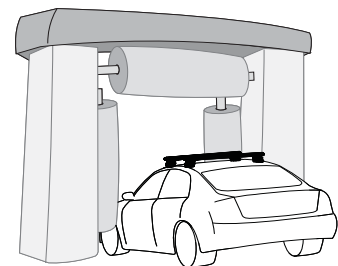
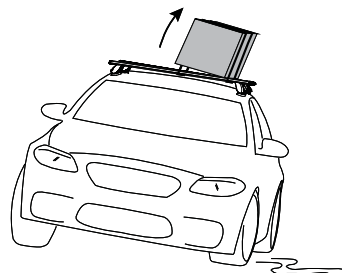
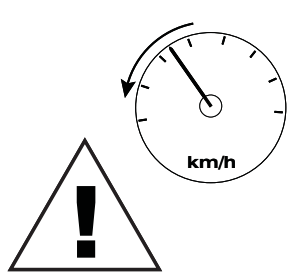
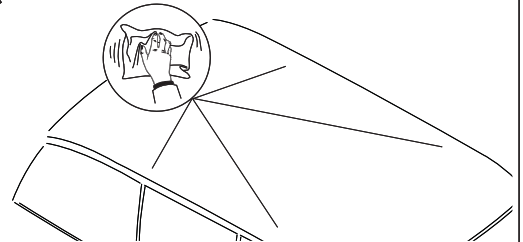
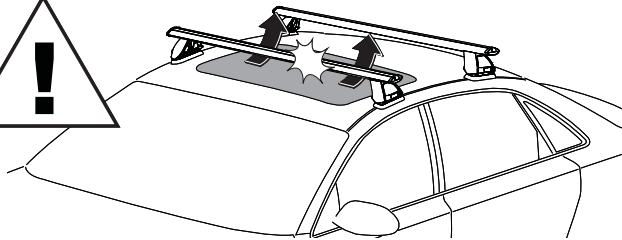
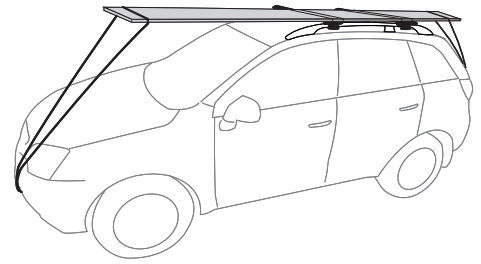
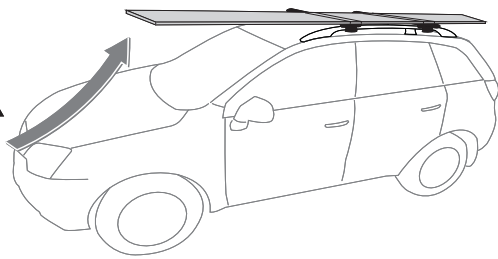

Ensure Ladder is well supported on the ground to help support tent. Take extreme caution when climbing heights above 1.2m/4ft.

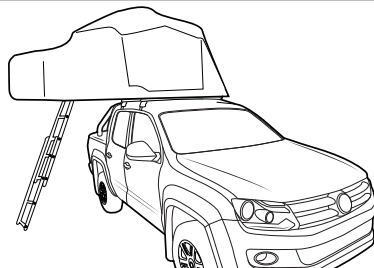

It is a requirement for Clam Shell Roof Top Tents to use a 3 Crossbar System.

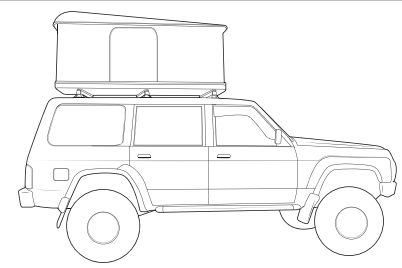

When these roof racks are to be used on a vehicle that is driven off sealed roads, the maximum roof rack load rating should be **divided by 1.5**. Do not forget to subtract 5kg from your maximum carrying capacity due to the weight of the crossbars and legs.

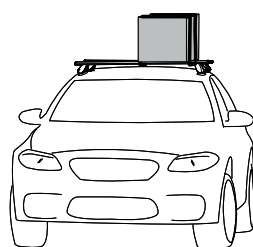

80kg/176lbs
load rating
(Urban road)

53kg/117lbs
load rating
(Off road
- 80kg / 1.5)

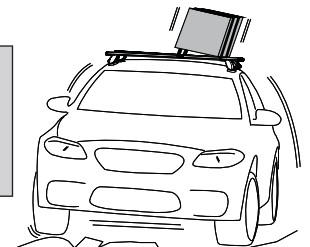

WARNING! Important Load Carrying Instructions

With utility vehicles, the cabin and the canopy move independently. Roof racks and vehicle can be damaged if the item transported is rigidly fixed at points on both the cabin and canopy. Instead, rigidly fix to either the cabin roof racks or the canopy roof racks.

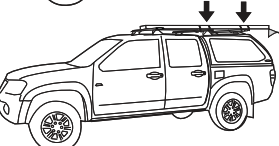
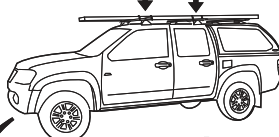
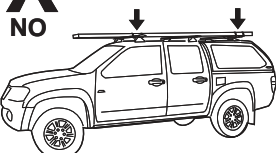

Paddle/ Surfboards should be fixed to the front of the vehicle.

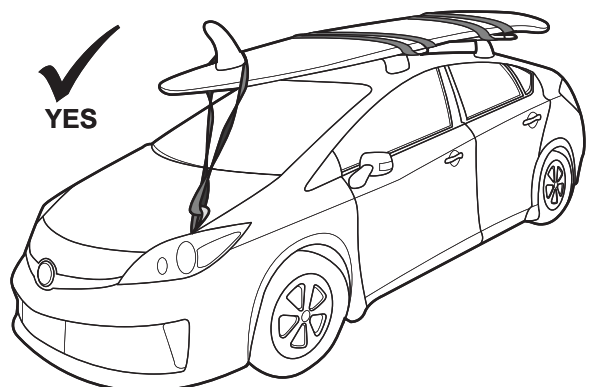



Toyota Kluger/Highlander SUV XU50 RCP37-BK

Parts List

| Item | Component Name | Qty | Part No. |
|------|---------------------------------|-----|----------|
| 1 | M6 x 30mm Hex Setscrew | 4 | B202 |
| 2 | M6 Spring Washer | 4 | W004 |
| 3 | M6 x 16mm Flat Washer | 4 | W031 |
| 4 | M8 x 40mm Socket Screw | 8 | B162T |
| 5 | M8 Spring Washer | 8 | W019 |
| 6 | M8 Flat Washer | 8 | W043 |
| 7 | 7mm x 4mm O-Ring | 8 | C299 |
| 8 | Front Left Mount Pad | 1 | M391 |
| 9 | Front Right Mount Pad | 1 | M392 |
| 10 | Rear Left Mount Pad | 1 | M393 |
| 11 | Rear Right Mount Pad | 1 | M394 |
| 12 | Left Pad Mount Skirt | 2 | M395 |
| 13 | Right Pad Mount Skirt | 2 | M396 |
| 14 | Mounting Pad Washer | 8 | C588 |
| 15 | 6mm Hex Allen Key | 1 | H009 |
| 16 | M6 Washer (used on cover plate) | 4 | W003 |
| 17 | Cover Plate | 4 | M126 |
| 18 | Fitting Instruction | 1 | R1338 |

Tools Required:

Flat screwdriver.
Socket wrench
10mm,
13mm socket

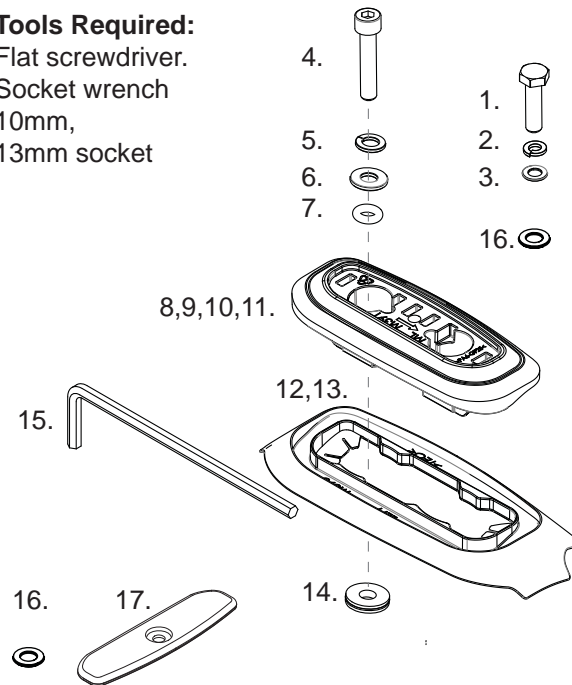

Instructions

1

Remove the roof trim covers with a flat blade screwdriver carefully. Remove all brackets, bolts and washers using a 13mm socket. Store the covers and attachment hardware for future use if needed.

NOTE: The existing bolts and washers are not used to fit the roof rack mounting pads.

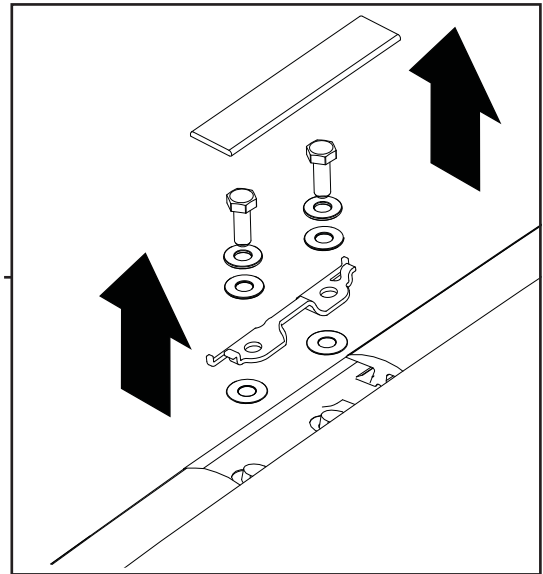
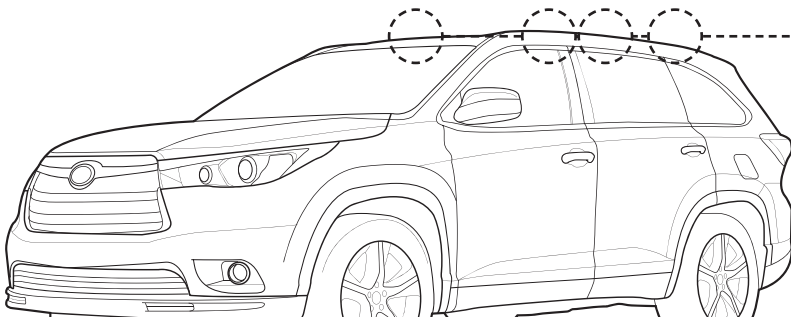

2

Place the foam covered mounting pad washers (item 18) over the plastic tubes in the roof channel. Make sure they are fitted neatly around the plastic tubes.

NOTE: Failure to fit the foam covered copper washers will result in water leaks.

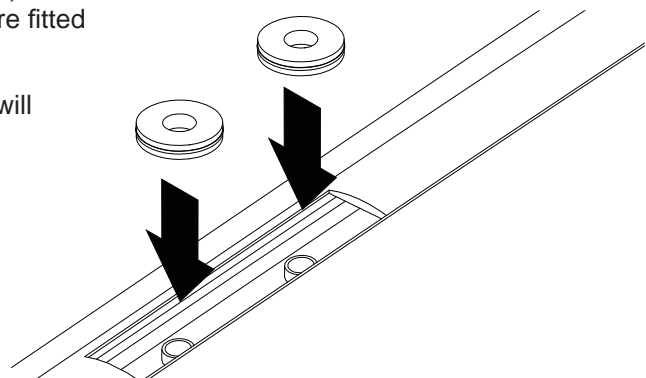
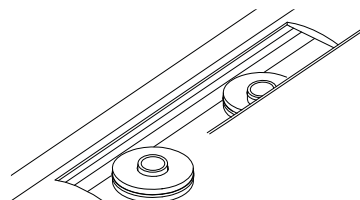



Toyota Kluger/Highlander SUV XU50 RCP37-BK

3

Match the appropriate rubber skirts (item 16 and 17) with the mounting pads

Item 16 - Left Pad Mount Skirt
FL = Front Left (M391)
RL = Rear Left (M393)

Item 17 - Left Pad Mount Skirt
FR = Middle Right (M392)
RR = Rear Right (M394)

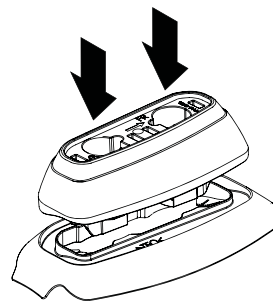

FRONT
(Top view of vehicle)

Arrows on top of parts must point towards FRONT of vehicle when correctly installed.

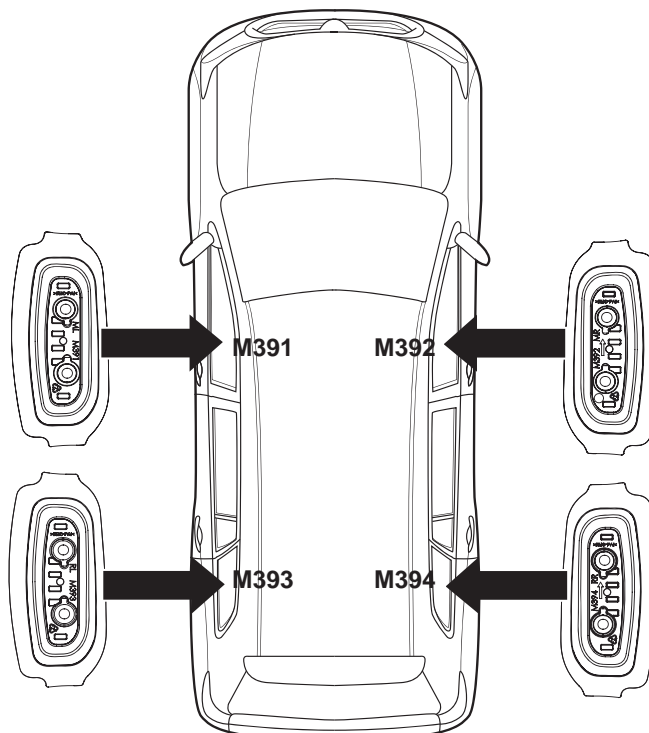
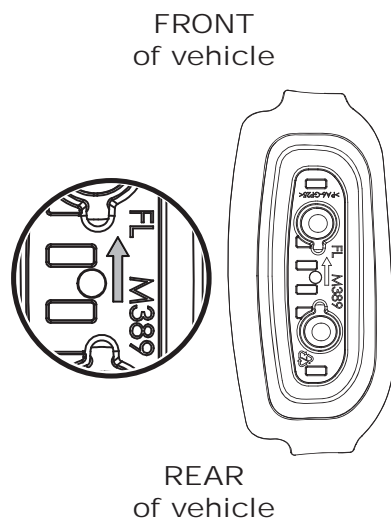

4

Place each pad into its position as stated in the previous step. Check to make sure the rubber skirt does NOT fold or twist when placed on the roof. It must flare out over surface of the roof.

Assemble M8 x 40mm bolt, washers and O-ring in the order shown. Push the O-ring up against the washers before locating into mounting pad. Finger tighten each pad first to ensure all parts are seated correctly.

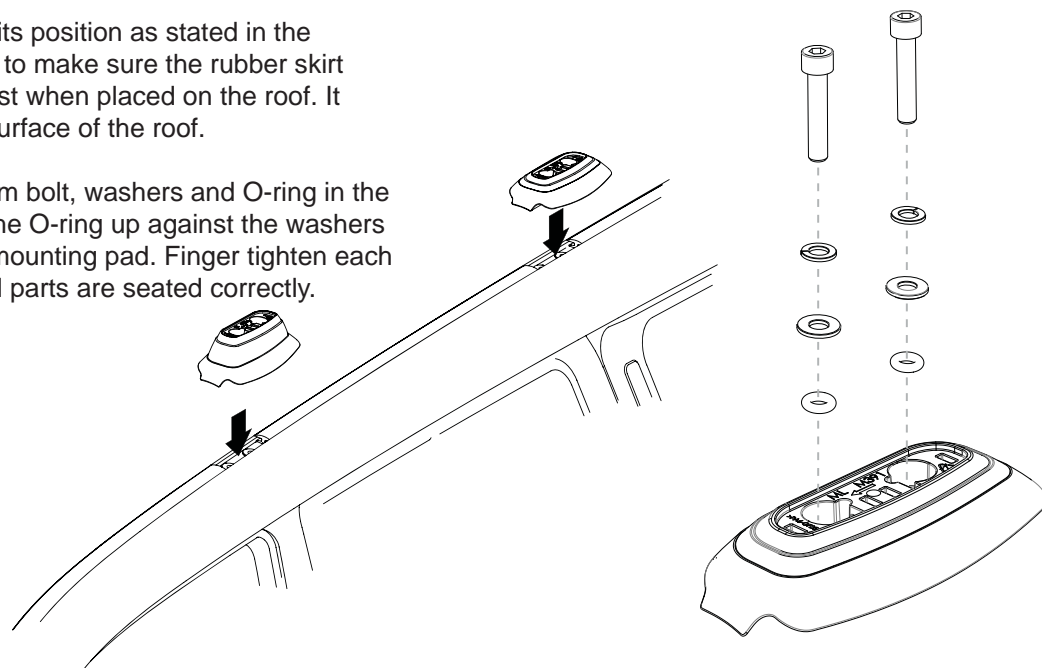



Toyota Kluger/Highlander SUV XU50 RCP37-BK

5

Tighten all M8 bolts using the 6mm allen key supplied.

Recommended tightening torque 9-11 Nm.
DO NOT OVER TIGHTEN.

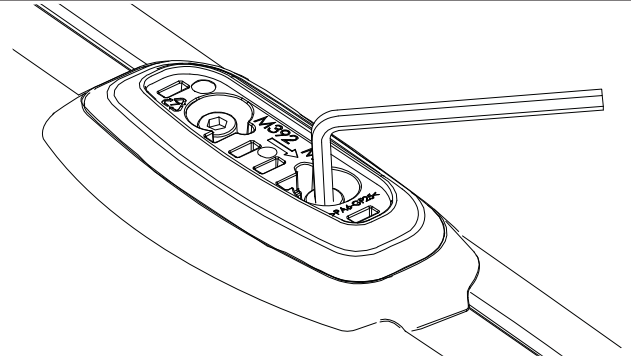

6

Fix the completed crossbars to the vehicle with an M6x30mm hex setscrew, M6 spring and 16mm flat washer (RVH shown as example only).

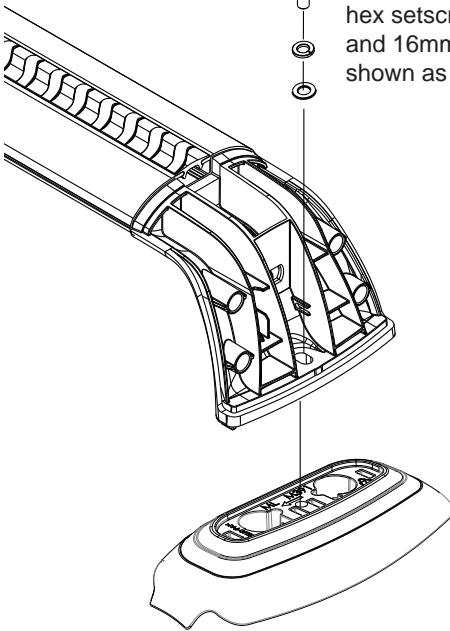

7

When crossbars are not in use, remove and install the cover plates as shown.

M6x30
Hex Set-
screw

M6 Spring
Washer

M6 x16mm
Flat
Washer

