

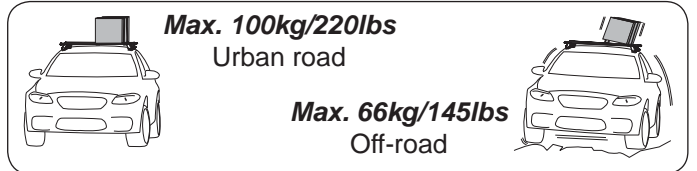

RHINO-RACK

SX009

WARNING!

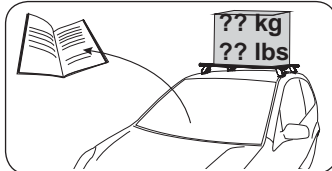
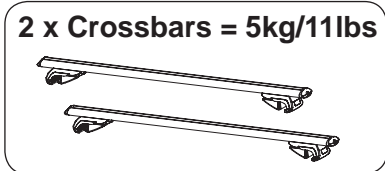
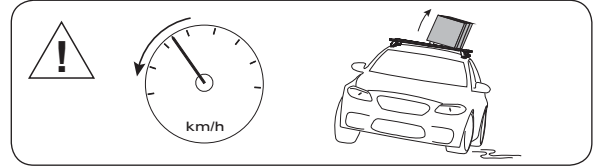
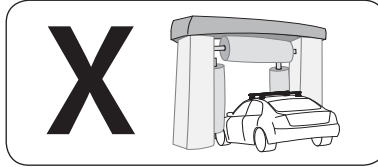
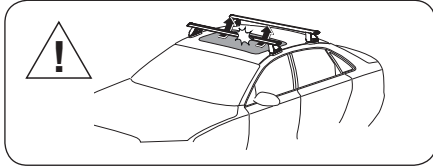
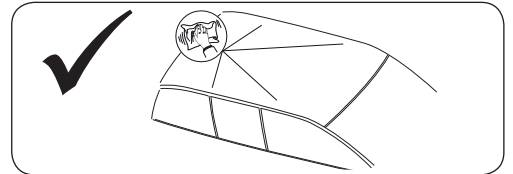
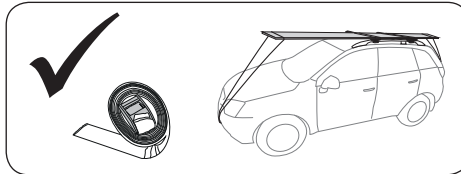
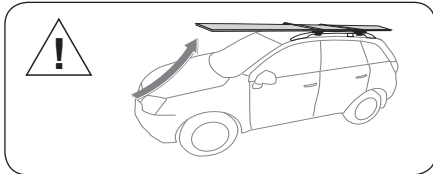

WARNING! Important Load Carrying Instructions

With utility vehicles, the cabin and the canopy move independently. [Roofracks](#) and vehicle can be damaged if the item transported is rigidly fixed at points on both the cabin and canopy. Instead, rigidly fix to either the cabin roofracks or the canopy roofracks.

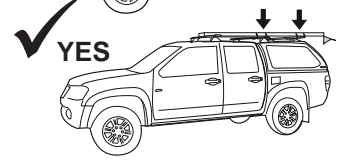
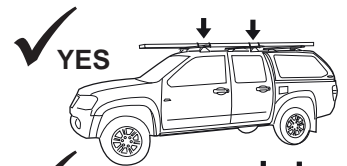
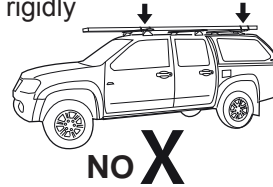

- Any load transported on Roof Racks must be evenly distributed.
- Instructions are to remain with the vehicle.
- Do not attempt to fit the roof racks to your vehicle unless you fully read and understand the fitting instructions provided.
- Please direct any questions to the dealer from where the roof racks were purchased.
- Check the contents of this kit before commencing fitment and report any discrepancies.

Maximum load capacity: 50kg/110lbs - 100kg/220lbs. Please refer to your vehicle manufacturers handbook for maximum roof load capacity, always use the lower of the two figures.

Recommendations:

It is essential that all bolt connections be checked after driving a short distance when you first install your crossbars. Bolt connections should be checked and lubricated at regular intervals (probably once a week is enough, depending on road conditions, usage, loads and distances travelled). You should also check the crossbars each time they are refitted. Make sure to fasten your load securely. Please ensure that all loads are evenly distributed and that the centre of gravity is kept as low as possible.

Crossbars must be removed when putting vehicle through an automatic car wash.

Use only non-stretch fastening ropes or straps.

Caution: The handling characteristics of the vehicle changes when you transport a load on the roof. For safety reasons we recommend you exercise extreme care when transporting wind-resistant loads. Special consideration must be taken into account when cornering and braking.

Off-road Load Rating:

When crossbars are to be used in off-road conditions, please build a safety factor of 1.5 into this load limit for off-road use, two crossbars = **33kg/73lbs - 66kg/145lbs**. Although the crossbars are tested and approved to AS1235-2000, off-road conditions can be much more rigorous. However, increasing the number of crossbars does not increase the vehicles maximum permissible roof loading.



SX009

Item	Component Name	Qty	Qty	Part No.
		SX009H	SX009	
1	Vortex Generating Strip	1-2	2-4	M626
2	Crossbar	1	2	VA---
3a	End Cap	2	4	M645
3b*	End Cap (locking)	2	4	VA-LEC4
4*	Lock Barrel Key	2	3	CA1069
5	Crossbar Under Bar Strip	2	4	M641
6	Outer Rail Clamp	2	4	M072
7	Dowel Nut Wedge	2	4	M027
8	Inner Clamp + Rubber Pad	2	4	M073
9	Inner Clamp + Metal Bracket	2	4	C866
10	Torque Security Key For SXB	1	1	TORKEY-SXB
11	Fitting Instructions	1	1	R001

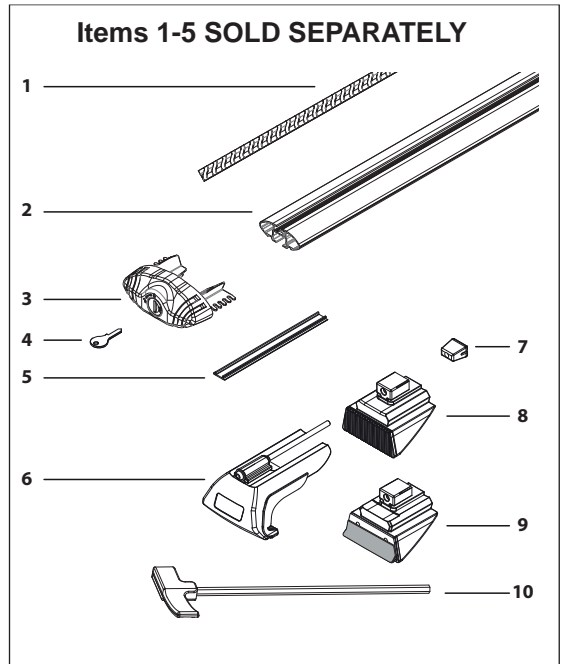

WARNING:

For Sorento with sunroof, assemble complete SXB leg with item no.8
 For Sorento without sunroof, assemble complete SXB leg with item no.9

Tools Required

Security key, included in kit.
 Side Cutters/Scissors.
 Tape Measure.

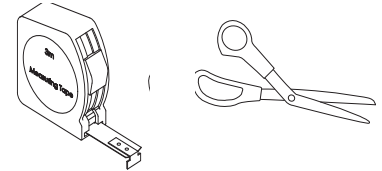

KIA Sorento with Sunroof

1a Assemble the rail clamp as shown

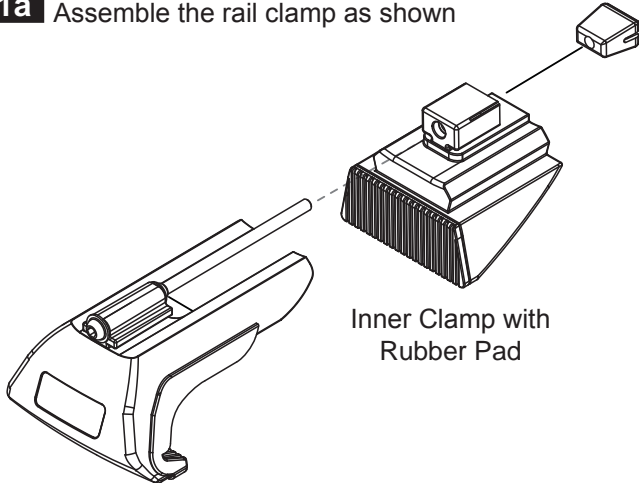

KIA Sorento without Sunroof

1b Assemble the rail clamp as shown

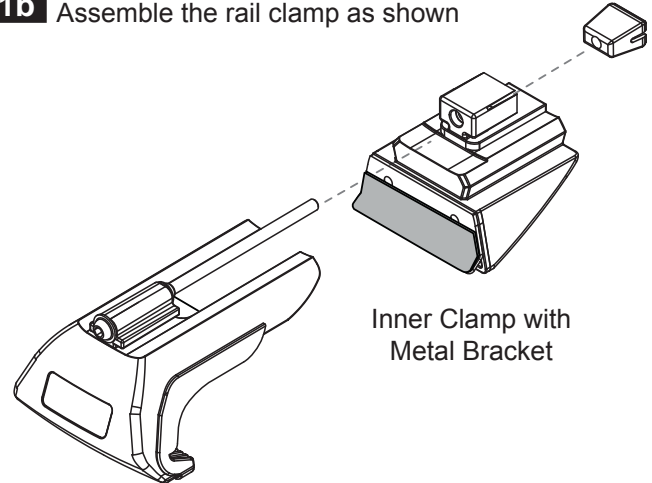

2a Slide the leg assembly into both ends of the crossbar.

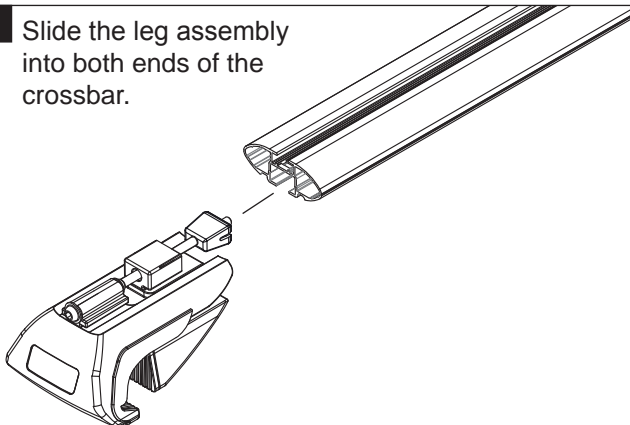

2b Slide the leg assembly into both ends of the crossbar.

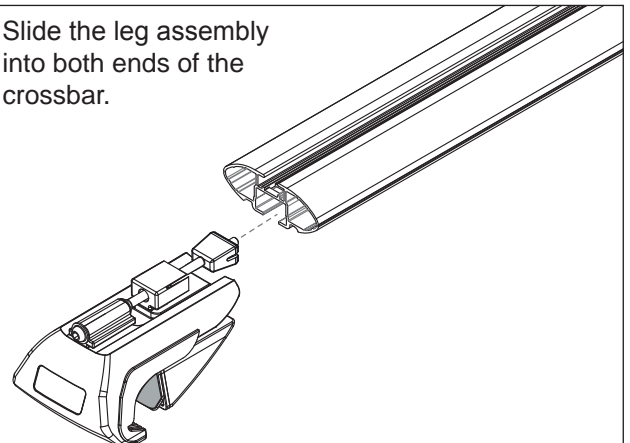



SX009

3a Insert the rubber buffer strip fully into the crossbar. Check the rubber buffer strip is fully inserted.

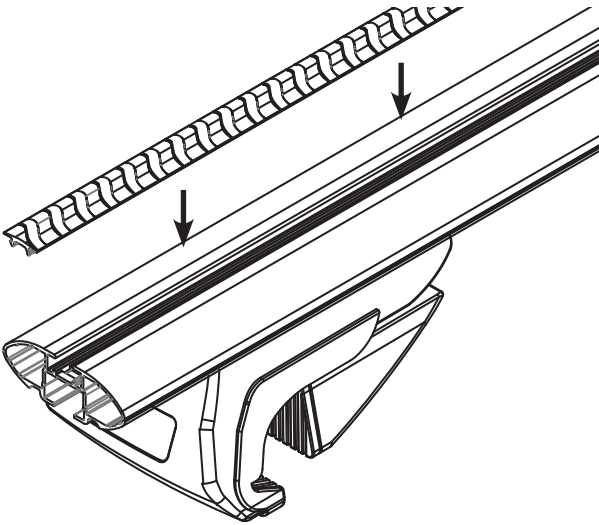

3b Insert the rubber buffer strip fully into the crossbar. Check the rubber buffer strip is fully inserted.

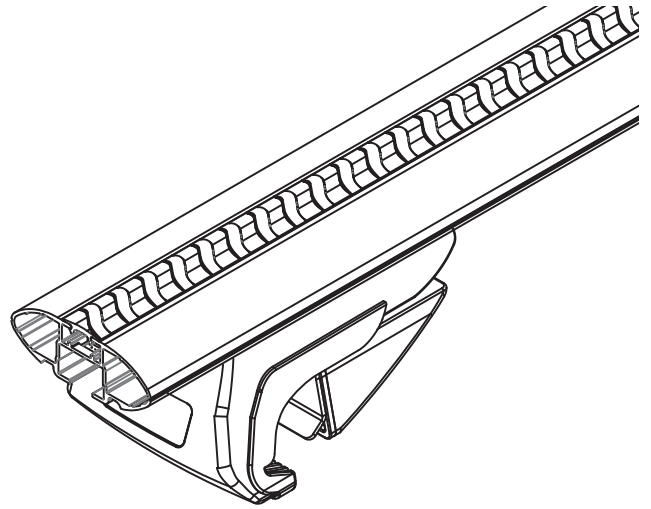

4a Place the roof rack over the rails so that the leg assembly locates on the top of the rails. Ensure that the crossbars are parallel across the vehicle.

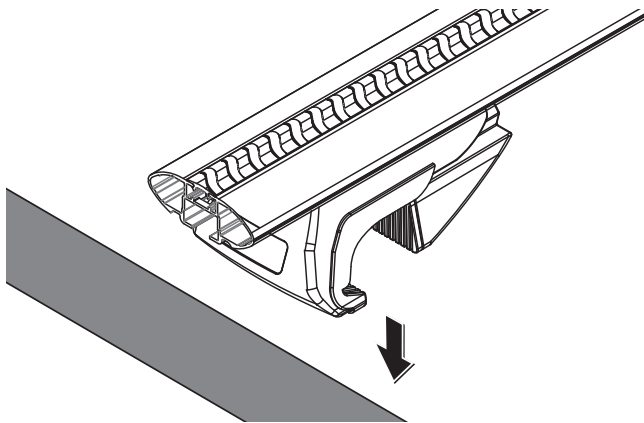

4b Place the roof rack over the rails so that the leg assembly locates on the top of the rails. Ensure that the crossbars are parallel across the vehicle.

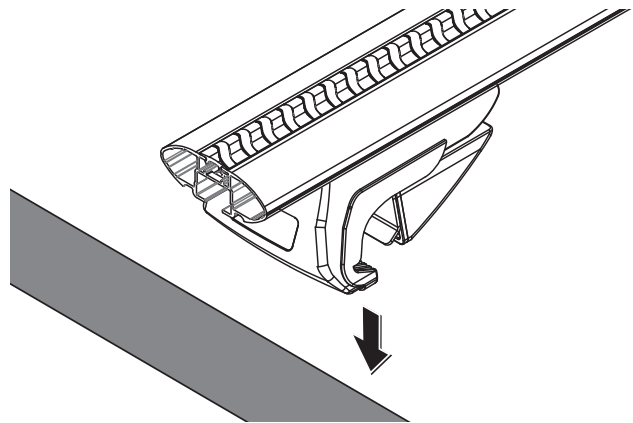

5 Place assembled roof racks onto the roof rails then pull the inner and outer leg clamp together to grip the rails.

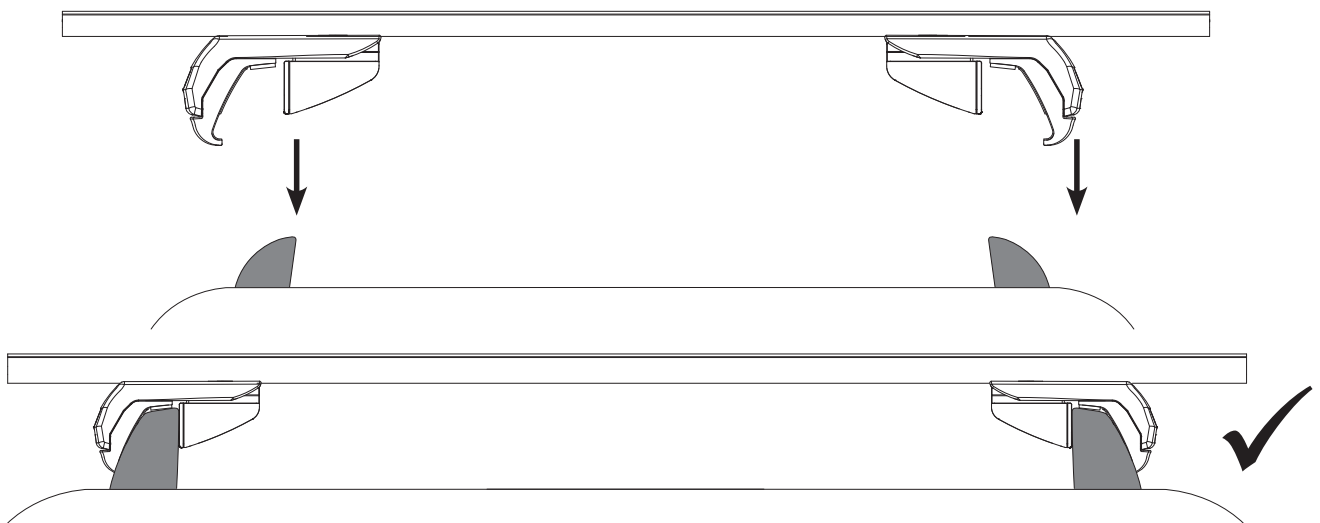



SX009

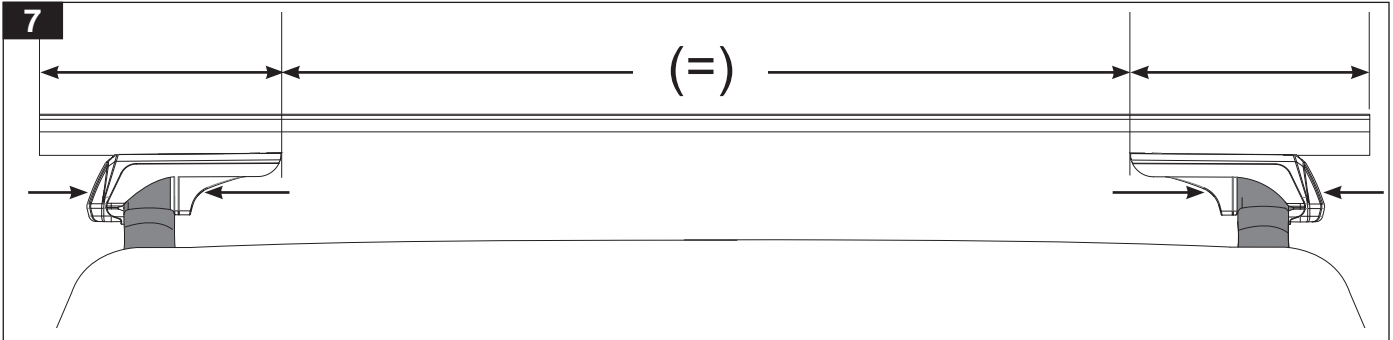
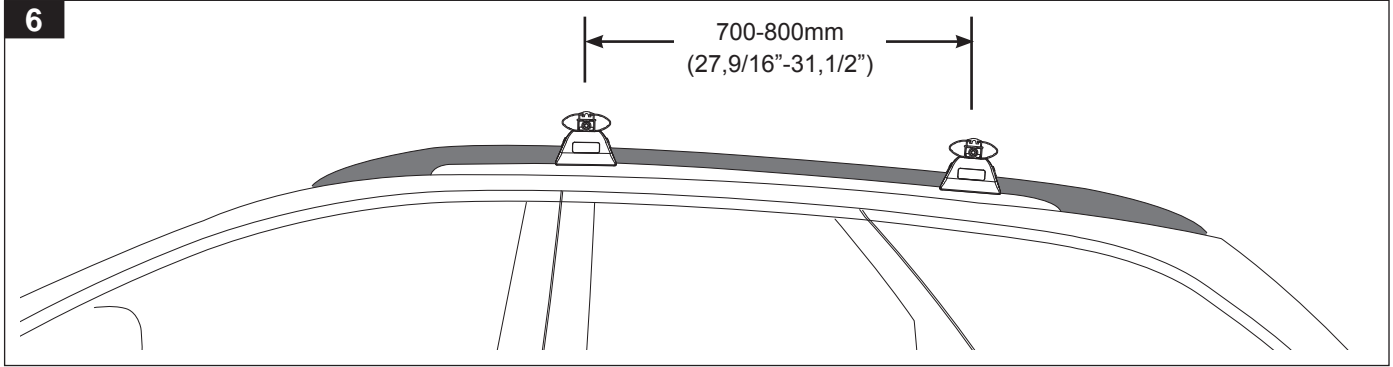

8 Using the allen key provided, engage the centre clamp bolt and screw the outer clamp leg in towards the inner leg. **Do not fully tighten the bolt** as final tightening occurs later.

Item 7
4-5 Nm
(2-3 lb/ft)

As pressure is applied, gasket will flare out creating a seal.

With Torque Key inserted (Item 7), turn clockwise until handle straightens out as shown above. This indicates 4-5 Nm. More pressure may be required in extreme climates.

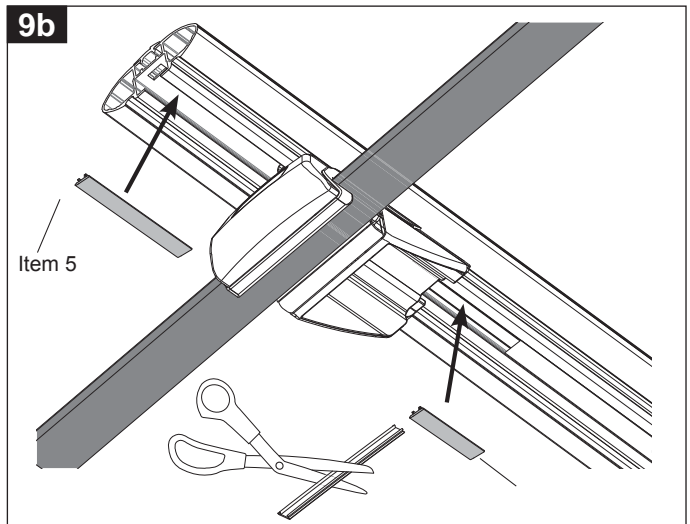
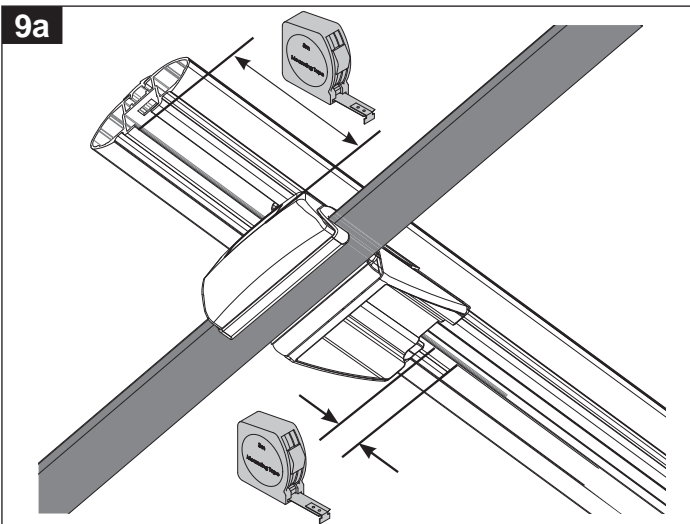



SX009

10a Insert End Cap (Item 3) as shown.

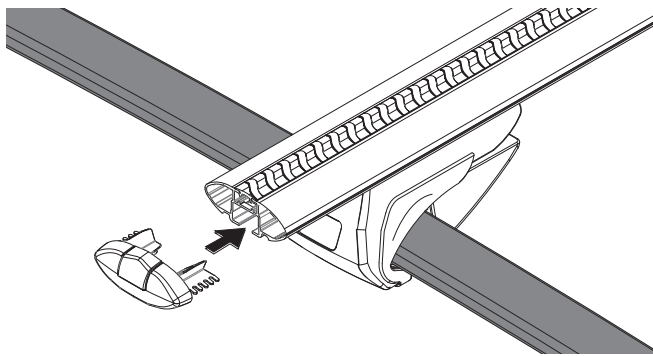

10b NOTE: 3b is an optional extra.

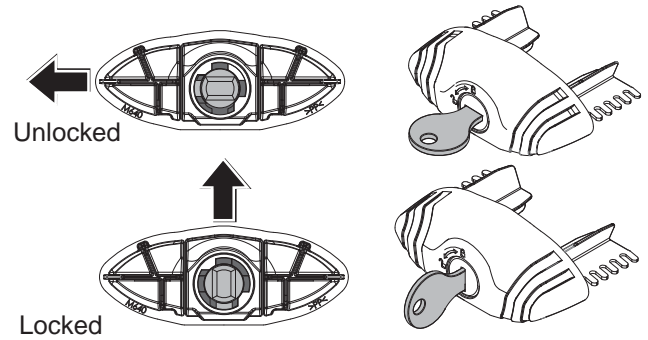

11

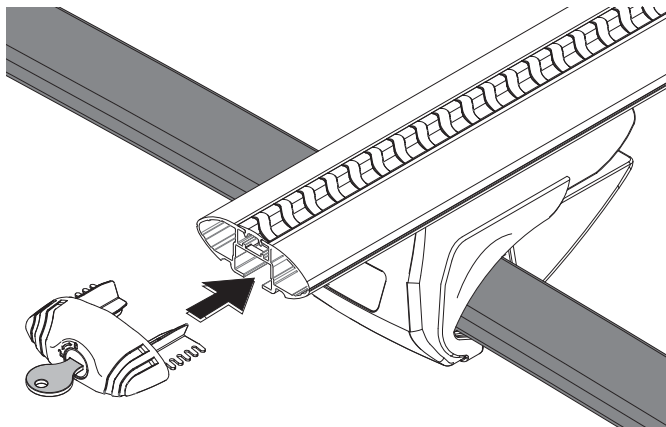

Insert End Cap and remove key

12

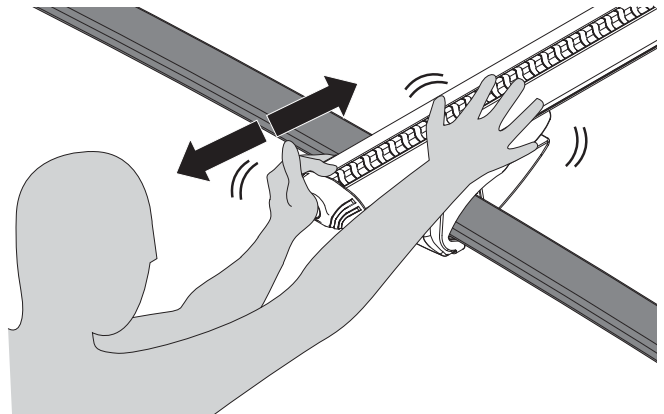

Test racks are secure

13 The roof bar system is ready to be used

