

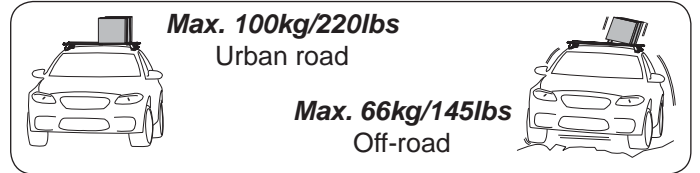

RHINO-RACK

SX022

WARNING!

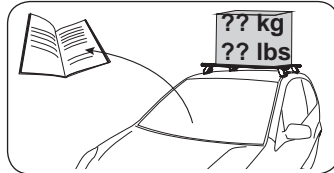
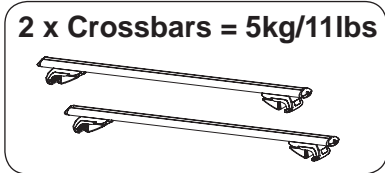
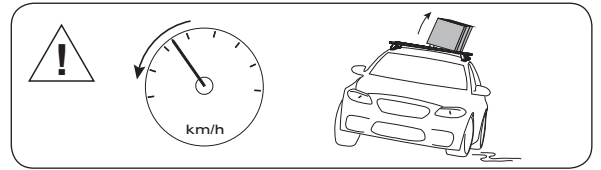
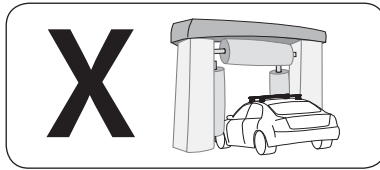
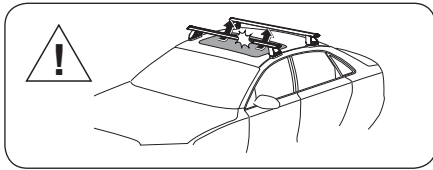
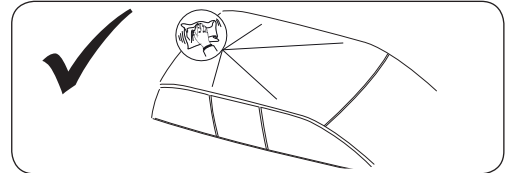
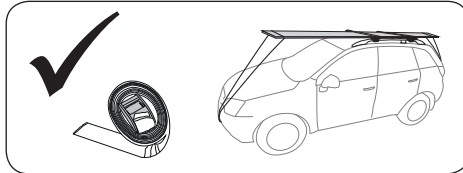
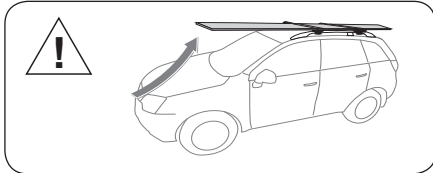

WARNING! Important Load Carrying Instructions

With utility vehicles, the cabin and the canopy move independently. [Roof racks](#) and vehicle can be damaged if the item transported is rigidly fixed at points on both the cabin and canopy. Instead, rigidly fix to either the cabin roof racks or the canopy roof racks.

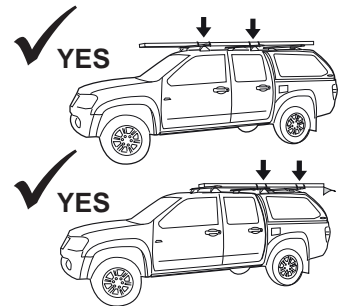
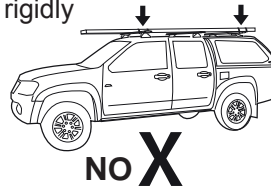

- Any load transported on Roof Racks must be evenly distributed.
- Instructions are to remain with the vehicle.
- Do not attempt to fit the roof racks to your vehicle unless you fully read and understand the fitting instructions provided.
- Please direct any questions to the dealer from where the roof racks were purchased.
- Check the contents of this kit before commencing fitment and report any discrepancies.

Maximum load capacity: 50kg/110lbs - 100kg/220lbs. Please refer to your vehicle manufacturers handbook for maximum roof load capacity, always use the lower of the two figures.

Recommendations:

It is essential that all bolt connections be checked after driving a short distance when you first install your crossbars. Bolt connections should be checked and lubricated at regular intervals (probably once a week is enough, depending on road conditions, usage, loads and distances travelled). You should also check the crossbars each time they are refitted. Make sure to fasten your load securely. Please ensure that all loads are evenly distributed and that the centre of gravity is kept as low as possible.

Crossbars must be removed when putting vehicle through an automatic car wash.

Use only non-stretch fastening ropes or straps.

Caution: The handling characteristics of the vehicle changes when you transport a load on the roof. For safety reasons we recommend you exercise extreme care when transporting wind-resistant loads. Special consideration must be taken into account when cornering and braking.

Off-road Load Rating:

When crossbars are to be used in off-road conditions, please build a safety factor of 1.5 into this load limit for off-road use, two crossbars = **33kg/73lbs - 66kg/145lbs**. Although the crossbars are tested and approved to AS1235-2000, off-road conditions can be much more rigorous. However, increasing the number of crossbars does not increase the vehicles maximum permissible roof loading.



SX022

Item	Component Name	Qty	Qty	Part No.
		SX022H	SX022	
1	Vortex Generating Strip	1-2	2-4	M626
2	Crossbar	1	2	VA---
3a	End Cap	2	4	M645
3b*	End Cap (locking)	2	4	VA-LEC4
4*	Lock Barrel Key	2	3	CA1069
5	Crossbar Under Bar Strip	2	4	M641
6	SX Leg	2	4	SUB0508
7	Torque Security Key For SXB	1	1	TORKEY-L
8	Fitting Instructions	1	1	R280

Parts List Items 1-5 SOLD SEPARATELY

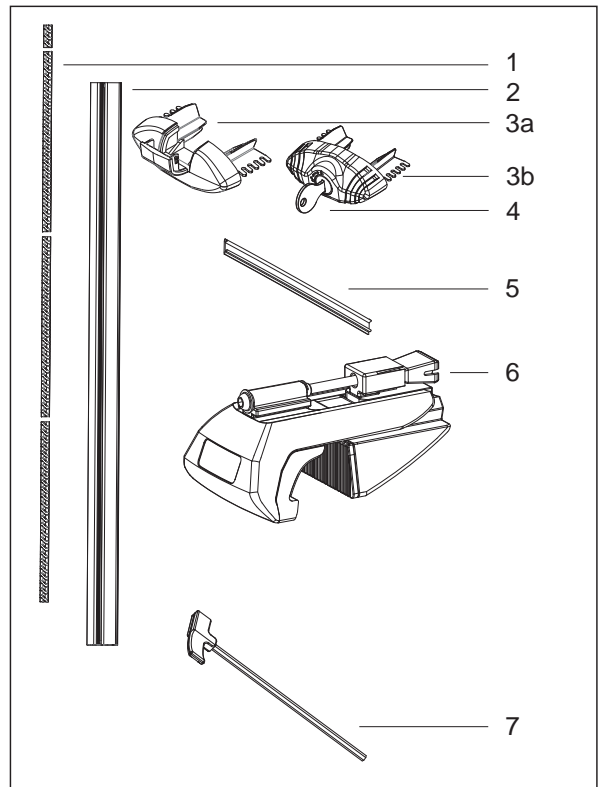

*Optional Extra

Tools:

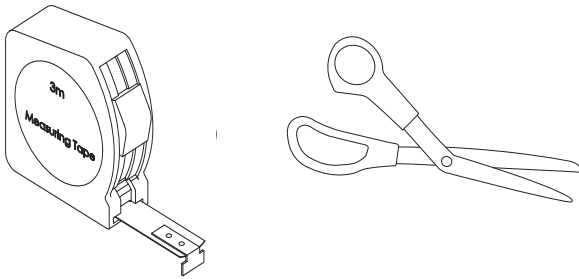

1

Item 1

Item 2

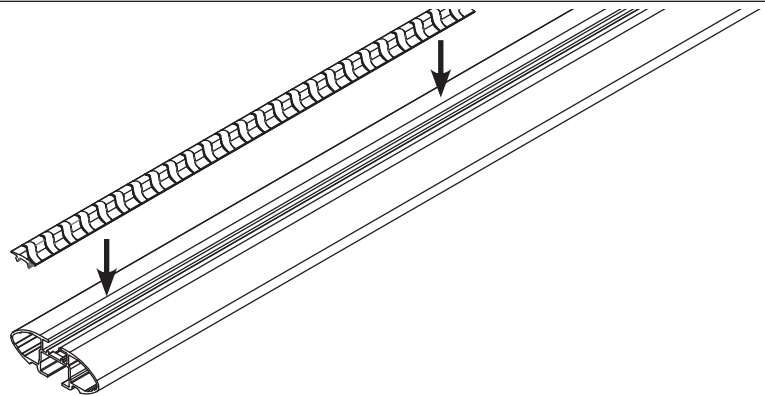

2

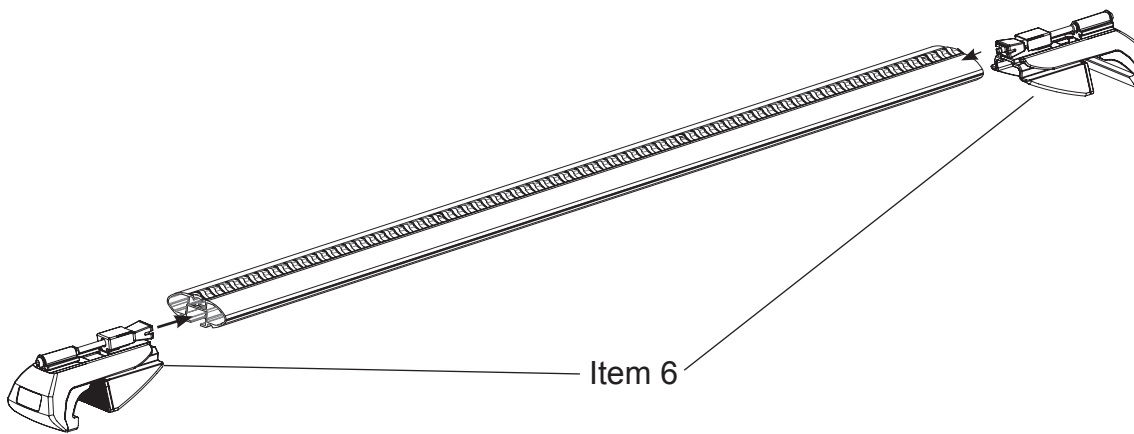



SX022

3 NOTE: Fitting instructions here shown with the SX100 legs.



4 700-800mm
(27,9/16"-31,1/2")

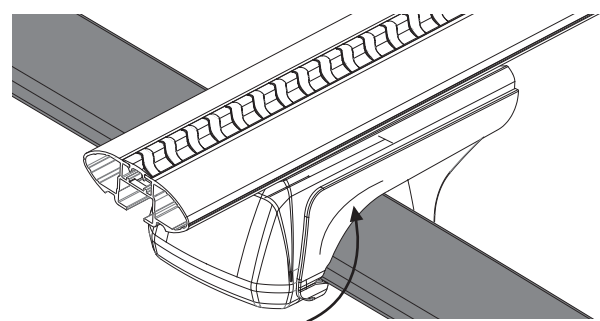
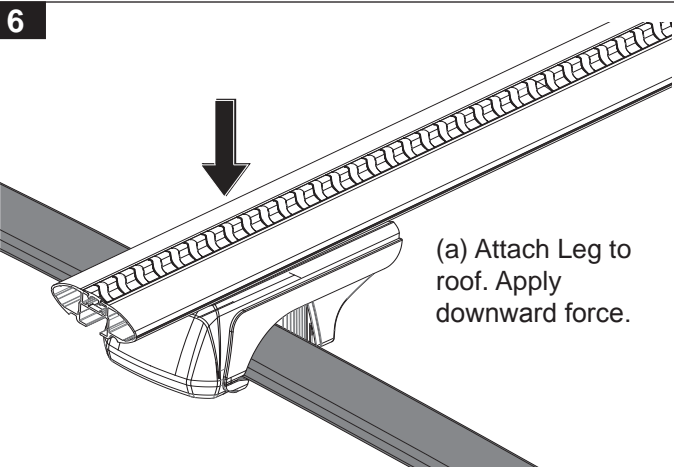
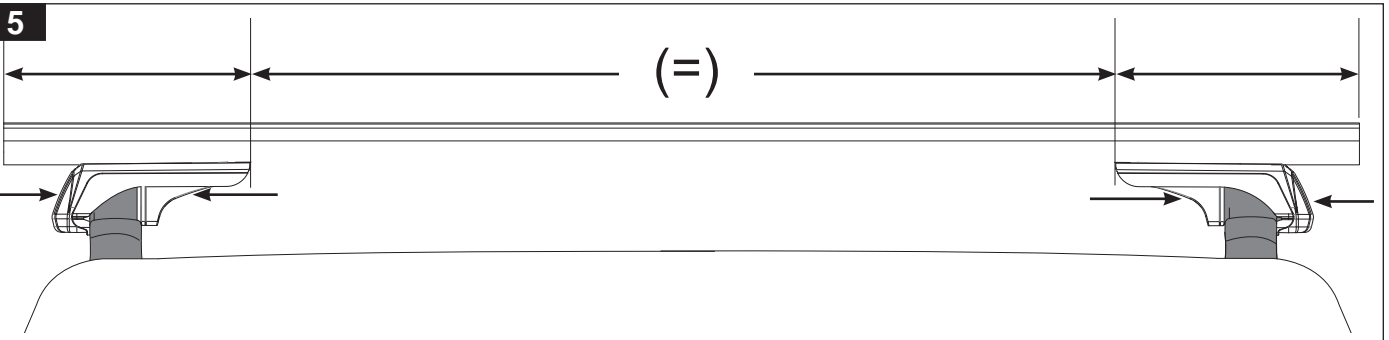
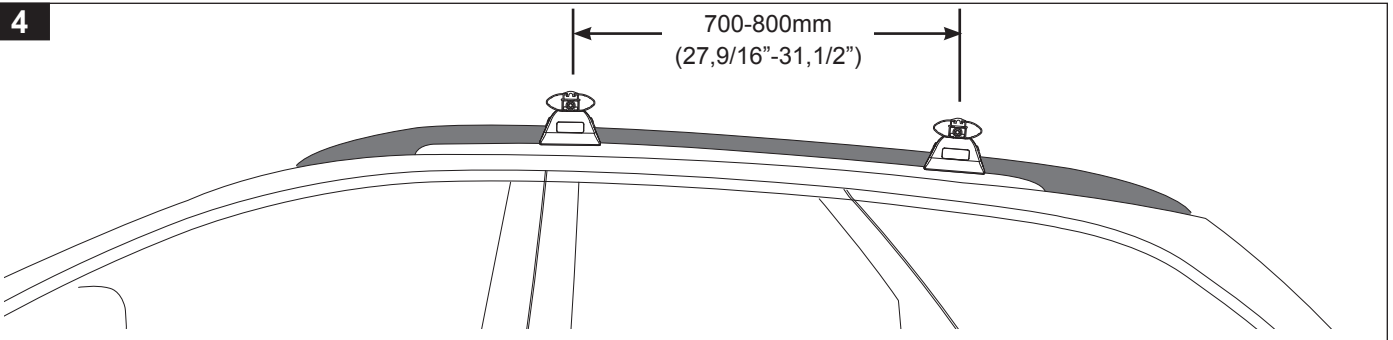

Check gasket is flared out and not tucked under prior to tightening. **Note:** The gasket will create a seal with the roof rail when pressure is applied.



SX022

7a

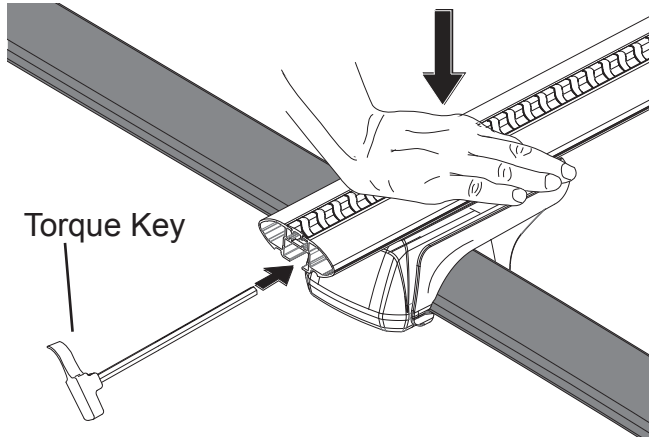

Torque Key

Fasten each leg alternately using the supplied Torque allen key.

7b

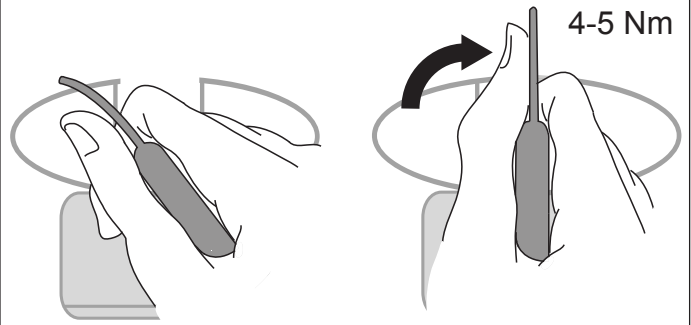

4-5 Nm

With Torque Key inserted, turn clockwise until handle straightens out as shown above. This indicates 4-5 Nm. More pressure may be required in extreme climates.

8a

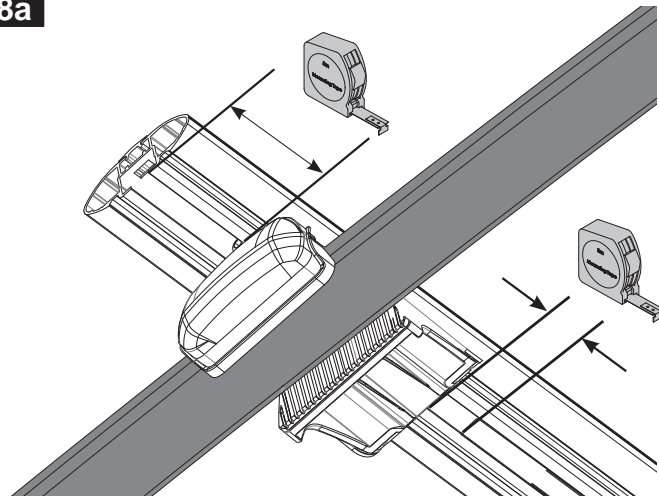

8b

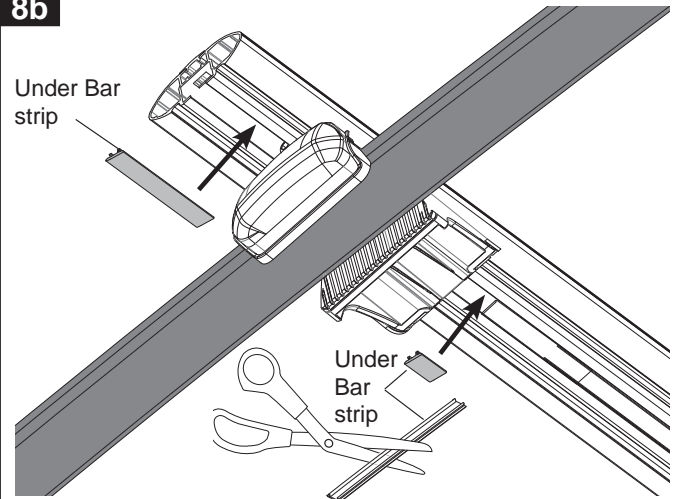

Under Bar strip

Under Bar strip

9a Insert End Cap as shown.

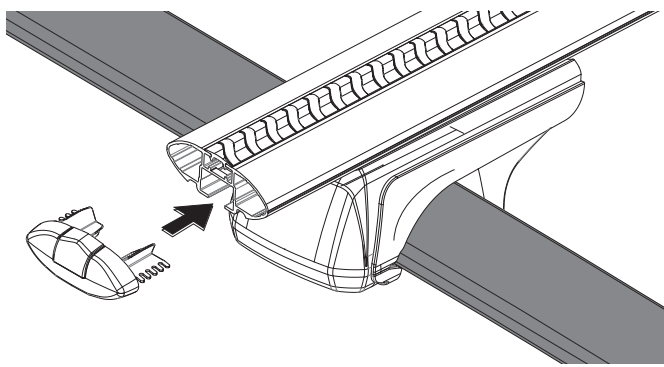

9b NOTE: Locking End Cap is an optional extra.

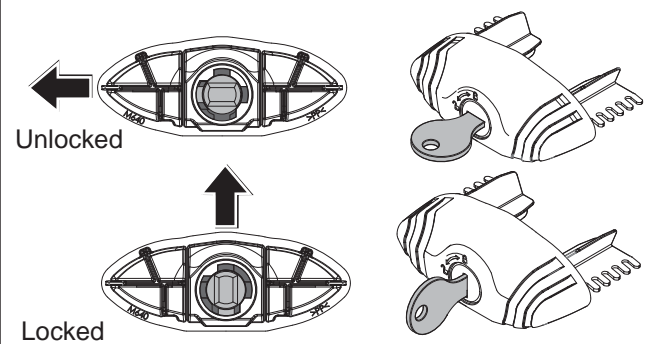

Unlocked

Locked

10

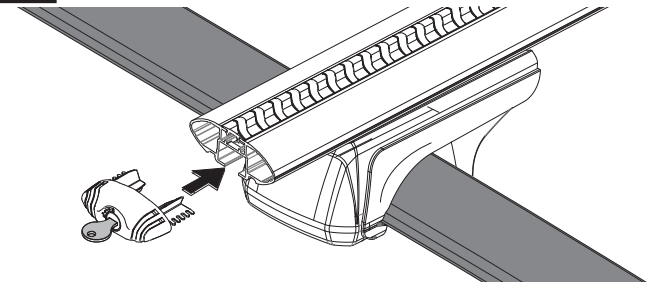

Insert Locking End Cap and remove key

11

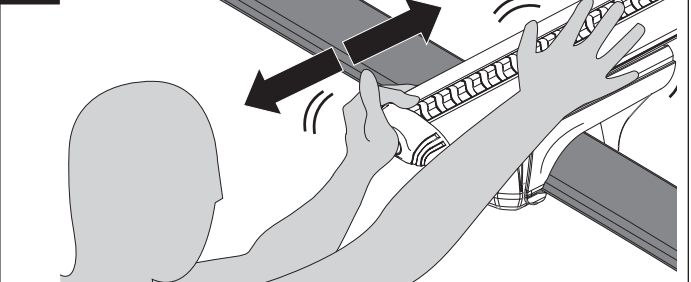

Test racks are secure