



METAL FRAME CAR SHELTER

12' x 20' x 8'

SC122008JJ

ASSEMBLY & OPERATING INSTRUCTIONS

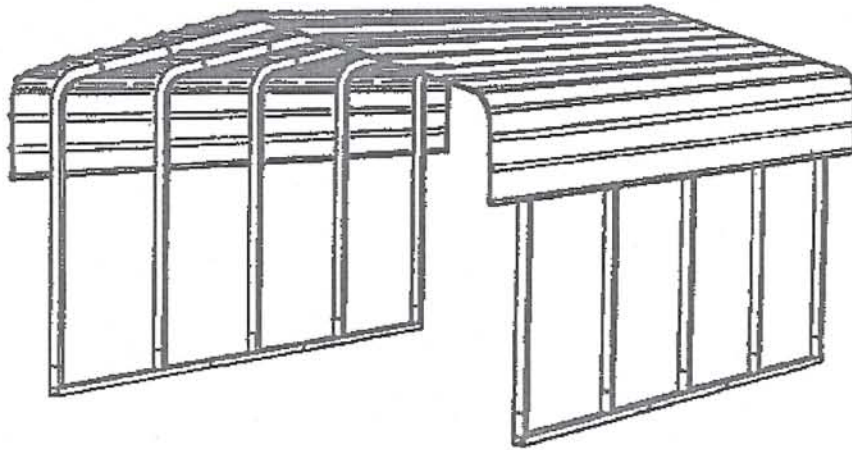

Due to continuing improvement, actual product may differ slightly from product described herein.

Due to continuing improvements, actual product may differ slightly from the product described herein.



PRODUCT SPECIFICATIONS

Item	Description
Overall Dimensions	20' Long x 12' Wide x 8' High
Roof Panel Dimensions	10' Long x 3' Wide x 28 Gauge T
Roof Overhand	11" Out from Frame
Roof Gables	16" From Center of Peak Down
Frame Dimensions	External: 18'1/4" Long x 12'3-7/8" Wide x 8'3-3/4" High @ Center Internal: 18'1-1/4" Long x 12'1-3/16" Wide x 8'1-3/4" High
Side Wall Height	6'8" High
Side Post Spacing	4'6" On Centers
Tubing	2" x 2" Square Tubing
Anchor Stake Size	30" Long x 1/2" O.D.
Weight	Approximately 600 Pounds

SAVE THIS MANUAL

You will need this manual for the safety warnings and precautions, assembly, operating, inspection, maintenance and cleaning procedures, parts list and assembly diagram. Keep your invoice with this manual. Write the invoice number on the inside of the front cover. Keep this manual and invoice in a safe and dry place for future reference.

GENERAL SAFETY RULES

IMPORTANT SAFETY INSTRUCTIONS





WARNING!

READ AND UNDERSTAND ALL INSTRUCTIONS

Failure to follow all instructions detailed in this manual may result in serious personal injury.

SAVE THESE INSTRUCTIONS

1. **Keep your work area clean and well lit.** Cluttered and dark work areas invite accidents.
2. **Stay alert.** Watch what you are doing, and use common sense when operating tools and equipment. Do not assemble this product while tired or under the influence of drugs, alcohol, or medication. A moment of inattention while operating tools and equipment may result in serious personal injury.
3.  **Wear eye protection.** Wear ANSI-approved safety impact goggles when assembling this product. The factory machined metal parts may be extremely sharp. Handle with caution and wear heavy duty work gloves.  Also, wear an ANSI-approved hard hat and steel toe boots for additional protection.

4. **Do not force the Car Shelter.** Use the correct product for your application. The correct product will do the job better and safer at the rate for which it is designed.
5. **Maintain the Car Shelter with care.** Keep this product clean. Properly maintained products are less likely to malfunction. Do not use damaged products. Tag damaged products **“Do not use”** until repaired.
6. **Check for any condition that may negatively affect the Car Shelter’s operation.** If damaged, have the Car Shelter serviced before using. Many accidents are caused by poorly maintained products.
7. **Use only accessories that are recommended by the manufacturer for your model.** Accessories that may be suitable for one product may become hazardous when used on another product.
8. **Industrial applications must follow OSHA requirements.**
9. **Maintain labels and nameplates on the Car Shelter.** These carry important information. If unreadable or missing, contact MDM Products for a replacement.
10. **Use the right product for the job.** There are certain applications for which this product was designed. Do not use small products to do the work of larger industrial products. Do not use this product for a purpose for which it was not intended.
11. **Product service must be performed only by qualified service technician.** Service or maintenance performed by unqualified personnel could result in a risk of injury.
12. **When servicing the Car Shelter, use only identical replacement parts.** Follow instructions in the “Inspection, Maintenance, And Cleaning” section of this manual. Use of unauthorized parts or failure to follow maintenance instructions may create a risk of personal injury.
13. **Always make sure the area of use for this product is clear of any children and pets.** Do not allow children to play on or in the Car Shelter.
14. **Do not attempt to assemble the Car Shelter when high wind conditions exist as personal injury and/or property damage may result.**
15. **Whether assembling on a concrete foundation using cement anchor bolts (not included) or using the Anchor Stakes (provided) to secure to the ground, make sure the Car Shelter is secured to a flat, dry and level surface.**

16. **Do not allow snow to accumulate on the Car Shelter as the canopy could collapse.** The Car Shelter could topple in strong winds, causing damage to personal property. Disassemble if weather conditions become severe and could damage the Car Shelter. Clear heavy debris off the shelter before going under it. MDM Products is not responsible for damage due to weather conditions and will not be held responsible for a Car Shelter exposed to and/or damaged by conditions such as high winds, heavy rain, snow or ice under any conditions.
17. **Do not attempt to move an assembled Car Shelter.**
18. **Do not sit or stand on top of the Car Shelter, and do not place anything on top of the Car Shelter.**
19. **Snow/debris accumulation hazard.** The heavy weight of accumulated snow or other debris can cause parts of this Car Shelter to buckle suddenly. Do not allow debris to accumulate on top of the Car Shelter. If snowfall is expected, place additional supports (not provided) underneath the roof. NEVER enter a Car Shelter with accumulated debris on top
20. **WARNING!** Ladders are inherently dangerous equipment to use. If you are using a ladder to assemble this product, make sure to read and adhere to the safety warnings and instructions as recommended by the manufacturer/distributor of the ladder you are using.
21. **Prolonged exposure to wind can cause fasteners and hardware to loosen as the frame flexes.** The Car Shelter's frame strength will be compromised if fasteners and hardware are not tight. Periodically, check to make sure all fasteners and hardware are tight. Tubes and Anchors should also be periodically checked to make sure the unit is always structurally rigid.
22. **WARNING! Do not allow the vehicle's engine to run while parked within the Car Shelter.** When running, the engine of a vehicle produces carbon monoxide, a colorless, odorless, toxic gas that, when inhaled, can cause serious personal injury or death.
23. **WARNING!** The warnings and cautions discussed in this manual cannot cover all possible conditions and situations that may occur. It must be understood by the operator that common sense and caution are factors which cannot be built into this product, but must be supplied by the operator.

SAVE THESE INSTRUCTIONS

UNPACKING

When unpacking, check to make sure all the parts shown in the **Parts List on page 12** are included. If any parts are missing or broken, please call MDM Products at the number shown on the front cover of this manual as soon as possible.

FOUNDATION

IMPORTANT - READ THE FOLLOWING CAREFULLY BEFORE PROCEEDING



Prior to assembly, a proper foundation must be laid. The Car Shelter must be properly supported to help prevent property damage and injury in the event of strong winds or inclement weather. Wind and ground conditions may vary from site to site, and may affect the practicality and effectiveness of anchoring methods substantially. If you have any doubt regarding the stability of the foundation you are to use, consult a professional.

It is always your responsibility to ensure that the Car Shelter is properly anchored. MDM Products cannot be held responsible for personal injury, damage to the Car Shelter, or other property damage that occurs as a result of improperly anchoring the Car Shelter.

Be certain to check with local authorities to obtain all required building permits and to familiarize yourself with any building codes that may apply.

Decide on a location for the Car Shelter. The location should optimally be a level, well-lit area that is sheltered from the wind. The entrance of the Car Shelter should not open towards the prevailing wind, if possible.

ASSEMBLY INSTRUCTIONS

-  **Wear eye protection.** Wear ANSI-approved safety impact goggles when assembling this product. The factory machined metal parts may be extremely sharp. Handle with caution, and wear heavy duty work gloves.
 Also, wear an ANSI-approved hard hat and steel toe boots for additional protection.
-  **WARNING!** Ladders are inherently dangerous equipment to use. If you are using a ladder to assemble this product, make sure to read and adhere to the safety warnings and instructions as recommended by the manufacturer/distributor of the ladder you are using.
- NOTE: More than one person is required to assemble this product.**

Ground Installation (“Caisson”)

1. When installing the Car Shelter to the ground, dig a post hole 12” in diameter and 24” deep. Dig ten holes of similar depths, using the four End Base Rails (5) and two Center Base Rails (6) as guides for where the holes should be dug.
2. Use a post hole digger or auger (not included) to drill your 30” deep holes into the ground. Clean out the holes. Lay out the base rails and fit the Anchor Stakes (7) into the pre-dilled holes in the rails and then into the drilled holes in the ground. Using a shovel (not included), fill the holes with 2500psi-rated concrete (not included.)
3. You should wait at least seven days for the concrete to properly set in the holes before continuing with the Car Shelter assembly.

Site Preparation For Concrete Foundation

1. It is recommended the Car Shelter be placed on a concrete foundation that is level side to side and sloped about 1/8” per foot from front to back or back to front to allow for proper drainage. **DO NOT USE THE ANCHOR STAKES (7) TO SECURE THE CAR SHELTER TO A CONCRETE BASE.**
2. If you will be pouring a concrete slab for your Car Shelter, the slab should be at least 5” thick and the concrete 2,500 to 3,000 PSI. **NOTE:** Make sure the slab is completely dry before installation.
3. The outside dimensions of the concrete slab should be at least 3” larger than the outside frame dimensions of the Car Shelter. Example: If the outside frame dimensions of the Car Shelter is **18’1/4” long and 12’3-7/8” wide** the concrete slab dimensions should be **18’3-1/4” long and 12’6-7/8” wide**. This will allow the Anchor Bolts (10) to be 3” from the edge of the slab. **(See Figure A.)**

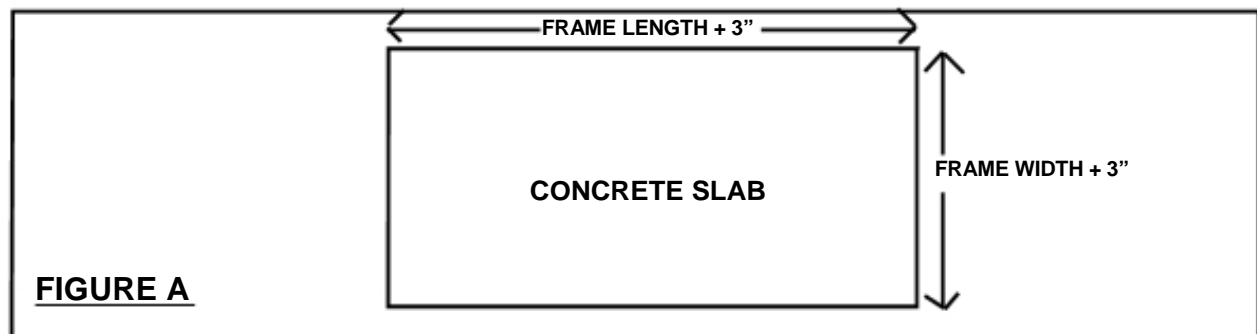

Assembling And Positioning The End Base And Center Base Rails:

1. Lay out the four End Base Rails (5) and two Center Base Rails (6) on the concrete slab. **(See Figure B, next page.)**

2. Join the End Bases (5) and Center Bases (6) together.
(See Figure B.)
3. Using a tape measure (not included), take a measurement across the diagonals of the frame to check it for squareness. Adjust the frame until the measurements are equal.
(See Figure B.)

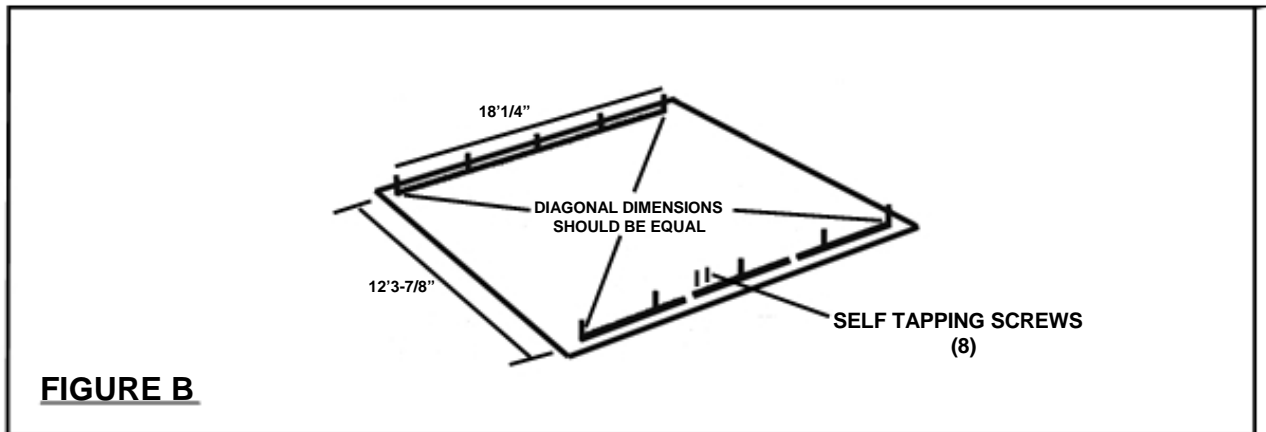

4. After you have completed all measurements and have the End Base (5) and Center Base (6) Rails in place and squared, screw the joints together with two Self Tapping Screws (8) per joint on the top surface of the Base Rails.
(See Figure B.)

Anchoring The End Bases And Center Bases To The Concrete Slab:

1. To drill the anchor holes, you will need a hammer drill and a 1/2" diameter concrete drill bit (neither included).
2. Hold the Base Rails (5, 6) in place with your foot. Insert the 1/2" diameter concrete drill bit through the anchor holes in the Base Rails and drill the holes about 5" deep into the concrete slab. **(See Figure C.)**

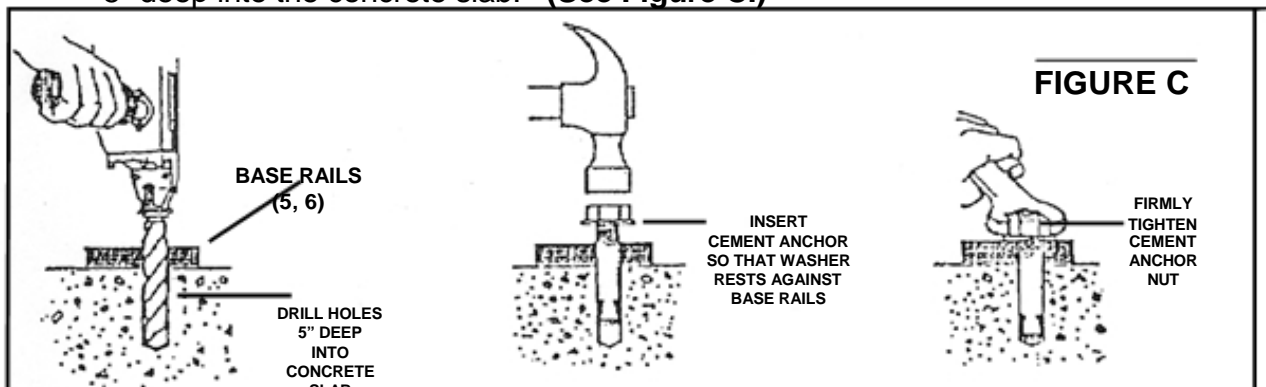

3. Once the holes are drilled, use an air compressor to blow out the concrete dust with compressed air from each of the holes. **WARNING:** To avoid inhaling dust particles, wear a protective mask or face shield. **(See Figure C.)**
4. Use a hammer to tap the cement anchors (not included) through the pre-drilled holes into the concrete slab surface. Continue tapping the cement anchors until their washers rest against the top edge of the Base Rails (5, 6). **(See Figure C.)**
5. Firmly tighten the nuts of the cement anchors (not included) to secure the Base Rails (5, 6) to the concrete slab surface. **(See Figure C.)**
6. When securing to the ground, use the Anchor Stakes (7) in place of the cement anchors. **Please Note:** Before set up, be sure that the ground where the Stakes are installed is free of any underground pipes or wires.

Roof And Wall Assembly:

1. Before assembling the roof and wall sections, stack the Peak Tubes (2). Line up their ends and mark a line on the top of each Peak Tube 17-1/8" from one end. This will be the location of the edge of your first run of sheet metal Panels (1) on the roof of the Car Shelter. **(See Figure D.)**

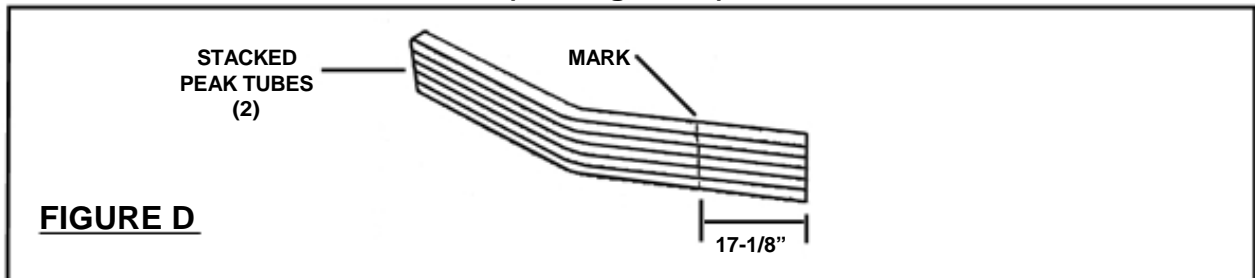

2. On the ground, assemble the Peak Tubes (2), Rafters (3), and Side Posts (4) using the Self Tapping Screws (8). **(See Figure E.)**

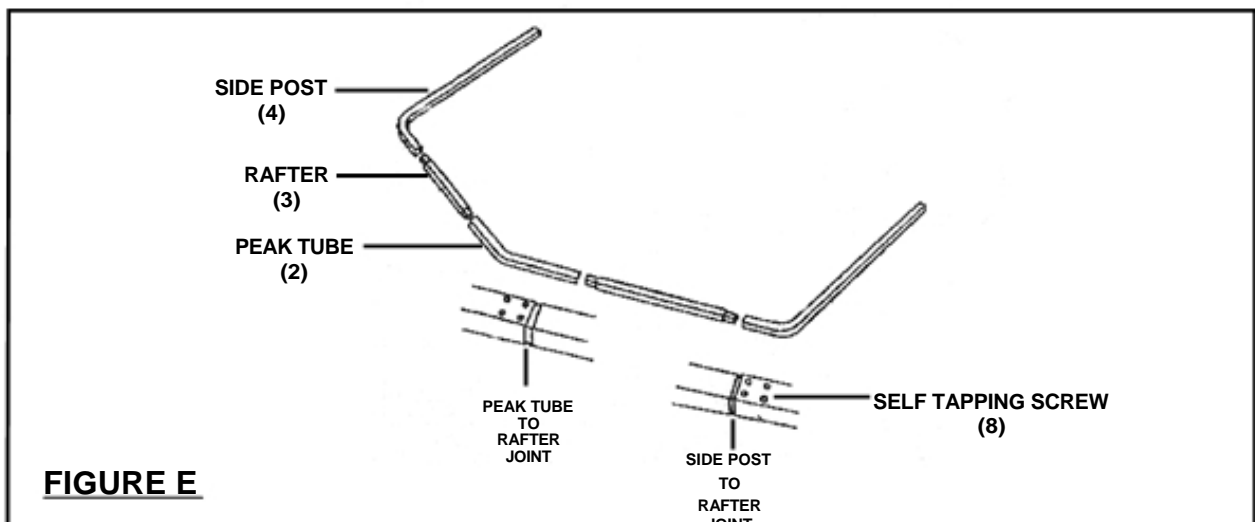

- Place the bottom of the Side Posts (4) on the Base Rail (5, 6) pins and drop the Side Posts onto the pins. Then secure the Side Posts to the pins, using the Self Tapping Screws (8). **(See Figure F.)**

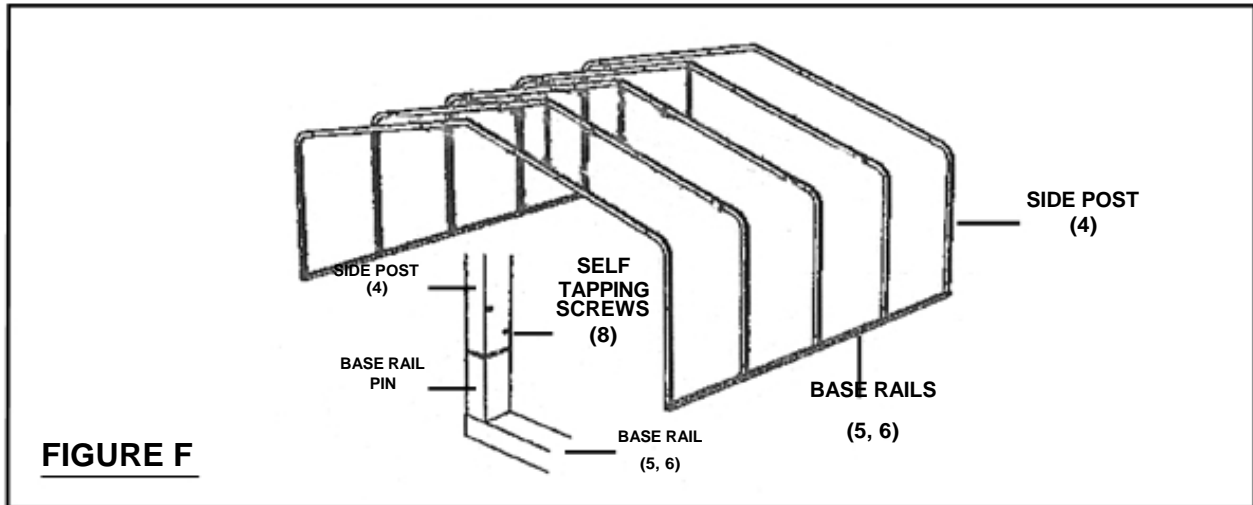

To Install The Panels On The Frame:

- Place the first Panel (1) on the roof with the under lapping edge of the Panel lined up with the previously placed marks on the Peak Tubes (2) and the end of the Panel overhanging the end of the building eleven inches. **(See Figures D and G.)**
- With the Panel (1) lined up with the marks, attach the Panel to the first frame section, using the Self Tapping Screws with Rubber Washers (9). **NOTE:** Install the Self Tapping Screws about one inch above the ribs of the Panel. **(See Figure G.)**

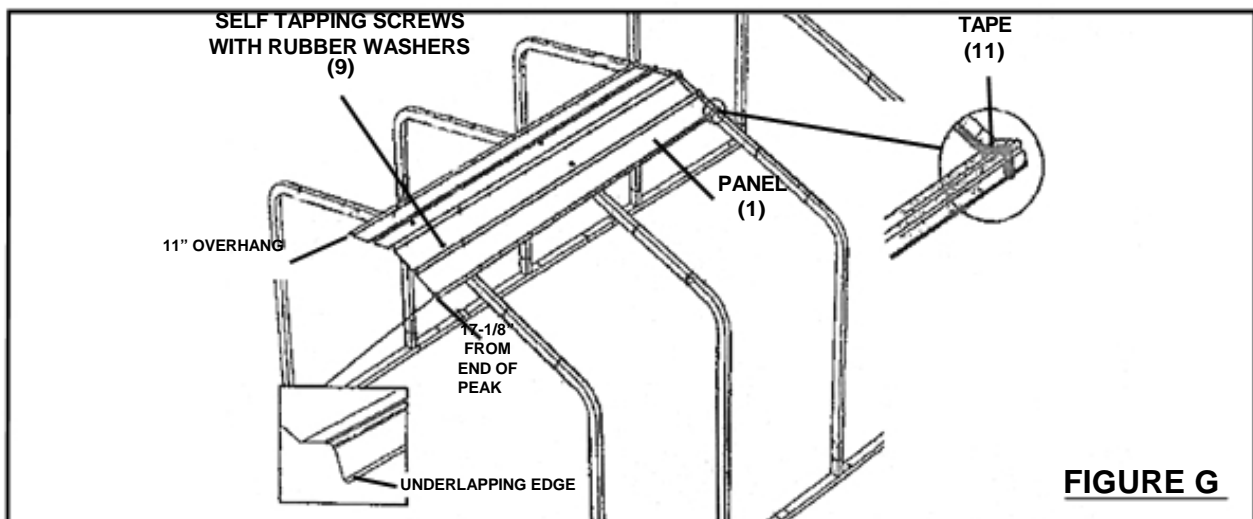

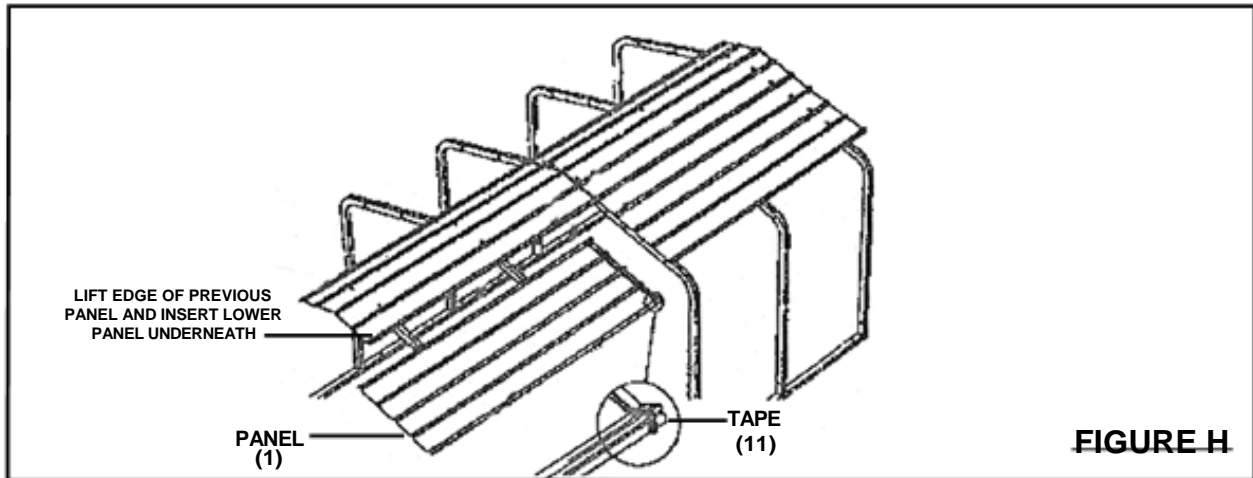

3. Run a strip of Tape (11) across the end of the Panel. **(See Figure G.)**
4. Slide the lower Panel (1) under the edges of the Panel above. Before installing the Self Tapping Screws with Rubber Washers (9), make sure the lower Panel is square with the Panel above. Then install the Self Tapping Screws with Rubber Washers. **(See Figure G.)**
5. Install all Panels (1) down the peak of the Car Shelter before moving on to the lower section of panels. **(See Figure H.)**

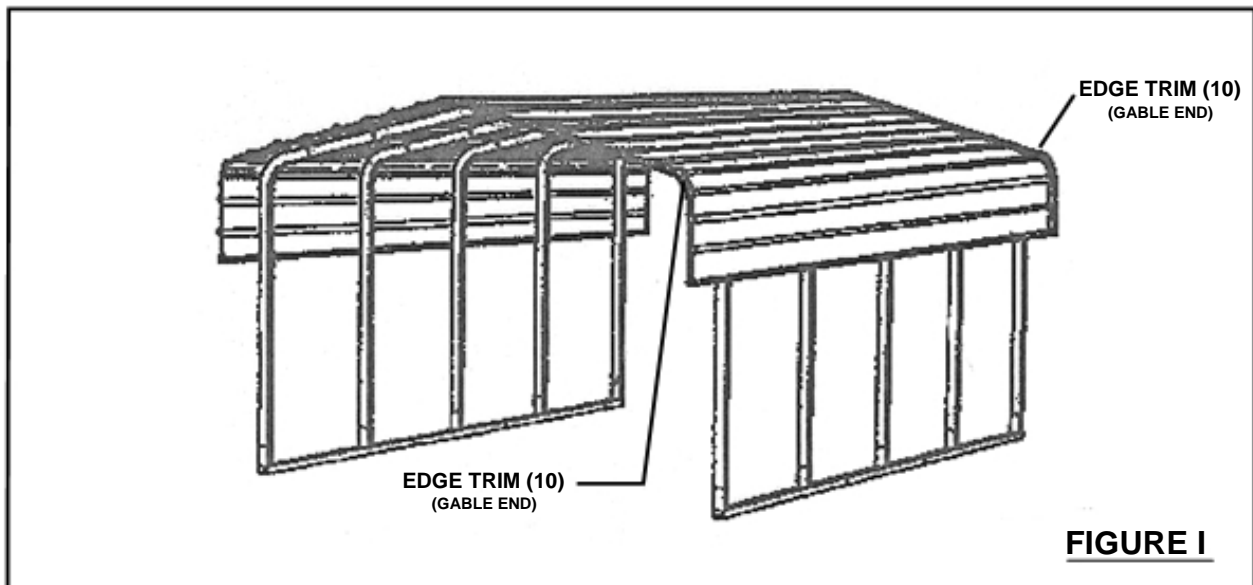

6. Continue installing Panels (1) down the peak of the Car Shelter and onward down the sides of the frame. **(See Figure I.)**
7. When finished installing the Panels (1), run a length of Edge Trim (10) along both gable ends of the Car Shelter. **(See Figure I.)**



INSPECTION, MAINTENANCE, AND CLEANING

1.  **CAUTION!** Make sure to wear ANSI approved safety impact goggles and heavy work gloves before performing any inspection, maintenance, or cleaning of the Car Shelter.
2. **Before each use:** Inspect the general condition of the Car Shelter. Check for damaged parts, loose hardware, and any other condition that may affect this product's safe operation. If a problem occurs, have the problem corrected before further use. **Do not use damaged equipment.**
3. **To clean:** Use a clean, soft, damp cloth, mild detergent, and garden hose. Then, allow to air-dry. Do not use solvents.
4.  **CAUTION!** All maintenance, service, and repairs not discussed in this manual should only be performed by a qualified service technician.

PLEASE READ THE FOLLOWING CAREFULLY

THE MANUFACTURER AND/OR DISTRIBUTOR HAS PROVIDED THE PARTS LIST AND ASSEMBLY DIAGRAM IN THIS MANUAL AS A REFERENCE TOOL ONLY. NEITHER THE MANUFACTURER OR DISTRIBUTOR MAKES ANY REPRESENTATION OR WARRANTY OF ANY KIND TO THE BUYER THAT HE OR SHE IS QUALIFIED TO REPLACE ANY PARTS OF THE PRODUCT. IN FACT, THE MANUFACTURER AND/OR DISTRIBUTOR EXPRESSLY STATES THAT ALL REPAIRS AND PARTS REPLACEMENTS SHOULD BE UNDERTAKEN BY CERTIFIED AND LICENSED TECHNICIANS, AND NOT BY THE BUYER. THE BUYER ASSUMES ALL RISKS AND LIABILITY ARISING OUT OF HIS OR HER REPAIRS TO THE ORIGINAL PRODUCT OR REPLACEMENT PARTS THERETO, OR ARISING OUT OF HIS OR HER INSTALLATION OF REPLACEMENT PARTS THERETO.

PARTS LIST AND ASSEMBLY DIAGRAM

Part #	Description	Qty.	Part #	Description	Qty.
1	Panel	10	7	Anchor Stake	10
2	Peak Tube	5	8	Self-Tapping Screw (1)	72
3	Rafter	10	9	Self-Tapping Screw (2)	165
4	Side Post	10	10	Edge Trim	22
5	End Base	4	11	Tape	25
6	Center Base	2			

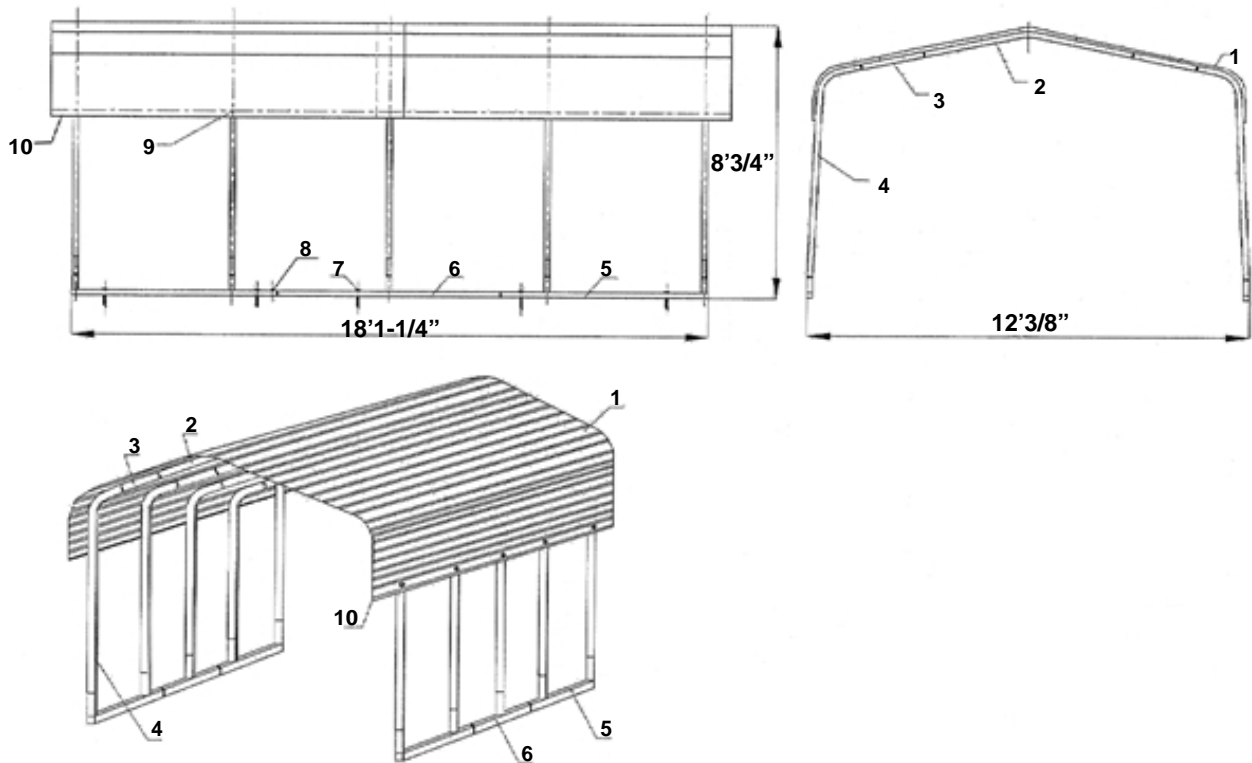

NOTE:

Some parts are listed and shown for illustration purposes only, and are not available individually as replacement parts.