

THE RIGHT Stuff®



Specializing in...

DISC BRAKE CONVERSIONS

PRE-BENT LINES • CHASSIS & SUSPENSION • E-BRAKE CABLES

28 YEARS OF BRAKING EXCELLENCE



1989-2017



What's Stopping You?

**"NO PROBLEMS,
ONLY SOLUTIONS"**

Like many businesses, The Right Stuff Detailing (TRSD) was started to fill a void in the industry by someone that had a passion for our great hobby. Since 1989, our great success has hinged on three key features – quality parts, knowledgeable staff and word of mouth.

TRSD offers a complete line of Disc Brake Conversions and Upgrades for American muscle cars and trucks. We also offer a huge selection of original equipment, replacement brake components including master cylinders, boosters, proportioning valves, emergency brake cables, fittings, clips and more.

We carry thousands of application specific pre-bent brake lines, fuel lines, transmission lines and more. Our state of the art CNC-tubing bender can produce any pre-bent lines for automotive, industrial or commercial applications. All tubing is based off an original line that is scanned using lasers. Those measurements and bends are then input into our automated bender to produce an exact duplicate for your specific application.

To finish out our product offering, we have a complete selection of original equipment, replacement suspension and chassis components.

We look forward to being part of your next project!

WHY BUY RIGHT STUFF..



TECH ADVICE • FAST SHIPPING • PERSONAL SERVICE

THE BEST SELECTION OF ORIGINAL EQUIPMENT AND PERFORMANCE UPGRADE BRAKING RELATED PRODUCTS

The Right Stuff offers award-winning products that must pass our strict third party testing and quality assurance tests. We test for endurance, compatibility, quality and material consistency.



AWARD WINNING DISC BRAKE CONVERSION KITS

Our Disc Brake Conversion Kits include only premium quality components that make the grade. We offer kits that bolt to your factory suspension and aftermarket/upgraded suspension and will work with factory size wheels or larger. Our calipers are available in raw or powder coated finish. Large diameter, zinc plated rotors are also available drilled and slotted for performance applications. Kits also include caliper brackets, rubber or braided stainless hoses, hardware, dust plates and 2" drop spindles where available. All kits are available as front, rear or 4-wheel disc and are upgradable to include a power booster and master cylinder or manual master cylinder in a standard or chrome finish. Don't forget the No Brainer pre-bent lines that are designed specifically for our disc brake conversions!



CATALOG INDEX

<i>Camaro</i>	6-26
<i>Corvette</i>	27-31
<i>Chevelle</i>	32-52
<i>Vega</i>	53
<i>Nova</i>	54-74
<i>Monte Carlo</i>	75-85
<i>1936-57 Chevy</i>	86-98
<i>1958-64 Chevy</i>	99-112
<i>1965-Up Chevy</i>	113-122
<i>GM Truck</i>	123-132
<i>Firebird</i>	133-152
<i>GTO/LeMans</i>	153-172
<i>Skylark</i>	173-194
<i>Full Size Buick</i>	181-183
<i>Cadillac</i>	195-196
<i>Oldsmobile</i>	197-216
<i>AMC</i>	217-219
<i>Mustang</i>	220-227
<i>Ford</i>	228-243
<i>Mopar A-Body</i>	244-254
<i>Mopar B-Body</i>	255-266
<i>Mopar C/D-Body</i>	267-269
<i>Mopar E-Body</i>	270-278
<i>Mopar/Dodge/Jeep Truck</i>	279-281
<i>Components</i>	282-288

POLICIES & SHIPPING INFORMATION

WE OFFER THE BEST TECHNICAL ADVICE IN THE INDUSTRY

SHIPPING

Orders are shipping via UPS or FedEx. Charges are based on actual shipping costs. Large lines require oversize shipping fees. Call or visit our website for a shipping quote. Orders outside of the Continental United States have an additional handling charge. Call for rates on overseas shipments.

RETURNS & EXCHANGES

All returns require an RMA number (return merchandise authorization number). An RMA number may be obtained by contacting TRSD's customer service departments. Items will only be accepted in new, resalable condition. If returned items are not found to be in new condition, they will be returned to the sender at his/her expense or discarded. Customers must also complete and include the Merchandise Return form found on our website or in the products original package. If the return is due to an error by TRSD, the customer will be reimbursed for normal shipping charges. A call tag can be issued by TRSD for the product to be picked up at the customer's expense.

All returns are subject to a 20% restocking fee unless an exchange order is placed for TRSD products. Contact our customer service department for additional details.

DEFECTIVE PRODUCT RETURNS

Any product determined to be defective or that becomes unserviceable due to workmanship will be replaced at no cost to the original purchaser only. Do not return TRSD products to any authorized dealer until you have contacted TRSD first. Our customer service department will instruct you on return procedures after they have determined the product is defective. An RMA number will be issued and we will provide you with the appropriate shipping instructions.

MISSING ITEMS – Any component shortages or missing parts/assemblies from the original purchase must be reported to TRSD within 30 days of receiving the shipment. After this time, it is TRSD's discretion as to whether or not the missing parts will be sent.

WARRANTY

The Right Stuff products carry a limited lifetime warranty to be free of defects in material and workmanship. The warranty is void if the product has been altered, improperly installed or used for purposes other than originally intended.

DISCLAIMER

TRSD will not be responsible for any damage or loss caused by delays, failures or any consequential damage arising from any cause whatsoever, nor the labor, transportation or mechanical damage caused by the use or misuse of products. We are not responsible for typographical or production errors.

NEW PATTERNS & FREE LINES

All of our lines are patterned from original lines supplied by customers like you. If you need lines that we have a category for but your application is not listed, you may qualify for free lines! Lines for unlisted categories may qualify for a less discount of 30-50% off. Call us to see if you qualify for this program. We will provide instructions on shipping the lines to us. Lines must be blown out and reasonably free of grease and oil. The start and end points of each line should be clearly labeled to show where they fit on the vehicle.

TABLE OF CONTENTS

THE COMPLETE AUTOMOTIVE BRAKE & SUSPENSION EXPERTS

CAMARO 6-26	CHEVY & GMC TRUCK .. 125-134	MUSTANG 222-229
Brakes..... 6-11	FIREBIRD 135-154	Brakes..... 225-227
Fuel..... 12-14	Brakes..... 135-140	Fuel..... 227-229
Transmission..... 14	Fuel..... 140-142	Transmission..... 228
Suspension..... 10, 15-16	Transmission..... 140	Disc Conversions..... 223-224
Disc Conversions..... 16-26	Suspension..... 137, 143	
CORVETTE 27-31	Disc Conversions..... 144-154	FORD CAR & TRUCK 230-245
Brakes..... 27-29	GTO/LEMANS 155-174	Brakes..... 230-234, 236, 238
Fuel..... 29-30	Brakes..... 155-160	240, 241, 243-245
Transmission..... 31	Fuel..... 160-162	Fuel..... 231-232, 234-237, 239
Suspension..... 31	Transmission..... 162	241-242, 245
CHEVELLE/EL CAMINO/MALIBU ... 32-52	Suspension..... 163-164	Transmission..... 231-232, 235
Brakes..... 32-37	Disc Conversions..... 164-174	237-238, 242, 244
Fuel..... 38-41	SKYLARK/GS 175-196	MOPAR A-BODY 246-256
Transmission..... 39	Brakes..... 175-180	Brakes..... 246-249
Suspension..... 35, 41-42	Fuel..... 180-181	Fuel..... 249-250
Disc Conversions..... 42-52	Transmission..... 178	Transmission..... 248
VEGA/CORVAIR 53	Suspension..... 182	Suspension..... 251
NOVA/CHEVY-II 54-74	Disc Conversions..... 186-196	Disc Conversions..... 252-256
Brakes..... 54-59	FULL SIZE BUICK 183-185	MOPAR B-BODY 257-268
Fuel..... 60-61	Brakes..... 183-184	Brakes..... 257-260
Transmission..... 61-62	Fuel..... 185	Fuel..... 260-262
Suspension..... 57, 62, 64	CADILLAC 197-198	Transmission..... 262
Disc Conversions..... 64-74	OLDSMOBILE 199-218	Suspension..... 263
MONTE CARLO 75-85	Brakes..... 199-204	Disc Conversions..... 264-268
Brakes..... 75-78	Fuel..... 204-205	MOPAR C/D-BODY 269-271
Fuel..... 79-80	Suspension..... 201, 205-206	Brakes..... 269-270
Transmission..... 79	Disc Conversions..... 206-215, 218	Fuel..... 270-271
Suspension..... 76, 80-81	FULL SIZE OLDSMOBILE . 216-217	Transmission..... 271
Disc Conversions..... 81-85	Brakes..... 216	MOPAR E-BODY 272-280
1936-57 CHEVY 86-99	Fuel..... 217	Brakes..... 272-274
Brakes..... 86-88	INTERNATIONAL 219	Fuel..... 274-275
Fuel..... 87-88, 90	MG 219	Transmission..... 275
Transmission..... 89	NASH 219	Suspension..... 276
Suspension..... 89	PACKARD 219	Disc Conversions..... 277-280
Disc Conversions..... 92-99	STUDEBAKER 219	MOPAR MISC CARS 281
1958-64 CHEVY 100-113	NISSAN 219	DODGE TRUCK & JEEP ... 281-283
Brakes..... 100-103	KAISER 219	Brakes..... 282-283
Fuel..... 103-104	AMC/AMX 220-221	Fuel..... 281-283
Transmission..... 105	Brakes..... 220-221	Transmission..... 281-282
Suspension..... 105	Fuel..... 221	INDIVIDUAL COMPONENTS 284-289
Disc Conversions..... 106-113	Transmission..... 221	
1965-UP CHEVY 114-124		
Brakes..... 114-117		
Fuel..... 116-118		
Transmission..... 118		
Suspension..... 120		
Disc Conversions..... 120-124		



CAMARO BRAKE LINES

FRONT BRAKE LINE KITS

Front brake line kits consist of all brake lines under the hood. This includes the master cylinder to the distribution, combination or metering valve. The left and right front lines that run to the front flex hoses are also included. Call for individual component pricing. These line kits are for vehicles with factory brake systems.

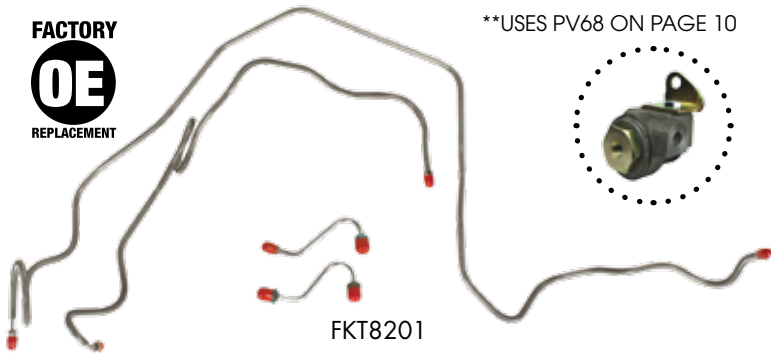

FKT8201

**USES PV68 ON PAGE 10

FRONT TO REAR BRAKE LINES

Front to rear brake lines go from the distribution, combination or metering valve along the length of the vehicle to the rear flex hose. Lines are manufactured in 1 or 2 pieces based on factory specifications.



*USES FMB6701 ON PAGE 10

ADD "S" TO PART NUMBER FOR STAINLESS STEEL

FIN6701.....67 Front to Rear with Serial # Above with FKT6701	
FIN6703.....67 Manual Drum with Serial # Below with FKT6702	
FIN6702.....67 Front to Rear* 2 Pcs
FIN6701.....68 Front to Rear	
FIN6802.....68 Front to Rear* 2 Pcs
FIN6901.....69 Power Disc or Drum	
FIN6902.....69 Power Disc or Drum* 2 Pcs
FIN6903.....69 Manual Disc or Drum	
FIN6906.....69 Manual Disc or Drum* 2 Pcs
FIN7001.....70 Power Disc	
FIN7002.....70 Manual Disc	
FIN7101... 71-73	... Power Disc	
FIN7401... 74-76	... Power Disc	
FIN7801... 77-81	... Power Disc	
FIN8201... 82-83	... 4 & 6 Cylinder	
FIN8202... 82-83	... V-8	
FIN8401... 84-85	... 4 & 6 Cylinder	
FIN8402... 84-85	... V-8	
FIN8601... 86-92	... All	
FIN9301... 93-94	... Z-28, 6 Cylinder, Power Disc	

ADD "S" TO PART NUMBER FOR STAINLESS STEEL

FKT6702	67 Standard Drum with Serial # Below Use with FIN6703 4 Pcs
FKT6701 ..	67-68	... Standard Drum with Serial # Above Use with FIN6701 4 Pcs
FKT6703 ..	67-68	... Power Drum 4 Pcs
FKT6705 ..	67-68	... Standard Disc ** 5 Pcs
FKT6707 ..	67-68	... Power Disc ** 5 Pcs
FKT6901	69 Standard Drum 4 Pcs
FKT6903	69 Power Drum And JL-8 4 Pcs
FKT6905	69 Power Disc ** 5 Pcs
FKT6908	69 Standard Disc, Car with Power Booster Removed For Big Block 5 Pcs
FKT7004	70 Standard Disc 7 Pcs
FKT7005	70 Power Disc Front Master Cylinder Line without Armor 7 Pcs
FKT7006	70 Power Disc Front Master Cylinder Line with Armor 7 Pcs
FKT7101	71 Manual Disc 4 Pcs
FKT7102 ..	71-79	... Power Disc 4 Pcs
FKT8002 ..	80-81	... Power Disc 4 Pcs
FKT8201 ..	82-83	... V-8 4 Pcs
FKT8206 ..	82-83	... 4 & 6 Cylinder 4 Pcs
FKT8401 ..	84-85	... V-8 4 Pcs
FKT8406 ..	84-85	... 4 & 6 Cylinder 4 Pcs
FKT8601 ..	86-89	... V-8, 1st Design Valve 4 Pcs
FKT8606 ..	86-89	... 6 Cyl, 1st Design Valve 4 Pcs
FKT8901 ..	89-92	... V-8, 2nd Design Valve 4 Pcs
FKT8904 ..	89-92	... 6 Cyl, 2nd Design Valve 4 Pcs
FKT9307 ..	93-97	... Z-28, 4Wheel Disc 4 Pcs

REAR AXLE BRAKE LINES

Rear axle brake lines include a pair of lines that run across the rear axle housing & connect the wheel cylinders or calipers to the flex hose in the middle of the rear end. These lines work with original housings that use factory brakes. Modifications such as rear disc brakes or narrowed rear ends will likely require special lines. Call for more information.



FRA7801

ADD "S" TO PART NUMBER FOR STAINLESS STEEL

FRA6702	67 Mono Leaf Spring 2 Pcs
FRA6802	68 Mono Leaf Spring 2 Pcs
FRA6805	68 Multi Leaf Spring 2 Pcs
FRA6902	69 Multi Leaf Spring 2 Pcs
FRA69JL.....	69 with JL-8 Rear Disc 2 Pcs
FRA7002 ..	70-74	... All Cars 2 Pcs
FRA7801 ..	75-81	... Standard Rear Suspension 2 Pcs
FRA8002 ..	75-81	... F-41 Rear Suspension 2 Pcs
FRA82RD	82 4 Wheel Disc 2 Pcs
FRA8401 ..	84-92	... Rear Drum w/o Borg. Warner	2 Pcs
FRA8602 ..	86-92	... Rear Disc Excl. Borg Warner	... 2 Pcs
FRA8601 ..	86-92	... Rear Disc with Borg. Warner	... 2 Pcs
FRA9301 ..	93-96	... Rear Drum 2 Pcs
FRA9501 ..	93-97	... 4 Wheel Disc, 2 Pcs

HOSE CLIPS



These brackets and hardware are used to secure flex hoses to various parts of the vehicle. Front brackets are sold in pairs.

- RSBK6712 ...67-68... 12 Bolt Rear Hose Bracket
- RSBK6702 ...67-68... Rear Body Mount Hose Bracket
- RSBB0167-68... Rear Hose Brass 'T' Block
- RSBK6767-68... Front Hose to 4 Piston Caliper Brackets (pr)
- RSBK69 69 Front Flex Hose Frame Brackets, Includes 2 Brackets, Clip, & 2 Grommets
- RSBK09 69 12 Bolt Rear Hose Bracket
- FHC01 All Correct Gold Cadmium Plated C Clips
- BB6901 69 Banjo Bolt
- CW6901 69 Copper Washer

DISC CALIPER LINES

Front disc caliper lines connect the front flex hoses to the calipers. They were typically used on 4 piston calipers in the late 1960's. Several fitting sizes were available from the factory. Please verify fitting sizes before ordering as rebuilt calipers may not match the originals.



4-PISTON CALIPER INLET LINES
Early '67 Camaro's had 3/8" on both sides. In mid '67 thru '68 GM switched to a 7/16" inlet on the left (DRIVER) caliper and 1/2" on the right (PASSENGER) caliper.

ADD "S" TO PART NUMBER FOR STAINLESS STEEL

- FFC6701 .. 67-68 ... 3/8" x 3/8" Left
- FFC6702 .. 67-68 ... 3/8" x 3/8" Right
- FFC6703 .. 67-68 ... 3/8" x 7/16" Left
- FFC6704 .. 67-68 ... 3/8" x 7/16" Right
- FFC6705 .. 67-68 ... 3/8" x 1/2" Left
- FFC6706 .. 67-68 ... 3/8" x 1/2" Right
- FFCJL8L.....69 3/8" x 1/2", JL8, Left
- FFCJL8R69 3/8" x 7/16", JL8, Right

BRAKE LINE CLIPS

Brake line clip sets contain all the clips needed to fasten the brake tubes to the frame or body of the car. Individual clips and fasteners are available on pages 284-285.



- FCS001 67-68 ... Complete Set 10 Pcs
- FCS002 69..... Complete Set 12 Pcs
- FCS008 70..... Complete Set 21 Pcs
- FCS011 71-73 ... Complete Set 25 Pcs
- FCS014 75-81 ... Complete Brake & Fuel with Bolts 32 Pcs

FRONT FLEX HOSES

Front flex hoses provide a flexible connection from the body or frame to the front calipers or wheel cylinders as they move during suspension travel. Choose between O.E. rubber or braided stainless steel. All of our hoses are D.O.T. approved. Hoses are priced individually.



ADD "S" TO PART NUMBER FOR STAINLESS STEEL

- FH32.....67 Front Drum
- FH01 67-68 ... Front Disc
- FH02..... 68-69 ... Front Drum
- FH03.....69 Front Disc
- FH30.....69 Front, JL-8 Only
- FHB69.....69 Clip, FH03 To Upper Cntrl. Arm, 2 Pcs
- FH202..... 70-71 ... Front Disc
- FH07 72-73 ... Front Disc
- FH31 74-76 ... Front Disc
- FH08..... 77-78 ... Front Disc
- FH09..... 79-81 ... Front Disc
- FH175..... 82-83 ... Left Front
- FH176..... 82-83 ... Right Front
- FH158..... 84-92 ... Left Front Ex. Perf. Package, Metric
- FH160..... 84-92 ... Right Front Ex. Perf. Package, Metric
- FH159..... 88-92 ... Left Front with Perf. Package
- FH161..... 88-92 ... Right Front with Perf. Package

REAR FLEX HOSES

Rear flex hoses carry brake fluid between the body of the car and the rear. Hoses are available in O.E. rubber and braided stainless steel. 'T' blocks are attached whenever factory correct. All of our hoses are D.O.T. approved. Prices are per hose.



ADD "S" TO PART NUMBER FOR STAINLESS STEEL

- FH04.....67 Rear-All
- FH05.....68 Rear-All
- FH06.....69 Rear-All
- FH10..... 70-72 Rear-All
- FH11 73 Rear-All
- FH12..... 74-75 Rear-All
- FH13..... 76-81 Rear-All, Except Z-28
- FH173..... 82-83 Rear-All, Except 83 Rear Disc, SAE
- FH174.....83 Rear Disc, Passenger Side, SAE
- FH156.... 84-92 Rear Drum Ex. Perf. Pkg. Center Axle
- FH157.... 84-88 Rear Disc, Passenger Side, Metric
- FH155..... 88 Left Rear Disc, with Perf. Package
- FH177..... 88 Right Rear Disc, with Perf. Package
- FH155.... 89-92 Left Rear Disc
- FH177.... 89-92 Right Rear Disc

CAMARO E-BRAKE & DRUM BRAKES

E-BRAKE CABLES

Parking brake cable sets contain all the individual cables and hardware needed to restore the system. Front, rear, and intermediate cables are also sold individually, while supplies last. Sold in O.E. mild steel and stainless steel.



ADD "S" TO PART NUMBER FOR STAINLESS STEEL

• E-Brake Cable Kits

- RSBCF0167 Full Cable Set with All Hardware
- RSBCF02 .. 68-69 ... Full Cable Set with All Hardware
- RSBCF03 .. 70-74 ... Full Cable Set with All Hardware
- RSBCF04 .. 75-81 ... Full Cable Set with All Hardware

• Front Brake Cables

- EBC7002.. 67-69 ... All Cars
- EBC7004.. 70-74 ... All Cars
- EBC7020.. 75-81 ... All Cars

• Intermediate Brake Cables

- EBC8002.....67 All Cars
- EBC8003.. 68-69 ... All Cars

• Rear Brake Cables

- EBC9002.....67 All Cars
- EBC9003.. 68-69 ... All Cars
- EBC9006.. 70-74 ... All Cars

• E-Brake Hardware

- EBH3001 67-74 Olive Green Center Pull
- EBH3002.... 67-81 Center to Rear Silver Connector
- RSCLP23 67-81 Parking Brake Clip - Black
- EBH2003 67-69 12' Silver Hook
- EBH1001 67-81 ... Jam Nut
- EBH2004.... 70-74 J Hook
- EBH1002.... 70-74 Spring

WHEEL CYLINDERS

Wheel cylinders are priced individually. Hardware is not included.



- WC01.....67-69..... Left Front
- WC02.....67-69..... Right Front
- WC03.....67-75..... Rear Left or Right
- WC04.....76-81..... Rear Left or Right
- WC56.....82-86..... Rear with US Thread
- WC57.....84-92..... Rear with Metric 10x1.0 Thread

DRUM BRAKES

Brake drums are sold individually.



- BD11 67-69 Front Drum, Non-Finned
- BD12 67-72 Front Drum, Finned
- BD01 67-74 Rear Drum, Finned

BRAKE SHOES

Shoes are sold in sets of four. Upgrade to the Silencer Precision series for quiet, low dust braking and longer shoe life.



SILENCER PRECISION

- BS01 67-69 9" Drum Shoes, 2 pr, Standard Organic
- BS245 67-81 9" Drum Shoes, 2 pr, Silencer Precision

DRUM COMPONENTS

Available components include backing plates, adjusters and spring sets. Brake drum hardware kits contain the springs and retainers needed to rebuild an original drum brake assembly. Adjusters are sold in pairs.

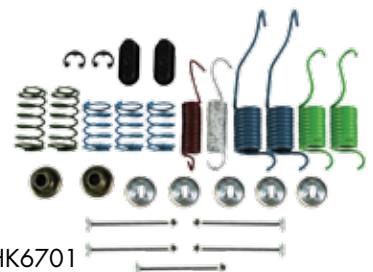

- DHK6701 67-69 ... Front Drum Hardware (2 Sets)
- DHK6702 67-88 ... Rear Drum Hardware (2 Sets)
- DHK6703 67-88 ... Adjusters, Front or Rear (2 Pcs)
- DBBP81L..... 67-69 ... 9" Drum Backing Plate, Left Rear
- DBBP81R 67-69 ... 9" Drum Backing Plate, Right Rear

CALIPERS

New calipers are supplied loaded with pads*, banjo bolts and copper washers. No core charge applies. Mounting pins are provided when applicable. Black and Red powder coating options provide a smooth, finished look that is unaffected by leaking brake fluid. *Rebuilt and new 4 piston calipers do not include pads or hardware. Core charges apply as noted.

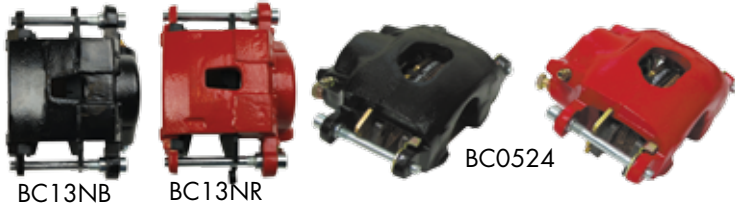

- BC01L.....67-68.... Left, 4 Piston, Stainless Sleeve, with Exchange
- BC01LC.....67-68.... Left, Core Charge
- BC01R.....67-68.... Right, 4 Piston, SS Sleeve, with Exchange
- BC01RC.....67-68.... Right, Core Charge
- BC22L.....67-68.... Left, Great 4 Piston Caliper Reproduction, All New Parts, Stainless Sleeve, No Core!
- BC22R.....67-68.... Right, Great 4 Piston Caliper Reproduction, All New Parts, Stainless Sleeve, No Core!
- BC03LN.....69..... Left, New with Pads
- BC03RN.....69..... Right, New with Pads
- BC4344.....69..... Red or Black Powdercoat (pr)
- BC0424.....70-77.... Red or Black Powdercoat (pr)
- BC0524.....78-81... Red or Black Powdercoat (pr)
- BC12N.....82-87.... Left Front, New with pads
- BC13N.....82-87.... Right Front, New with pads
- BC1213.....82-87.... Red or Black Powdercoat (pr)

CALIPER BRACKETS

Yellow zinc plating provides corrosion protection on these reproduction brackets.

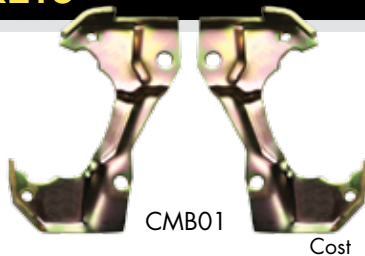

- CMB06.....67-68... 4 Piston Caliper Brackets (pr)
- CMB01.....69..... Single Piston Caliper Brackets (pr)

BACKING PLATES

Often called dust shields, these plates provide some level of protection from road debris.



- DBBP03.....67-68... 4 Piston Backing Plates (pr)
- DBBP01.....69..... Single Piston Backing Plates (pr)

DISC BRAKE PADS

Brake pads are sold in sets of four. Our base line is a midgrade standard offering. Step up to the Silencer Professional line for less dust, quieter braking, and longer pad life.



- DP01..... 67-68 4 Piston Caliper Pads (2 pr)
- DP02..... 69-81 Single Piston Caliper Pads (2 pr)
- DP23..... 82-87 Single Piston Caliper Pads (2 pr)
- DP23..... 67-92 Rear Pads (2 pr), with RSD Rear Disc

ROTORS

Brake rotors are shipped with bearing races installed. A Drilled-Slotted-Zinc Plated option is available on select rotors.



- BR01C..... 67-68 ... Front Rotor, 4 Piston, 1 Pc Design
- BR69C..... 67-69 ... Front Rotor, 4 Piston, 2 Pc Design
- BR02C.....69 Front Rotor, 1 Pc Design
- BR03C..... 70-78 ... Front Rotor
- BR04C..... 79-81 ... Front Rotor

MINI KITS

Mini kits include a pair of spindles, caliper brackets, and backing plates. These kits are a great value to freshen up the front end on a restoration project, or to build out a drum to disc brake conversion.

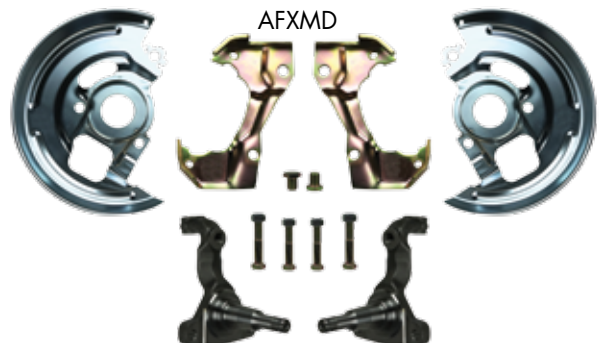

- AFXMD.....67-69... Standard Height, Single Piston Calipers
- AFXMD4.....67-69... 2" Drop, Single Piston Calipers
- AFXMD3.....67-69... Standard Height, 4 Piston Piston Calipers

CAMARO MASTER CYLINDERS & SPINDLES

MASTER CYLINDERS

All master cylinders are completely new units with no core charge. A deep cylinder pocket with a removable plug provides compatibility with manual brakes as well as power-assisted applications.



- DBMC0967-69... Power Disc, 1-1/8" Bore, Deep Pocket
- DBMC1167-69... Power Disc, with Bleeders, 1-1/8" Bore, Deep, Exact Repo for '69, Delco Licensed
- DBMC1667-69... Power Disc, with Bleeders, 1-1/8" Bore, Deep, Same as DBMC11 without Casting Marks
- DBMC0170-81... Power Disc, 1-1/8" Bore, Shallow Pocket
- DBMC1970-81... 1-1/8" Bore, with Bleeders
- DBMC09C...67-81... 1-1/8" Bore, Chrome
- DBMC05C...67-81... 1" Bore, 4 Wheel Disc, Chrome
- DBMC51C...67-81... 1-1/8" Bore, Slimline Flat Top, Chrome
- DBMC56C...67-81... 1" Bore, Slimline Flat Top, Chrome

SPINDLES

Our spindles are forged steel with precision CNC machining. Two hard to find caliper mounting bolts are included with each pair of spindles. 2" drop installations require caliper bracket and backing plate modifications. All listings are for disc brake systems. Call for drum brake applications.



- DBSP0167-69... Disc Brake Spindles with Large Bolts (pr)
- DBSP0467-69... 2" Drop Disc Brake Spindles with Bolts (pr)
- DBSP7078 ...70-78... 2" Drop Disc Brake Spindles (pr)
- DBSP7981 ...79-81... 2" Drop Disc Brake Spindles (pr)

VALVES & BLOCKS

We offer a full line of metering blocks, proportioning valves, distribution blocks and combination valves for factory drum and disc brake applications.

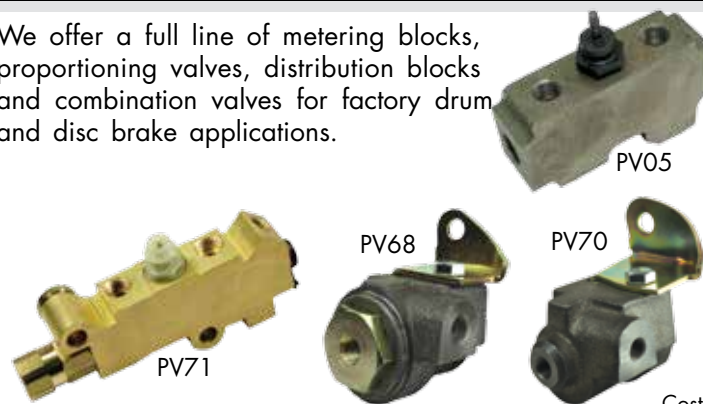

- PV6867-69..... Hold-Off Valve (with Bracket)
- PV0567-69..... Distribution Block (with Bracket)
- PV7070..... Hold-Off Valve (with Bracket)
- PV7171-81..... Combination Valve
- PVB7371-81..... Combination Valve Bracket
- FMB67011967-69..... Hold-Off Valve
- FMB70011970..... Hold-Off Valve

POWER VACUUM LINES

Power brake vacuum lines connect the intake manifold fitting to the rubber hose that runs to the power brake booster. Brackets are included as noted.

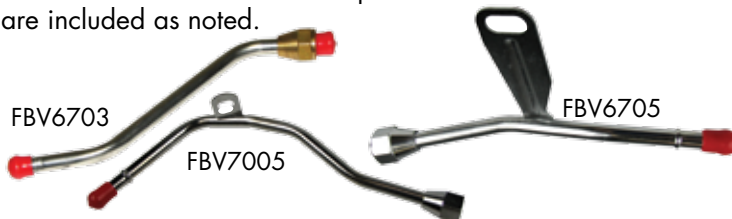

ADD "S" TO PART NUMBER FOR STAINLESS STEEL

- FBV6703 .. 67-69 ... Small Block
- FBV6705 .. 67-69 ... Big Block (Includes Bracket)
- FBV700570 Big Block (Includes Bracket)
- FBV780378 350, 4 BBL
- FBV800580 305, 4 BBL

INTAKE FITTINGS

Intake manifold fittings screw into your factory intake manifold to distribute vacuum to various systems.



- IMF67ZZ67-69... 3/8" Thread with 1-3/8", Hose Cntr. Z28
- IMF670567-70... Big Block, 4 Speed, (Also 68-69 SB with 4 BBL)
- IMF670667-70... Big Block, Automatic
- IMF670767-70... Big Block with AC & Automatic
- IMF68RS.....68-69... 3/8" Thread with 2 ports, (Rally Sport)

SLIMLINE BOOSTER MASTER COMBOS

J81315672

The slimline combos offer clean lines and plenty of power in a small package. The 8" dual is our favorite. Mounting brackets included.



J81315672 TOP VIEW

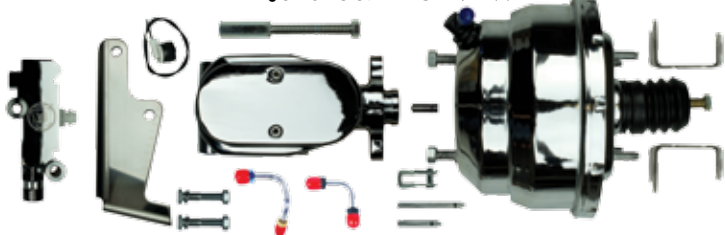

- G8131097167-69 8" Dual, Standard Gold, Disc/Drum
- J81315171.....67-69 8" Dual, Chrome, Disc/Drum
- G81310572.....67-69 8" Dual, Standard Gold, Disc/Disc
- J81315672.....67-69 8" Dual, Chrome, Disc/Disc
- G9102097167-69 9" Single, Standard Gold, Disc/Drum
- G91020572.....67-69 9" Single, Standard Gold, Disc/Disc

SLIMLINE BOOSTERS

Slimline boosters pack a lot of punch in a small, sleek package. Dual diaphragm versions provide 25% - 35% more assist than their single diaphragm equivalent. The 8" dual is our most popular for clearing big blocks while providing plenty of assist for two or four wheel disc brake systems. Mounting brackets included.



- RPB7137 67-69 7" Dual, Standard Gold
- RPB7137C 67-69 7" Dual, Chrome Plated
- RPB7137S 67-69 7" Dual, Polished Stainless
- RPB8131 67-69 8" Dual, Standard Gold
- RPB8131C 67-69 8" Dual, Chrome Plated
- RPB8131S 67-69 8" Dual, Polished Stainless
- RPB9102 67-69 9" Single, Standard Gold

DELCO BOOSTER MASTER COMBOS

Factory style for 67-81 GM. Can be tight on big block cars. Available with or without Delco stamping. Mounting brackets included.



FDC001

FDC001 TOP VIEW

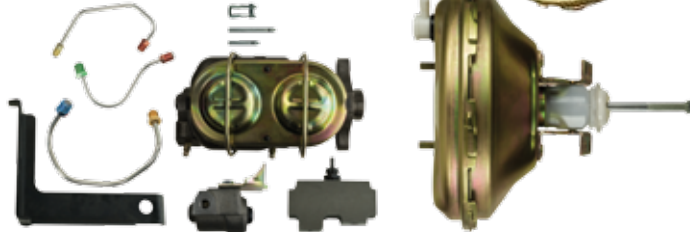

- G91210971 67-69 9" Single, Standard Gold, Disc/Drum
- J91215171..... 67-69 9" Single, Chrome, Disc/Drum
- G91210572 67-69 9" Single, Standard Gold, Disc/Disc
- J91215672..... 67-69 9" Single, Chrome, Disc/Disc
- G10030971 67-69 11" Single, Standard Gold, Disc/Drum
- J10035171..... 67-69 11" Single, Chrome, Disc/Drum
- G10030572 67-69 11" Single, Standard Gold, Disc/Disc
- J10035672..... 67-69 11" Single, Chrome, Disc/Disc
- G10011168 69..... 11" Single, Factory Correct Disc/Drum
- FDC001 69..... 11" Single, Factory Correct Disc/Drum
- G10060171 71-81 11" Single, Standard Gold, Disc/Drum
- G10070171 71-81 11" Single, Standard Gold w/ stamp
- G10060572 71-81 11" Single, Standard Gold, Disc/Disc

DELCO BOOSTERS

Reproductions based on original factory units. GM licensed & feature a Delco Moraine stamping. This logo is available right side up and upside down. Unstamped boosters are of identical quality, but less expensive without the licensing fees. Includes mounting brackets.



- RPB902267-69... 9" Standard Gold
- RPB9121C...67-69... 9" Chrome Plated
- RPB901667-69... 9" Standard Gold, with Delco Stamping
- RPB100367-69... 11" Standard Gold
- RPB1003C...67-69... 11" Chrome Plated
- RPB100167-69... 11" Std.Gold, with Right Side Up Delco
- RPB100867-69... 11" Std.Gold, with Upside Down Delco
- RPB100670-81... 11" Standard Gold
- RPB100770-81... 11" Standard Gold, with Delco Stamping

CAMARO FUEL SYSTEM LINES

FUEL PUMP TO CARB LINES

Fuel pump to carburetor lines connect the fuel pump to the carburetor. Brass blocks and fittings are included as noted. These lines are intended to work only with factory pump, motor, intake and carburetor combinations.

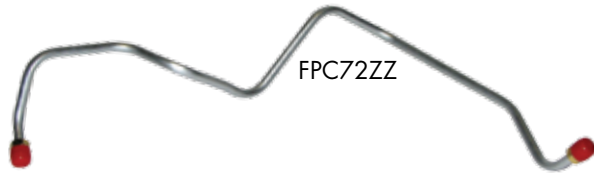

ADD "S" TO PART NUMBER FOR STAINLESS STEEL

- FPC670167 230 6 Cylinder 5/16"
- FPC670267 327/210 HP Before April 1967, 2 BBL
- FPC670267 327/210 HP Before April 1967, 2 BBL
- FPC6703 .. 67-68 ... 67 Late, 68 All, 327/210 HP
- FPC6705 .. 67-68 ... 350/295 & 327/275, 4 BBL, 5/16"
- FPC6709 .. 67-68 ... 396/325 HP
- FPC6775 .. 67-68 ... 396/375 HP with Block, D.S. Alt 3 Pc
- FPC67ZZ .. 67-68 ... 302, 3 Lines & Fuel Block
- FPC6707 .. 67-69 ... 327/275 & 350/295, 4 BBL, 3/8"
- FPC6801 .. 68-70 ... 250, 6 Cylinder, 1BBL, 5/16"
- FPC690169 350 2 BBL, 3/8"
- FPC690269 307, 327, 2 BBL, 5/16"
- FPC690369 396/325-350 HP with Return
3 Piece For Use with AC Filter
- FPC690569 350/255 or 300 HP with Return
For Use with AC Filte 3 Pcs
- FPC697569 396/375 HP, 3 Lines & Fuel Block
- FPC69XR69 Cross Ram, No Block Included 5 Pcs
- FPC69NN.....69 Eldebrock Carb & Manifold
- FPC69ZL.....69 Al. 427ci. with Dual Feed Holley
- FPC69ZZ .. 69-71 ... Z-28 with Dual Feed Holley
3 Lines & Fuel Block
- FPC700570 BB with Quadrajct
- FPC7001 .. 70-74 ... 350 with Quadrajct
- FPC7203 .. 71-72 ... 402 with Q-Jet, Use with Filter 3 Pcs
- FPC7103 .. 71-73 ... LT, 350 ci, 2 BBL
- FPC72ZZ72 350, 4 BBL, Z-28 with Quadrajct
- FPC770177 250, 2 BBL
- FPC7801 .. 78-80 ... V-8, 2 BBL
- FPC7802 .. 78-80 ... 305, 4 BBL
- FPC8001 .. 79-81 ... 350 with Quadrajct
- FPC8202 .. 82-85 ... Crossfire 3 Pcs
- FPC870187 4 BBL

THERMAL CHOKE LINES

Thermal choke lines carry heat from the exhaust system to the choke coil on the carburetor. Some applications route thru the intake manifold on their way to the carburetor.

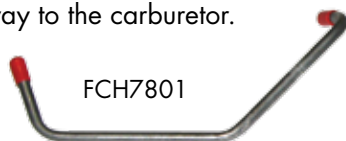

ADD "S" TO PART NUMBER FOR STAINLESS STEEL

- FCH780178 350ci, 4 BBL
- FCH79ZZ.....79 350ci, Quadrajct

HOLLEY CARBURETOR PARTS

Components are used to accommodate various configurations of replacement and stock Holley carburetors with dual fuel inlets.

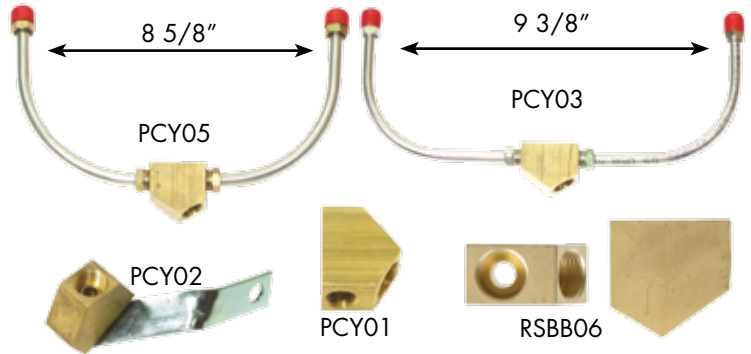

ADD "S" TO PART NUMBER FOR STAINLESS STEEL

- PCY01 Y Block without Bracket, Brass
- PCY02 Y Block with Bracket, Brass.
- RSBB06 ... Y Block with 3/8" Ports, Used in PCY05, Brass
- PCY03 Original Dual Feed Holley Carb Lines 5/16" Inlets,
8-5/8" Center To Center with Block
- PCY05 Replacement Dual Feed Holley Lines 3/8" Inlets,
8-5/8" Center To Center with Block
- PCY07 Replacement Dual Feed Holley Lines 3/8" Inlets,
9-3/8" Center To Center with Block

VAPOR RETURN LINES

Emission control systems use these 5/16" lines to handle fuel vapors. Some vehicles use a single front to rear line. Others utilize a charcoal canister and require 3 or 4 additional small lines. Multiple piece sets are noted.

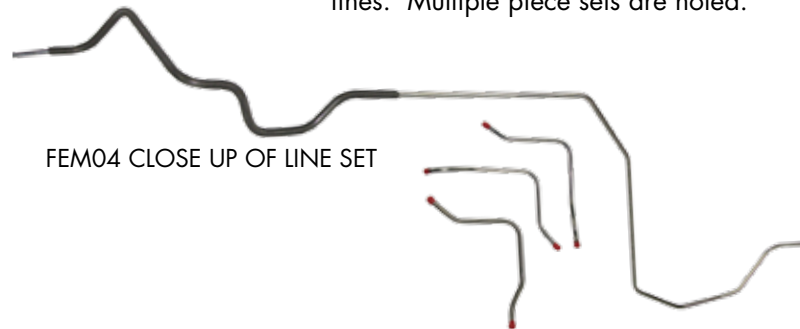

ADD "S" TO PART NUMBER FOR STAINLESS STEEL

- FST680168-70 Smog Extension Tubes
- FEM0470-73 4 Piece Set
- FEM0370-74 6 Cylinder, 1 Piece Set
- FEM7474 4 Piece Set
- FEM0575-77 1 Piece Set
- FGL760376 5/16" Vapor Line
- FGL770477 5/16" Vapor Line
- FEM0878 2 Piece Set
- FEM1079-81 2 Piece Set
- FGL8206 ...82-84 5/16" Vapor Line, LH
- FGL8504 ...85-91 1/4" Vapor line, Carb, LH
- FGL8509 ...85-91 5/16" Vapor Line, RH
- FGL8510 ...85-91 5/16" Vapor Line, LH

MAIN FUEL LINES

Main lines carry fuel from the tank in the rear of the car to the fuel pump or rail in the front. They are available in 3/8" and 5/16" tubing based on factory specifications. Multiple piece sets are noted. Call for 1/2" lines.

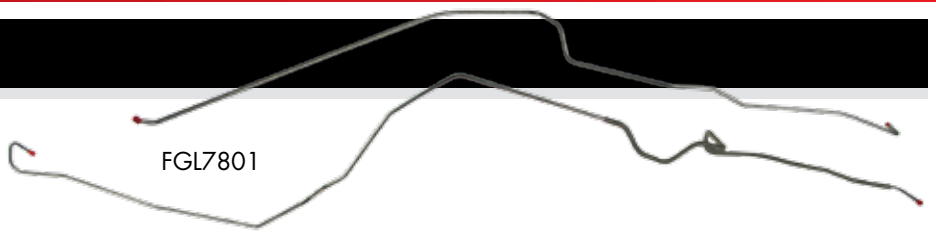

ADD "S" TO PART NUMBER FOR STAINLESS STEEL

- FGL670367 V-8 Small Block 3/8"
- FGL670467 V-8 Big Block 3/8"
- FGL6701 .. 67-68 ... 6 Cyl. 5/16" Fuel Line
- FGL680368 V-8 Small Block 3/8"
- FGL680568 V-8 Big Block 3/8"
- FGL690569 6 Cyl. 5/16" Fuel Line
- FGL690769 V-8 All, 3/8" Fuel Line
- FGL7001 .. 70-73 ... 3/8" Main Fuel Line
- FGL7006 .. 70-74 ... V-6 3/8" Main Line
- FGL740174 3/8" Main Line
- FGL7506 .. 75-76 ... 3/8" Main Fuel Line
- FGL770577 Front 5/16" X-Over

ADD "S" TO PART NUMBER FOR STAINLESS STEEL

- FGL7801 .. 77-79 ... 3/8" Main Fuel Line
- FGL8001 .. 80-81 ... Except Z-28, 3/8" Main
- FGL8005 .. 80-81 ... Z-28, 3/8" Main Line
- FGL8203 .. 82-84 ... 3/8" Main Fuel Line, RH
- FGL8503 .. 85-91 ... 3/8" Main Fuel Line,
For Carbureted Cars, LH
- FGL8506 .. 85-91 ... 3/8" Main Line, Fuel Filter
Forward To Rubber Hose
- FGL8507 .. 85-91 ... 3/8" Main Line, Fuel Filter
Back to Tank
- FGL8508 .. 85-91 ... 3/8" Main Line From Rubber
Hose to Fuel Rail
- FGL930193 V6 3/8" Main Feed To Fuel Filter

RETURN FUEL LINES

Return lines carry excess fuel from fuel pump or fuel filter back to the tank. Not all vehicles were equipped with a return line. They are typically made of 1/4" diameter tubing. Multiple piece sets are noted.

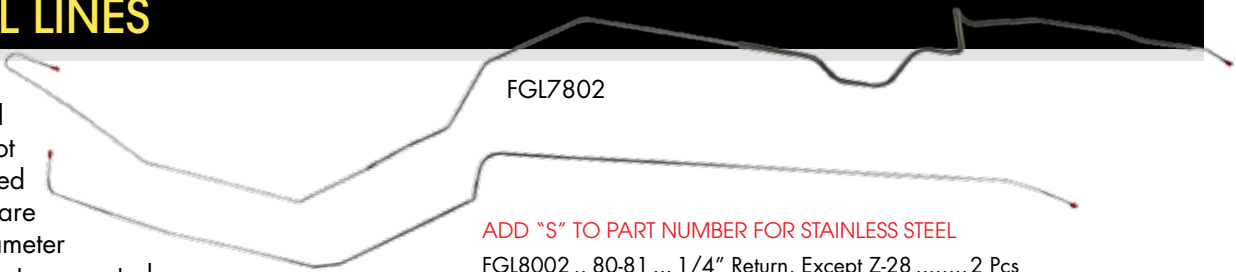

ADD "S" TO PART NUMBER FOR STAINLESS STEEL

- FGL690969 1/4" Fuel Return, V8
- FGL7002 .. 70-73 ... 1/4" Return Line
- FGL740274 1/4" Return Line
- FGL7504 .. 75-76 ... 1/4" Return Line
- FGL7802 .. 77-79 ... 1/4" Return Line

ADD "S" TO PART NUMBER FOR STAINLESS STEEL

- FGL8002 .. 80-81 ... 1/4" Return, Except Z-28 2 Pcs
- FGL8006 .. 80-81 ... Z-28, 1/4" Return Line 2 Pcs
- FGL8204 .. 82-84 ... 1/4" Return Line, LH
- FGL8205 .. 82-84 ... 5/16" Return Line, RH
- FGL8505 .. 85-91 ... 5/16" Return Line, Carb, LH
- FGL8510 .. 85-91 ... 5/16" Return line
- FGL8512 .. 85-91 ... 1/4" Return Line, RH
- FGL930293 5/16" Fuel Return, V6

FUEL LINE CLIPS

Fuel line clips hold tubing to the frame or body of the car. Fasteners are included as noted. See page 284-285 for individual clips.



- FCS003 67-68 ... with 3/8" Fuel Line, No Return 7 Pcs
- FCS00469 with 3/8" Fuel Line, No Return 7 Pcs.
- FCS00569 with 3/8" Fuel & 1/4" Ret. 7 Pcs
- FCS014 75-81 ... Complete Brake & Fuel with Bolts 32 Pcs

FUEL HOSE KITS

These small rubber hoses and clips are used to connect fuel lines to the fuel pump and sending unit.



- FHK3800.... ALL 3/8" x 6", 3/8" x 13", + 4 Green Clamps
- FHK1438.... ALL 3/8" x 6", 3/8" x 13", 1/4" x 18" + 4 Green,
Clamps and 4 Red Clamps



CAMARO FUEL TANKS

FUEL TANKS

Fuel tanks are constructed of Ni-Terne steel. Hardware is not included.



- FFT6701 67-68 Camaro, No Filler Neck
- FST6701 67-68 Camaro, No Filler Neck w/Straps
- FFT6901 69 Camaro
- FST6901 69 CamarowithStraps
- FFT7001 70-73 Camaro without ECS
- FST7001 70-73 Camaro without ECS, with Straps
- FFT7103 71-73 Camaro with ECS, 3 Vents on Front
- FST7103 71-73 Camaro with ECS, 3 Vents on Front, w/Straps
- FFT7401 74-77 Camaro
- FST7401 74-77 Camaro with Straps
- FFT7801 78-81 Camaro
- FST7801 78-81 Camaro with Straps
- FFT8202 82-92 Camaro, EFI
- FST8202 82-92 Camaro, EFI with Straps

SENDING UNITS

Sending units include floats, gaskets and snap rings where applicable. Our fuel senders are made of stainless steel and operate on the same ohm range as factory gauges.

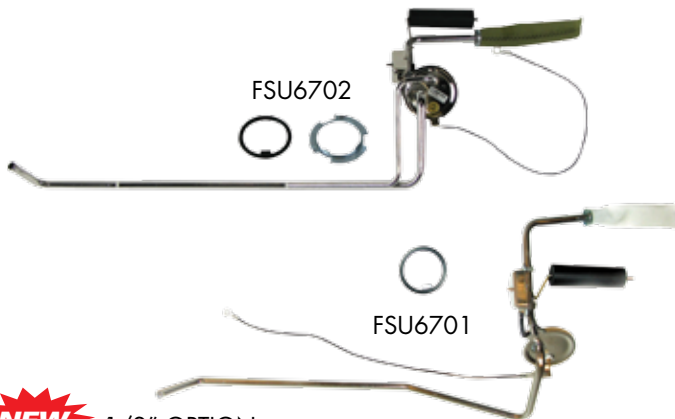

NEW 1/2" OPTION

- FSU670167-69... 3/8" Main
- FSU672167-69... 1/2" Main
- FSU670267-69... 3/8" Main & 1/4" Return
- FSU672267-69... 1/2" Main & 1/4" Return
- FSU700170-73... 3/8" Main
- FSU702170-73... 1/2" Main
- FSU760176-81... 3/8" Main
- FSU760276-81... 3/8" Main & 1/4" Return

TRANSMISSION COOLER LINES

Transmission cooler lines are sold as pairs. Be sure to verify the type of transmission in your project before ordering. These lines are intended to work only with factory motor, transmission, and radiator combinations.

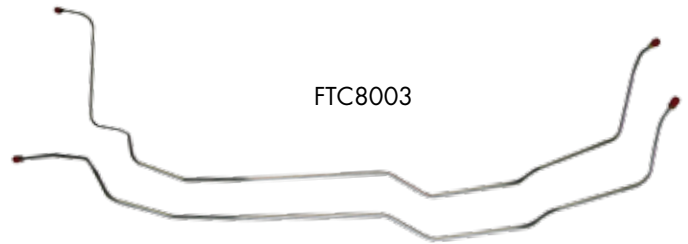

ADD "S" TO PART NUMBER FOR STAINLESS STEEL

- FTC6701 .. 67-69 ... Powerglide, 2 Line Set
- FTC6703 .. 67-69 ... T-350, 2 Line Set
- FTC6705 .. 67-69 ... T-400, 2 Line Set
- FTC6708 .. 67-69 ... 700R, 2 Line Set
- FTC7005 .. 70-74 ... T-400, 2 Line Set, 1/2" Fitting at Rad
- FTC7006 .. 70-74 ... T-400, 2 Line Set, 5/8" Fitting at Rad
- FTC8003 .. 70-74 ... T-350
- FTC860186 T-350

TRANSMISSION VACUUM LINES

Transmission vacuum lines connect automatic transmissions to intake vacuum.



ADD "S" TO PART NUMBER FOR STAINLESS STEEL

- FTV6703 .. 67-68 ... T-350, Left Side Modulator
- FTV6701 .. 67-69 ... Powerglide
- FTV6705 .. 67-69 ... T-400
- FTV6903 .. 67-69 ... with Turbo 350, Right Side Modulator
- FTV700570 with Turbo 400
- FTV740174 Z-28
- FTV7801 .. 78-81 ... with Turbo 350

DISTRIBUTOR VACUUM LINES

Distributor vacuum lines supply intake vacuum to the distributor for timing control.



ADD "S" TO PART NUMBER FOR STAINLESS STEEL

- FDV6605 .. 66-69 ... Big Block with Holley Carburetor
- FDV6701 .. 67-68 ... 6 Cylinder
- FDV6703 .. 67-69 ... Small Block, V-8, 4 BBL Quadrajjet
- FDV6705 .. 67-69 ... Big Block, V-8, 4 BBL Quadrajjet
- FDV67ZZ .. 67-69 ... Z-28
- FDV6707 .. 67-72 ... Small Block, V-8, 2 BBL

SUSPENSION COMPONENTS

UPPER & LOWER BALL JOINTS

COMING IN 2017



XK5103 XK5108

- XK5103.....67-69... Lower
- XK5108.....67-69... Upper
- XK6145.....70-02... Lower
- XK5208.....70-81... Upper

SWAY BAR LINK KITS



XK6217 Cost

- XK6217.....67-69... All
- XK5252.....70-02... All

UPPER & LOWER CONTROL ARM BUSHING KITS



XK6076 XK5196

- XK6076.....67-72... Lower
- XK5196.....67-69... Upper
- XK6108.....70-73... Upper
- XK6109.....73-81... Lower
- XK6144.....74-79... Upper

IDLER ARMS

COMING IN 2017



FIA6701

- FIA6701..... 67 Idler Arm
- FIA6801.....68-69... Idler Arm
- FIA7001.....70-81... Idler Arm

POWER STEERING LINES

Power steering lines can be either pressure or return feeds in a power steering system.



FPH6901

APH6001

ADD "S" TO PART NUMBER FOR STAINLESS STEEL

- FPS6701... 67-68 ... V8, Small Block High Pressure Line
- FPH6901.....69 V8, Small Block High Pressure Line
- FPS7002... 70-72 ... V8, Small Block High Pressure Line
- FPS7301... 73-76 ... V8, Small Block High Pressure Line
- FPS7501.....75 P.S. Low Pressure Line
- FPS8201... 82-85 ... Line Under Core Support
- FPS8601... 86-92 ... Cooler Line
- APH6001 .. N/A..... Power Steering Return Hose Kit

INNER & OUTER TIE RODS & SLEEVES



XE5350S

XES681N

COMING IN 2017

- XES681N 67-69Inner
- XES381RL 67-69Outer
- XES350S..... 67-69Adjusting Sleeve
- XDS781 70-74Inner, Pass Side
- XDS782..... 70-74Inner, Driver Side
- XES404RL 70-74Outer
- XES2004S 70-81Adjusting Sleeve
- XES442L..... 75-79Inner, Driver Side
- XES443L..... 75-79Inner, Pass Side
- XES441RL 75-79Outer
- XES441RL 80-81Outer, 8 cyl
- XES442L..... 80-81Inner, Driver Side, 8 cylinder
- XES443L..... 80-81Inner, Pass Side, 8 cylinder
- XES2001L..... 80-81Inner, Driver Side, 6 cylinder
- XES2002L..... 80-81Inner, Pass Side, 6 cylinder
- XES427R 80-81Outer, 6 cyl
- XES2032S 82-91Adjusting Sleeve

STEERING ARMS



- DBSA0267-69... Steering Arms, 1/2" Bolt Holes (pr)

SWAY BAR BUSHINGS

COMING IN 2017

- XK5227... 67-69 ... All
- XK5253... 70-75 ... 1" or Larger Bar
- XK5241... 70-75 ... 15/16" or Smaller
- XK5241... 76-81 ... 15/16" or Smaller, with Tabs on Mounting Clamp
- XK6161... 76-81 ... 1 to 1 1/8" Bar, with Tabs on Mounting Clamp
- XK5288... 76-91 ... 1-1/16" Bar, without Tabs on Mounting Clamp
- XK6451... 76-91 ... 1" Bar without Tabs on Mounting Clamp
- XK6453... 76-91 ... 1-1/8" Bar without Tabs on Mounting Clamp
- XK5248... 76-91 ... 1-3/16" without Tabs on Mounting Clamp
- XK6455... 76-91 ... 1-1/4" Bar without Tabs on Mounting Clamp
- XK6457... 76-91 ... 1-5/16" Bar without Tabs on Mounting Clamp
- XK6459... 76-91 ... 1-7/16" Bar without Tabs on Mounting Clamp

PITMAN ARM

- FPA670167-69... Pitman Arms



CAMARO FRONT BRAKE CONVERSIONS

**STREET
SERIES**

FRONT DISC BRAKE CONVERSION KITS

U.S.A. Made
TIMKEN Bearings

FRONT CONVERSIONS INCLUDE:

- 11" Rotors
- Forged Spindles (OE or 2" Drop)
- Timken Bearings
- New Calipers
- Caliper Brackets
- Organic Pads
- Backing Plates
- Flex Hoses & Clips
- Valve Bracket & Hardware
- Banjo Bolts & Copper Washers
- Dust Caps
- Castle Nuts & Pins
- Washers
- Grease Seals
- Spindle Gaskets
- Steering Arm Bolts
- Master Cylinder
- Combination Valve
- Pedal Rod Extension
- Brake Switch Pigtail

WORKS WITH FACTORY 14" OR LARGER DISC BRAKE WHEELS

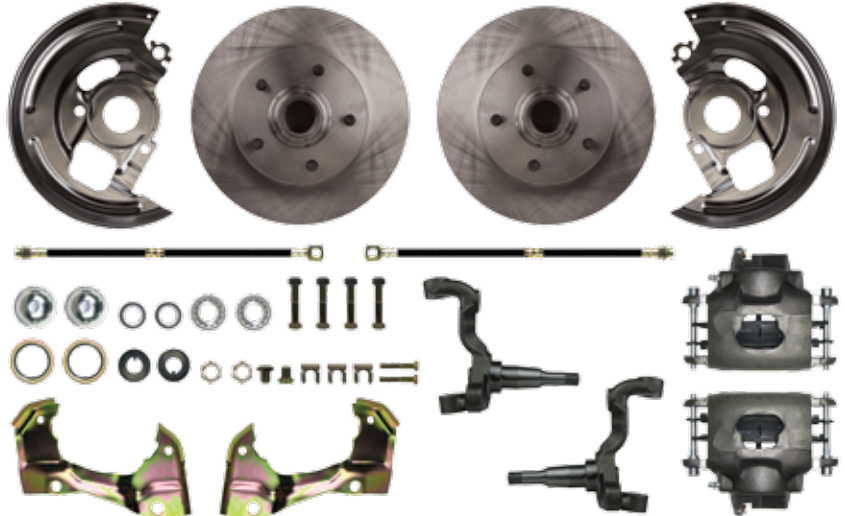

Right Stuff disc conversions are the most complete kits in the industry at the right price. High quality components, professional packaging, and after-sale support by "hands-on" technicians create an unbeatable value. Consider one of our complete brake line packages for a carefree installation.



Packages include At-the-Wheel Disc Conversion Kit & Master Cylinder with Valve (Manual) or Master Cylinder with Booster and Valve (Power).

POWER PACKAGE

MANUAL PACKAGE

11" inch booster, Call for other diameters

AT-THE-WHEEL FRONT KITS

HEIGHT FRONT KITS

- AFXWK02C...67-69.... At-the-Wheel Disc Conversion Kit
- AFXSD02C.....67-69.... Manual Disc Conversion Package
- AFXDC02C....67-69.... Power Disc Conversion Package

2" DROP FRONT KITS

- AFXWK02D ...67-69.... 2" Drop At-the-Wheel Disc Conversion Kit
- AFXSD02D.....67-69.... 2" Drop Manual Disc Conversion Package
- AFXDC02D67-69.... 2" Drop Power Disc Conversion Package

UPGRADES

The next page offers upgrades to fully customize your conversion kit.

SUSPENSION KITS

Standard rubber kits meet O.E. specifications. Polyurethane kits provide better handling and a firmer ride. Poly kits include upgraded control arm bushings, sway bar bushings, and sway bar links. Pre-packaged kits offer huge savings over individual suspension parts. Most kits include the following:

- Lower Ball Joints (2)
- Upper Ball Joints (2)
- Lower Ctrl. Arm Bushings (4)
- Upper Ctrl. Arm Bushings (4)
- Inner Tie Rods (2) (Extra Value)
- Sway Bar Link Kits (2)
- Tie Rod Adj. Sleeves (2)
- Sway Bar Bushings (2)
- Outer Tie Rods (2)

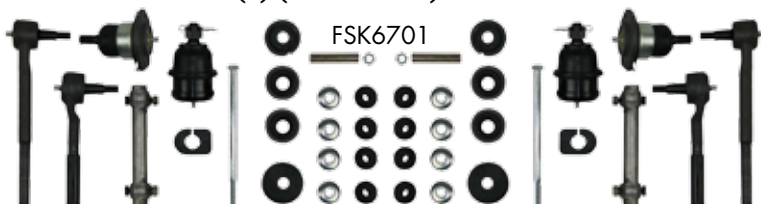

**COMING
IN 2017**

- FSK670167-69... Front Rebuild Kit, 22-Piece
- FSK6701U...67-69... Front Rebuild Kit, 22-Piece - (Poly)
- FSK700170-72... Front Rebuild Kit, 24-Piece
- FSK730173 Front Rebuild Kit, 24-Piece
- FSK740174 Front Rebuild Kit, 24-Piece
- FSK750175 Front Rebuild Kit, 24-Piece
- FSK760176-79... Front Rebuild Kit, 26-Piece with 15/16, 1-1/8", & 1-3/16" Sway Bar with Tabs on Mounting Clamps
- FSK760276-79... Front Rebuild Kit, 24-Piece with 1" & 1-1/16" Sway Bar without Tabs on Mounting Clamps
- FSK760376-79... Front Rebuild Kit, 24-Piece with 1-1/8" & 1-3/16" Sway Bar without Tabs on Mounting Clamps
- FSK760476-79... Front Rebuild Kit, 26-Piece with 1-1/4, 1-5/16", & 1-7/16" Sway Bar without Tabs on Mounting Clamps

CAMARO FRONT BRAKE UPGRADES

FRONT DISC BRAKE CONVERSION UPGRADES

STREET SERIES

SHOW'N GO UPGRADE TRIM KITS

These At-the-Wheel Disc Conversion Kits (stock height or 2" drop) include upgraded drilled slotted rotors with zinc plating, powder coated calipers in red or black, and braided stainless hoses.



STOCK HEIGHT SHOW'N GO

AFXWK02CS ...67-69.... At-the-Wheel Disc Conversion Kit - Black
 AFXWK02CZ ...67-69.... At-the-Wheel Disc Conversion Kit - Red
 AFXSD02CS.....67-69.... Manual Disc Conversion Package - Black
 AFXSD02CZ.....67-69.... Manual Disc Conversion Package - Red
 AFXDC02CS67-69.... Power Disc Conversion Package - Black
 AFXDC02CZ67-69.... Power Disc Conversion Package - Red

2" DROP SHOW'N GO

AFXWK02DS ...67-69...2" Drop At-the-Wheel Disc Conv Kit - Black
 AFXWK02DZ ...67-69...2" Drop At-the-Wheel Disc Conv Kit - Red
 AFXSD02DS.....67-69...2" Drop Manual Disc Conversion Pkg - Black
 AFXSD02DZ.....67-69...2" Drop Manual Disc Conversion Pkg - Red
 AFXDC02DS67-69...2" Drop Power Disc Conversion Pkg - Black
 AFXDC02DZ67-69...2" Drop Power Disc Conversion Pkg - Red

SHOW STOPPER TRIM PACKAGES

Includes At-the-Wheel Front Disc Conversion Kit (stock height or 2" drop) with natural finish calipers. The Manual Packages get an upgraded chrome plated master cylinder and combination valve with bracket. Power Packages include an upgraded 8" dual chrome booster.



STOCK HEIGHT SHOW STOPPER

AFXSD02CX..... 67-69Manual Disc Conversion Package
 AFXDC02CX 67-69Power Disc Conversion Package

2" DROP SHOW STOPPER

AFXSD02DX..... 67-69 2" Drop Manual Disc Conv Package
 AFXDC02DX 67-69 2" Drop Power Disc Conv Package

BEST OF SHOW TRIM PACKAGES

Includes At-the-Wheel Front Disc Conversion Kit (stock height or 2" drop) with black or red calipers, drilled & slotted rotors & braided stainless hoses. The Manual Packages get an upgraded chrome plated master cylinder and combination valve with bracket. Power Packages include an upgraded 8" dual chrome booster.

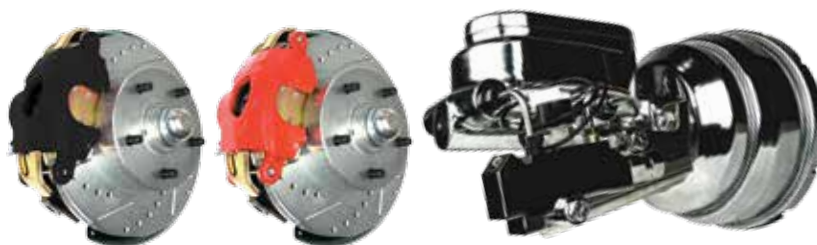

STOCK HEIGHT BEST OF SHOW

AFXSD02CSX.... 67-69 Manual Disc Conversion Package - Black
 AFXSD02CZX.... 67-69 Manual Disc Conversion Package - Red
 AFXDC02CSX ... 67-69 Power Disc Conversion Package - Black
 AFXDC02CZX ... 67-69 Power Disc Conversion Package - Red

2" DROP BEST OF SHOW

AFXSD02DSX ... 67-69 ...2" Drop Manual Disc Conv Package - Blk
 AFXSD02DZX... 67-69 ...2" Drop Manual Disc Conv Package - Red
 AFXDC02DSX... 67-69 ...2" Drop Power Disc Conv Package - Black
 AFXDC02DZX .. 67-69 ...2" Drop Power Disc Conv Package - Red



Disc Brake Conversions require special brake lines that fit your new disc conversion setup. Right Stuff offers "No Brainer" Brake Line Kits that include all components needed from your master cylinder back to your rear wheel cylinder or calipers. They include front brake line kit, front to rear line, rear axle lines & flex hose, & clip set.

See page 26 for your application

CAMARO 4-WHEEL BRAKE CONVERSIONS

**STREET
SERIES**

FOUR WHEEL DISC BRAKE CONVERSION KITS

U.S.A. Made
TIMKEN Bearings

FRONT CONVERSIONS INCLUDE:

- 11" Rotors
- Forged Spindles (OE or 2" Drop)
- Timken Bearings
- New Calipers
- Caliper Brackets
- Organic Pads
- Backing Plates
- Flex Hoses & Clips
- Valve Bracket & Hardware
- Banjo Bolts & Copper Washers
- Dust Caps
- Castle Nuts & Pins
- Washers
- Grease Seals
- Spindle Gaskets
- Steering Arm Bolts
- Master Cylinder
- Combination Valve
- Pedal Rod Extension
- Brake Switch Pigtail

REAR CONVERSIONS INCLUDE:

- 11" Rotors
- Caliper Brackets & Spacers
- Weld-On Hose Brackets
- Flex Hoses
- Backing Plates (Exclusive), not for AFXRD78 or AFXRDM78
- New Loaded Caliper
- E-Brake Cables
- Hardware

Right Stuff disc conversions are the most complete kits in the industry at the right price. High quality components, professional packaging, and after-sale support by "hands-on" technicians create an unbeatable value. Consider one of our complete brake line packages for a carefree installation. See page 21 to verify axle flange measurements for these kits.



Packages include At-the-Wheel Disc Conversion Kits & Master Cylinder with Valve (Manual) or Master Cylinder with Booster and Valve (Power).

POWER PACKAGE

MANUAL PACKAGE

WORKS WITH 15" AND LARGER WHEELS

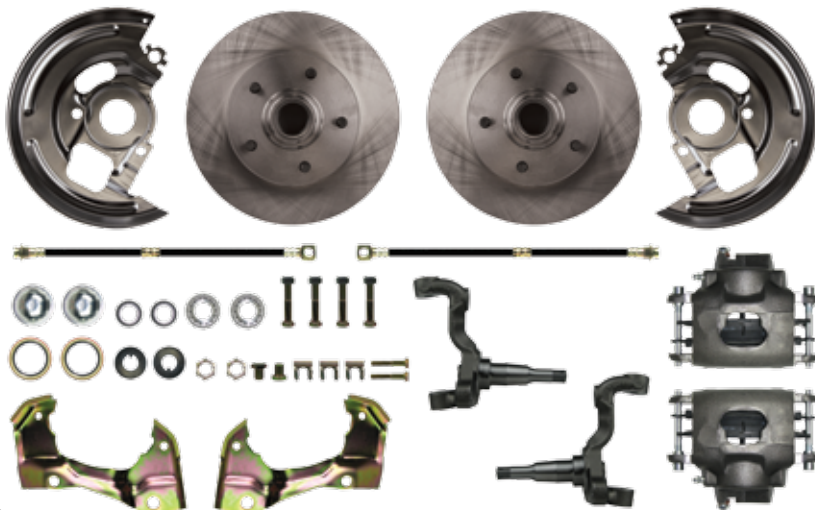

AT-THE-WHEEL FRONT KIT

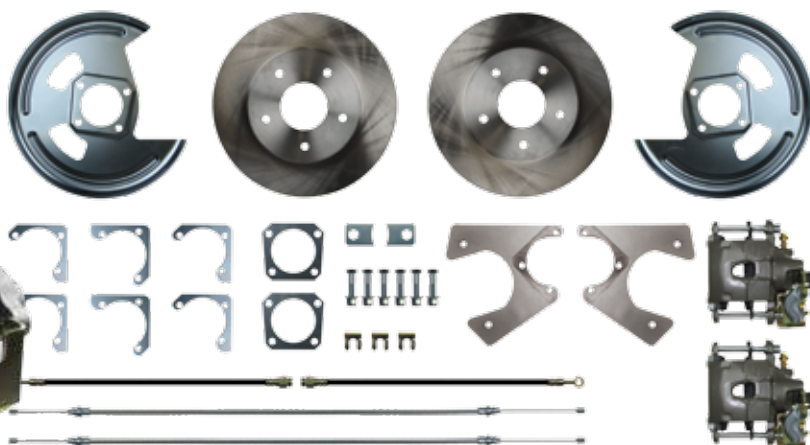

AT-THE-WHEEL REAR KIT

6-3/16" INSIDE ROTOR DIAMETER - 2.78" CENTER HOLE

STOCK HEIGHT 4-WHEEL KITS

- AFXSD42C.....67 Manual Disc Brake Conv Pkg - Non-Staggered
- AFXDC42C....67 Power Disc Brake Conv Pkg - Non-Staggered
- AFXSD45C...68-69.. Manual Disc Conv Package - Staggered
- AFXDC45C..68-69.. Power Disc Conv Package - Staggered

2" DROP 4-WHEEL KITS

- AFXSD42D67 2" Drop Manual Disc Brake Conv Pkg - Non-Stag
- AFXDC42D.....67 2" Drop Power Disc Brake Conv Pkg - Non-Stag
- AFXSD45D .. 68-69.. 2" Drop Manual Disc Conv Pkg - Staggered
- AFXDC45D.. 68-69.. 2" Drop Power Disc Conv Pkg - Staggered



UPGRADES

The next page offers upgrades to fully customize your conversion kit.

CAMARO 4-WHEEL BRAKE UPGRADES

4-WHEEL DISC BRAKE CONVERSION UPGRADES

STREET SERIES

SHOW'N GO UPGRADE TRIM KITS

These At-the-Wheel Disc Conversion Kits (stock height or 2" drop) include upgraded drilled slotted rotors with zinc plating, powder coated calipers in red or black, and braided stainless hoses.



STOCK HEIGHT SHOW'N GO

AFXSD42CS....67.....Manual Disc Conv Pkg - Non-Staggered - Black
 AFXSD42CZ....67.....Manual Disc Conv Pkg - Non-Staggered - Red
 AFXDC42CS...67.....Power Disc Conv Pkg 11" Booster - Non-Stagg - Blk
 AFXDC42CZ...67.....Power Disc Conv Pkg 11" Booster - Non-Stag - Red
 AFXSD45CS..68-69..Manual Disc Conv Pkg - Staggered - Black
 AFXSD45CZ..68-69..Manual Disc Conversion Package - Stagg - Red
 AFXDC45CS..68-69..Power Disc Conv Pkg 11" Booster - Staggered - Blk
 AFXDC45CZ..68-69..Power Disc Conv Pkg 11" Booster - Staggered - Red

2" DROP SHOW'N GO

AFXSD42DS...67...2" Drop Manual Disc Conv Pkg - Non-Staggered - Blk
 AFXSD42DZ...67...2" Drop Manual Disc Conv Pkg - Non-Staggered - Red
 AFXDC42DS...67...2" Drop Pwr Disc Conv Pkg 11" Booster, Non-Stag - Blk
 AFXDC42DZ...67...2" Drop Pwr Disc Conv Pkg 11" Booster, Non-Stag - Red
 AFXSD45DS..68-69..2" Drop - Manual Disc Conv Pkg - Staggered - Blk
 AFXSD45DZ..68-69..2" Drop - Manual Disc Conv Pkg - Staggered - Red
 AFXDC45DS..68-69..2" Drop Pwr Disc Conv Pkg, 11" Booster - Stagg - Blk
 AFXDC45DZ..68-69..2" Drop Pwr Disc Conv Pkg, 11" Booster - Stagg - Red

SHOW STOPPER TRIM PACKAGES

Includes At-the-Wheel Front Disc Conversion Kit (stock height or 2" drop) with natural finish calipers. The Manual Packages get an upgraded chrome plated master cylinder and combination valve with bracket. Power Packages include an upgraded 8" dual chrome booster.

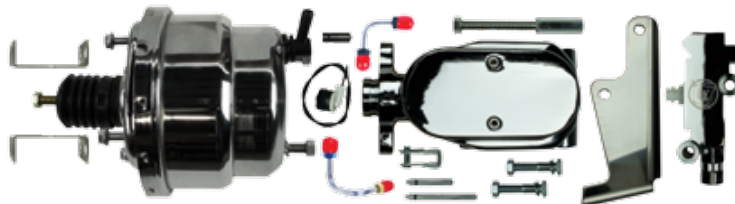

STOCK HEIGHT SHOW STOPPER

AFXSD42CX.....67.....Manual Disc Brake Conv Pkg - Non-Staggered
 AFXDC42CX.....67.....Power Disc Brake Conv Pkg - Non-Staggered
 AFXSD45CX..68-69..Manual Disc Conv Package - Staggered
 AFXDC45CX..68-69..Power Disc Conv Package - Staggered

2" DROP SHOW STOPPER

AFXSD42DX....67...2" Drop Manual Disc Brake Conv Pkg - Non-Stag
 AFXDC42DX...67...2" Drop Power Disc Brake Conv Pkg - Non-Stag
 AFXSD45DX...68-69..2" Drop Manual Disc Conv Pkg - Staggered
 AFXDC45DX..68-69..2" Drop Power Disc Conv Pkg - Staggered

BEST OF SHOW TRIM PACKAGES

Includes At-the-Wheel Front Disc Conversion Kit (stock height or 2" drop) with black or red calipers, drilled & slotted rotors & braided stainless hoses. The Manual Packages get an upgraded chrome plated master cylinder and combination valve with bracket. Power Packages include an upgraded 8" dual chrome booster.



STOCK HEIGHT BEST OF SHOW

AFXSD42CSX.....67...Manual Disc Conv Pkg - Black, Non-Stagg
 AFXSD42CZX....67...Manual Disc Conv Pkg - Red, Non-Stagg
 AFXDC42CSX....67...Power Disc Conv Pkg - Black, Non-Staggered
 AFXDC42CZX....67...Power Disc Conv Pkg - Red, Non-Staggered
 AFXSD45CSX...68-69..Man Disc Conv Package - Staggered - Black
 AFXSD45CZX..68-69..Man Disc Conv Package - Staggered - Red
 AFXDC45CSX..68-69..Pwr Disc Conv Package - Staggered - Black
 AFXDC45CZX..68-69..Pwr Disc Conv Package - Staggered - Red

2" DROP BEST OF SHOW

AFXSD42DSX...67...2" Drop Manual Disc Conv Pkg - Black, Non-Stag
 AFXSD42DZX...67...2" Drop Manual Disc Conv Pkg - Red, Non-Stag
 AFXDC42DSX..67...2" Drop Power Disc Conv Pkg - Black, Non-Stag
 AFXDC42DZX..67...2" Drop Power Disc Conv Pkg - Red, Non-Stag
 AFXSD45DSX...68-69..2" Drop Man Conv Package - Staggered - Blk
 AFXSD45DZX...68-69..2" Drop Man Conv Package - Staggered - Red
 AFXDC45DSX...68-69..2" Drop Pwr Conv Package - Staggered - Black
 AFXDC45DZX...68-69..2" Drop Pwr Conv Package - Staggered - Red

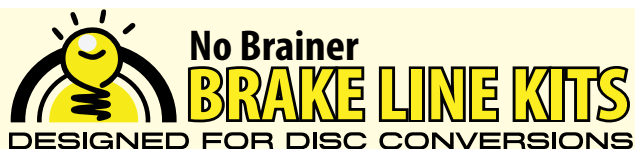

See page 26 for your application

CAMARO REAR BRAKE CONVERSIONS

**STREET
SERIES**

REAR DISC BRAKE CONVERSION KITS

REAR CONVERSIONS INCLUDE:

- 11" Rotors
- Caliper Brackets & Spacers
- Weld-On Hose Brackets
- Flex Hoses
- Backing Plates (Exclusive), not for AFXRD78 or AFXRDM78
- New Loaded Calipers
- E-Brake Cables
- Hardware

Right Stuff disc conversions are the most complete kits in the industry at the right price. High quality components, professional packaging, and after-sale support by "hands-on" technicians create an unbeatable value. Consider one of our complete brake line packages for a carefree installation. **See the next page to verify axle flange measurements for these kits.**

WANT MATCHING FRONT UPGRADES?

SEE THE NEXT PAGE FOR OUR REAR+2 CONVERSIONS

ATTENTION Before you order, be sure to measure the axle flange on your vehicle.

WORKS WITH 15" AND LARGER WHEELS

6-3/16" INSIDE ROTOR DIAMETER - 2.78" CENTER HOLE

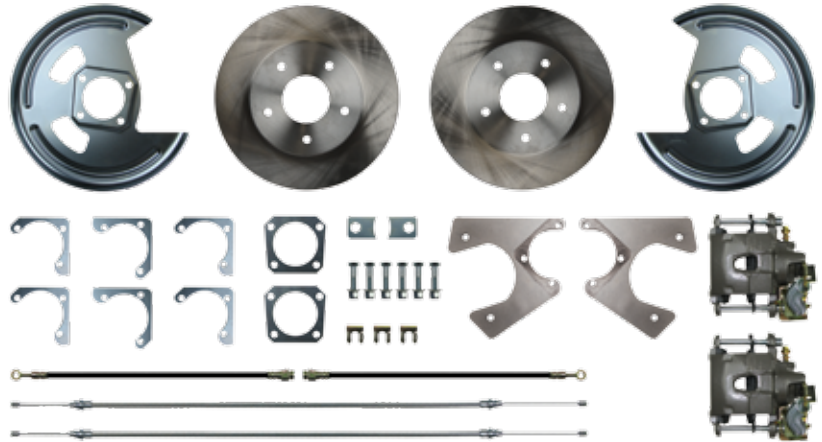

REAR KITS WITH E-BRAKE

- AFXRD01 67 10 & 12 Bolt without Staggered Shocks
- AFXRD05 68-69 ... 10 & 12 Bolt with Staggered Shocks
- AFXRD06 70-74 ... 10 & 12 Bolt with Staggered Shocks
- AFXRD07 75-81 ... 10 & 12 Bolt with Staggered Shocks
- AFXRD82 82-92 ... 10 Bolt without Staggered Shocks

REAR KITS WITHOUT E-BRAKE

- AFXRDM1 67 10 & 12 Bolt without Staggered Shocks
- AFXRDM5 68-69 ... 10 & 12 Bolt with Staggered Shocks
- AFXRDM6 70-74 ... 10 & 12 Bolt with Staggered Shocks
- AFXRDM7 75-81 ... 10 & 12 Bolt with Staggered Shocks
- AFXRDM78 .. 82-92 ... 10 Bolt without Staggered Shocks

REAR DISC BRAKE CONVERSION UPGRADES

**STREET
SERIES**

SHOW'N GO UPGRADE TRIM PACKAGES

These Rear Disc Conversion Kits include upgraded drilled slotted rotors with zinc plating, powder coated calipers in red or black, and braided stainless hoses.



REAR UPGRADE WITH E-BRAKE

- AFXRD01S 67 10 & 12 Bolt w/o Staggered Shocks - Black
- AFXRD01Z 67 10 & 12 Bolt w/o Staggered Shocks - Red
- AFXRD05S ... 68-69 ... 10 & 12 Bolt with Staggered Shocks - Black
- AFXRD05Z ... 68-69 ... 10 & 12 Bolt with Staggered Shocks - Red
- AFXRD06S ... 70-74 ... 10 & 12 Bolt with Staggered Shocks - Black
- AFXRD06Z ... 70-74 ... 10 & 12 Bolt with Staggered Shocks - Red
- AFXRD07S ... 75-81 ... 10 & 12 Bolt with Staggered Shocks - Black
- AFXRD07Z ... 75-81 ... 10 & 12 Bolt with Staggered Shocks - Red
- AFXRD82S ... 82-92 ... 10 Bolt without Staggered Shocks - Black
- AFXRD82Z ... 82-92 ... 10 Bolt without Staggered Shocks - Red

REAR UPGRADE W/O E-BRAKE

- AFXRDM1S 67 10 & 12 Bolt w/o Staggered Shocks - Black
- AFXRDM1Z 67 10 & 12 Bolt w/o Staggered Shocks - Red
- AFXRDM5S ... 68-69 .. 10 & 12 Bolt with Staggered Shocks - Black
- AFXRDM5Z ... 68-69 .. 10 & 12 Bolt with Staggered Shocks - Red
- AFXRDM6S ... 70-74 .. 10 & 12 Bolt with Staggered Shocks - Black
- AFXRDM6Z ... 70-74 .. 10 & 12 Bolt with Staggered Shocks - Red
- AFXRDM7S ... 75-81 .. 10 & 12 Bolt with Staggered Shocks - Black
- AFXRDM7Z ... 75-81 .. 10 & 12 Bolt with Staggered Shocks - Red
- AFXRDM82S .. 82-92 .. 10 Bolt without Staggered Shocks - Black
- AFXRDM82Z .. 82-92 .. 10 Bolt without Staggered Shocks - Red

CAMARO REAR +2 BRAKE CONVERSIONS

**STREET
SERIES**

REAR +2 DISC BRAKE CONVERSION KITS

REAR +2 CONVERSIONS INCLUDE:

- 11" Drilled-Slotted-Zinc Rear Rotors
- Black or Red Rear Powder Coated Calipers
- Caliper Brackets, Spacers, Hardware
- Braided Stainless Rear Hoses
- Weld-On Hose Brackets
- Backing Plates *TRSD Exclusive
- E-Brake Cables

+2 KITS ALSO INCLUDE

- Drilled-Slotted-Zinc Front Rotors
- Black or Red Powder Coated Front Calipers
- Braided Stainless Front Hoses

Right Stuff disc conversions are the most complete kits in the industry at the right price. High quality components, professional packaging, & after-sale support by "hands-on" technicians creates an unbeatable value. Get a rear conversion & matching front upgrades with a single part number.



FRONT ROTORS
DRILLED & SLOTTED

NOTE:
FITS FACTORY
REAR ENDS
CALL FOR CUSTOM
APPLICATIONS

WORKS WITH 15" AND LARGER WHEELS

REAR DISC BRAKES + MATCHING FRONT UPGRADES
6-3/16" INSIDE ROTOR DIAMETER - 2.78" CENTER HOLE

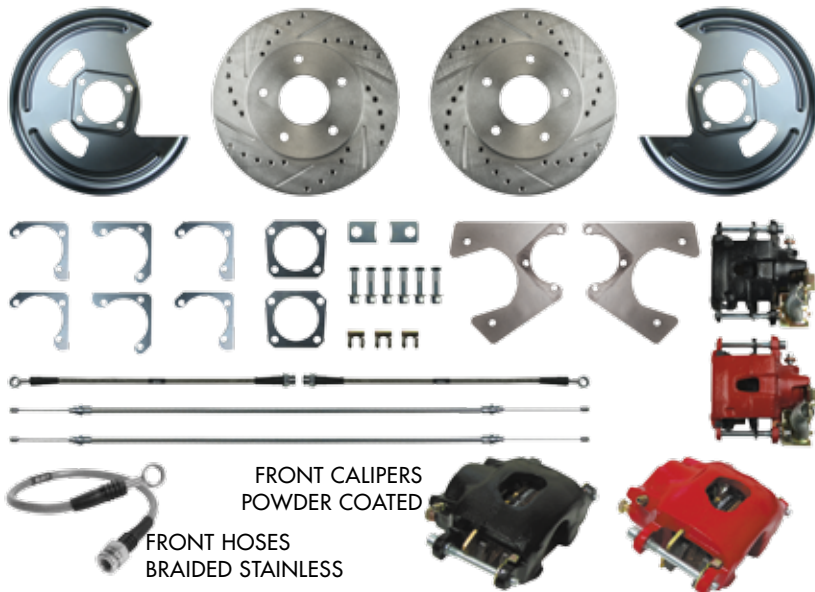

FRONT CALIPERS
POWDER COATED

FRONT HOSES
BRAIDED STAINLESS

REAR +2 KITS WITH E-BRAKE

- F69RD05S 69 Black Calipers, Drilled/Slotted
- F69RD05Z 69 Red Calipers, Drilled/Slotted
- F70RD06S 70-74 Black Calipers, Drilled/Slotted
- F70RD06Z 70-74 Red Calipers, Drilled/Slotted
- F75RD07S 75-77 Black Calipers, Drilled/Slotted
- F75RD07Z 75-77 Red Calipers, Drilled/Slotted
- F78RD07S 78 Black Calipers, Drilled/Slotted
- F78RD07Z 78 Red Calipers, Drilled/Slotted
- F79RD07S 79-81 Black Calipers, Drilled/Slotted
- F79RD07Z 79-81 Red Calipers, Drilled/Slotted
- F82RD78S 82-87 Black Calipers, Drilled/Slotted
- F82RD78Z 82-87 Red Calipers, Drilled/Slotted

REAR +2 KITS WITHOUT E-BRAKE

- F69RDM5S 69 Black Calipers, Drilled/Slotted
- F69RDM5Z 69 Red Calipers, Drilled/Slotted
- F70RDM5S 70-77 Black Calipers, Drilled/Slotted
- F70RDM5Z 70-77 Red Calipers, Drilled/Slotted
- F75RDM5S 75-77 Black Calipers, Drilled/Slotted
- F75RDM5Z 75-77 Red Calipers, Drilled/Slotted
- F78RDM5S 78 Black Calipers, Drilled/Slotted
- F78RDM5Z 78 Red Calipers, Drilled/Slotted
- F79RDM5S 79-81 Black Calipers, Drilled/Slotted
- F79RDM5Z 79-81 Red Calipers, Drilled/Slotted
- F82RDM78S 82-87 Black Calipers, Drilled/Slotted
- F82RDM78Z 82-87 Red Calipers, Drilled/Slotted

AXLE FLANGE DIAGRAMS

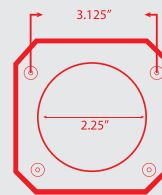
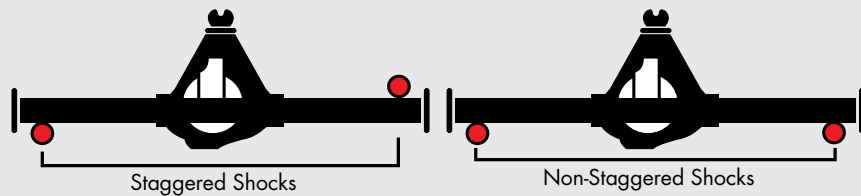

GM

AFXRD01 & AFXRD05
AFXRD06 & AFXRD07

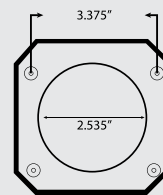

GM

FSCRD01

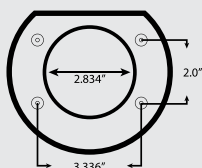

**FORD SMALL
9" or 8"**

ZDCRD02

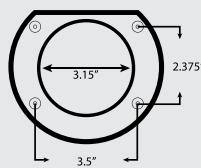

**FORD LARGE 9"
OLDSTYLE**

ZDCRD01 & ZDCRD05

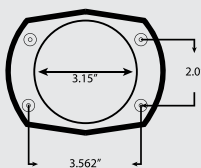

**FORD LARGE 9"
NEW TORINO STYLE**

ZDCRD01 & ZDCRD05

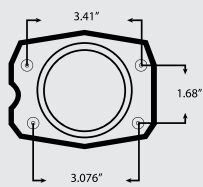

8.8" FORD

ZDCRD03

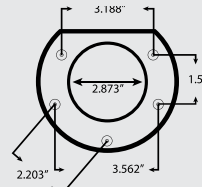

**8 3/4" and 9 3/4"
MOPAR - DANA 60**

MDCRD01

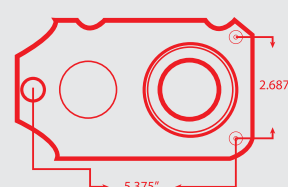

GM
AFXRD78

CAMARO EZ FIT STOCK STYLE CONVERSIONS



BRAKE•KITS

Fits stock 14" wheel. Bolts to stock drum or disc brake spindles. Minimal offset for better fenderwell clearance. Proprietary rotor.

EZ FIT BRAKE CONVERSION KITS

HALF THE INSTALL TIME

KEEP YOUR FACTORY 14" WHEELS

EZ FIT FRONT CONVERSIONS INCLUDE:

- 10" Rotors with Organic Pads
- New Calipers & Brackets
- Banjo Bolts & Copper Washers
- Dust Caps, Castle Nuts & Pins
- Brake Switch Pigtail
- Master Cylinder (Power/Manual Kits)
- Timken Bearings
- Flex Hoses & Kit
- Grease Seals
- Steering Arm Bolts
- Combination Valve
- 9" Booster (Power)

EZ FIT REAR CONVERSIONS INCLUDE:

- Fits 14" wheels
- Uses proprietary rotor
- Built in e-brake (No cables included)

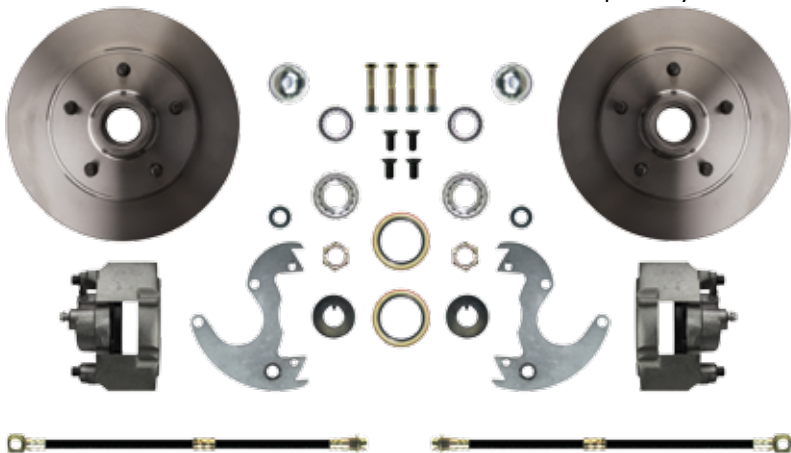

FRONT AT-THE WHEEL KITS

Bolts to your stock drum or disc brake spindles.

Available with standard stock-style rotors or upgraded drilled, slotted & zinc rotors.

FRONT 14" - STANDARD ROTORS

- AFXWK14 67-69 Front At-the-Wheel Disc Conversion Kit
- AFXSD14..... 67-69 Front Manual Disc Conversion Package
- AFXDC14 67-69 Front Power Disc Conversion Package

FRONT 14" - UPGRADE ROTORS

- AFXWK14A 67-69 Front At-the-Wheel Disc Conversion Kit
- AFXSD14A..... 67-69 Front Manual Disc Conversion Package
- AFXDC14A 67-69 Front Power Disc Conversion Package

REAR 14" - STANDARD ROTORS

- AFXRD14..... 67 Rear Kit, Non-Staggered
- AFXRD13 68-69 Rear Kit, Staggered

REAR 14" - UPGRADE ROTORS

- AFXRD14A..... 67 Rear Kit, Non-Staggered
- AFXRD13A..... 68-69 Rear Kit, Staggered



LOOKING FOR A DIFFERENT BOOSTER + MASTER CYLINDER IN YOUR KIT?

Simply purchase At-The-Wheel-Kit above along with any Booster + Master combo on page 11.



Packages include At-the-Wheel Disc Conversion Kits & Master Cylinder with Valve (Manual) or Master Cylinder with Booster and Valve (Power).

POWER PACKAGE

MANUAL PACKAGE



Disc Brake Conversions require special brake lines that fit your new disc conversion setup. Right Stuff offers "No Brainer" Brake Line Kits that include all components needed from your master cylinder back to your rear wheel cylinder or calipers. They include front brake line kit, front to rear line, rear axle lines & flex hose, & clip set.

See page 26 for your application

CAMARO PERFORMANCE SERIES CONVERSIONS

Performance
SERIES

COMPLETE DISC BRAKE CONVERSION KITS

NEW

U.S.A. Made
TIMKEN Bearings

Right Stuff Performance Series disc conversions are the most complete kits in the industry at the right price. Designed for the performance street machine with high quality components, professional packaging, and after-sale support by "hands-on" technicians and many DIY videos at rightstuff create an unbeatable value.

Kits are available as a **Disc Brake Upgrade** that bolts to stock front disc brake spindles, or as an **At-The-Wheel Kit** that includes everything for a front disc brake conversion, and as a **Complete Conversion Kit** which includes everything in the At-The-Wheel Kit with the addition of the master cylinder, booster and prop valve (Power or Manual).

AT-THE-WHEEL CONVERSION KITS INCLUDE:

- 11" Drilled & Slotted Rotors
- Wilwood Dual Piston Calipers
- Caliper Brackets
- Backing Plates
- Timken Bearings
- Castle Nuts & Pins
- Dust Caps
- Forged Spindles
- Organic Pads
- Washers
- Grease Seals
- Spindle Gaskets
- Steering Arm Bolts
- Hardware

COMPLETE CONVERSION KITS ALSO INCLUDE

- Master Cylinder - Chrome or Standard Finish
- Flex Hoses & Clips
- Valve Bracket & Hardware
- Banjo Bolts & Copper Washers
- Combination Valve
- Brake Switch Pigtail
- Pedal Rod Extension



DISC BRAKE UPGRADE KITS INCLUDE (Kit is Designed to Bolt to Stock Disc Brake Spindles)

- Wilwood 2-Piston Aluminum Calipers
- Cross-Drilled & Slotted Zinc Plated Rotors
- Braided Stainless Hoses
- Organic Brake Pads

DISC BRAKE UPGRADE KITS

RCP69S 1969 Black 2-Piston Wilwood Calipers
 RCP69Z 1969 Red 2-Piston Wilwood Calipers
 RCP70S70-78..... Black 2-Piston Wilwood Calipers
 RCP70Z70-78..... Red 2-Piston Wilwood Calipers
 RCP79S79-81..... Black 2-Piston Wilwood Calipers
 RCP79Z79-81..... Red 2-Piston Wilwood Calipers

WORKS WITH 15" AND LARGER WHEELS

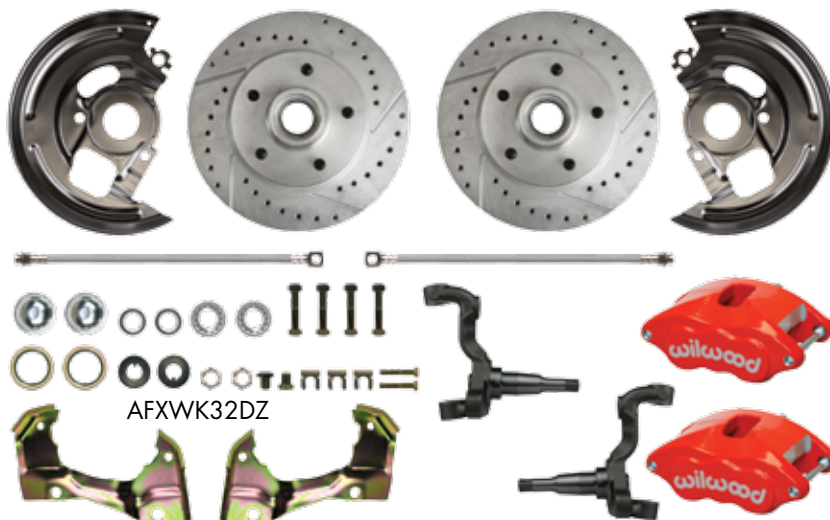

FRONT AT-THE-WHEEL KITS

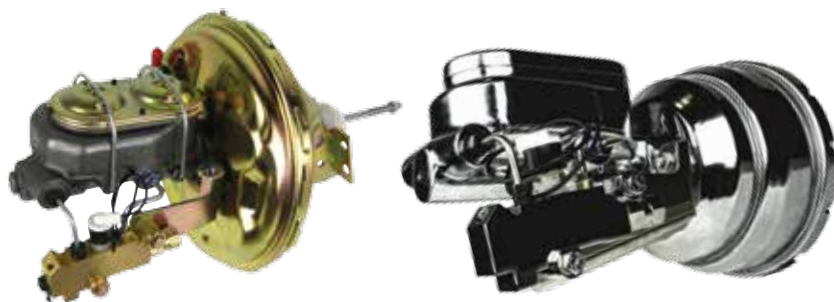

STANDARD PACKAGE

CHROME PACKAGE

Packages include At-the-Wheel Disc Conversion Kits and Chrome or Standard Finish Master Cylinder with Booster and Valve (Power).

STOCK HEIGHT FRONT KITS

AFXWK32S.....67-69 At-The-Wheel Stock Height - Black Wilwood
 AFXWK32Z67-69 At-The-Wheel Stock Height - Red Wilwood
 AFXDC32S.....67-69 Standard Booster/Master - Black Wilwood
 AFXDC32Z67-69 Standard Booster/Master - Red Wilwood
 AFXDC32SX.....67-69 Chrome Booster/Master - Black Wilwood
 AFXDC32ZX.....67-69 Chrome Booster/Master - Red Wilwood

2" DROP FRONT KITS

AFXWK32DS ...67-69....At-The-Wheel 2" Drop - Black Wilwood
 AFXWK32DZ ...67-69....At-The-Wheel 2" Drop - Red Wilwood
 AFXDC32DS67-69....Standard Booster/Master - Black Wilwood
 AFXDC32DZ67-69....Standard Booster/Master - Red Wilwood
 AFXDC32DSX...67-69....Chrome Booster/Master - Black Wilwood
 AFXDC32DZX ..67-69....Chrome Booster/Master - Red Wilwood

CAMARO SIGNATURE SERIES CONVERSIONS



DISC BRAKE CONVERSION KITS

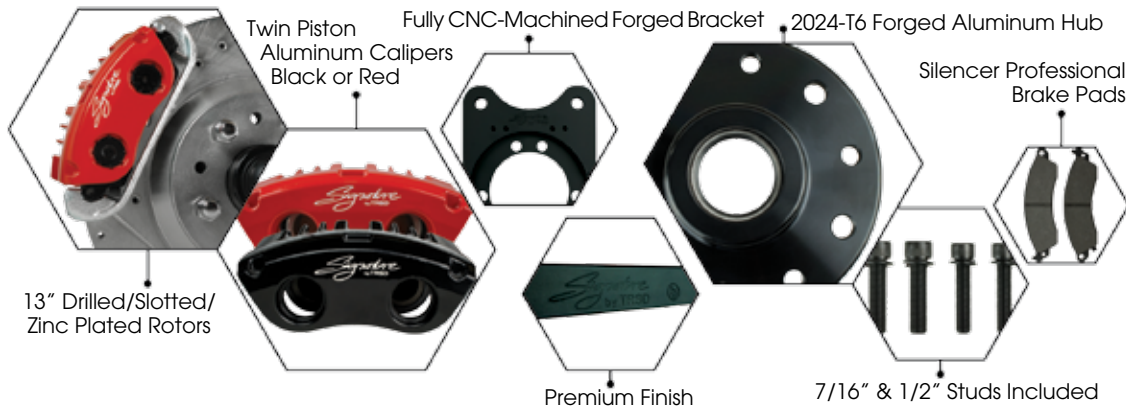

DESIGNED FOR 17\"/>

Bold looks define the Signature Series line of brake kits. Large diameter zinc plated rotors, powder coated calipers, fully machined caliper brackets, & braided stainless brake hoses. Only premium quality components make the grade. We back every kit with industry leading technical support. Signature Series kits are amazing brakes at a great price. Add a No Brainer Brake Line Kit for a true bolt-on install.

SIGNATURE SERIES FRONT KIT

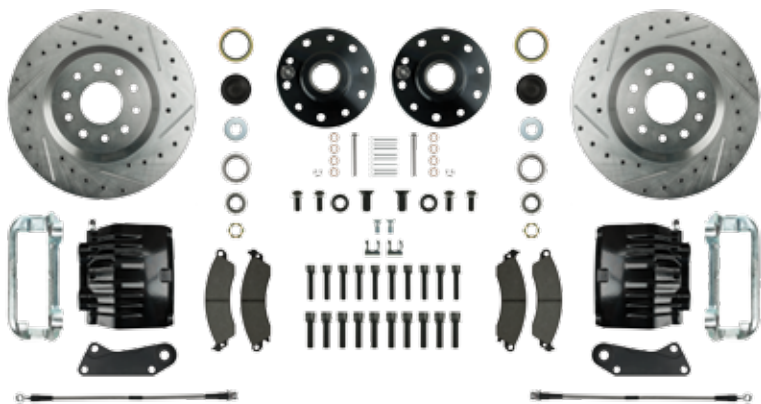

U.S.A. Made **TIMKEN** Bearings



STOCK HEIGHT FRONT KITS

Uses existing drum or disc brake spindles

- AFXWK31CS67-69At-The-Wheel Kit - Black Calipers
- AFXWK31CZ67-69At-The-Wheel Kit - Red Calipers
- AFXSD31CS67-69Manual Kit - Black Calipers
- AFXSD31CZ67-69Manual Kit - Red Calipers
- AFXDC31CS67-69Power Kit - Black Calipers
- AFXDC31CZ67-69Power Kit - Black Calipers

2" DROP FRONT KITS

Includes new 2" drop spindles

- AFXWK31DS67-69At-The-Wheel Kit - Black Calipers
- AFXWK31DZ67-69At-The-Wheel Kit - Red Calipers
- AFXSD31DS67-69Manual Kit - Black Calipers
- AFXSD31DZ67-69Manual Kit - Red Calipers
- AFXDC31DS67-69Power Kit - Black Calipers
- AFXDC31DZ67-69Power Kit - Black Calipers

STOCK HEIGHT 4-WHEEL KITS

Stock Height - Non-Staggered Shocks

- AFXWK51CS 67-69At-The-Wheel Kit - Black Calipers
- AFXWK51CZ 67-69At-The-Wheel Kit - Red Calipers
- AFXSD51CS 67-69Manual Kit - Black Calipers
- AFXSD51CZ 67-69Manual Kit - Red Calipers
- AFXDC51CS 67-69Power Kit - Black Calipers
- AFXDC51CZ 67-69Power Kit - Black Calipers

Stock Height - Staggered Shocks

- AFXWK55CS 67-69At-The-Wheel Kit - Black Calipers
- AFXWK55CZ 67-69At-The-Wheel Kit - Red Calipers
- AFXSD55CS 67-69Manual Kit - Black Calipers
- AFXSD55CZ 67-69Manual Kit - Red Calipers
- AFXDC55CS 67-69Power Kit - Black Calipers
- AFXDC55CZ 67-69Power Kit - Black Calipers

2" DROP 4-WHEEL KITS

2" Drop - Non-Staggered Shocks

- AFXWK51DS67-69At-The-Wheel Kit - Black Calipers
- AFXWK51DZ67-69At-The-Wheel Kit - Red Calipers
- AFXSD51DS67-69Manual Kit - Black Calipers
- AFXSD51DZ67-69Manual Kit - Red Calipers
- AFXDC51DS67-69Power Kit - Black Calipers
- AFXDC51DZ67-69Power Kit - Black Calipers

2" Drop - Staggered Shocks

- AFXWK55DS67-69At-The-Wheel Kit - Black Calipers
- AFXWK55DZ67-69At-The-Wheel Kit - Red Calipers
- AFXSD55DS67-69Manual Kit - Black Calipers
- AFXSD55DZ67-69Manual Kit - Red Calipers
- AFXDC55DS67-69Power Kit - Black Calipers
- AFXDC55DZ67-69Power Kit - Black Calipers

X-TRIM DISC BRAKE CONVERSION UPGRADES



X-TRIM UPGRADE 4-WHEEL KITS

Non-Staggered Shocks

- AFXSD51CSX.....67-69... Manual Kit - Black Calipers - Stock Height
- AFXSD51CZX.....67-69... Manual Kit - Red Calipers - Stock Height
- AFXDC51CSX ...67-69... Power Kit - Black Calipers - Stock Height
- AFXDC51CZX ...67-69... Power Kit - Red Calipers - Stock Height
- AFXSD51DSX.....67-69... Manual Kit - Black Calipers - 2" Drop
- AFXSD51DZX.....67-69... Manual Kit - Red Calipers - 2" Drop
- AFXDC51DSX.....67-69... Power Kit - Black Calipers - 2" Drop
- AFXDC51DZX ...67-69... Power Kit - Red Calipers - 2" Drop

Staggered Shocks

- AFXSD55CSX.....67-69...Manual Kit - Black Calipers - Stock Height
- AFXSD55CZX.....67-69...Manual Kit - Red Calipers - Stock Height
- AFXDC55CSX ...67-69...Power Kit - Black Calipers - Stock Height
- AFXDC55CZX ...67-69...Power Kit - Red Calipers - Stock Height
- AFXSD55DSX67-69...Manual Kit - Black Calipers - 2" Drop
- AFXSD55DZX67-69...Manual Kit - Red Calipers - 2" Drop
- AFXDC55DSX.....67-69...Power Kit - Black Calipers - 2" Drop
- AFXDC55DZX ...67-69...Power Kit - Red Calipers - 2" Drop

Start turning heads with a show finished upper assembly. Manual kits get a chrome plated master cylinder and-combination valve with bracket. Power kits also include an 8" dual chrome booster.



X-TRIM UPGRADE FRONT KITS

Stock Height uses existing spindles

- AFXSD31CSX..... 67-69.... Manual Kit - Black Calipers - Stock Height
- AFXSD31CZX..... 67-69.... Manual Kit - Red Calipers - Stock Height
- AFXDC31CSX 67-69.... Power Kit - Black Calipers - Stock Height
- AFXDC31CZX 67-69.... Power Kit - Red Calipers - Stock Height

2" Drop includes new spindles

- AFXSD31DSX..... 67-69.... Manual Kit - Black Calipers - 2" Drop
- AFXSD31DZX..... 67-69.... Manual Kit - Red Calipers - 2" Drop
- AFXDC31DSX..... 67-69.... Power Kit - Black Calipers - 2" Drop
- AFXDC31DZX 67-69.... Power Kit - Red Calipers - 2" Drop



REAR DISC BRAKE CONVERSION KITS

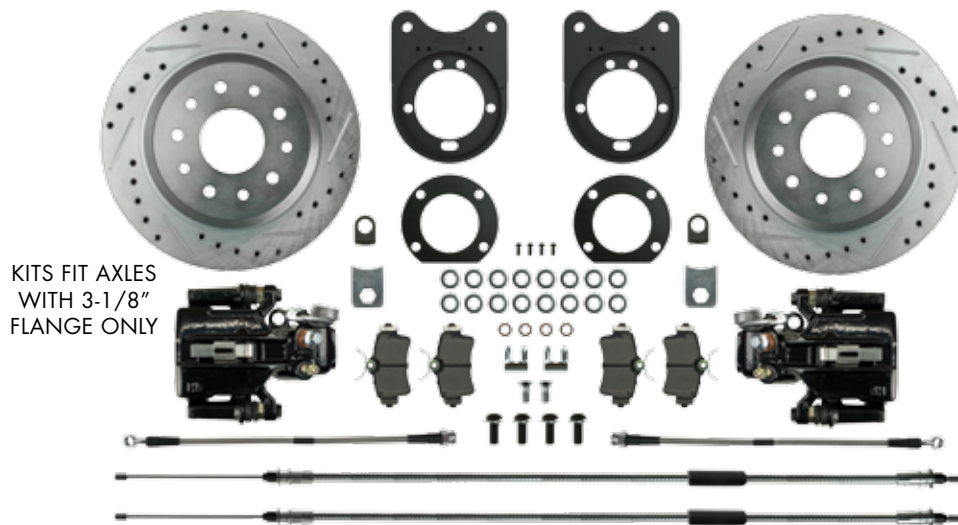

KITS FIT AXLES WITH 3-1/8" FLANGE ONLY

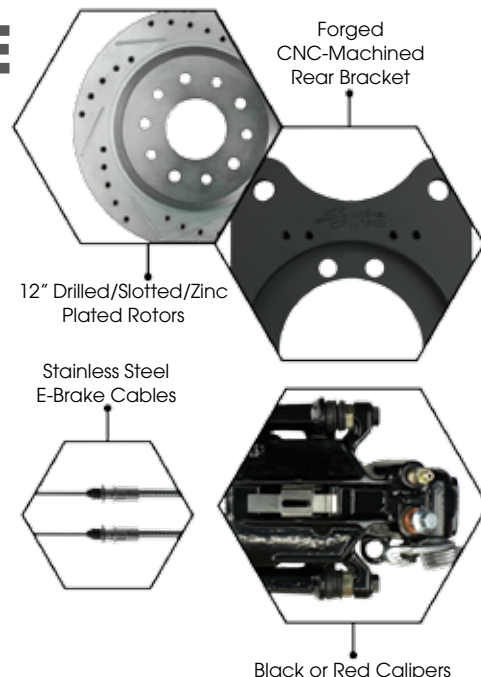

REAR DISC CONVERSION KITS

- AFXRD31S 67-68 10/12-Bolt Non-Staggered Shocks - Black
- AFXRD31Z 67-68 10/12-Bolt Non-Staggered Shocks - Red
- AFXRD35S 68-69 10/12-Bolt Staggered Shocks - Black
- AFXRD35Z 68-69 10/12-Bolt Staggered Shocks - Red
- AFXRD36S 70-74 10/12-Bolt Staggered Shocks - Black
- AFXRD36Z 70-74 10/12-Bolt Staggered Shocks - Red
- AFXRD37S 75-81 10/12-Bolt Staggered Shocks - Black
- AFXRD37Z 75-81 10/12-Bolt Staggered Shocks - Red



Disc Brake Conversions require special brake lines that fit your new

disc conversion setup. Right Stuff offers "No Brainer" Brake Line Kits that include all components needed from your master cylinder back to your rear wheel cylinder or calipers. They include front brake line kit, front to rear line, rear axle lines & flex hose, & clip set.

CAMARO BRAKE LINES



No Brainer BRAKE LINE KITS

DESIGNED FOR DISC CONVERSIONS

When you add disc brakes to your car you are using a new valve that has different size ports pointing in different directions. Even if your lines are brand new or great originals, you are going to have issues trying to use them. Our No Brainer Brake Line Kit fixes all these issues from your master cylinder all the way back to your rear wheel cylinders or rear calipers. We give you all the lines to complete the installation. We also include the rear flex hose and a full clip set to install your lines. Extremely discounted prices and great instructions make this kit a No Brainer.

SIMPLIFY YOUR DISC BRAKE CONVERSION INSTALLATION WITH ALL OF THE BRAKE LINES YOU WILL NEED.

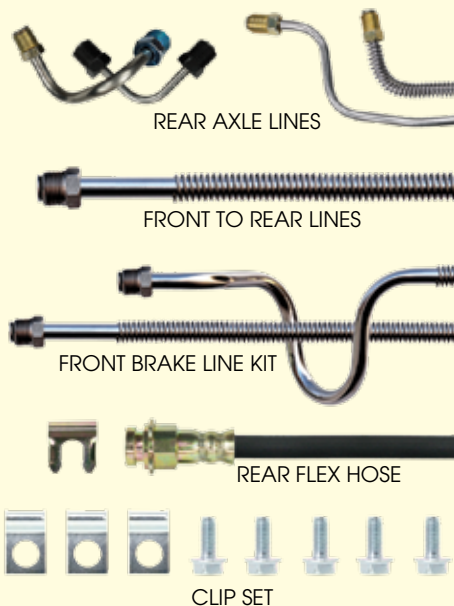

MANUAL - NO VACUUM BOOSTER

FRONT DISC/REAR DRUM LINES

- FOM67H2 1967OE Steel Brake Line Kit
- FSM67H2 1967Stainless Steel Brake Line Kit
- FOM68H2 1968OE Steel Brake Line Kit
- FSM68H2 1968Stainless Steel Brake Line Kit
- FOM69H2 1969OE Steel Brake Line Kit
- FSM69H2 1969Stainless Steel Brake Line Kit

4-WHEEL DISC LINES

- FOM67H4 1967OE Steel Brake Line Kit
- FSM67H4 1967Stainless Steel Brake Line Kit
- FOM68H4 1968OE Steel Brake Line Kit
- FSM68H4 1968Stainless Steel Brake Line Kit
- FOM69H4 1969OE Steel Brake Line Kit
- FSM69H4 1969Stainless Steel Brake Line Kit



POWER - WITH VACUUM BOOSTER

FRONT DISC/REAR DRUM LINES

- FOP67H2 1967OE Steel Brake Line Kit
- FSP67H2 1967Stainless Steel Brake Line Kit
- FOP68H2 1968OE Steel Brake Line Kit
- FSP68H2 1968Stainless Steel Brake Line Kit
- FOP69H2 1969OE Steel Brake Line Kit
- FSP69H2 1969Stainless Steel Brake Line Kit

4-WHEEL DISC LINES

- FOP67H4 1967OE Steel Brake Line Kit
- FSP67H4 1967Stainless Steel Brake Line Kit
- FOP68H4 1968OE Steel Brake Line Kit
- FSP68H4 1968Stainless Steel Brake Line Kit
- FOP69H4 1969OE Steel Brake Line Kit
- FSP69H4 1969Stainless Steel Brake Line Kit

PROPORTIONING VALVES

DOES YOUR VALVE LOOK LIKE THIS?

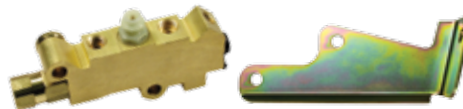

When upgrading to disc brakes or keeping them stock, make sure your proportioning valve is designed for the brake system that is specific to your vehicle.



- PVK71Disc/Drum Proportioning Valve - Brass Finish
- PVK72Disc/Disc Proportioning Valve - Brass Finish
- PVK71C.....Disc/Drum Proportioning Valve - Chrome Finish
- PVK72C.....Disc/Disc Proportioning Valve - Chrome Finish

FRONT BRAKE LINE KITS



Front brake line kits consist of all brake lines under the hood. This includes the master cylinder to the distribution, combination or metering valve. The left and right front lines that run to the front flex hoses are also included. Call for individual component pricing. These line kits are for vehicles with factory brake systems.

ADD "S" TO PART NUMBER FOR STAINLESS STEEL

VKT5301	53	Standard Brakes.....	3 Pcs
VKT5401	54	3/16" Front.....	4 Pcs
VKT5501	55	1/4" Front X-Over.....	4 Pcs
VKT5601 ..	56-62 ...	All Cars.....	4 Pcs
VKT6301 ..	63-64 ...	Standard Brakes.....	3 Pcs
VKT6302 ..	63-64 ...	Power Brakes.....	3 Pcs
VKT6502	65	3/16" Master Cylinder Power ..	3 Pcs
VKT6501 ..	65-66 ...	Standard Brakes.....	3 Pcs

ADD "S" TO PART NUMBER FOR STAINLESS STEEL

VKT6503 ..	65-66 ...	1/4" Master Cylinder Power ...	3 Pcs
VKT6701	67	Standard Brakes.....	5 Pcs
VKT6702	67	Power Brakes.....	5 Pcs
VKT6801	68	Standard Brakes.....	5 Pcs
VKT6802	68	Power Brakes.....	5 Pcs
VKT6901	69	Standard Brakes.....	4 Pcs
VKT6902	69	Power Brakes.....	4 Pcs
VKT7001 ..	70-73 ...	Standard Brakes.....	4 Pcs
VKT7002 ..	70-73 ...	Power Brakes.....	4 Pcs
VKT7401 ..	74-82 ...	Standard Brakes.....	4 Pcs
VKT7402 ..	74-82 ...	Power Brakes.....	4 Pcs
VBS8609 ..	86-89 ...	Complete Power Brake Set.....	7 Pcs
VBS8901	89	C4, Complete Set.....	8 Pcs
VBS9201 ..	92-96 ...	Kelsey Hayes ABS.....	8 Pcs
VBS9601	96	Power Disc, Bosch ABS.....	7 Pcs

REAR AXLE BRAKE LINES

Rear axle brake lines include a pair of lines that run across the rear axle housing. These lines connect the wheel cylinders or calipers to the flex hose in the middle of the rear end. These lines work with original housings that use factory brakes. Modifications such as rear disc brakes or narrowed rear ends will likely require special lines. Call for more information.

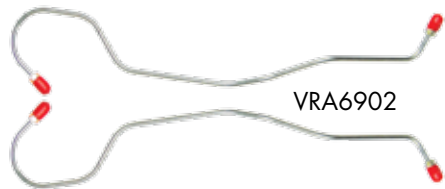

ADD "S" TO PART NUMBER FOR STAINLESS STEEL

VRA5301	53-55....	Left & Right.....	2 Pcs
VRA5601	56-62....	Left & Right.....	2 Pcs
VRA6302	63-64....	Left & Right.....	2 Pcs
VRA6301	63-82....	Rear Axle X-Over Line.....	1 Pc
VRA6502	65-68....	Left & Right with Armor.....	2 Pcs
VRA6902	69-82....	Left & Right without Armor.....	2 Pcs

REAR AXLE VENT TUBES

VPT5701	57-62...	Posi-Traction Vent Tube - OE Steel
VPT5701S.....	57-62...	Posi-Traction Vent Tube - Stainless

FRONT FLEX HOSES

Front flex hoses provide a flexible connection from the body or frame to the front calipers or wheel cylinders as they move during suspension travel. Choose between O.E. rubber or braided stainless steel. All of our hoses are D.O.T. approved. Hoses are priced individually.



ADD "S" TO PART NUMBER FOR STAINLESS STEEL

FHV1	53-62	Front & Rear, All
FHV2	63-82	Front

REAR FLEX HOSES

Rear flex hoses carry brake fluid between the body of the car and the rear. Hoses are available in O.E. rubber and braided stainless steel. 'T' blocks are attached whenever factory correct. All of our hoses are D.O.T. approved. Prices are per hose.

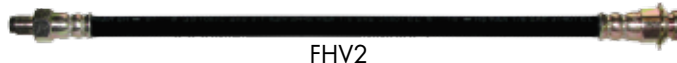

ADD "S" TO PART NUMBER FOR STAINLESS STEEL

FHV1	53-62	Front & Rear, All
FHV3	63-82	Rear

CORVETTE BRAKE LINES & CALIPERS

FRONT TO REAR BRAKE LINES

VIN7012



Front to rear brake lines go from the distribution, combination or metering valve along the length of the vehicle to the rear flex hose. Manufactured in 1 or 2 pieces based on factory specs.

ADD "S" TO PART NUMBER FOR STAINLESS STEEL

- VIN530253 All Cars..... 2 Pcs
- VIN5301 .. 54-62 ... All Cars
- VIN6303 .. 63-64 ... Power Brakes
- VIN6303 .. 63-65 ... Standard Brakes
- VIN650565 Power Brakes, 3/16" Line
- VIN6506 .. 65-66 ... Power Brakes, 1/4" Line

ADD "S" TO PART NUMBER FOR STAINLESS STEEL

- VIN660866 Standard Brakes
- VIN670967 Power Brakes
- VIN671067 Standard Brakes
- VIN681068 Standard Brakes
- VIN680968 Power Brakes
- VIN691169 Power or Standard Brakes
- VIN7012 .. 70-73 ... Power or Standard Brakes
- VIN7413 .. 74-82 ... Power or Standard Brakes
- VIN850185 Front/Rear Brake Line

BRAKE LINE CLIPS

Brake line clip sets contain all the clips needed to fasten the brake tubes to the frame or body of the car. Individual clips and fasteners are also available.



- VCS580158-62... Complete Clip Set
- VCS630163-65... Complete Clip Set
- VCS6601 66 Complete Clip Set
- VCS6701 67 Complete Clip Set
- VCS6801 68 Complete Clip Set, without Fuel Return
- VCS6802 68 Complete Clip Set, with Fuel Return
- VCS690169-72... Complete Clip Set, without Fuel Return
- VCS690269-72... Complete Clip Set, with Fuel Return
- VCS7301 73 Complete Clip Set
- VCS740174-82... Complete Clip Set

CALIPERS & PADS

Rebuild calipers do not include pads or hardware. Core charges apply as noted.



VC02

- VC01 ... 65-82Left Front, with Exchange
- VC02 ... 65-82Right Front, with Exchange
- VC03 ... 65-82Left Rear, with Exchange
- VC04 ... 65-82Right Rear, with Exchange
- DPV1 65-82D-8 Pads (2 sets)

WHEEL CYLINDERS

Wheel cylinders are priced individually. Hardware is not included.



WC20

WC47

- WC47..... 53-55..... Left Or Right Rear
- WC20..... 53-59..... Left Front
- WC21..... 53-59..... Right Front
- WC11..... 56-63..... Left Rear
- WC12..... 56-63..... Right Rear
- WC30..... 63-65..... Left Front
- WC31..... 63-65..... Right Front

DRUM BRAKE COMPONENTS

Available components include backing plates, adjusters and spring sets. Brake drum hardware kits contain the springs and retainers needed to rebuild an original drum brake assembly. Adjusters are sold in pairs.

- DHK630163-65... Front or Rear Hardware (2 Sets)
- DHK630262-65... Front or Rear, Adjusters (2 Pcs)

BRAKE HOSE HARDWARE

Hose hardware is used to secure flex hoses to various parts of the vehicle.

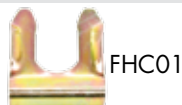

FHC01

Cost

- FHC01Correct Gold Cadmium Plated C Clips

VALVES & BLOCKS

We offer a full line of metering blocks, proportioning valves, distribution blocks & combination valves for factory drum & disc brake applications.



PV69

- PV67 67-68 Cast Iron Block and Bracket
- PV69 69 Brass Block and Bracket
- PV70C..... 70-73 Brass Block and Bracket

CORVETTE FUEL LINES & MASTER CYLINDERS

MAIN FUEL LINES

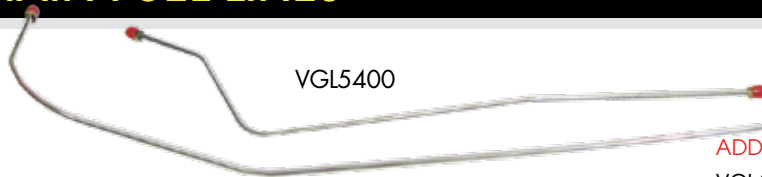

Main lines carry fuel from the tank in the rear of the car to the fuel pump or rail in the front. They are available in 3/8" and 5/16" tubing based on factory specifications. Multiple piece sets are noted. Call for 1/2" lines.

ADD "S" TO PART NUMBER FOR STAINLESS STEEL

VGL5301.....53.....5/16" Main Line	2 Pcs
VGL5400.....54.....5/16" Main Line	2 Pcs
VGL5500.....55.....5/16" Main Line	2 Pcs
VGL5601.....56.....5/16" Main Line	3 Pcs
VGL5602.....56-57.....3/8" Main Line	3 Pcs
VGL5803.....58-60.....3/8" Main Line	2 Pcs

ADD "S" TO PART NUMBER FOR STAINLESS STEEL

VGL6101.....61-62.....3/8" Main Line	2 Pcs
VGL6302.....63-67.....3/8" Main Line - Small Block	
VGL6503.....65-67.....3/8" Main Line - Big Block	
VGL6804.....68.....3/8" Main Line	
VGL6807.....68.....1/4" Vent Line - Right Tank	
VGL6905.....69.....3/8" Main Line	
VGL7006.....70-74.....3/8" Main Line	
VGL7007.....75-77.....3/8" Main Line	
VGL7808.....78-82.....3/8" Main Line	
VGL8501.....85.....3/8" Main Fuel	
VGL8601.....86.....3/8" Main Line	
VGL9201.....92-96.....3/8" Main Line, 5.7 L	

RETURN FUEL LINES

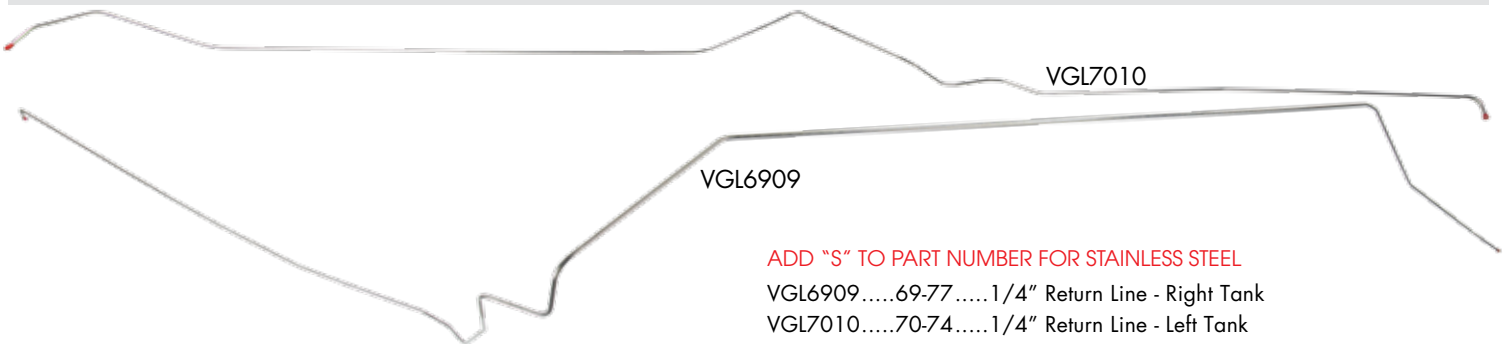

Return lines carry excess fuel from fuel pump or fuel filter back to the tank. Not all vehicles were equipped with a return line. They are typically made of 1/4" diameter tubing. Multiple piece sets are noted.

ADD "S" TO PART NUMBER FOR STAINLESS STEEL

VGL6909.....69-77.....1/4" Return Line - Right Tank
VGL7010.....70-74.....1/4" Return Line - Left Tank
VGL7005.....75-77.....1/4" Return Line - Right Tank
VGL7011.....75-77.....1/4" Return Line - Left Tank
VGL7811.....78-82.....1/4" Return Line - Right Tank
VGL7812.....78-82.....1/4" Return Line - Left Tank
VGL8500.....85.....5/16" Vapor Line
VGL8502.....85.....1/4" Return Line, 3-Piece
VGL8602.....86.....1/4" Return Line
VGL9202.....92-96.....3/8" Return Line, 5.7 L

MASTER CYLINDERS

Master cylinders are completely new units with no core charge. A deep cylinder pocket with a removable plug provides compatibility with manual brakes as well as power-assisted applications.



DBMC51C



DBMC09



DBMC09

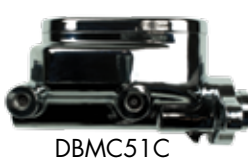

DBMC51C

DBMC09.....65-76.....Power Brakes, 1-1/8" Bore
DBMC09.....67-68.....Standard Brakes, 1-1/8" Bore
DBMC09C.....65-76.....Power Brakes, 1-1/8" Bore, Chrome
DBMC05C.....65-76.....Power Brakes, 1" Bore, Chrome
DBMC51C.....65-76.....Power Brakes, 1-1/8" Bore, Chrome
DBMC56C.....65-76.....Power Brakes, 1" Bore, Chrome

DELCO BOOSTERS

These boosters are reproductions based on original factory units. Mounting brackets included.



RPB9018



RPB9522

RPB9018.....63-67... Delco, High Quality Reproduction
RPB9018C.....63-67... Delco, Chrome, Bolt On Brackets
RPB9512.....68-82... Delco Style, OE Was Bendix, Y7 Rod Black

CORVETTE FUEL LINES

FUEL PUMP TO CARB LINES

Fuel pump to carburetor lines connect the fuel pump to the carburetor. Brass blocks and fittings are included as noted. These lines are intended to work only with factory pump, motor, intake and carburetor combinations.



ADD "S" TO PART NUMBER FOR STAINLESS STEEL

- VPC5301..... 53..... 5/16" Line
- VPC5401..... 54..... 235, 6 Cylinder
- VPC5501... 55-56 ... 195, 210 HP Line with 3 Fittings
- VPC5604... 56-58 ... Dual Quad., 3 Lines with 5 Fittings
- VPC5702... 57-58 ... 220, 230 HP Line with 3 Fittings
- VPC5706... 57-58 ... Fuel Injection, 2 Lines with 4 Fittings
- VPC5905... 59-61 ... Dual, Quad., 3 Lines with 5 Fittings
- VPC5907... 59-61 ... Fuel Injected Line with 1 Fitting
- VPC5903... 59-62 ... 230, 250 HP Line with 1 Fitting
- VPC6208..... 62..... Fuel Injected Line with 2 Fittings
- VPC6209..... 62..... 300, 340 HP Line with 3 Fittings
- VPC6312..... 63..... 340 HP, 2 Lines with 4 Fittings, Chrome
- VPC6310... 63-65 ... 250 HP Line with 1 Fitting
- VPC6311... 63-65 ... 300 HP, 2 Lines with 4 Fittings
- VPC6314... 63-65 ... Fuel Inj., 2 Lines w/ 4 Fittings, Chrome
- VPC6315... 63-65 ... Fuel Pump Inlet Line & Fitting
- VPC6413... 64-65 ... 350, 365 HP Line, Rubber Hose, 2 Pinch Clamps with 3 Fittings, Chrome
- VPC6516..... 65..... 396, 425 HP, 3 Lines with 2 Fittings, No Block

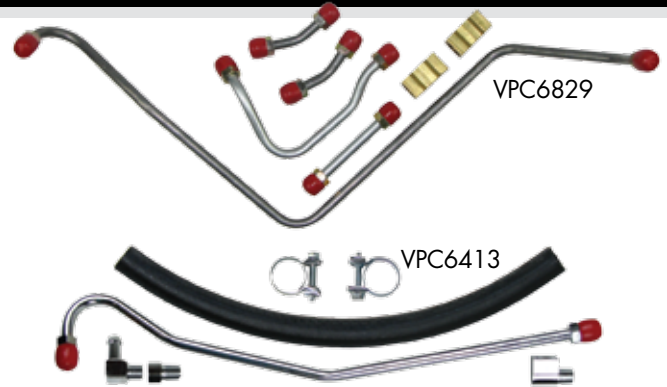

- VPC6617..... 66..... 327/300 HP, 1 Line & Fitting, Chrome
- VPC6618..... 66..... 327/350 HP, 1 Line & Fitting, Chrome
- VPC6619..... 66..... 360 HP, 1 Line with 1 Fitting
- VPC6620..... 66..... 425 HP, 3 Lines, with 1 Fitting, Y-Block
- VPC6721..... 67..... 300 HP, 5/16" Line
- VPC6722..... 67..... 350 HP, 5/16" Line
- VPC6723..... 67..... 390 HP, 3/8" Line
- VPC6724..... 67..... 400/435 HP, 3x2, 5 Lines, 2 Tees
- VPC6725... 67-69 ... L-88, 3 Lines, Special "Y" Block
- VPC6827..... 68..... 390 HP, 3 Lines with Filter
- VPC6826... 68-69 ... 300, 350 HP, 3 Lines with Filter
- VPC6828... 68-69 ... 427/400 HP, 3x2, 5 lines, 2 Blocks
- VPC6829... 68-69 ... 400, 435 HP, 3x2's, 5 Lines, 2 Tees
- VPC6928..... 69..... 390 HP, 3 Lines w Quad, with Filter
- VPC7031... 70-72 ... LT-1, 3 Lines, Special "Y" Block
- VPC7033... 70-74 ... 454, Quadrajet
- VPC7030... 70-76 ... 200, 300, 350 HP, L-48, L-82
- VPC7132... 71-72 ... LS-6, 454, 3 Lines, Tee Block
- VPC7734... 77-79 ... L-82, L-48, All Cars
- VPC82TB 82..... Throttle Body Lines, 3-Piece

VAPOR RETURN LINES

Emission control systems use these 5/16" lines to handle fuel vapors. Some vehicles use a single front to rear line. Others utilize a charcoal canister and require 3 or 4 additional small lines. Multiple piece sets are noted.

ADD "S" TO PART NUMBER FOR STAINLESS STEEL

- VGL7812.....78-82.... 1/4" Vapor Line - Left Tank
- VGL8500..... 85 5/16" Vapor Line
- VGL8603..... 86 1/4" Vapor Line, 2-Piece

THERMAL CHOKE LINES

Thermal choke lines carry heat from the exhaust system to the choke coil on the carburetor. Some applications route thru the intake manifold on their way to the carburetor.

- VCH6301.....63 ... 300 ci/327 HP Choke Tube Set, 2-Pc - OE Steel
- VCH6301S...63 ... 300 ci/327 HP Choke Tube Set, 2-Pc - Stainless

FUEL HOSE KITS

These small rubber hoses and clips are used to connect fuel lines to the fuel pump and sending unit.



- FHK3800.....ALL..... 3/8" x 6", 3/8" x 13", + 4 Green Clamps
- FHK1438.....ALL..... 3/8" x 6", 3/8" x 13", 1/4" x 18" + 4 Green Clamps and 4 Red Clamps



TRANSMISSION COOLER LINES

Transmission cooler lines are sold as pairs. Be sure to verify the type of transmission in your project before ordering. These lines are intended to work only with factory motor, transmission, and radiator combinations.

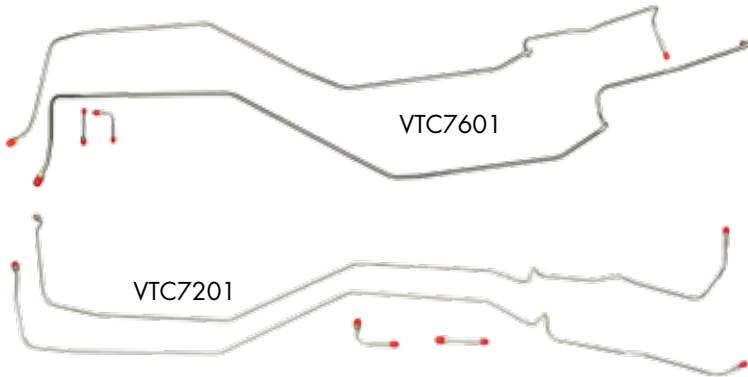

ADD "S" TO PART NUMBER FOR STAINLESS STEEL

- VTC6301 63-65 Small Block, Powerglide
- VTC6901 68-69 All Cars
- VTC6901 70-74 Small Block
- VTC7201 72-75 Turbo 400
- VTC7601 76-79 Turbo 350
- VTC8201 82 700-RA

TRANSMISSION VACUUM LINES

Transmission vacuum lines connect automatic transmissions to intake vacuum.

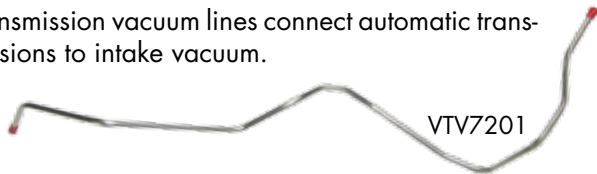

ADD "S" TO PART NUMBER FOR STAINLESS STEEL

- VTV5301 53-54 6 Cylinder, with Fittings
- VTV5401 54-55 6 Cylinder, with Rubber Hose
- VTV6801 68 T-400
- VTV7201 72-75 Turbo 400

VACUUM LINES

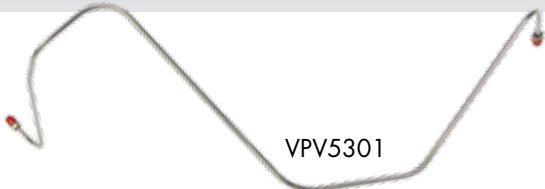

ADD "S" TO PART NUMBER FOR STAINLESS STEEL

- VMV5301.. 53-55 ... Wiper to Fuel Pump All Cars
- VFI6101 61 Complete Set 3 Pcs
- VFI6201 62 Balance Tube
- VFI6202 62 Cranking Signal
- VFI6203 62 Main Diaphragm
- VFI6204 62 Enrichment Diaphragm
- VPV5301 ... 53-55 ... Intake to Pump All Cars, 6 Cylinder
- VPV6601 66 Intake to Pump V-56 Valve
- VPV6701 ... 67-68 ... Intake to Pump V-56 Valve

SUSPENSION PARTS

UPPER & LOWER BALL JOINTS



- XK6035 63-82 Lower Ball Joint
- XK6034 63-82 Upper Ball Joint

COMING IN 2017

UPPER & LOWER CONTROL ARM BUSHING KITS



- XK304 63-82 Lower Control Arm Bushings, 4-Piece
- XK5196 63-82 Upper Control Arm Bushings, 2-Piece

DISTRIBUTOR VACUUM LINES

Distributor vacuum lines supply intake vacuum to the distributor for timing control.

ADD "S" TO PART NUMBER FOR STAINLESS STEEL

- VDV5301 ... 53-54 ... 235, 6 Cylinder - OE Steel
- VDV5301 ... 53-54 ... 235, 6 Cylinder - Stainless
- VDV6516 63 Distributor Vacuum Line - OE Steel
- VDV6516 63 Distributor Vacuum Line - Stainless
- VDV6301 63 Distributor Vacuum Line - OE Steel
- VDV6301 63 Distributor Vacuum Line - Stainless



CHEVELLE / EL CAMINO BRAKE LINES

FRONT BRAKE LINE KITS

Front brake line kits consist of all brake lines under the hood. This includes the master cylinder to the distribution, combination or metering valve. The left and right front lines that run to the front flex hoses are also included. Call for individual component pricing. These line kits are for vehicles with factory brake systems.

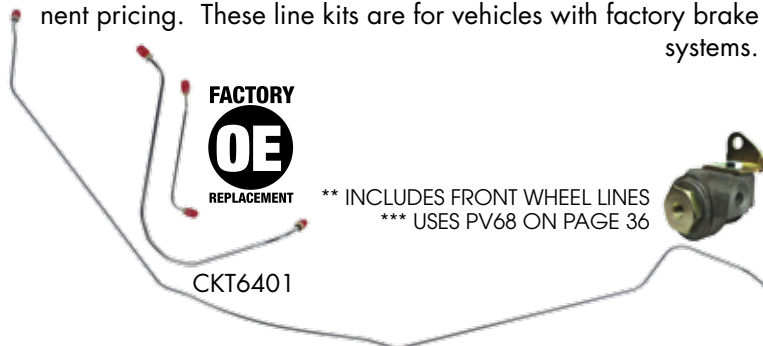

** INCLUDES FRONT WHEEL LINES
*** USES PV68 ON PAGE 36

ADD "S" TO PART NUMBER FOR STAINLESS STEEL

CKT6401.. 64-65 ... Standard Drum, Malibu.....	3 Pcs
CKT6402.. 64-66 ... Power Drum, Malibu.....	3 Pcs
CKT6501.....65 Standard Drum, SS & Z-16	3 Pcs
CKT6604.. 65-66 ... Power Drum, SS & Z-16	3 Pcs
CKT6601.....66 Standard Drum, Malibu.....	3 Pcs
CKT6602.....66 Standard Drum, SS & Z-16	3 Pcs
CKT6701.....67 Standard Drum, Malibu.....	4 Pcs
CKT6702.....67 Power Drum, Malibu	4 Pcs
CKT6703.....67 Standard Drum, SS	4 Pcs
CKT6704.....67 Power Drum, SS	4 Pcs
CKT6705.....67 Standard Disc, SS ***	5 Pcs
CKT6706.....67 Power Disc, SS ***	5 Pcs
CKT6801.....68 Standard Drum, Malibu**	6 Pcs
CKT6803.....68 Power Disc ***	5 Pcs
CKT6804.....68 Standard Drum, SS **	6 Pcs
CKT6805.....68 Power Drum, SS **	6 Pcs
CKT6802.. 68-72 ... Power Drum, Malibu **	6 Pcs
CKT6903.....69 Power Disc ***	5 Pcs
CKT6901.. 69-72 ... Standard Drum **	6 Pcs
CKT7003.....70 Power Disc	5 Pcs
CKT7103.. 71-72 ... Power Disc	4 Pcs
CKT7303.. 73-74 ... Power Disc	4 Pcs
CKT7503.. 75-76 ... Power Disc	4 Pcs
CKT7703.....77 Power Disc, Malibu	4 Pcs
CKT7901.. 78-79 ... Power Disc, Malibu	4 Pcs
CKT8001.. 78-79 ... Power Disc	4 Pcs

FRONT TO REAR BRAKE LINES

Front to rear brake lines go from the distribution, combination or metering valve along the length of the vehicle to the rear flex hose. Manufactured in 1 or 2 pieces based on factory specifications.



ADD "S" TO PART NUMBER FOR STAINLESS STEEL

CIN6401	64	Hardtop	
CIN6404	64	4 Door Wagon	
CIN6402	64-65	Convertible	
CIN6402	65	Z-16 & El Camino	
CIN6503	65	Hardtop	
CIN6605	66	Hardtop	
CIN6606	66	Convertible & El Camino	
CIN6709	67	Hardtop	
CIN6710	67	Convertible & El Camino	
CIN6801	68	Hardtop	
CIN6802	68	Convertible	
CIN6818	68	4 Door	
CIN68EC	68-69	El Camino	
CIN6815	69	Hardtop	
CIN6816	69	Convertible	
CIN7021	70	Hardtop DISC ONLY	2 Pcs
CIN7022	70	Convertible DISC ONLY	2 Pcs
CIN70EC	70	El Camino	2 Pcs
CIN7131	70	Hardtop Drum	
CIN7132	70	Convertible Drum	
CIN70SW	70-72	Wagon with Power Disc	
CIN7104	71-72	4 Door	
CIN7131	71-72	Hardtop Except 4 Door	
CIN7132	71-72	Convertible	
CIN71EC	71-72	El Camino	
CIN7105	71	Chevelle Wagon	
CIN7601	73-77	All Cars	
CIN74EC	74	El Camino	
CIN75EC	75	El Camino	
CIN78EC	78-87	El Camino	
CIN8001	78-83	Malibu with Power Disc	

REAR AXLE BRAKE LINES

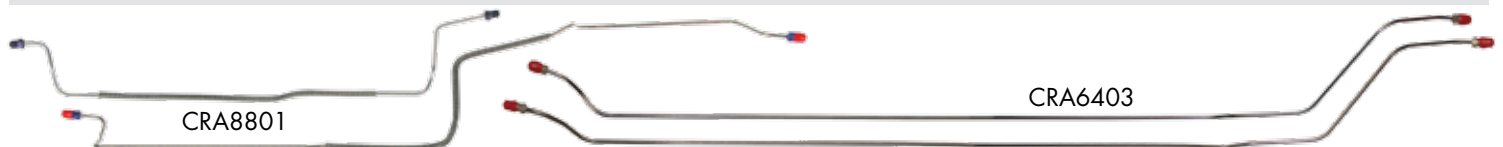

Rear axle brake lines include a pair of lines that run across the rear axle housing & connect the wheel cylinders or calipers to the flex hose in the middle of the rear end. Lines work with original housings that use factory brakes. Modifications such as rear disc brakes or narrowed rear ends will likely require special lines. Call for more information.



ADD "S" TO PART NUMBER FOR STAINLESS STEEL

CRA6403	64-67	All Cars
CRA6803	68-72	All Cars
CRA7303	73-77	All Cars
CRA8001	78-88	Malibu
CRA8002	78-81	El Camino
CRA8201	82-87	El Camino

HOSE BRACKETS

These brackets and hardware are used to secure flex hoses to various parts of the vehicle. Front brackets are sold in pairs.



- BB6901 69 Banjo Bolt
- CW6901 69 Copper Washer
- FHC01 All Yellow Zinc Plated C Clip
- FHC01S All Silver Zinc Plated C Clip
- RSBB01 64-68 Rear Hose Brass 'T' Block
- RSBK10 64-68 Rear Hose Bracket, Used with Screw On Block
- RSBK66 68 4 Piston Caliper Inlet Line Brackets
- RSBK70 68-72 Front Hose Brackets, Disc Only (pr)
- RSBK12 68-72 12 Bolt Rear Hose Bracket

BRAKE LINE CLIPS

Brake line clip sets contain all the clips needed to fasten the brake tubes to the frame or body of the car. Individual clips and fasteners are available on pages 284-285.



- CCS013 64-66 ... Complete Set 9 Pcs.
- CCS014 67 Complete Set 10 Pcs.
- CCS015 68 Complete Set 8 Pcs.
- CCS016 69 Complete Set 10 Pcs.
- CCS020 70 Complete Set 10 Pcs.
- CCS021 71-72 ... Complete Set 10 Pcs.

WHEEL CYLINDERS

Wheel cylinders are priced individually. Hardware is not included.



- WC09 65-67 Left Front
- WC10 65-67 Right Front
- WC07 65-69 Left or Right Rear
- WC05 68-72 Left Front
- WC06 68-72 Right Front
- WC08 70-75 Left or Right Rear
- WC58 73-77 Malibu Rear, 15/16" Bore
- WC59 78-88 Left or Right Rear

FRONT FLEX HOSES

Front flex hoses provide a flexible connection from the body or frame to the front calipers or wheel cylinders as they move during suspension travel. Choose between O.E. rubber or braided stainless steel. All of our hoses are D.O.T. approved. Hoses are priced individually.



ADD "S" TO PART NUMBER FOR STAINLESS STEEL

- FH14 64-67 Drum
- FH26 67 Disc
- FH21 68 Disc
- FH21 68-72 Drum
- FH20 69-72 Disc
- FH162 73-75 All Cars
- FH163 76 All Cars
- FH08 77 All Cars
- FH164 78 All Cars
- FH79 79-83 All Cars

REAR FLEX HOSES

Rear flex hoses carry brake fluid between the body of the car and the rear. Hoses are available in O.E. rubber and braided stainless steel. 'T' blocks are attached whenever factory correct. All of our hoses are D.O.T. approved. Prices are per hose.



ADD "S" TO PART NUMBER FOR STAINLESS STEEL

- FH17 64-65 All Cars
- FH04 66-67 All Cars
- FH19 68 All Cars
- FH06 69-72 All Cars
- FH165 73 All Cars
- FH13 74-77 All Cars
- FH166 78-83 All Cars

DISC CALIPER LINES

Front disc caliper lines connect the front flex hoses to the calipers. They were typically used on 4 piston calipers in the late 1960's. Several fitting sizes were available from the factory. Please verify fitting sizes before ordering as rebuilt calipers may not match the originals.



ADD "S" TO PART NUMBER FOR STAINLESS STEEL

- CFC6701 ...67-68... 1/2" Right Port & 7/16" Left Port (pr)
- CFC6702 ...67-68... 3/8" Left Port & Right Ports (pr)

CHEVELLE / EL CAMINO E-BRAKE & DRUM BRAKES

E-BRAKE CABLES

Parking brake cable sets contain all the individual cables and hardware needed to restore the system. Front, rear, and intermediate cables are also sold individually. Sold in O.E. mild steel and stainless steel. These listed cables are for drum brake rear ends. Call if you have a rear disc conversion. While supplies last.



• E-Brake Cable Kits

- RSBCC01 ... 64-67 ... Chevelle, Powerglide or Manual
- RSBCC06 ... 64-67 ... El Camino, Powerglide or Manual
- RSBCC02 67 Chevelle, Turbo 400
- RSBCC07 67 El Camino, Turbo 400
- RSBCC03 ... 68-72 ... Chevelle, Excluding Turbo 400
- RSBCC04 ... 68-72 ... Chevelle, Turbo 400
- RSBCC08 ... 68-72 ... El Camino, Excluding Turbo 400
- RSBCC09 ... 68-72 ... El Camino, Turbo 400
- RSBCC05 ... 73-77 ... Chevelle, All Cars
- RSBCM06 ... 78-88 ... Chevelle / Monte Carlo, Manual
- RSBCM06 ... 81-88 ... Chevelle / Monte Carlo, Automatic

• Front Brake Cables

- EBC7001 64-67 Chevelle, Excl. T-400
- EBC7023 64-67 Chevelle T-400
- EBC7026 64-67 El Camino, Excl. T-400
- EBC7005 68-72 Chevelle, Excl. T-400
- EBC7006 68-72 Chevelle, T-400
- EBC7027 68-72 El Camino, Excl. T-400
- EBC7031 68-72 El Camino, T-400
- EBC7040 73-77 Chevelle, All Cars

• Intermediate Brake Cables

- EBC8001 64-67 All Cars, Excl. T-400
- EBC8005 67-72 Chevelle, Excl. T-400
- EBC8005 67 All Cars, T-400
- EBC8005 67-72 El Camino, Excl. T-400
- EBC8006 68-72 Chevelle, T-400
- EBC8027 68-72 El Camino, T-400
- EBC8030 73-77 Chevelle, All Cars

• E-Brake Hardware - Chevelle

- EBH3001 64-77 Olive Green Center Pull, Chevelle
- EBH3002 64-72 Center to Rear Silver Connector
- RSCLP23 64-77 Parking Brake Clip - Black
- EBH2001 64-77 6' Silver Front Hook, Excl. T-400, Chevelle
- EBH2002 64-67 Side Hook, Chevelle
- EBH1001 64-72 Jam Nut
- EBH2006 67 Front Hook, Chevelle T-400
- EBH2005 68-72 Silver Rear Hook, Chevelle
- EBH2008 68-72 8 5/8 Hook, T-400
- EBH3002 73-77 Center To Rear Silver Connector, Chevelle
- EBH2017 73-77 Emergency Brake Hook, Chevelle
- EBH1005 73-77 5/16" Lock Nut, Chevelle
- FHC01 73-77 Gold Cadmium Plated C Clip, Chevelle

• E-Brake Hardware - El Camino

- EBH3001 64-72 Olive Green Center Pull, El Camino
- EBH3002 64-67 Center to Rear Silver Connector, El Camino
- EBH2001 68-72 6' Silver Front Hook, Excl. T-400, El Camino
- EBH2001 68-72 Side Hook, El Camino T-400
- EBH2006 68-72 Front Hook, El Camino T-400
- EBH2006 64-67 Front Hook, El Camino Excl. T-400
- EBH2005 64-67 Silver Rear Hook, El Camino
- EBH2005 68-72 Silver Rear Hook, El Camino Excl. T-400

• Rear Brake Cables

- EBC9001 64-67 ... Chevelle, Excl. T-400
- EBC9026 64-67 ... Chevelle, T-400
- EBC9028 64-67 ... El Camino, All Cars
- EBC9007 68-72 ... Chevelle, All Cars
- EBC9029 68-72 ... El Camino, All Cars
- EBC9045 73-77 ... Chevelle, All Cars

DRUM BRAKES

Brake drums are sold individually.



- BD11 66-68 Front Drum, Non-Finned,
- BD12 64-72 Front Drum, Finned
- BD01 67-72 Rear Drum, Finned

BRAKE SHOES

Shoes are sold in sets of four. Upgrade to the Silencer Precision series for quiet, low dust braking and longer shoe life.



- SILENCER PRECISION**
- BS01 67-69 9" Drum Shoes, 2 pr, Standard Organic
 - BS245 64-72 9" Drum Shoes, 2 pr, Silencer Precision

CHEVELLE / EL CAMINO CALIPERS & ROTORS

CALIPERS

New calipers are supplied loaded with pads*, banjo bolts and copper washers. No core charge applies. Mounting pins are provided when applicable. Black and Red powder coating options provide a smooth, finished look that is unaffected by leaking brake fluid. *Rebuilt and new 4 piston calipers do not include pads or hardware. Core charges apply as noted.



- BC1067-68..... 4 Piston, Left, with Exchange
- BC10C67-68..... Core Charge
- BC1167-68..... 4 Piston, Right, with Exchange
- BC11C67-68..... Core Charge
- CB6901 69 Caliper Bolts, Single Piston (ea.)
- BC14N.....69-72.....Left Front, New with pads
- BC15N.....69-72.....Right Front, New with Pads
- BC141569-72.....Red, Black, or Powdercoat (pr)
- BC080973-77.....Red or Black Powdercoat (pr)
- BC12N.....78-88.....Left Front, New with Pads
- BC13N.....78-88.....Right Front, New with Pads
- BC121378-88.....Red or Black Powdercoat (pr)

MINI KITS

Mini kits include a pair of spindles, caliper brackets, and backing plates. These kits are a great value to freshen up the front end on a restoration project, or to build out a drum to disc brake conversion.

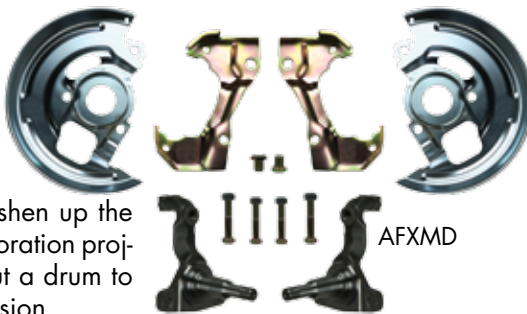

- AFXMD.....69-72.....Mini Conversion Kit, Includes: Spindles, Backing Plates, Caliper Brackets
- AFXMD4.....69-72.....2" Drop, Single Piston Calipers
- AFXMD3.....67-68.....Standard Height, 4 Piston Piston Calipers

DRUM COMPONENTS

Available components include backing plates, adjusters and spring sets. Brake drum hardware kits contain the springs and retainers needed to rebuild an original drum brake assembly. Adjusters are sold in pairs.

- DHK6501 65 11" Drum, Front or Rear Hardware (2 Sets)
- DHK650265-72... 9" Drum, Front Hardware (2 Sets)
- DHK650365-72... 9" Drum, Rear Hardware (2 Sets)
- DHK650465-72... All Cars, Adjusters (2 Pcs)
- DBBP81L.....65-72... 9" Drum Backing Plate, Left
- DBBP81R65-72... 9" Drum Backing Plate, Right

DISC BRAKE PADS

Brake pads are sold in sets of four. Our base line is a midgrade standard offering. Step up to the Silencer Professional line for less dust, quieter braking, and longer pad life.



SILENCER PROFESSIONAL

- DP01 67-68 ... 4 Piston Caliper Pads (2 pr)
- DP02 69-77 ... Single Piston Front Pads (2 pr)
- DP23 78-88 ... Single Piston Front Pads (2 pr)
- DP23 64-88 ... Rear Pads (2 pr), with RSD Rear Disc

ROTORS

Brake rotors are shipped with bearing races installed. A Drilled-Slotted-Zinc Plated option is available on select rotors.



- BR01C..... 67-68 Front Rotor, 4 Piston, 1 Pc Design
- BR69C..... 67-69 Front Rotor, 4 Piston, 2 Pc Design
- BR02C..... 69-72 Front Rotor, 1 Pc Design
- BR03C..... 73-77 Front Rotor
- Call Us! 78..... Front Rotor
- BR22C..... 79-81 Front Rotor
- Call Us! ... 82-88 Front Rotor

SPINDLES

Our spindles are forged steel with precision CNC machining. Two hard to find caliper mounting bolts are included with each pair of spindles. 2" drop installations require caliper bracket and backing plate modifications. All listings are for disc brake systems. Call for drum brake applications.



- DBSP01 67-72 ... Disc Brake Spindles with large bolts (pr)
- DBSP04 67-72 ... 2" Drop Disc Brake Spindles with bolts (pr)
- DBSP7078 .. 73-77 ... 2" Drop Disc Brake Spindles (pr)
- DBSP7987 .. 79-81 ... 2" Drop Disc Brake Spindles (pr)

CHEVELLE / EL CAMINO MASTER CYLINDERS

MASTER CYLINDERS

Master cylinders are completely new units with no core charge. A deep cylinder pocket with a removable plug provides compatibility with manual brakes as well as power-assisted applications.



DBMC01

DBMC09

DBMC11



DBMC51C

DBMC51C

- DBMC08 64-66 ... Drum, Single Outlet, 1" Bore
- DBMC09 67-70 ... Power Disc, 1-1/8" Bore, Deep
- DBMC11 67-69 ... Power Disc, with Bleeders, 1-1/8" Bore, Deep, Exact Repo for '69, Delco Licensed
- DBMC16 67-69 ... Power Disc, with Bleeders, 1-1/8" Bore, Deep, Same as DBMC11 without Casting Marks
- DBMC1970 Power Disc, 1-1/8" Bore, Square with Bleeders
- DBMC01 71-73 ... Power Disc, 1-1/8" Bore, Shallow
- DBMC09C.. 67-69 ... 1-1/8" Bore Chrome
- DBMC05C.. 67-69 ... 1" Bore, 4 Wheel Disc, Chrome
- DBMC51C.. 67-69 ... 1-1/8" Bore, Slimline Flat Top, Chrome
- DBMC56C.. 67-69 ... 1" Bore, Slimline Flat Top, Chrome

CALIPER BRACKETS

Yellow zinc plating provides corrosion protection on these reproduction brackets.

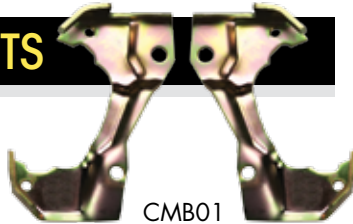

CMB01

- CMB0667-68..... 4 Piston Caliper Brackets (pr)
- CMB0169-72..... Single Piston Caliper Brackets (pr)

POWER VACUUM LINES

Power brake vacuum lines connect the intake manifold fitting to the rubber hose that runs to the power brake booster. Brackets are included as noted.



FBV6703

FBV7005

ADD "S" TO PART NUMBER FOR STAINLESS STEEL

- FBV6703 67-69Small Block
- FBV6705 67-69Big Block (Includes Bracket)
- FBV7005 70.....Big Block (Includes Bracket)
- CBV7101 71-72Small Block, Quadrajel
- CBV7102 71-72307 with 2 BBL
- CBV7105 71-72Big Block (Includes Bracket)
- CBV7301 73.....350, 2 BBL
- FBV7803 78.....350, 4 BBL
- FBV8005 80.....305, 4 BBL

VALVES & BLOCKS

We offer a full line of metering blocks, proportioning valves, distribution blocks and combination valves for factory drum and disc brake applications.

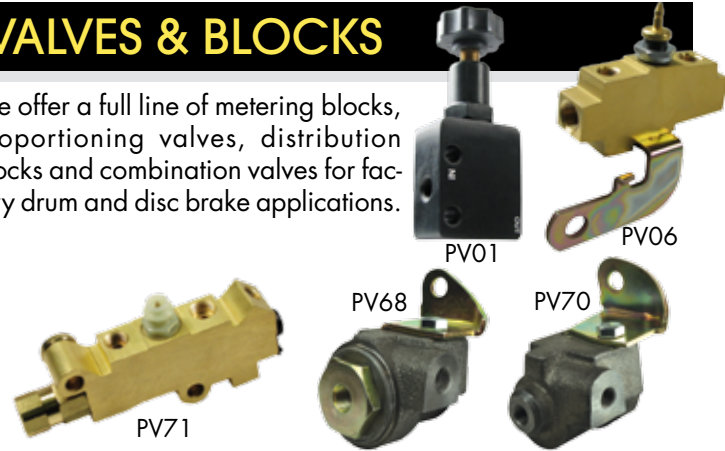

PV01

PV06

PV68

PV70

PV71

- RSBB01 64-68 Rear T block
- PV01All Adjustable Valve, Disc Conversions
- PV0867 Distribution Block
- PV68 67-69 Factory Hold-Off Valve with Bracket
- PV06 68-69 Distribution Block
- PV7070 Factory Hold-Off Valve with Bracket
- CMB7001 ...70 Brake Hold-Off Valve
- PV07 70-72 Distribution Block
- PV71 71-77 Disc/Drum Combination Valve, Brass
- PV71C..... 71-77 Disc/Drum Combination Valve, Chrome
- PV72 71-77 Disc/Disc Combination Valve, Brass
- PV72C..... 71-77 Disc/Disc Combination Valve, Chrome
- PVB78 71-72 Disc Brake Valve Bracket

INTAKE FITTINGS

Intake manifold fittings screw into your factory intake manifold to distribute vacuum to various systems.



IMF68RS

IMF6707

IMF67ZZ

IMF6706

IMF6705

- IMF67ZZ 67-69 ... 3/8" Thread with 1-3/8" Hose Connector
- IMF6705 67-70 ... Big Block, 4-Speed, (Also 68-69 SB with 4 BBL)
- IMF6706 67-70 ... Big Block, Automatic or '70 with 4-Speed and Cowl Induction Hood
- IMF6707 67-70 ... Big Block with AC & Automatic or '70 with Automatic & Cowl Hood
- IMF68RS..... 68-69 ... 3/8" Thread with 2 Ports

BACKING PLATES

Often called dust shields, these plates provide some level of protection from road debris.



DBBP01

DBBP03

- DBBP0367-68..... 4 Piston Backing Plates (pr)
- DBBP01 69-72..... Single Piston Backing Plates (pr)

SLIMLINE BOOSTER MASTER COMBOS

J81315672

The slimline combos offer clean lines and plenty of power in a small package. The 8" dual is our favorite. Mounting brackets included.

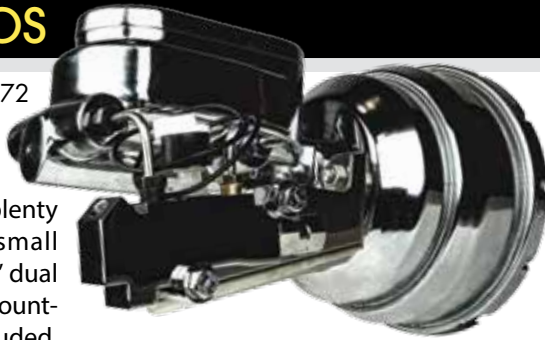

J81315672 TOP VIEW

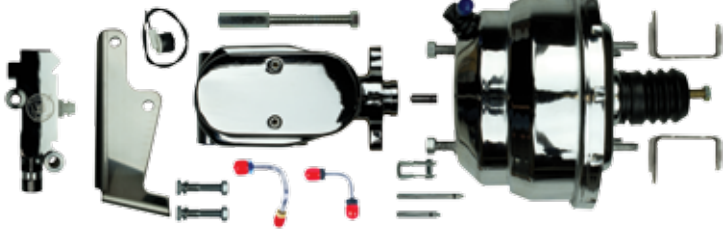

- G81310971 64-72Gold 8" Dual, Disc/Drum
- J81315171..... 64-72Chrome 8" Dual Disc/Drum
- G81310572..... 64-72Gold 8" Dual, Disc/Disc
- J81315672..... 64-72Chrome 8" Dual Disc/Disc
- G91020971 64-72Gold 9" Single, Disc/Drum
- G91020572..... 64-72Gold 9" Single, Disc/Disc

SLIMLINE BOOSTERS

Slimline boosters pack a lot of punch in a small, sleek package. Dual diaphragm versions provide 25% - 35% more assist than their single diaphragm equivalent. The 8" dual is our most popular for clearing big blocks while providing plenty of assist for two or four wheel disc brake systems. Mounting brackets included.



RPB7137



RPB7137C



RPB8131



RPB8131C

- RPB7137 64-727" Dual, Standard Gold
- RPB7137C 64-727" Dual, Chrome Plated
- RPB7137S 64-727" Dual, Polished Stainless
- RPB8131 64-728" Dual, Standard Gold
- RPB8131C 64-728" Dual, Chrome Plated
- RPB8131S 64-728" Dual, Polished Stainless
- RPB9102 64-729" Single, Standard Gold

DELCO BOOSTER MASTER COMBOS

Factory style for 67-81 GM. Can be tight on big block cars. Available with or without Delco stamping. Mounting brackets included.



G10030971

Factory style for 67-72 GM can be tight on big block cars. The 11" is our most popular booster. Available with or without Delco stamping. Mounting brackets included.

G10030971 TOP VIEW

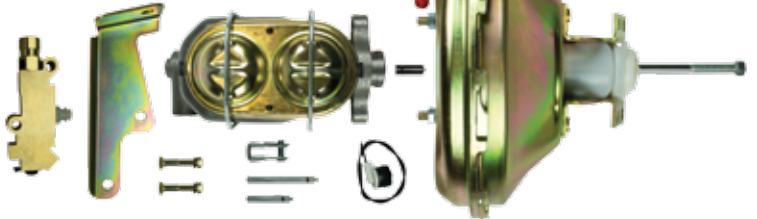

- G91210971 64-72Gold 9" Single Disc/Drum
- J91215171..... 64-72Chrome 9" Single, Disc/Drum
- G91210572 64-72Gold 9" Single Disc/Disc
- J91215672..... 64-72Chrome 9" single, Disc/Disc
- G10030971 67-72Gold 11" Single Disc/Drum
- J10035171..... 67-72Chrome 11" Single, Disc/Drum
- G10030572 67-72Gold 11" Single Disc/Disc
- J10035672..... 67-72Chrome 11" Single, Disc/Disc

DELCO BOOSTERS

Reproductions based on original factory units. GM licensed & feature a Delco Moraine stamping. This logo is available right side up and upside down. Unstamped boosters are of identical quality, but less expensive without the licensing fees. Includes mounting brackets.



RPB1001



RPB1003



RPB1003C

- RPB9121 64-729" Single Gold
- RPB9121C 64-729" Single Chrome
- RPB9016 64-729" Standard Gold, with Delco Stamping
- RPB1001 67-7211" Single, Gold with Delco Stamp
- RPB1008 67-7211" Single, Gold Upside Down Stamp
- RPB1003 67-7211" Single Gold
- RPB1003C 67-7211" Single Chrome

CHEVELLE / EL CAMINO FUEL SYSTEM LINES

FUEL PUMP TO CARB LINES

Fuel pump to carburetor lines connect the fuel pump to the carburetor. Brass blocks and fittings are included as noted. These lines are intended to work only with factory pump, motor, intake and carburetor combinations.



ADD "S" TO PART NUMBER FOR STAINLESS STEEL

- CPC640164 327/300 HP 4 BBL
- CPC640464 23 OCI
- BPC6202.. 64-65 .. 327/300 HP with L-74 Option 2 Pcs.
- CPC6402 . 64-65 .. 327/250 HP 4 BBL
- CPC6501 . 64-65 .. 195, 6 Cylinder
- BPC6602.. 65-67 .. 283 with 2 BBL
- BPC6604.....66 327/275 HP, Carter, Enters Rears
- BPC6609.....66 396 with Quadrajete Line & 90 Elbow
- CPC660266 283 with 4 BBL, 5/16"
- CPC660366 327 with 2 BBL
- CPC660766 with 4 BBL Holley
- VPC6619.....66 396/360 HP with Single Feed Holley, Line & 90 Elbow
- CPC6702 . 66-67 .. 396/350 HP Holley, Single Feed
- FPC6702 .. 66-67 .. Early, 327/210 HP, Before 4-16-67
- FPC6703 .. 67-68 .. 67 Late, 68 All 327/210 HP, After 4/6/67
- FPC6709 .. 67-68 .. 396/325 or 350 HP, Quadrajete
- FPC6775 .. 67-68 .. 396/375 HP, with Block 4 Pcs.
- FPC6701 .. 67-69 .. 230, 6 Cylinder
- FPC6705 .. 67-69 .. 327/275 & 350/295, 5/16"
- FPC6707 .. 67-69 .. 327/275 & 350/295, 3/8"
- FPC690169 350, 2 BBL
- FPC690269 307 & 327, 2 BBL
- FPC697569 396/375 HP, Dual Feed Holley, "Y" Block & 3 Lines
- BPC6903.. 69-70 .. 396 with Quadrajete* 3 Pcs.
- FPC6905 .. 69-70 .. 350, 4 BBL* 3 Pcs.
- CPC700670 LS-6 with Short Pump #747, 3 Lines & T Block, No Return
- CPC700770 LS-6 with Long Pump #768, 3 Lines & T Block, with Return
- FPC700570 LS-5 & L34 with Long Pump
- CPC7101 . 71-72 .. 402, 4 BBL
- CPC7102 . 71-72 .. 350, 4 BBL, 270 HP
- CPC7103 . 71-72 .. 350, 4 BBL Short Water Pump
- CPC720272 350 with 2BBL
- CPC720672 307 with 2 BBL
- CPC730172 350, V-8, 2 BBL
- CPC710572 350, 4 BBL, with Deep Fuel Pump
- CPC730673 6 Cylinder
- CPC720474 350, 2 BBL
- CPC7601 . 76-78 .. 305, 2 BBL
- FPC7801 .. 79-80 .. 305, 2 BBL
- CPC800280 267, 2 BBL
- CPC800480 350, 4 BBL
- CPC810181 229, 6 Cylinder

HOLLEY CARBURETOR PARTS

Components are used to accommodate various configurations of replacement and stock Holley carburetors with dual fuel inlets.

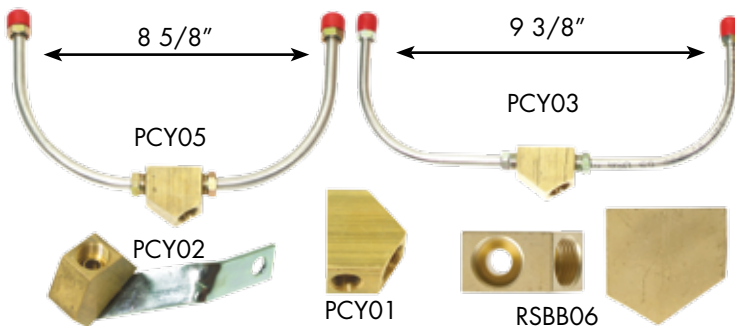

ADD "S" TO PART NUMBER FOR STAINLESS STEEL

- PCY01.... Y Block without Bracket, Brass
- PCY02.... Y Block with Bracket, Brass
- RSBB06 .. Y Block with 3/8" Ports, Used in PCY05, Brass
- PCY03.... Original Dual Feed Holley Carb Lines 3 Pcs., 5/16" Inlets, 9 3/8" Center To Center, with Block
- PCY05.... Replacement Dual Feed Holley Lines 3Pcs., 3/8" Inlets- 8 5/8" Center To Center with Block
- PCY07.... Replacement Dual Feed Holley Lines 3Pcs., 3/8" Inlets- 9 3/8" Center To Center with Block
- PCY04.... T Block For 70 LS-6

THERMAL CHOKE LINES

Thermal choke lines carry heat from the exhaust system to the choke coil on the carburetor. Some applications route thru the intake manifold on their way to the carburetor.

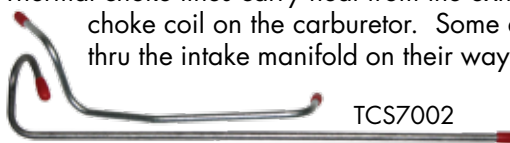

ADD "S" TO PART NUMBER FOR STAINLESS STEEL

- CCH6401... 64-65 ... with 4BBL 2 Pcs.
- TCS7001 70 Big Block with Quadrajete..... 2 Pcs.
- TCS7002 70 Big Block with Holley 2 Pcs.

RETURN FUEL LINES

Return lines carry excess fuel from fuel pump or fuel filter back to the tank. Not all vehicles were equipped with a return line. They are typically made of 1/4" diameter tubing. Multiple piece sets are noted.



ADD "S" TO PART NUMBER FOR STAINLESS STEEL

- CGL6710 67 1/4" Return, Hardtop, (Use with 6403)
- CGL6711 67 1/4" Return, Conv, (Use with 6405)
- CGL68E4 ... 68-69 .. 1/4" Return, El Camino (Use w/ 68E3)
- CGL6922 ... 68-69 .. 1/4" Return, Hardtop, (Use w/ 6923)
- CGL6924 ... 68-69 .. 1/4" Return, Conv, (Use with 6925)
- CGL7029 ... 70-72 .. 1/4" Return, Hardtop, (Use with 7030)
- CGL7032 ... 70-72 .. 1/4" Return, Conv, (Use with 7033)
- CGL71E4 ... 70-72 .. 1/4" Return, El Camino Only

MAIN FUEL LINES

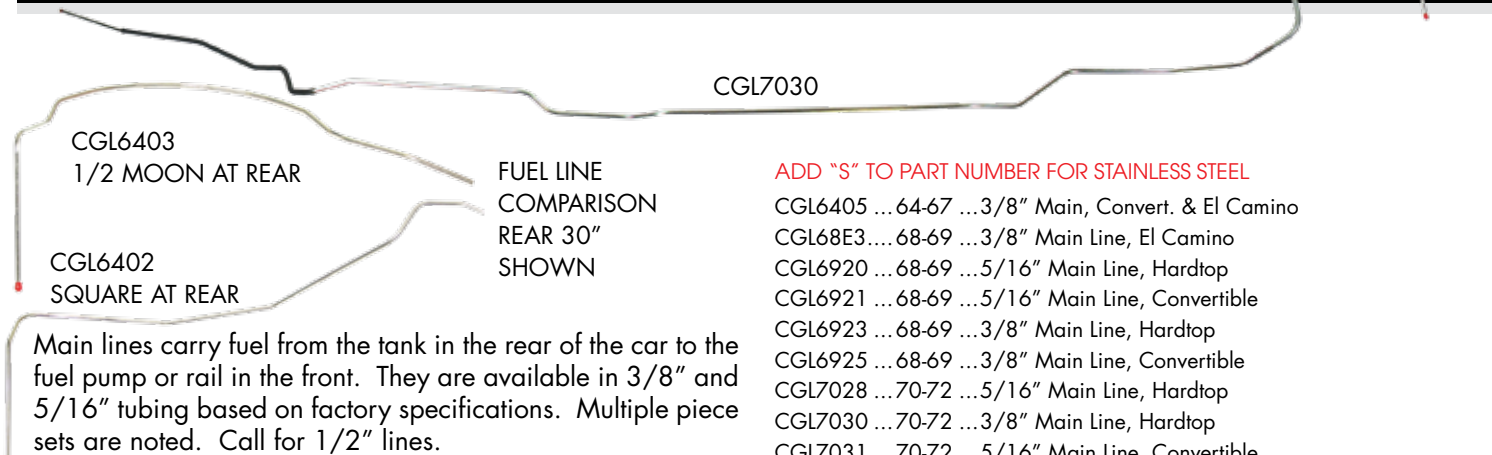

FUEL LINE
COMPARISON
REAR 30"
SHOWN

Main lines carry fuel from the tank in the rear of the car to the fuel pump or rail in the front. They are available in 3/8" and 5/16" tubing based on factory specifications. Multiple piece sets are noted. Call for 1/2" lines.

ADD "S" TO PART NUMBER FOR STAINLESS STEEL

- CGL6406 ... 64-66 ... 5/16" Main Line, Hardtop, Half Moon Over Rear Axle
- CGL6407 ... 64-66 ... 5/16" Main Line, Convertible, Half Moon Over Rear Axle
- CGL6402 ... 64-67 ... 5/16" Main Line, HT, Square at Rear
- CGL6403 ... 64-67 ... 3/8" Main Line, Hardtop
- CGL6404 ... 64-67 ... 5/16" Main Line, Convertible & El Camino

ADD "S" TO PART NUMBER FOR STAINLESS STEEL

- CGL6405 ... 64-67 ... 3/8" Main, Convert. & El Camino
- CGL68E3 ... 68-69 ... 3/8" Main Line, El Camino
- CGL6920 ... 68-69 ... 5/16" Main Line, Hardtop
- CGL6921 ... 68-69 ... 5/16" Main Line, Convertible
- CGL6923 ... 68-69 ... 3/8" Main Line, Hardtop
- CGL6925 ... 68-69 ... 3/8" Main Line, Convertible
- CGL7028 ... 70-72 ... 5/16" Main Line, Hardtop
- CGL7030 ... 70-72 ... 3/8" Main Line, Hardtop
- CGL7031 ... 70-72 ... 5/16" Main Line, Convertible
- CGL7033 ... 70-72 ... 3/8" Main Line, Convertible
- CGL71E3 ... 70-72 ... 3/8" Main, El Camino Only
- CGL7104 ... 71-72 ... 5/16" Main, 4 Door
- CGL7203 ... 72 ... 5/16" Main Line, Wagon 2 Pcs.
- CGL7601 ... 73-76 ... 3/8" Main Line
- CGL75E3 ... 75 ... 3/8" Main, El Camino
- CGL78EC ... 78-87 ... 3/8" Main Line, El Camino 2 Pcs.
- CGL8001 ... 78-80 ... 3/8" Main Line, Malibu
- CGL8207 ... 82-87 ... 5/16" Main Line

TRANSMISSION COOLER LINES

Transmission cooler lines are sold as pairs. Be sure to verify the type of transmission in your project before ordering. These lines are intended to work only with factory motor, transmission, and radiator combinations.

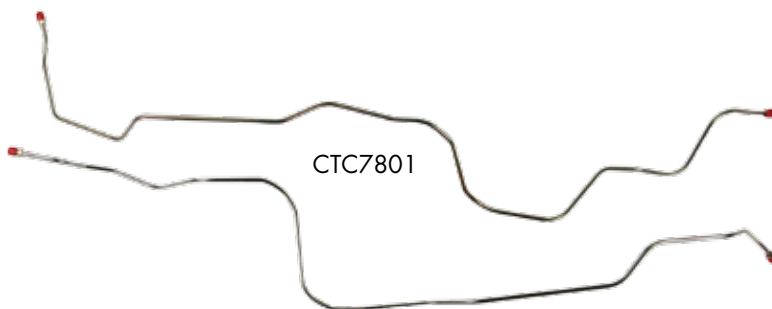

ADD "S" TO PART NUMBER FOR STAINLESS STEEL

- CTC6401 ... 64-65 ... Powerglide, Large Loop
- CTC6601 ... 66-67 ... Powerglide, T 350-400
- CTC67SW ... 67 ... Chevelle Wagon, 396, A/C, T400
- CTC6703 ... 68-72 ... Turbo 350
- CTC6705 ... 68-72 ... Turbo 400
- CTC6801 ... 68-72 ... Powerglide
- CTC7001 ... 70-72 ... 6 Cylinder with Powerglide
- CTC7006 ... 70-72 ... 6 Cylinder with T-350
- CTC7201 ... 72 ... TH400 & 8.5" Spacing @ Radiator
- CTC7303 ... 73-77 ... T 350
- CTC7801 ... 78-81 ... Malibu Turbo 350
- CTC78EC ... 78-82 ... El Camino with 200 HS
- CTC87EC ... 87 ... El Camino, 305, 200-R4 2 Pcs.

TRANSMISSION VACUUM LINES

Transmission vacuum lines connect automatic transmissions to intake vacuum.

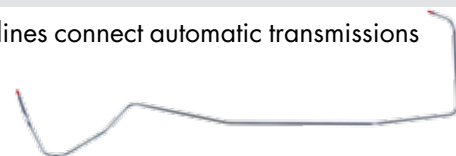

ADD "S" TO PART NUMBER FOR STAINLESS STEEL

- CTV6401 ... 64 ... Powerglide, V-8
- CTV6402 ... 64 ... Powerglide, 6 Cylinder
- CTV6501 ... 65 ... Powerglide, Left Side Modulator
- CTV6605 ... 66 ... 396/360 HP with T-400
- CTV6703 ... 67-68 ... Turbo 350, Left Side Modulator
- CTV6701 ... 67-69 ... Powerglide
- CTV6705 ... 67-69 ... Turbo 400
- CTV6903 ... 69-72 ... Turbo 350, Right Side Modulator
- CTV7101 ... 70-72 ... Turbo 400
- CTV7301 ... 73 ... Turbo 350
- FTV7801 ... 78-81 ... Turbo 350

AIR SHOCK LINES

These pre-bent steel tubes were used to plumb air shock together in factory applications. They are not intended for aftermarket air ride systems.

ADD "S" TO PART NUMBER FOR STAINLESS STEEL

- CAS6404 ... 64-67 ... with G66 Rear Air Shock Option - Chevelle 4 Pcs.
- CAS64EC ... 64-67 ... El Camino, Air Shock Line 4 Pcs.
- CAS70EC ... 68-72 ... El Camino 3 Pcs.

CHEVELLE / EL CAMINO FUEL TANKS

VAPOR RETURN LINES

Emission control systems use these 5/16" lines to handle fuel vapors. Some vehicles use a single front to rear line. Others utilize a charcoal canister and require 3 or 4 additional small lines. Multiple piece sets are noted.

ADD "S" TO PART NUMBER FOR STAINLESS STEEL

- CEM7001..... 70..... Hardtop
- CEM7002..... 70..... Convertible
- CEM70SW .70-72 .. Vapor Line
- CEM7101...71-72 .. Hardtop, Excl. 4 Door
- CEM7102...71-72 .. Convertible
- CEM71EC...71-72 .. El Camino
- CGL7204 72..... Wagon 5/16" Vapor Line
- CGL7603 ...73-76 .. 5/16" Vapor Line
- CEM7601..... 76..... 5/16" Vapor Line
- CFM7802..... 78..... El Camino Vent Line
- CGL78ES....78-87 .. 5/16" Vapor Line, El Camino
- CGL8208 ...82-87 .. 5/16" Vapor Line, Malibu
- CEM8401..... 84..... 5/16" Vapor Line, El Camino

FUEL SENDING UNITS



Sending units include floats, gaskets and snap rings where applicable. Our fuel senders are made of stainless steel and operate on the same ohm range as factory gauges.

NEW 1/2" OPTION

- CSU650165-67.....5/16" Main
- CSU652265-67.....1/2" Main
- CSU650265-67.....3/8" Main
- CSU680168-70.....3/8" Main
- CSU682168-70.....1/2" Main
- CSU680268-70.....3/8" Main & 1/4" Return
- CSU710171-72.....3/8" Main & 1/4" Return

DISTRIBUTOR VACUUM LINES

Distributor vacuum lines supply intake vacuum to the distributor for timing control.



ADD "S" TO PART NUMBER FOR STAINLESS STEEL

- BDV590359-64327/350 HP
- BDV593559-64235 6 Cylinder
- BDV6601 66.....250, 6 Cylinder
- BDV6602 66.....283, 2 BBL
- BDV6604 66.....237, Carter Carb.
- FDV6605..... 66-69Big Block, with Holley Carb.
- FDV6701 67-706 Cylinder
- FDV6703..... 67-70Small Block, 4 BBL
- FDV6707..... 67-72Small Block, 2 BBL
- CDV6805..... 68-72Big Block, 4 BBL
- CDV7102..... 71307, 2 BBL
- CDV7201 72.....350, 4 BBL

FUEL TANKS

Fuel tanks are constructed of Ni-Terne steel. Hardware is not included.



CFT6402



CFT6801

- CFT6401 64-67Chevelle (Excludes El Camino)
- CST6401 64-67Chevelle (Excludes El Camino) with Straps
- CFT6402 64-67El Camino
- CST6402 64-67El Camino with Straps
- CFT6801 68-69Chevelle (Excludes El Camino)
- CST6801 68-69Chevelle (Excludes El Camino) with Straps
- CFT6807 68-70El Camino
- CST6807 68-70El Camino with Straps
- CFT7000 70.....Chevelle without EEC
- CST7000..... 70.....Chevelle without EEC with Straps
- CFT7001 70-72Chevelle (Excludes El Camino) with EEC, 3 Vents on Front Fuel Tank
- CST7001 70-72Chevelle (Excludes El Camino) with EEC, 3 Vents on Front Fuel Tank with Straps
- CFT7002 70-72El Camino with EEC, 3 Vents on Front Fuel Tank
- CST7002 70-72El Camino with EEC, 3 Vents on Front Fuel Tank with Straps

FUEL LINE CLIPS

Fuel line clips hold tubing to the frame or body of the car. Fasteners are included as noted. See page 284-285 for individual clips.

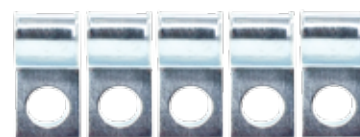

CCS018

- CCS022 64-67 with 5/16" Fuel Line
- CCS023 64-67 with 3/8" Fuel Line
- CCS017 68-72 with 5/16" Fuel Line
- CCS018 68-72 with 3/8" Fuel Line
- CCS019 68-72 with 3/8" Fuel & 1/4" Return

FUEL HOSE KITS

These small rubber hoses and clips are used to connect fuel lines to the fuel pump and sending unit.



FHK3800

- FHK3800.....ALL..... 3/8" x 6", 3/8" x 13", + 4 Green Clamps
- FHK1438.....ALL..... 3/8" x 6", 3/8" x 13", 1/4" x 18" + 4 Green Clamps and 4 Red Clamps

SUSPENSION PARTS

UPPER & LOWER BALL JOINTS

COMING IN 2017



XK5103

XK5108

- XK5103.....64-72.....Lower Ball Joint
- XK5108.....64-72.....Upper Ball Joint
- XK6145.....73-88.....Lower Ball Joint
- XK5208.....73-88.....Upper Ball Joint

INNER & OUTER TIE RODS & SLEEVES

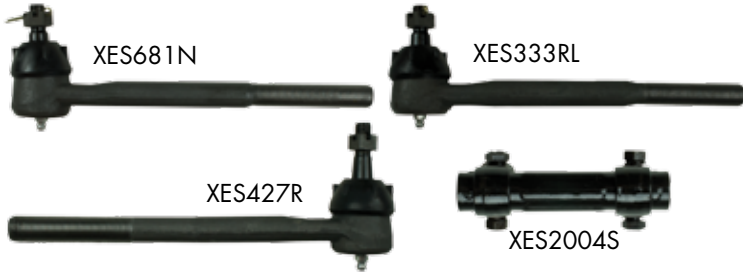

XES681N

XES333RL

XES427R

XES2004S

- XES681N 64-70 Inner
- XES333RL..... 64-70 Outer
- XES2032S 64-70 Adjusting Sleeve
- XES2004S 71-77 Adjusting Sleeve
- XES427R 73-77 Outer

UPPER & LOWER CONTROL ARM BUSHING KITS



XK6076

XK5196

COMING IN 2017

- XK5144.....64-66..... Lower
- XK5196.....64-72..... Upper
- XK6076.....66-72..... Lower, Circular Holes
- XK5149.....66-72..... Lower, Oval Holes
- XK6108..... 73 Upper
- XK6109.....73-77..... Lower
- XK6144.....74-77..... Upper

SWAY BAR LINK KITS



XK5252

- XK5252.....73-77 All
- XK5110..... 64-72 All

FUEL TANK VENT LINES

Fuel tank vent lines allow the air inside the fuel tank to escape as it is filled with fuel. They also prevent pressure from building up due to temperature changes.



CFV6401

- ADD "S" TO PART NUMBER FOR STAINLESS STEEL
- CFV6401.....64-67.....Fuel Tank Vent
 - CFV7601..... 76Malibu, Fuel Tank Vent
 - CFV7802.....78Malibu Wagon

SWAY BAR BUSHINGS



XK5227

- XK5227.....64-67.....All except 396
- XK5241.....68-75.....All
- XK5241.....76-80.....with Tabs on Mounting Clamp
- XK5253.....68-75.....1" or Larger Bar
- XK6161.....76-80.....1" to 1-1/8" Bar with Tabs on Clamp

IDLER ARMS

COMING IN 2017

CIA6801



- CIA640164-67.....Idler Arm with 7/8" Center Link
- CIA6801 64Idler Arm with 3/16" Center Link
- CIA680168-72.....Idler Arm with 3/16" Center Link
- CIA750175-77.....Idler Arm
- CIA7701 77Idler Arm with Var. Ratio Hydraulic Steering
- CIA780178-88.....Idler Arm
- CIA780178-79.....Idler Arm, without Handling Package

STEERING ARMS

COMING IN 2017

- DBSA0164-72..... Steering Arm, 1/2" Bolt Holes (pr)

POWER STEERING LINES

Power steering lines can be either pressure or return feeds in a power steering system.

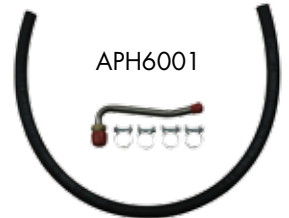

APH6001

- APH6401 64-68.....Small Block Power Steering Hose
- APH6501 65-67.....Big Block External Power Steering Hose
- APH6901 69SS 396 External Power Steering Hose
- APH700170-72.....Big Block Power Steering Hose
- APH6001 AllPower Steering Return Hose Kit



CHEVELLE / EL CAMINO FRONT BRAKE CONVERSIONS

**STREET
SERIES**

FRONT DISC BRAKE CONVERSION KITS

U.S.A. Made
TIMKEN Bearings

FRONT CONVERSIONS INCLUDE:

- 11" Rotors
- Forged Spindles
- Timken Bearings
- New Calipers
- Caliper Brackets
- Organic Pads
- Backing Plates
- Flex Hoses & Clips
- Valve Bracket & Hardware
- Banjo Bolts & Copper Washers
- Dust Caps
- Castle Nuts & Pins
- Washers
- Grease Seals
- Spindle Gaskets
- Steering Arm Bolts
- Master Cylinder
- Combination Valve
- Pedal Rod Extension
- Brake Switch Pigtail

Right Stuff disc conversions are the most complete kits in the industry at the right price. High quality components, professional packaging, and after-sale support by "hands-on" technicians create an unbeatable value. Consider one of our complete brake line packages for a carefree installation.

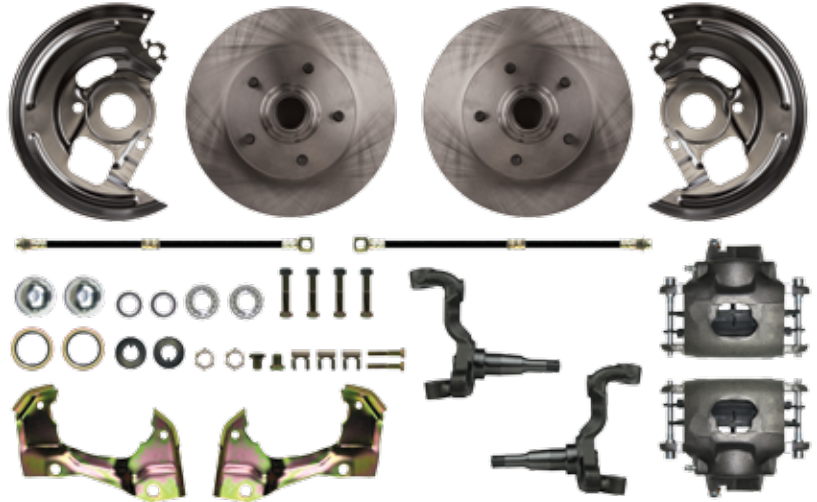

AT-THE-WHEEL FRONT KITS

STOCK HEIGHT FRONT KITS

- AFXWK01C...64-72... At-the-Wheel Disc Conversion Kit
- AFXSD01C....64-72... Manual Disc Conversion Package
- AFXDC01C...64-72... Power Disc Conversion Package 9" Booster
- AFXDC06C...67-72... Power Disc Conversion Package 11" Booster

2" DROP FRONT KITS

- AFXWK01D...64-72... At-the-Wheel Disc Conversion Kit
- AFXSD01D....64-72... Manual Disc Conversion Package
- AFXDC01D...64-72... Power Disc Conversion Package 9" Booster
- AFXDC06D...67-72... Power Disc Conversion Package 11" Booster



Packages include At-the-Wheel Disc Conversion Kit & Master Cylinder with Valve (Manual) or Master Cylinder with Booster and Valve (Power).

POWER PACKAGE

MANUAL PACKAGE

9" or 11" inch booster, call for other diameters

UPGRADES

The next page offers upgrades to fully customize your conversion kit.

SUSPENSION KITS

Standard rubber kits meet O.E. specifications. Polyurethane kits provide better handling and a firmer ride. Poly kits include upgraded control arm bushings, sway bar bushings, and sway bar links. Pre-packaged kits offer huge savings over individual suspension parts. Most kits include the following:

- Lower Ball Joints (2)
- Upper Ball Joints (2)
- Lower Ctrl. Arm Bushings (4)
- Upper Ctrl. Arm Bushings (4)
- Inner Tie Rods (2) (Extra Value)
- Sway Bar Link Kits (2)
- Tie Rod Adj. Sleeves (2)
- Sway Bar Bushings (2)
- Outer Tie Rods (2)



**COMING
IN 2017**

- CSK6501 ... 64-66 ... Kit, Circular Hole in Control Arm, 22-Piece
- CSK6501U ... 64-66 ... Kit, Circular Hole in Ctrl. Arm, 22-Pc (Poly)
- CSK6401 ... 66-72 ... Kit, Circular Hole in Ctrl. Arm, 22-Piece
- CSK6401U ... 66-72 ... Kit, Circular Hole in Ctrl. Arm, 22-Pc (Poly)
- CSK7001 ... 70-72 ... Kit, Oval Hole in Control Arm, 22-Piece
- CSK7001U ... 70-72 ... Kit, Oval Hole in Ctrl. Arm, 22-Piece (Poly)
- CSK730173 Front Rebuild Kit, 22-Piece
- CSK7401 ... 74-75 ... Front Rebuild Kit, 22-Piece
- CSK7601 ... 76-77 ... Front Rebuild Kit, 24 Pcs. with 1-1/8" & 1-3/16" Sway Bar with Tabs on Mounting Clamps
- CSK7801 ... 78-88 ... Front Rebuild Kit, 24 Pcs. with 1" & 1-1/16" Sway Bar without Tabs on Mounting Clamps
- CSK7802 ... 78-88 ... Front Rebuild Kit, 24 Pcs. with 1-1/8" & 1-1/4" Sway Bar without Tabs on Mounting Clamps
- CSK7803 ... 78-88 ... Front Rebuild Kit, 24 Pcs. with 1-5/16" 1-7/16" Sway Bar without Tabs on Mounting Clamps

FRONT DISC BRAKE CONVERSION UPGRADES

STREET SERIES

SHOW'N GO UPGRADE TRIM KITS

These At-the-Wheel Disc Conversion Kits (stock height or 2" drop) include upgraded drilled slotted rotors with zinc plating, powder coated calipers in red or black, and braided stainless hoses.



STOCK HEIGHT SHOW'N GO

AFXWK01CS ... 64-72 ... At-the-Wheel Disc Conversion Kit - Black
 AFXWK01CZ ... 64-72 ... At-the-Wheel Disc Conversion Kit - Red
 AFXSD01CS ... 64-72 ... Manual Disc Conversion Package - Black
 AFXSD01CZ ... 64-72 ... Manual Disc Conversion Package - Red
 AFXDC01CS ... 64-72 ... 9" Power Disc Conversion Package - Black
 AFXDC01CZ ... 64-72 ... 9" Power Disc Conversion Package - Red
 AFXDC06CS ... 67-72 ... 11" Power Disc Conversion Package - Black
 AFXDC06CZ ... 67-72 ... 11" Power Disc Conversion Package - Red

2" DROP SHOW'N GO

AFXWK01DS ... 64-72 ... 2" Drop At-the-Wheel Disc Conv Kit - Black
 AFXWK01DZ ... 64-72 ... 2" Drop At-the-Wheel Disc Conv Kit - Red
 AFXSD01DS ... 64-72 ... 2" Drop - Manual Disc Conv Pkg - Black
 AFXSD01DZ ... 64-72 ... 2" Drop - Manual Disc Conv Pkg - Red
 AFXDC01DS ... 64-72 ... 2" Drop - 9" Power Disc Conv Pkg - Black
 AFXDC01DZ ... 64-72 ... 2" Drop - 9" Power Disc Conv Pkg - Red
 AFXDC06DS ... 67-72 ... 2" Drop - 11" Power Disc Conv Pkg - Black
 AFXDC06DZ ... 67-72 ... 2" Drop - 11" Power Disc Conv Pkg - Red

SHOW STOPPER TRIM PACKAGES

Includes At-the-Wheel Front Disc Conversion Kit (stock height or 2" drop) with natural finish calipers. The Manual Packages get an upgraded chrome plated master cylinder and combination valve with bracket. Power Packages include an upgraded 8" dual chrome booster.



STOCK HEIGHT SHOW STOPPER

AFXSD01CX ... 64-72 ... Manual Disc Conversion Package
 AFXDC01CX ... 64-72 ... Power Disc Conversion Package

2" DROP SHOW STOPPER

AFXSD01DX ... 64-72 ... 2" Drop Manual Disc Conv Package
 AFXDC01DX ... 64-72 ... 2" Drop Power Disc Conv Package

BEST OF SHOW TRIM PACKAGES

Includes At-the-Wheel Front Disc Conversion Kit (stock height or 2" drop) with black or red calipers. The Manual Packages get an upgraded chrome plated master cylinder and combination valve with bracket. Power Packages include an upgraded 8" dual chrome booster.



STOCK HEIGHT BEST OF SHOW

AFXSD01CSX ... 64-72 ... Manual Disc Conversion Package - Black
 AFXSD01CZX ... 64-72 ... Manual Disc Conversion Package - Red
 AFXDC01CSX ... 64-72 ... 8" Power Disc Conv Package - Black
 AFXDC01CZX ... 64-72 ... 8" Power Disc Conv Package - Red

2" DROP BEST OF SHOW

AFXSD01DSX ... 64-72 ... 2" Drop Manual Disc Conv Package - Blk
 AFXSD01DZX ... 64-72 ... 2" Drop Manual Disc Conv Package - Red
 AFXDC01DSX ... 64-72 ... 2" 9" Drop Power Disc Conv Pkg - Black
 AFXDC01DZX ... 64-72 ... 2" 9" Drop Power Disc Conv Pkg - Red



Disc Brake Conversions require special brake lines that fit your new disc conversion setup. Right Stuff offers "No Brainer" Brake Line Kits that include all components needed from your master cylinder back to your rear wheel cylinder or calipers. They include front brake line kit, front to rear line, rear axle lines & flex hose, & clip set.

See page 52 for your application

CHEVELLE / EL CAMINO 4-WHEEL BRAKE CONVERSIONS

**STREET
SERIES**

FOUR WHEEL DISC BRAKE CONVERSION KITS

U.S.A. Made
TIMKEN Bearings

FRONT CONVERSIONS INCLUDE:

- 11" Rotors
- Forged Spindles (OE or 2" Drop)
- Timken Bearings
- New Calipers
- Caliper Brackets
- Organic Pads
- Backing Plates
- Flex Hoses & Clips
- Valve Bracket & Hardware
- Banjo Bolts & Copper Washers
- Dust Caps
- Castle Nuts & Pins
- Washers
- Grease Seals
- Spindle Gaskets
- Steering Arm Bolts
- Master Cylinder
- Combination Valve
- Pedal Rod Extension
- Brake Switch Pigtail

REAR CONVERSIONS INCLUDE:

- 11" Rotors
- Caliper Brackets & Spacers
- Weld-On Hose Brackets
- Flex Hoses
- Backing Plates (Exclusive), not for AFXRD78 or AFXRDM78
- New Loaded Caliper
- E-Brake Cables
- Hardware

Right Stuff disc conversions are the most complete kits in the industry at the right price. High quality components, professional packaging, and after-sale support by "hands-on" technicians create an unbeatable value. Consider one of our complete brake line packages for a carefree installation. See page 47 to verify axle flange measurements for these kits.



Packages include At-the-Wheel Disc Conversion Kits & Master Cylinder with Valve (Manual) or Master Cylinder with Booster and Valve (Power).

POWER PACKAGE

MANUAL PACKAGE

WORKS WITH 15" AND LARGER WHEELS

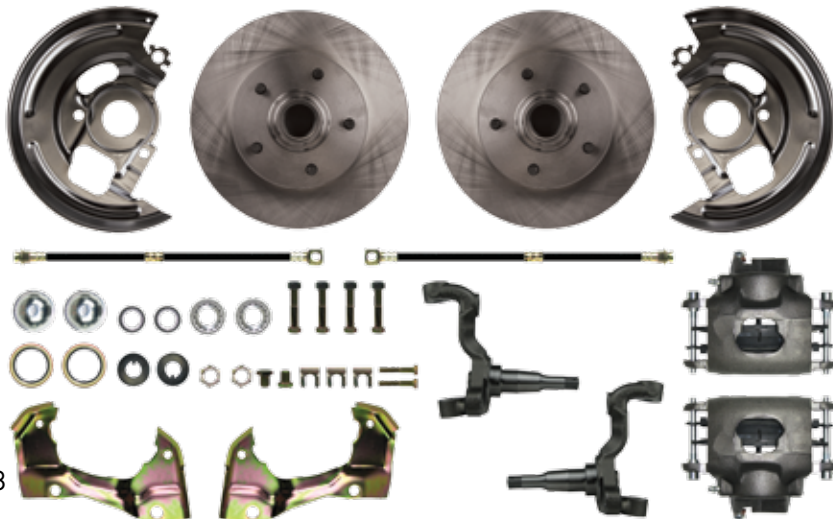

AT-THE-WHEEL FRONT KIT

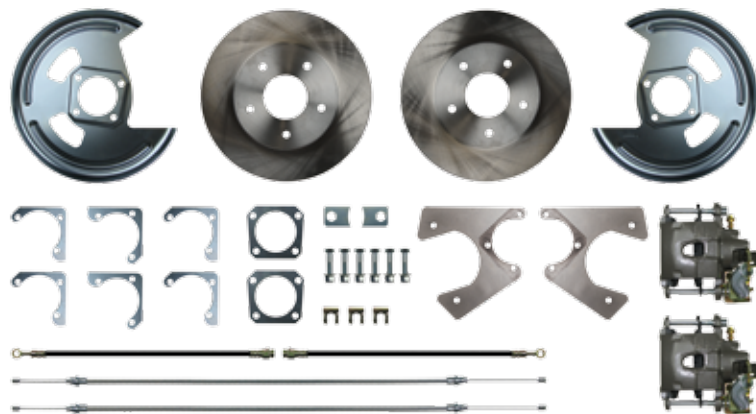

AT-THE-WHEEL REAR KIT

6 3/16" INSIDE ROTOR DIAMETER - 2.78" CENTER HOLE

STOCK HEIGHT 4-WHEEL KITS

- AFXSD41C.....64-72.....Manual Disc Brake Conversion Package
- AFXDC41C64-72.....Power Disc Brake Conv. Pkg, 9" Booster
- AFXDC46C67-72.....Power Disc Brake Conv. Pkg, 11" Booster

2" DROP 4-WHEEL KITS

- AFXSD41D.....64-72.....2" Drop Manual Disc Brake Conv Package
- AFXDC41D64-72.....2" Drop Power Disc Brake Conv. Pkg, 9"
- AFXDC46D67-72.....2" Drop Power Disc Brake Conv. Pkg, 11"



UPGRADES

The next page offers upgrades to fully customize your conversion kit.

CHEVELLE / EL CAMINO 4-WHEEL BRAKE UPGRADES

4-WHEEL DISC BRAKE CONVERSION UPGRADES **STREET SERIES**

SHOW'N GO UPGRADE TRIM KITS

These At-the-Wheel Disc Conversion Kits (stock height or 2" drop) include upgraded drilled slotted rotors with zinc plating, powder coated calipers in red or black, and braided stainless hoses.



STOCK HEIGHT SHOW'N GO

AFXSD41CS.....64-72....Manual Disc Conversion Package - Black
 AFXSD41CZ.....64-72....Manual Disc Conversion Package - Red
 AFXDC41CS64-72....9" Power Disc Conversion Pkg - Black
 AFXDC41CZ64-72....9" Power Disc Conversion Package - Red
 AFXDC46CS67-72....11" Power Disc Conversion Pkg - Black
 AFXDC46CZ67-72....11" Power Disc Conversion Package - Red

2" DROP SHOW'N GO

AFXSD41DS64-72.... 2" Drop - Manual Disc Conv Pkg - Black
 AFXSD41DZ64-72.... 2" Drop - Manual Disc Conv Pkg - Red
 AFXDC41DS.....64-72.... 2" Drop - 9" Power Disc Conv Pkg - Black
 AFXDC41DZ.....64-72.... 2" Drop - 9" Power Disc Conv Pkg - Red
 AFXDC46DS.....67-72.... 2" Drop - 11" Power Disc Conv Pkg - Black
 AFXDC46DZ.....67-72.... 2" Drop - 11" Power Disc Conv Pkg - Red

SHOW STOPPER TRIM PACKAGES

Includes At-the-Wheel Front Disc Conversion Kit (stock height or 2" drop) with natural finish calipers. The Manual Packages get an upgraded chrome plated master cylinder and combination valve with bracket. Power Packages include an upgraded 8" dual chrome booster.

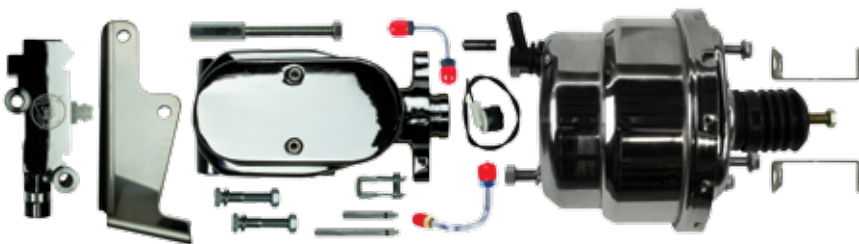

STOCK HEIGHT SHOW STOPPER

AFXSD41CX.... 64-72 ...Manual Disc Brake Conversion Package
 AFXDC41CX ... 64-72 ...Power Disc Brake Conv. Pkg, 8" Booster

2" DROP SHOW STOPPER

AFXSD41DX.... 64-72 ...2" Drop Manual Disc Brake Conv Package
 AFXDC41DX ... 64-72 ...2" Drop Power Disc Brake Conv. Pkg, 8"

BEST OF SHOW TRIM PACKAGES

Includes At-the-Wheel Front Disc Conversion Kit (stock height or 2" drop) with black or red calipers, drilled & slotted rotors & braided stainless hoses. The Manual Packages get an upgraded chrome plated master cylinder and combination valve with bracket. Power Packages include an upgraded 8" dual chrome booster.



STOCK HEIGHT BEST OF SHOW

AFXSD41CSX.... 64-72 ... Manual Disc Brake Conv Package - Black
 AFXSD41CZX.... 64-72 ... Manual Disc Brake Conv Package - Red
 AFXDC41CSX ... 64-72 ... Power Disc Brake Conv. Pkg, 8" - Black
 AFXDC41CZX ... 64-72 ... Power Disc Brake Conv. Pkg, 8" - Red

2" DROP BEST OF SHOW

AFXSD41DSX... 64-72 ..2" Drop Manual Disc Brake Conv Pkg - Blk
 AFXSD41DZX... 64-72 ..2" Drop Manual Disc Brake Conv Pkg - Red
 AFXDC41DSX .. 64-72 ..2" Drop Power Disc Brake Conv, 8" - Black
 AFXDC41DZX .. 64-72 ..2" Drop Power Disc Brake Conv, 8" - Red



OE Steel Only

Stainless Steel

Disc Brake Conversions require special brake lines that fit your new disc conversion setup. Right Stuff offers "No Brainer" Brake Line Kits that include all components needed from your master cylinder back to your rear wheel cylinder or calipers. They include front brake line kit, front to rear line, rear axle lines & flex hose, & clip set.

See page 52 for your application

CHEVELLE / EL CAMINO REAR BRAKE CONVERSIONS

**STREET
SERIES**

REAR DISC BRAKE CONVERSION KITS

NOTE:

FITS FACTORY REAR ENDS CALL
FOR CUSTOM APPLICATIONS

REAR CONVERSIONS INCLUDE:

- 11" Rotors
- Caliper Brackets & Spacers
- Weld-On Hose Brackets
- Flex Hoses
- Backing Plates (Exclusive), not for AFXRD78 or AFXRDM78
- New Loaded Caliper
- E-Brake Cables
- Hardware

Right Stuff disc conversions are the most complete kits in the industry at the right price. High quality components, professional packaging, and after-sale support by "hands-on" technicians create an unbeatable value. Consider one of our complete brake line packages for a carefree installation. See the next page to verify axle flange measurements for these kits.

WANT MATCHING FRONT UPGRADES?

SEE THE NEXT PAGE FOR OUR REAR+2 CONVERSIONS

ATTENTION Before you order, be sure to measure the axle flange on your vehicle.

WORKS WITH 15" AND LARGER WHEELS

6 3/16" INSIDE ROTOR DIAMETER - 2.78" CENTER HOLE

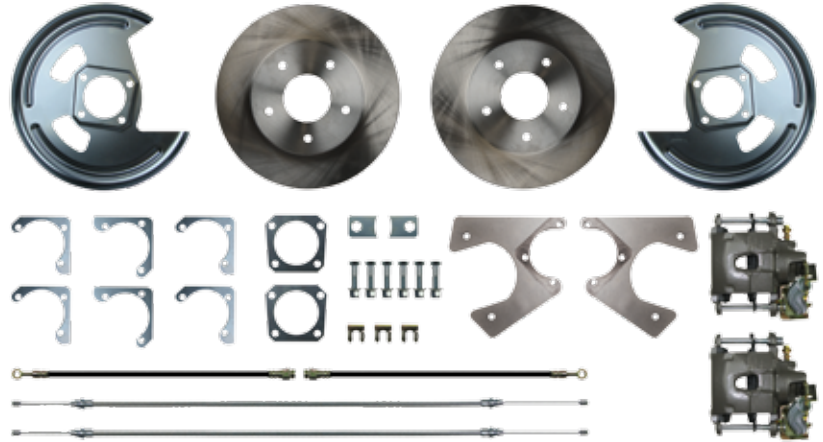

REAR KITS WITH E-BRAKE

AFXRD0164-77... 10 & 12-Bolt Rear Disc Brake Conv Kit
AFXRD7878-88... 10-Bolt Rear Disc Brake Conversion Kit

REAR KITS WITHOUT E-BRAKE

AFXRDM164-77..... 10 & 12-Bolt Rear Disc Brake Conv Kit
AFXRDM7878-88..... 10-Bolt Rear Disc Brake Conversion Kit

REAR DISC BRAKE CONVERSION UPGRADES

**STREET
SERIES**

SHOW'N GO UPGRADE TRIM PACKAGES

These Rear Disc Conversion Kits include upgraded drilled slotted rotors with zinc plating, powder coated calipers in red or black, and braided stainless hoses.



REAR UPGRADE WITH E-BRAKE

AFXRD01S... 64-77... 10 & 12-Bolt Rear Disc Brake Conv Kit - Black
AFXRD01Z... 64-77... 10 & 12-Bolt Rear Disc Brake Conv Kit - Red
AFXRD78S... 78-88... 10-Bolt Rear Disc Brake Conversion Kit - Black
AFXRD78Z... 78-88... 10-Bolt Rear Disc Brake Conversion Kit - Red

REAR UPGRADE W/O E-BRAKE

AFXRDM1S64-77... 10 & 12-Bolt Rear Disc Brake Conv Kit - Black
AFXRDM1Z64-77... 10 & 12-Bolt Rear Disc Brake Conv Kit - Red
AFXRDM78S...78-88... 10-Bolt Rear Disc Brake Conversion Kit - Black
AFXRDM78Z...78-88... 10-Bolt Rear Disc Brake Conversion Kit - Red

 **No Brainer
BRAKE LINE KITS**
DESIGNED FOR DISC CONVERSIONS

Disc Brake Conversions require special brake lines that fit your new disc conversion setup. Right Stuff offers "No Brainer" Brake Line Kits that include all components needed from your master cylinder back to your rear wheel cylinder or calipers. They include front brake line kit, front to rear line, rear axle lines & flex hose, & clip set.

See page 52 for your application

CHEVELLE / EL CAMINO REAR +2 BRAKE CONVERSIONS

**STREET
SERIES**

REAR +2 DISC BRAKE CONVERSION KITS

REAR +2 CONVERSIONS INCLUDE:

- 11" Drilled-Slotted-Zinc Rear Rotors
- Black or Red Rear Powder Coated Calipers
- Caliper Brackets, Spacers, Hardware
- Braided Stainless Rear Hoses
- Weld-On Hose Brackets
- Backing Plates *TRSD Exclusive
- E-Brake Cables

+2 KITS ALSO INCLUDE

- Drilled-Slotted-Zinc Front Rotors
- Black or Red Powder Coated Front Calipers
- Braided Stainless Front Hoses

Right Stuff disc conversions are the most complete kits in the industry at the right price. High quality components, professional packaging, and after-sale support by "hands-on" technicians create an unbeatable value. Get a rear conversion and matching front upgrades with a single part number.

NOTE:
FITS FACTORY
REAR ENDS
CALL FOR CUSTOM
APPLICATIONS



FRONT ROTORS
DRILLED & SLOTTED

WORKS WITH 15" AND LARGER WHEELS

REAR DISC BRAKES + MATCHING FRONT UPGRADES

6 3/16" INSIDE ROTOR DIAMETER - 2.78" CENTER HOLE

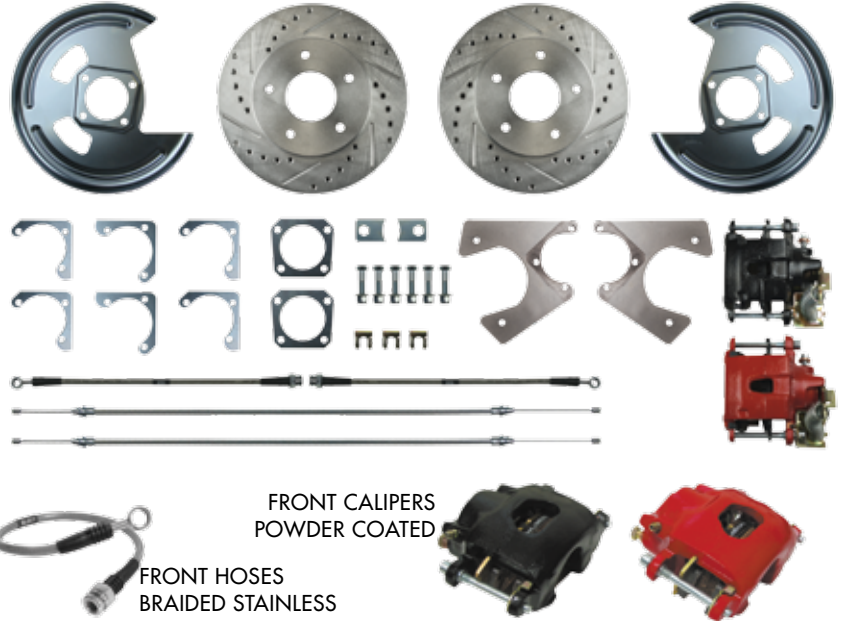

FRONT CALIPERS
POWDER COATED

FRONT HOSES
BRAIDED STAINLESS

REAR +2 KITS WITH E-BRAKE

- A69RD01S 69-72 Black Calipers, Drilled/Slotted
- A69RD01Z 69-72 Red Calipers, Drilled/Slotted
- A73RD01S 73-77 Black Calipers, Drilled/Slotted
- A73RD01Z 73-77 Red Calipers, Drilled/Slotted
- A78RD78S 78 Black Calipers, Drilled/Slotted
- A78RD78Z 78 Red Calipers, Drilled/Slotted
- A79RD78S 79-81 Black Calipers, Drilled/Slotted
- A79RD78Z 79-81 Red Calipers, Drilled/Slotted
- A82RD78S 82-88 Black Calipers, Drilled/Slotted
- A82RD78Z 82-88 Red Calipers, Drilled/Slotted

REAR +2 KITS WITHOUT E-BRAKE

- A69RDM1S..... 69-72 Black Calipers, Drilled/Slotted
- A69RDM1Z 69-72 Red Calipers, Drilled/Slotted
- A73RDM1S..... 73-77 Black Calipers, Drilled/Slotted
- A73RDM1Z 73-77 Red Calipers, Drilled/Slotted
- A78RDM78S..... 78 Black Calipers, Drilled/Slotted
- A78RDM78Z 78 Red Calipers, Drilled/Slotted
- A79RDM78S..... 79-81 Black Calipers, Drilled/Slotted
- A79RDM78Z 79-81 Red Calipers, Drilled/Slotted
- A82RDM78S..... 82-88 Black Calipers, Drilled/Slotted
- A82RDM78Z 82-88 Red Calipers, Drilled/Slotted

AXLE FLANGE DIAGRAMS

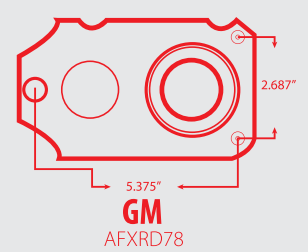
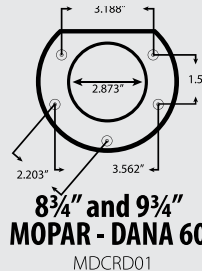
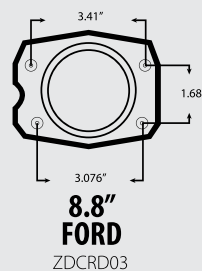
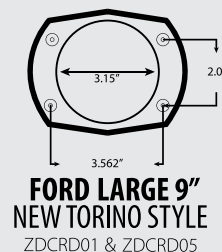
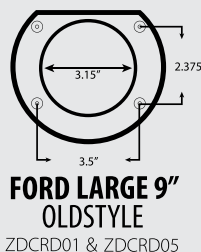
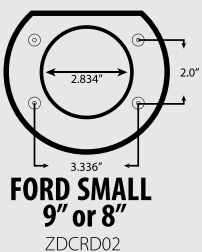
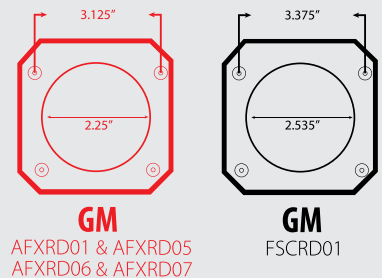
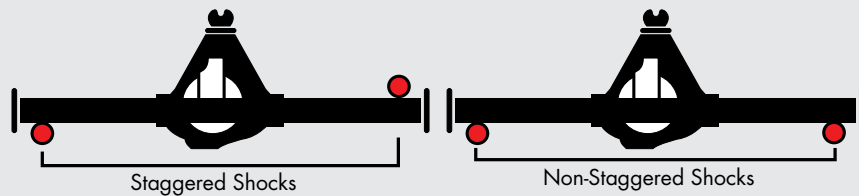



BRAKE•KITS

Fits stock 14" wheel. Bolts to stock drum or disc brake spindles. Minimal offset for better fenderwell clearance. Proprietary rotor.

EZ FIT BRAKE CONVERSION KITS

HALF THE INSTALL TIME

KEEP YOUR FACTORY 14" WHEELS

EZ FIT FRONT CONVERSIONS INCLUDE:

- 10" Rotors with Organic Pads
- New Calipers & Brackets
- Banjo Bolts & Copper Washers
- Dust Caps, Castle Nuts & Pins
- Brake Switch Pigtail
- Master Cylinder (Power/Manual Kits)
- Timken Bearings
- Flex Hoses & Kit
- Grease Seals
- Steering Arm Bolts
- Combination Valve
- 9" Booster (Power)

EZ FIT REAR CONVERSIONS INCLUDE:

- Fits 14" wheels
- Uses proprietary rotor
- Built in e-brake (No cables included)

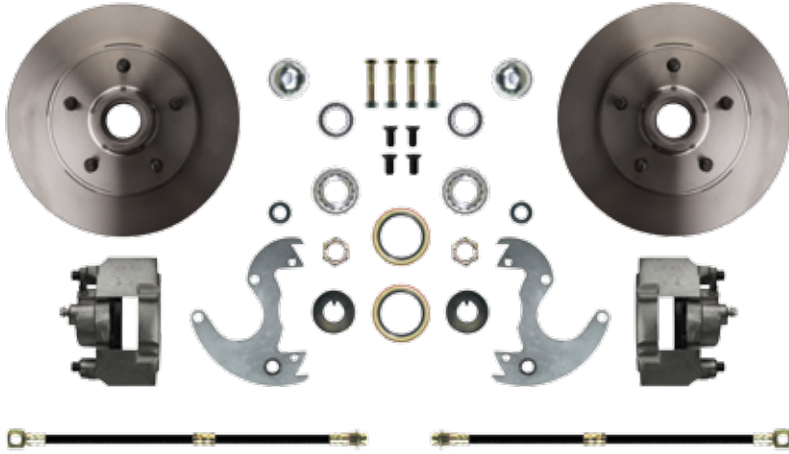

FRONT AT-THE WHEEL KITS

Bolts to your stock drum or disc brake spindles.

Available with standard stock-style rotors or upgraded drilled, slotted & zinc rotors.



Packages include At-the-Wheel Disc Conversion Kits & Master Cylinder with Valve (Manual) or Master Cylinder with Booster and Valve (Power).

POWER PACKAGE

MANUAL PACKAGE

FRONT 14" - STANDARD ROTORS

- AFXWK1464-72..... Front At-the-Wheel Disc Conversion Kit
- AFXSD14.....64-72..... Front Manual Disc Conversion Package
- AFXDC1464-72..... Front Power Disc Conversion Package

FRONT 14" - UPGRADE ROTORS

- AFXWK14A 64-72 Front At-the-Wheel Disc Conversion Kit
- AFXSD14A..... 64-72 Front Manual Disc Conversion Package
- AFXDC14A..... 64-72 Front Power Disc Conversion Package

REAR 14" - STANDARD ROTORS

- AFXRD14.....64-77..... Rear Kit, Non-Staggered

REAR 14" - UPGRADE ROTORS

- AFXRD14A..... 64-77 Rear Kit, Non-Staggered



LOOKING FOR A DIFFERENT BOOSTER + MASTER CYLINDER IN YOUR KIT?

Simply purchase an At-The-Wheel Kit above along with any Booster + Master combo on page 37.

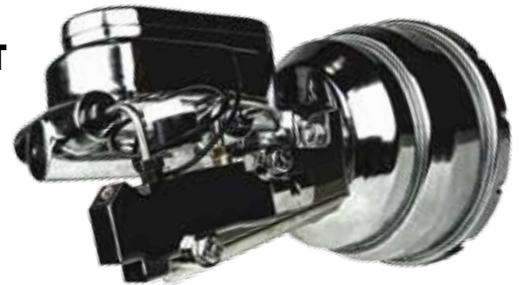

Disc Brake Conversions require special brake lines that fit your new disc conversion setup. Right Stuff offers "No Brainer" Brake Line Kits that include all components needed from your master cylinder back to your rear wheel cylinder or calipers. They include front brake line kit, front to rear line, rear axle lines & flex hose, & clip set.

See page 52 for your application



COMPLETE DISC BRAKE CONVERSION KITS



U.S.A. Made
TIMKEN Bearings

Right Stuff Performance Series disc conversions are the most complete kits in the industry at the right price. Designed for the performance street machine with high quality components, professional packaging, and after-sale support by "hands-on" technicians and many DIY videos at rightstuff create an unbeatable value.

Kits are available as a **Disc Brake Upgrade** that bolts to stock front disc brake spindles, or as an **At-The-Wheel Kit** that includes everything for a front disc brake conversion, and as a **Complete Conversion Kit** which includes everything in the At-The-Wheel Kit with the addition of the master cylinder, booster and prop valve (Power or Manual).

AT-THE-WHEEL CONVERSION KITS INCLUDE:

- 11" Drilled & Slotted Rotors
- Wilwood Dual Piston Calipers
- Caliper Brackets
- Backing Plates
- Timken Bearings
- Castle Nuts & Pins
- Dust Caps
- Forged Spindles
- Organic Pads
- Washers
- Grease Seals
- Spindle Gaskets
- Steering Arm Bolts
- Hardware

COMPLETE CONVERSION KITS ALSO INCLUDE

- Master Cylinder - Chrome or Standard Finish
- Flex Hoses & Clips
- Valve Bracket & Hardware
- Banjo Bolts & Copper Washers
- Combination Valve
- Brake Switch Pigtail
- Pedal Rod Extension



DISC BRAKE UPGRADE KITS INCLUDE (Kit is Designed to Bolt to Stock Disc Brake Spindles)

- Wilwood 2-Piston Aluminum Calipers
- Cross-Drilled & Slotted Zinc Plated Rotors
- Braided Stainless Hoses
- Organic Brake Pads

DISC BRAKE UPGRADE KITS

- RCP69S69-72..... Black 2-Piston Wilwood Calipers
- RCP69Z69-72..... Red 2-Piston Wilwood Calipers
- RCP70S73-77..... Black 2-Piston Wilwood Calipers
- RCP70Z73-77..... Red 2-Piston Wilwood Calipers

WORKS WITH 15" AND LARGER WHEELS

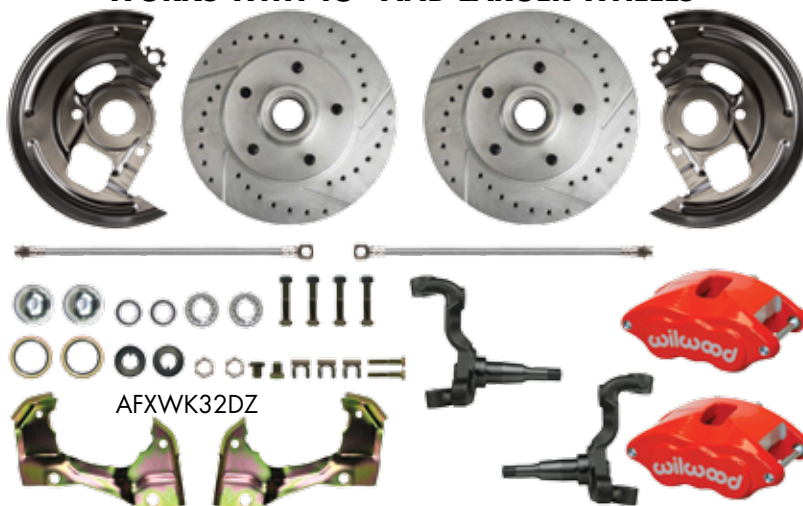

FRONT AT-THE-WHEEL KITS

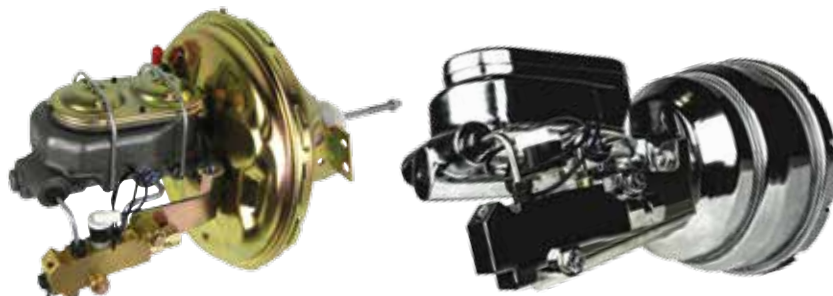

STANDARD PACKAGE

CHROME PACKAGE

Packages include At-the-Wheel Disc Conversion Kits and Chrome or Standard Finish Master Cylinder with Booster and Valve (Power).

AT-THE-WHEEL FRONT DISC KITS

- AFXWK32S..... 64-72... At-the-Wheel Stock Height - Black Wilwood
- AFXWK32Z 64-72... At-the-Wheel Stock Height - Red Wilwood
- AFXWK32DS ... 64-72... At-the-Wheel 2" Drop - Black Wilwood
- AFXWK32DZ ... 64-72... At-the-Wheel 2" Drop - Red Wilwood

STOCK HEIGHT FRONT KITS

- AFXDC32S..... 64-72 ... Standard Booster/Master - Black Wilwood
- AFXDC32Z 64-72 ... Standard Booster/Master - Red Wilwood
- AFXDC32SX.... 64-72 ... Chrome Booster/Master - Black Wilwood
- AFXDC32ZX.... 64-72 ... Chrome Booster/Master - Red Wilwood

2" DROP FRONT KITS

- AFXDC32DS 64-72 .. Standard Booster/Master - Black Wilwood
- AFXDC32DZ 64-72 .. Standard Booster/Master - Red Wilwood
- AFXDC32DSX... 64-72 .. Chrome Booster/Master - Black Wilwood
- AFXDC32DZX .. 64-72 .. Chrome Booster/Master - Red Wilwood

CHEVELLE / EL CAMINO SIGNATURE CONVERSIONS



DISC BRAKE CONVERSION KITS



DESIGNED FOR 17" & LARGER WHEELS

Bold looks define the Signature Series line of brake kits. Large diameter zinc plated rotors, powder coated calipers, fully machined caliper brackets, & braided stainless brake hoses. Only premium quality components make the grade. We back every kit with industry leading technical support. Signature Series kits are amazing brakes at a great price. Add a No Brainer Brake Line Kit for a true bolt-on install.

SIGNATURE SERIES FRONT KIT

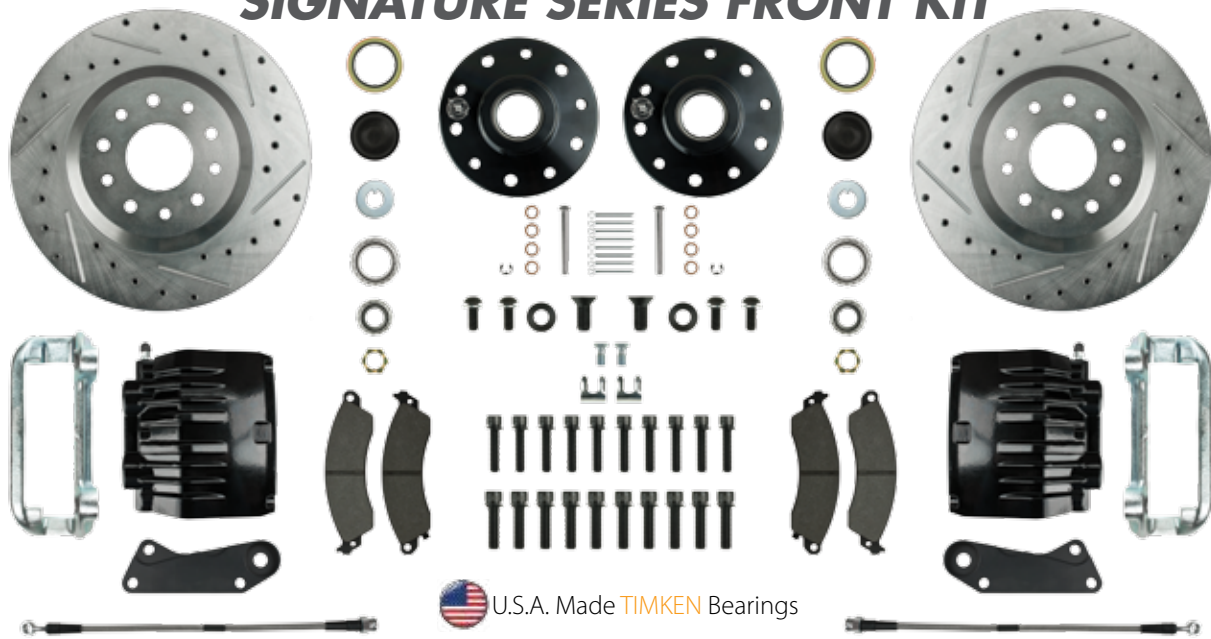

U.S.A. Made **TIMKEN** Bearings

STOCK HEIGHT FRONT KITS

Uses existing drum or disc brake spindles

- AFXWK31CS64-72.....At-the-Wheel Kit - Black Calipers
- AFXWK31CZ64-72.....At-the-Wheel Kit - Red Calipers
- AFXSD31CS.....64-72.....Manual Kit - Black Calipers
- AFXSD31CZ.....64-72.....Manual Kit - Red Calipers
- AFXDC31CS64-72.....Power Kit - Black Calipers
- AFXDC31CZ64-72.....Power Kit - Red Calipers

2" DROP FRONT KITS

Includes new 2" drop spindles

- AFXWK31DS 64-72 At-the-Wheel Kit - Black Calipers
- AFXWK31DZ 64-72 At-the-Wheel Kit - Red Calipers
- AFXSD31DS..... 64-72 Manual Kit - Black Calipers
- AFXSD31DZ..... 64-72 Manual Kit - Red Calipers
- AFXDC31DS 64-72 Power Kit - Black Calipers
- AFXDC31DZ 64-72 Power Kit - Red Calipers

STOCK HEIGHT 4-WHEEL KITS

Stock Height - Non-Staggered Shocks

- AFXWK51CS 64-72 At-the-Wheel Kit - Black Calipers
- AFXWK51CZ 64-72 At-the-Wheel Kit - Red Calipers
- AFXSD51CS..... 64-72 Manual Kit - Black Calipers
- AFXSD51CZ..... 64-72 Manual Kit - Red Calipers
- AFXDC51CS 64-72 Power Kit - Black Calipers
- AFXDC51CZ 64-72 Power Kit - Red Calipers

2" DROP 4-WHEEL KITS

Stock Height - Non-Staggered Shocks

- AFXWK51DS 64-72 At-the-Wheel Kit - Black Calipers
- AFXWK51DZ 64-72 At-the-Wheel Kit - Red Calipers
- AFXSD51DS..... 64-72 Manual Kit - Black Calipers
- AFXSD51DZ..... 64-72 Manual Kit - Red Calipers
- AFXDC51DS 64-72 Power Kit - Black Calipers
- AFXDC51DZ 64-72 Power Kit - Red Calipers

CHEVELLE / EL CAMINO SIGNATURE CONVERSIONS

X-TRIM DISC BRAKE CONVERSION UPGRADES



Start turning heads with a show finished upper assembly. Manual kits get a chrome plated master cylinder and combination valve with bracket. Power kits also include an 8" dual chrome booster.

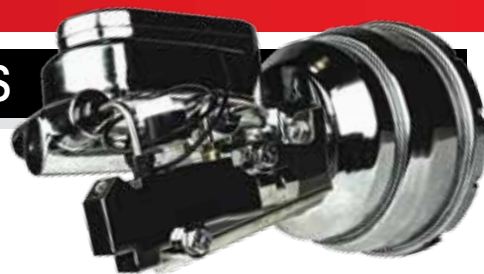

STOCK HEIGHT FRONT KITS

Uses existing drum or disc brake spindles

- AFXSD31CSX 64-72Manual Kit - Black Calipers
- AFXSD31CZX 64-72Manual Kit - Red Calipers
- AFXDC31CSX 64-72Power Kit - Black Calipers
- AFXDC31CZX 64-72Power Kit - Red Calipers

2" DROP FRONT KITS

Includes new 2" drop spindles

- AFXSD31DSX 64-72Manual Kit - Black Calipers
- AFXSD31DZX 64-72Manual Kit - Red Calipers
- AFXDC31DSX 64-72Power Kit - Black Calipers
- AFXDC31DZX 64-72Power Kit - Red Calipers

STOCK HEIGHT 4-WHEEL KITS

Stock Height - Non-Staggered Shocks

- AFXSD51CSX 64-72Manual Kit - Black Calipers
- AFXSD51CZX 64-72Manual Kit - Red Calipers
- AFXDC51CSX 64-72Power Kit - Black Calipers
- AFXDC51CZX 64-72Power Kit - Red Calipers

2" DROP 4-WHEEL KITS

Stock Height - Non-Staggered Shocks

- AFXSD51DSX 64-72Manual Kit - Black Calipers
- AFXSD51DZX 64-72Manual Kit - Red Calipers
- AFXDC51DSX 64-72Power Kit - Black Calipers
- AFXDC51DZX 64-72Power Kit - Red Calipers



REAR DISC BRAKE CONVERSION KITS

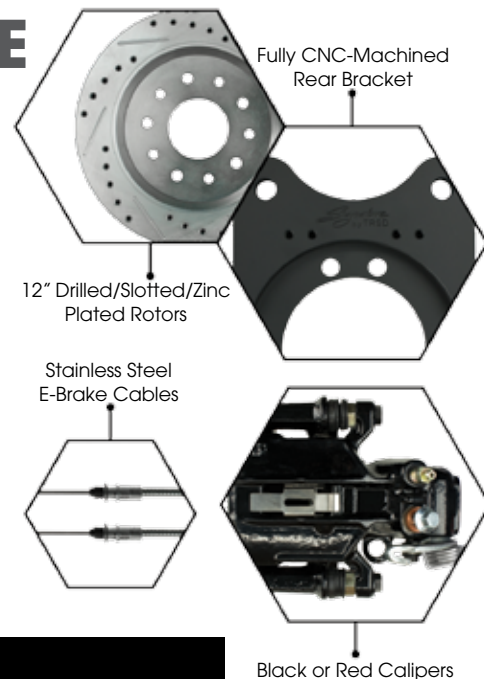
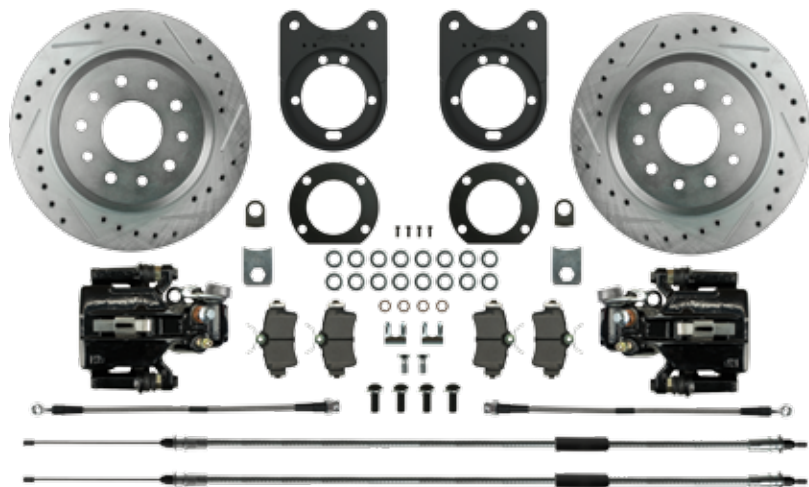

KITS FIT AXLES WITH 3-1/8" FLANGE ONLY

REAR DISC CONVERSION KITS

AFXRD31S 64-77 Rear Disc Conversion - Black

AFXRD31Z 64-77 Rear Disc Conversion - Red





No Brainer BRAKE LINE KITS

DESIGNED FOR DISC CONVERSIONS

When you add disc brakes to your car you are using a new valve that has different size ports pointing in different directions. Even if your lines are brand new or great originals, you are going to have issues trying to use them. Our No Brainer Brake Line Kit fixes all these issues from your master cylinder all the way back to your rear wheel cylinders or rear calipers. We give you all the lines to complete the installation. We also include the rear flex hose and a full clip set to install your lines. Extremely discounted prices and great instructions make this kit a No Brainer.

NOTE: El Camino MUST order convertible line set.

SIMPLIFY YOUR DISC BRAKE CONVERSION INSTALLATION WITH ALL OF THE BRAKE LINES YOU WILL NEED.

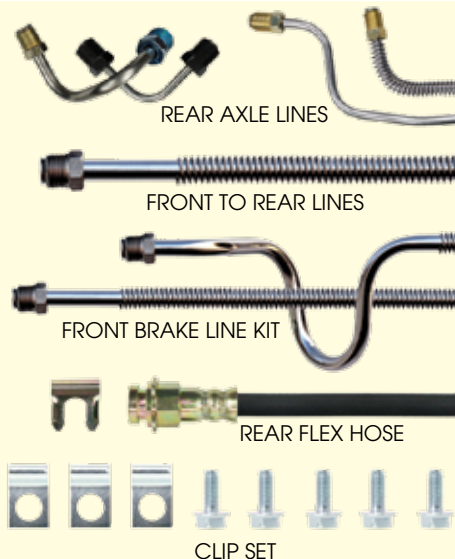

MANUAL - NO VACUUM BOOSTER FRONT DISC/REAR DRUM LINES

- COM64H2 64-67 Hardtop, OE Steel Brake Line Kit
- CSM64H2 64-67 Hardtop, Stainless Steel Brake Line Kit
- COM64C2 64-67 Convertible, OE Steel Brake Line Kit
- CSM64C2 64-67 Convertible, Stainless Steel Brake Line Kit
- COM68H2 1968..... Hardtop, OE Steel Brake Line Kit
- CSM68H2 1968..... Hardtop, Stainless Steel Brake Line Kit
- COM68C2 1968..... Convertible, OE Steel Brake Line Kit
- CSM68C2 1968..... Convertible, Stainless Steel Brake Line Kit
- COM69H2 69-72 Hardtop, OE Steel Brake Line Kit
- CSM69H2 69-72 Hardtop, Stainless Steel Brake Line Kit
- COM69C2 69-72 Convertible, OE Steel Brake Line Kit
- CSM69C2 69-72 Convertible, Stainless Steel Brake Line Kit

POWER - WITH VACUUM BOOSTER FRONT DISC/REAR DRUM LINES

- COP64H2 64-67 Hardtop, OE Steel Brake Line Kit
- CSP64H2 64-67 Hardtop, Stainless Steel Brake Line Kit
- COP64C2 64-67 Convertible, OE Steel Brake Line Kit
- CSP64C2 64-67 Convertible, Stainless Steel Brake Line Kit
- COP68H2 1968..... Hardtop, OE Steel Brake Line Kit
- CSP68H2 1968..... Hardtop, Stainless Steel Brake Line Kit
- COP68C2 1968..... Convertible, OE Steel Brake Line Kit
- CSP68C2 1968..... Convertible, Stainless Steel Brake Line Kit
- COP69H2 69-72 Hardtop, OE Steel Brake Line Kit
- CSP69H2 69-72 Hardtop, Stainless Steel Brake Line Kit
- COP69C2 69-72 Convertible, OE Steel Brake Line Kit
- CSP69C2 69-72 Convertible, Stainless Steel Brake Line Kit

4-WHEEL DISC LINES

- COM64H4 64-67 Hardtop, OE Steel Brake Line Kit
- CSM64H4 64-67 Hardtop, Stainless Steel Brake Line Kit
- COM64C4 64-67 Convertible, OE Steel Brake Line Kit
- CSM64C4 64-67 Convertible, Stainless Steel Brake Line Kit
- COM68H4 1968..... Hardtop, OE Steel Brake Line Kit
- CSM68H4 1968..... Hardtop, Stainless Steel Brake Line Kit
- COM68C4 1968..... Convertible, OE Steel Brake Line Kit
- CSM68C4 1968..... Convertible, Stainless Steel Brake Line Kit
- COM69H4 69-72 Hardtop, OE Steel Brake Line Kit
- CSM69H4 69-72 Hardtop, Stainless Steel Brake Line Kit
- COM69C4 69-72 Convertible, OE Steel Brake Line Kit
- CSM69C4 69-72 Convertible, Stainless Steel Brake Line Kit

4-WHEEL DISC LINES

- COP64H4 64-67 Hardtop, OE Steel Brake Line Kit
- CSP64H4 64-67 Hardtop, Stainless Steel Brake Line Kit
- COP64C4 64-67 Convertible, OE Steel Brake Line Kit
- CSP64C4 64-67 Convertible, Stainless Steel Brake Line Kit
- COP68H4 1968..... Hardtop, OE Steel Brake Line Kit
- CSP68H4 1968..... Hardtop, Stainless Steel Brake Line Kit
- COP68C4 1968..... Convertible, OE Steel Brake Line Kit
- CSP68C4 1968..... Convertible, Stainless Steel Brake Line Kit
- COP69H4 69-72 Hardtop, OE Steel Brake Line Kit
- CSP69H4 69-72 Hardtop, Stainless Steel Brake Line Kit
- COP69C4 69-72 Convertible, OE Steel Brake Line Kit
- CSP69C4 69-72 Convertible, Stainless Steel Brake Line Kit

PROPORTIONING VALVES

DOES YOUR VALVE
LOOK LIKE THIS?



When upgrading to disc brakes or keeping them stock, make sure your proportioning valve is designed for the brake system that is specific to your vehicle.



- PVK71 Disc/Drum Proportioning Valve - Brass Finish
- PVK72 Disc/Disc Proportioning Valve - Brass Finish
- PVK71C..... Disc/Drum Proportioning Valve - Chrome Finish
- PVK72C..... Disc/Disc Proportioning Valve - Chrome Finish

FRONT BRAKE LINE KITS

Front brake line kits consist of all brake lines under the hood. This includes the master cylinder to the distribution, combination or metering valve. The left and right front lines that run to the front flex hoses are also included. Call for individual component pricing. These line kits are for vehicles with factory brake systems.



ADD "S" TO PART NUMBER FOR STAINLESS STEEL

- CVK6709 67-69 Corvaair Manual Drum
- CVK7101 71-72 All Cars
- CVK7301 73-75 All Cars
- CVK7501 75..... Power Disc, Cosworth
- CVK7601 76..... Manual Disc

FRONT TO REAR BRAKE LINES

Front to rear brake lines go from the distribution, combination or metering valve along the length of the vehicle to the rear flex hose. Lines are manufactured in 1 or 2 pieces based on factory specifications.



ADD "S" TO PART NUMBER FOR STAINLESS STEEL

- CVI7101 71-75All Cars
- CVI7501 75.....Cosworth
- CVI7601 76.....All Cars

REAR AXLE BRAKE LINES

Rear axle brake lines include a pair of lines that run across the rear axle housing. These lines connect the wheel cylinders or calipers to the flex hose in the middle of the rear end. These lines work with original housings that use factory brakes. Modifications such as rear disc brakes or narrowed rear ends will likely require special lines. Call for more information.



ADD "S" TO PART NUMBER FOR STAINLESS STEEL

- CRV750271-76.... All Cars
- CRV7503 75 Cosworth
- CVR7503 75 Cosworth Vega Rear Axle

MAIN FUEL LINES

Main lines carry fuel from the tank in the rear of the car to the fuel pump or rail in the front. They are available in 3/8" and 5/16" tubing based on factory specifications. Multiple piece sets are noted. Call for 1/2" lines.

ADD "S" TO PART NUMBER FOR STAINLESS STEEL

- CVG7101.....71 5/16" Main Line
- CVG7401.....74 3/8" Main Line
- CVG7402.....74 1/4" Return Line
- CVG7501.....75 1/4" Return Line
- CVG7502.....75 3/8" Main Line
- CVG7503.....75 5/16" Vapor Line
- CVG7504.....75 5/16" Engine Compartment Vapor Line
- CVG7505.....75 Cosworth, 3/8" Main Line 2 Pcs.
- CVG7506.....75 Cosworth, 1/4" Return Line
- CVG7507.....75 Cosworth, 1/4" Vapor Line
- CVG7600.....76 1/4" Vapor Return Line
- CVG7601.....76 1/4" Return Line
- CVG7602.....76 3/8" Main Line
- CVG7603.....76 5/16" Vapor Line
- CVG7604.....76 5/16" Engine Compartment Vapor Line

FUEL TANK VENT LINES

Fuel tank vent lines allow the air inside the fuel tank to escape as it is filled with fuel. They also prevent pressure from building up due to temperature changes.

- CVT7601.....76Vent Line - OE Steel
- CVT7601S.....76Vent Line - Stainless

FUEL PUMP TO CARB LINES

Fuel pump to carburetor lines connect the fuel pump to the carburetor. Brass blocks and fittings are included as noted. These lines are intended to work only with factory pump, motor, intake and carburetor combinations.

- CVP6709.....67-69..... Corvaair 2 x 1 - OE Steel
- CVP6709S.....67-69..... Corvaair 2 x 1 - OE Stainless

LINES NOT LISTED?

If you need a line that is not listed in our catalog and you have a good original, you may qualify for free lines. Call us today for details.



NOVA BRAKE LINES

FRONT BRAKE LINE KITS

Front brake line kits consist of all brake lines under the hood. This includes the master cylinder to the distribution, combination or metering valve. The left and right front lines that run to the front flex hoses are also included. Call for individual component pricing. These line kits are for vehicles with factory brake systems.



XKT7201

XKT6202

ADD "S" TO PART NUMBER FOR STAINLESS STEEL

- XKT6201 62-64 Standard Drum
- XKT6202 62-64 Power Drum
- XKT6501 65-66 Standard Drum
- XKT6502 65-66 Power Drum
- XKT6701 67 Standard Drum
- XKT6703 67 Standard Disc
- XKT6704 67 Power Disc
- FKT6701 68 Standard Drum
- FKT6703 68 Power Drum
- FKT6705 68 Manual Disc
- FKT6707 68 Power Disc
- XKT6905 69 Power Disc
- FKT6903 69-74 Power Drum
- XKT6907 69-73 Manual Drum
- XKT7001 70 Power Disc
- XKT7002 70 Manual Disc
- XKT7201 71-74 Power Disc
- XKT7401 74 Standard Drum
- XKT7501 75 Power Disc
- XKT7601 76-77 Power Disc
- XKT7801 78 Power Disc

REAR AXLE BRAKE LINES

Rear axle brake lines include a pair of lines that run across the rear axle housing. These lines connect the wheel cylinders or calipers to the flex hose in the middle of the rear end. These lines work with original housings that use factory brakes. Modifications such as rear disc brakes or narrowed rear ends will likely require special lines. Call for more information.



ADD "S" TO PART NUMBER FOR STAINLESS STEEL

- XRA6202 62-65 All Cars 2 Pcs.
- XRA6602 66-67 All Cars 2 Pcs.
- FRA6802 68 Mono-Leaf Spring 2 Pcs.
- FRA6805 68 Multi-Leaf Spring 2 Pcs.
- XRA6902 69-73 All Cars 2 Pcs.
- XRA7402 74 All Cars 2 Pcs.
- XRA7502 75 All Cars 2 Pcs.
- XRA7601 76-77 All Cars 2 Pcs.
- XRA7801 78 All Cars 2 Pcs.

DISC CALIPER LINES

Front disc caliper lines connect the front flex hoses to the calipers. They were typically used on 4 piston calipers in the late 1960's. Several fitting sizes were available from the factory. Please verify fitting sizes before ordering as rebuilt calipers may not match the originals.

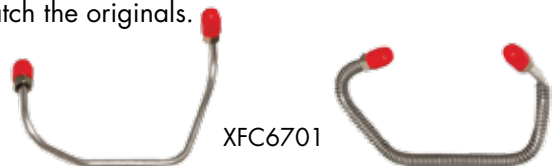

XFC6701

ADD "S" TO PART NUMBER FOR STAINLESS STEEL

- XFC6701 67 ... Pair 1/2" Left Port & 7/16" Right Port - OE Steel
- XFC6701S 67 ... Pair 1/2" Left Port & 7/16" Right Port - Stainless



FRONT TO REAR LINES

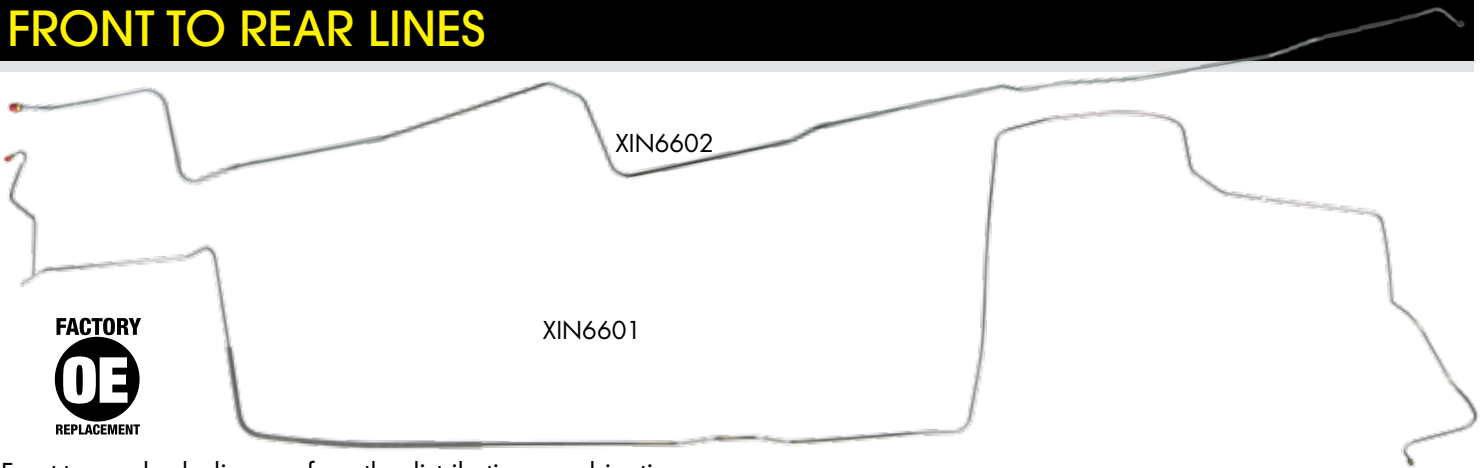

Front to rear brake lines go from the distribution, combination or metering valve along the length of the vehicle to the rear flex hose. Manufactured in 1 or 2 pieces based on factory specifications.

ADD "S" TO PART NUMBER FOR STAINLESS STEEL

- XIN6201 62-65 All
- XIN6601 66 L-79 Only
- XIN6602 66 All, Except L-79
- XIN6701 67 All
- XIN6801 68 All
- XIN6901 69 Power Disc or Drum
- XIN6902 69-70 Power Disc 2 Pcs.

ADD "S" TO PART NUMBER FOR STAINLESS STEEL

- XIN6903 69-73 Manual Drum
- XIN7001 70 All Power
- XIN7105 71 Power Disc
- XIN7103 71-73 Power Drum
- XIN7201 72-73 Power Disc
- XIN7202 72-73 Manual Drum
- XIN7402 74 Power Disc
- XIN7501 75 All Power
- XIN7601 76-77 Power Disc
- XIN7801 78 Power Disc

FRONT FLEX HOSES

Front flex hoses provide a flexible connection from the body or frame to the front calipers or wheel cylinders as they move during suspension travel. Choose between O.E. rubber or braided stainless steel. All of our hoses are D.O.T. approved. Hoses are priced individually.



ADD "S" TO PART NUMBER FOR STAINLESS STEEL

- FH35 62-66 Front Drum
- FH37 67 Front Drum
- FH42 67 Front Disc
- FH02 68-73 Front Drum
- FH03 69-72 Front Disc
- FH167 73-75 Left Front
- FH168 73-75 Right Front
- FH163 76 Front
- FH08 77-78 Front
- FH09 79 Front

REAR FLEX HOSES

Rear flex hoses carry brake fluid between the body of the car and the rear. Hoses are available in O.E. rubber and braided stainless steel. 'T' blocks are attached whenever factory correct. All of our hoses are D.O.T. approved. Prices are per hose.



ADD "S" TO PART NUMBER FOR STAINLESS STEEL

- FH32 62-65 Rear
- FH04 66-67 Rear
- FH05 68 Rear
- FH06 69-72 Rear
- FH15 73 Rear
- FH12 74-75 Rear
- FH76 76 Rear
- FH13 77-79 Rear

FLEX HOSE BRACKETS

These brackets and hardware are used to secure flex hoses to various parts of the vehicle. Front brackets are sold in pairs.

- RSBK67 67-68 Front Hose to 4 Piston Caliper Brackets (pr
- RSBK01 67-69 Distribution Block Bracket, Under Master
- RSBK69 69-74 Front Flex Hose Frame Brackets,
Includes 2 Brackets, Clip, & 2 Gromets
- RSBK09 69-74 12 Bolt Rear Hose Bracket



NOVA E-BRAKE COMPONENTS

E-BRAKE CABLES

Parking brake cable sets contain all the individual cables and hardware needed to restore the system. Front, rear, and intermediate cables are also sold individually. Sold in O.E. mild steel and stainless steel. Complete kits and rear cables listed in this area are for rear drum vehicles. If you have rear disc, call for options. While supplies last. SEE PAGE 286 FOR PICTURES OF E-BRAKE HARDWARE



• Complete Cable Kits

RSBCX0164-67..... All Cars
 RSBCX0268-74..... All Cars
 RSBCX0375-79..... All Cars*

*We are in need of original samples in good condition for these sets. Your order will be discounted if you are the first to get your set to us.

• E-Brake Hardware

EBH300164-77..... Olive Green Center Pull, Chevelle
 RSCLP2364-74..... Parking Brake Clip - Black
 EBH100164-74..... Jam Nut
 EBH300268-74..... Center to Rear Silver Connector
 EBH200368-74..... 12" Silver Hook

• Rear Brake Cables

EBC900564-67..... Nova, All
 EBC900468-74..... Nova, All

• Front Brake Cables

EBC700364-67..... Nova, All
 EBC700268-74..... Nova, All

• Intermediate Brake Cables

EBC800468-74..... Nova, All

BRAKE DRUMS

Brake drums are sold individually.



BD1164-68..... Front Drum, Non-Finned
 BD1264-74..... Front Drum, Finned
 BD0164-74..... Rear Drum, Finned

WHEEL CYLINDERS

Wheel cylinders are priced individually. Hardware is not included.



WC2865-67..... Left Front
 WC2965-67..... Right Front
 WC0365-75..... Rear
 WC0168-69..... Left Front
 WC0268-69..... Right Front
 WC0476-79..... Rear

BRAKE SHOES

Shoes are sold in sets of four. Upgrade to the Silencer Precision series for quiet, low dust braking and longer shoe life.



SILENCER PRECISION

BS0168-74..... 9" Drum Shoes, 2 pr, Standard Organic
 BS24568-74..... 9" Drum Shoes, 2 pr, Silencer Precision

DRUM COMPONENTS

Available components include backing plates, adjusters and spring sets. Brake drum hardware kits contain the springs and retainers needed to rebuild an original drum brake assembly. Adjusters are sold in pairs.



DHK670168-74..... Front Drum Hardware (2 Sets)
 DHK670267-88..... Rear Drum Hardware (2 Sets)
 DHK670367-88..... Adjusters, Front or Rear (2 Pcs)
 DBBP81L68-74..... 9" Drum Backing Plate, Left
 DBBP81R68-74..... 9" Drum Backing Plate, Right

NOVA FRONT BRAKE COMPONENTS

CALIPERS

New calipers are supplied loaded with pads, banjo bolts & copper washers. Mounting pins are provided when applicable. Black & Red powder coating finish is unaffected by brake fluid. *Rebuild & new 4 piston calipers do not include pads or hardware. Core charges may apply.



- BC01L..... 67-68 Left, 4 Piston, Stainless Sleeve, with Exch.
- BC01LC..... 67-68 Left, Core Charge
- BC01R..... 67-68 Right, 4 Piston, Stainless Sleeve, with Exch.
- BC01RC 67-68 Right, Core Charge
- BC22L..... 67-68 Left, Great 4 Piston Caliper Reproduction, All New Parts, Stainless Sleeve, No Core!
- BC22R..... 67-68 Right, Great 4 Piston Caliper Reproduction, All New Parts, Stainless Sleeve, No Core!
- BC03LN 69-74 Left, New with Pads
- BC03RN.... 69-74 Right, New with Pads
- BC4344 69-74 Red or Black Powdercoat (pr)
- BC0424 75-77 Red or Black Powdercoat (pr)
- BC0524 78-79 Red or Black Powdercoat (pr)

SPINDLES

CNC machined from forged steel. Two hard to find caliper mounting bolts are included with each pair of spindles. 2" drop installations require caliper bracket & backing plate modifications. Listings are for disc brake systems, call for drum.



- DBSP0262-67 Disc Brake Spindles with large bolts (pr)*
- DBSP0562-67 2" Drop Disc Brake Spindles with bolts (pr)*
- DBSP0168-69 Disc Brake Spindles with large bolts (pr)
- DBSP0468-74 2" Drop Disc Brake Spindles with bolts (pr)

BACKING PLATES

Often called dust shields, these plates provide some level of protection from road debris.



- DBBP0367-68 4 Piston Backing Plates (pr)
- DBBP0169-74 Single Piston Backing Plates (pr)

ROTORS

Brake rotors are shipped with bearing races installed. A Drilled-Slotted-Zinc Plated option is available on select rotors.



- BR01C.....67-68..... Front Rotor, 4 Piston, 1 Pc Design
- BR69C.....67-68..... Front Rotor, 4 Piston, 2 Pc Design
- BR02C.....69-74..... Front Rotor, 1 Pc Design
- BR03C.....75-78..... Front Rotor
- BR04C.....79..... Front Rotor

MINI KITS

Mini kits include a pair of spindles, caliper brackets, & backing plates. A great value to freshen up the front end on a restoration project, or to build out a drum to disc brake conversion.

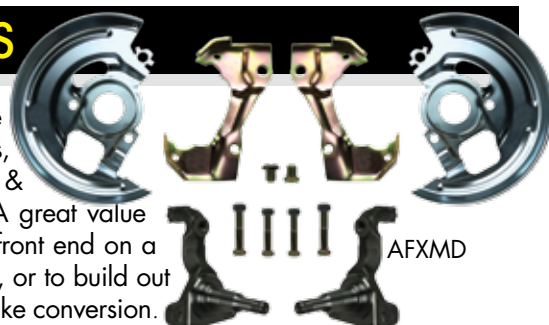

- AFXMD2.....62-67 Standard Height, Single Piston Calipers*
- AFXMD5.....62-67 2" Drop, Single Piston Calipers*
- AFXMD3.....67-68..... Standard Height, 4 Piston Piston Calipers
- AFXMD.....68-74..... Standard Height, Single Piston Calipers
- AFXMD4.....68-74..... 2" Drop, Single Piston Calipers

CALIPER BRACKETS

Yellow zinc plating provides corrosion protection on these reproduction brackets.



- CMB0667-68..... 4 Piston Caliper Brackets (pr)
- CMB0169-74..... Single Piston Caliper Brackets (pr)

DISC BRAKE PADS

Brake pads are sold in sets of four. Our base line is a midgrade standard offering. Step up to the Silencer Professional line for less dust, quieter braking, and longer pad life.



- SILENCER PROFESSIONAL**
- DP01 67-68 4 Piston Caliper Pads (2 pr)
- DP02..... 69-79 Single Piston Caliper Pads (2 pr)
- DP23..... 62-79 Rear Pads (2 pr), w/ RSD Rear Disc

NOVA MASTER CYLINDERS

MASTER CYLINDERS

All master cylinders are completely new units with no core charge. A deep cylinder pocket with a removable plug provides compatibility with manual brakes as well as power-assisted applications.



- DBMC0862-66... Drum, Single Outlet, 1" Bore
- DBMC0767-74... Power Drum, 1" Bore
- DBMC0968-69... Power Disc, 1-1/8" Bore, Deep Pocket
- DBMC1167-69... Power Disc, with Bleeders, 1-1/8" Bore, Deep, Exact Repo for '69, Delco Licensed
- DBMC1667-69... Power Disc, with Bleeders, 1-1/8" Bore, Deep, Same as DBMC11 without Casting Marks
- DBMC0175-79... Power Disc, 1-1/8" Bore, Shallow Pocket
- DBMC09C...67-69... 1-1/8" Bore, Chrome
- DBMC05C...67-69... 1" Bore, 4 Wheel Disc, Chrome
- DBMC51C...67-69... 1-1/8" Bore, Slimline Flat Top, Chrome
- DBMC56C...67-69... 1" Bore, Slimline Flat Top, Chrome

DISTRIBUTOR VACUUM LINES

Distributor vacuum lines supply intake vacuum to the distributor for timing control.

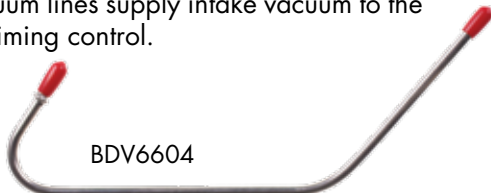

ADD "S" TO PART NUMBER FOR STAINLESS STEEL

- BDV6604 66..... 327, Carter Carb.
- XDV6601 66..... 283, 2 BBL
- FDV660566-69 Big Block with Holley Carb.
- FDV670167-69 6 Cylinder
- FDV670367-69 Small Block V-8, 4 BBL Quadrajt
- FDV670567-69 Big Block V-8, 4 BBL Quadrajt
- FDV670767-69 Small Block V-8, 2 BBL



BLOCKS & VALVES



We offer a full line of metering blocks, proportioning valves, distribution blocks and combination valves for factory drum and disc brake applications.

- RSBB01 62-68Rear Hose Brass "T" Block
- RSBB262 62-64Left Front Fender Block
- RSBB265 65-66Left Front Fender Block
- RSBB26767.....Left Front Fender Block
- RSBB362 62-65Right Front Fender Block
- RSBB36666.....Right Front Fender Block
- RSBB36767.....Right Front Fender Block
- FMB6701 67-69Hold-Off Valve
- PV68 67-69Hold-Off Valve with Bracket
- PV05 67-69Distribution Block with Bracket
- FMB700170.....Hold-Off Valve
- PV7070.....Hold-Off Valve with Bracket
- PV71 71-79Combination Valve
- PVB73 71-79Combination Valve Bracket

POWER VACUUM LINES

Power brake vacuum lines connect the intake manifold fitting to the rubber hose that runs to the power brake booster. Brackets are included as noted.



ADD "S" TO PART NUMBER FOR STAINLESS STEEL

- FBV6703 67-69Small Block
- FBV7005 67-69Big Block (Includes Bracket)
- FBV700570Big Block (Includes Bracket)
- XBV720172Small Block

INTAKE FITTINGS

Intake manifold fittings screw into your factory intake manifold to distribute vacuum to various systems.



- IMF67ZZ ... 67-69 ... 3/8" Thread with 1 3/8", Hose Connector
- IMF6705 ... 67-70 ... Big Block, 4 Speed, (Also 68-69 SB w/ 4 BBL)
- IMF6706 ... 67-70 ... Big Block, Automatic
- IMF6707 ... 67-70 ... Big Block with AC & Automatic
- IMF68RS.... 68-69 ... 3/8" Thread with 2 Ports

SLIMLINE BOOSTER MASTER COMBOS

J81315672

The slimline combos offer clean lines and plenty of power in a small package. The 8" dual is our favorite. Mounting brackets included.

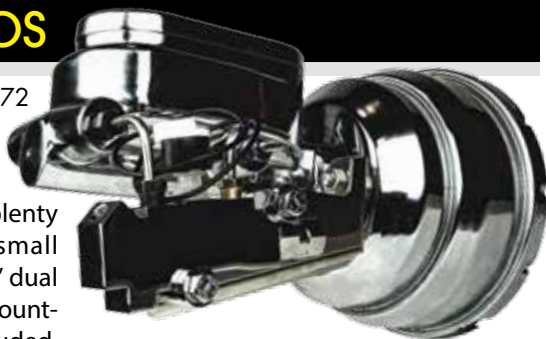

J81315672 TOP VIEW

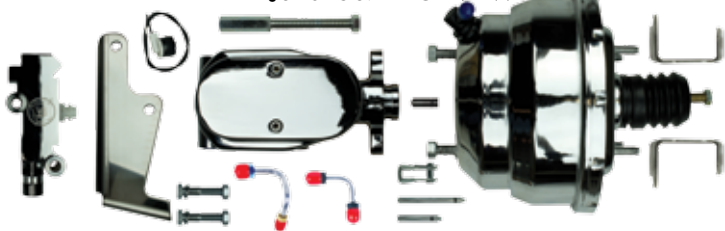

- G81310971 68-74 8" Dual, Standard Gold, Disc/Disc
- J81315171 68-74 8" Dual, Chrome, Disc/Drum
- G81310572 68-74 8" Dual, Standard Gold, Disc/Drum
- J81315672 68-74 8" Dual, Chrome, Disc/Disc
- G91020971 68-74 9" Single, Standard Gold, Disc/Drum
- G91020572 68-74 9" Single, Standard Gold, Disc/Disc

SLIMLINE BOOSTERS

Slimline boosters pack a lot of punch in a small, sleek package. Dual diaphragm versions provide 25% - 35% more assist than their single diaphragm equivalent. The 8" dual is our most popular for clearing big blocks while providing plenty of assist for two or four wheel disc brake systems. Mounting brackets included.



RPB7137



RPB7137C



RPB8131



RPB8131C

- RPB7137 68-74 7" Dual, Gold
- RPB7137C 68-74 7" Dual, Chrome
- RPB7137S 68-74 7" Dual, Stainless
- RPB8131 68-74 8" Dual, Gold
- RPB8131C 68-74 8" Dual, Chrome
- RPB8131S 68-74 8" Dual, Stainless
- RPB9102 68-74 9" Single, Gold

DELCO BOOSTER MASTER COMBOS

Factory style for 67-74 GM. Can be tight on big block cars. Available with or without Delco stamping. Mounting brackets included for 68-74 vehicles.

FDC001



FDC001 TOP VIEW

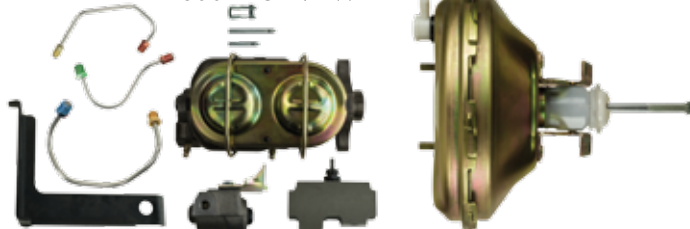

- G90201872 62-67 9" Single, Standard Gold, Disc/Disc
- G90201871 62-67 9" Single, Standard Gold, Disc/Drum
- FDC001 69 11" Single, Factory Correct Disc/Drum
- G91210971 68-74 9" Single, Standard Gold, Disc/Drum
- J91215171 68-74 9" Single, Chrome, Disc/Drum
- G91210572 68-74 9" Single, Standard Gold, Disc/Disc
- J91215672 68-74 9" Single, Chrome, Disc/Disc
- G10030971 68-74 11" Single, Standard Gold, Disc/Drum
- J10035171 68-74 11" Single, Chrome, Disc/Drum
- G10030572 68-74 11" Single, Standard Gold, Disc/Disc
- J10035672 68-74 11" Single, Chrome, Disc/Disc

DELCO BOOSTERS

Reproductions based on original factory units. GM licensed & feature a Delco Moraine stamping. This logo is available right side up and upside down. Unstamped boosters are of identical quality, but less expensive without the licensing fees. Includes mounting brackets.



RPB1001



RPB1003



RPB1003C

- RPB9020 62-67 9" Single, 3 stud
- RPB9121 68-74 9" Single, Gold
- RPB9121C 68-74 9" Single, Chrome
- RPB9016 68-74 9" Standard Gold, w/ Delco Stamping
- RPB1001 68-74 11" Single, Gold w/ Delco Stamp
- RPB1008 68-74 11" Single, Gold Upside Down Stamp
- RPB1003 68-74 11" Single, Gold
- RPB1003C 68-74 11" Single, Chrome

NOVA FUEL SYSTEM LINES

FUEL PUMP TO CARB LINES

Fuel pump to carburetor lines connect the fuel pump to the carburetor. Brass blocks and fittings are included as noted. These lines are intended to work only with factory pump, motor, intake and carburetor combinations.

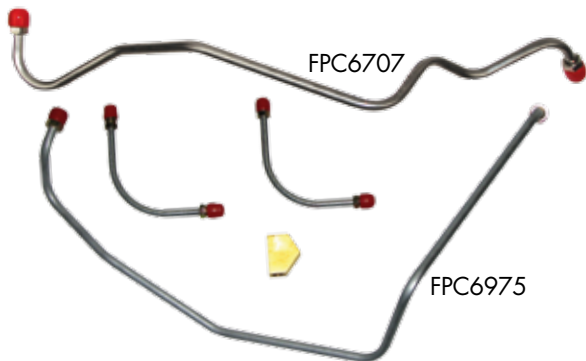

ADD "S" TO PART NUMBER FOR STAINLESS STEEL

- XPC6301 .. 63-65 ... 6 Cylinder
- BPC6202.....65 327/300 HP w/ L-74 Option 2 Pcs.
- BPC6602.. 65-67 ... 283, 2 BBL
- BPC6604.....66 327/275 HP, Carter, Enters Rear
- XPC6601 .. 66-67 ... L-79, Chrome
- FPC670267 327/210 HP, 2 BBL, Before 4-1-67
- FPC6701 .. 67-68 ... 230, 6 Cylinder
- FPC6703 .. 67-68 ... 237/210 HP, 2 BBL, After 4-1-67
- FPC6705 .. 67-68 ... 327/275 HP & 350/295 HP 4BBL, 5/16"
- FPC6707 .. 67-68 ... 327/275 HP & 350/295 HP 3/8"
- FPC6709 .. 67-68 ... 396/325-350 HP
- FPC677568 396/375 HP, Holley, 3 Lines & Block
- XPC6801 .. 68-70 ... 6 Cylinder, 1 BBL
- XPC6904.. 68-70 ... 4 Cylinder
- FPC690169 350, 2 BBL, 3/8"
- FPC690269 307 & 327, 2 BB, 5/16"
- FPC690369 396 Quadrajet 3 Pcs.
- FPC690569 350, 4 BBL, Quadrajet 3 Pcs.
- FPC697569 396/375 Holley w/ Y Block 3 Pcs.
- CPC700770 396/375 HP
- XPC7202.....72 307 2 BBL
- FPC7001 .. 70-72 ... 350/300 HP
- CPC7101 . 71-72 ... 402 BBL
- CPC7102 . 71-72 ... 350/270 HP, 4 BBL
- XPC7206.....72 250, 6 Cylinder
- XPC7208.....72 350, 4 BBL Quadrajet
- FPC750275 350 4 BBL

FUEL HOSE KITS

These small rubber hoses and clips are used to connect fuel lines to the fuel pump and sending unit.



- FHK3800.....ALL..... 3/8" x 6", 3/8" x 13", + 4 Green Clamps
- FHK1438.....ALL..... 3/8" x 6", 3/8" x 13", 1/4" x 18" + 4 Green Clamps and 4 Red Clamps

HOLLEY CARBURETOR PARTS

These components are used to accommodate various configurations of replacement & stock Holley carbs with dual fuel inlets.

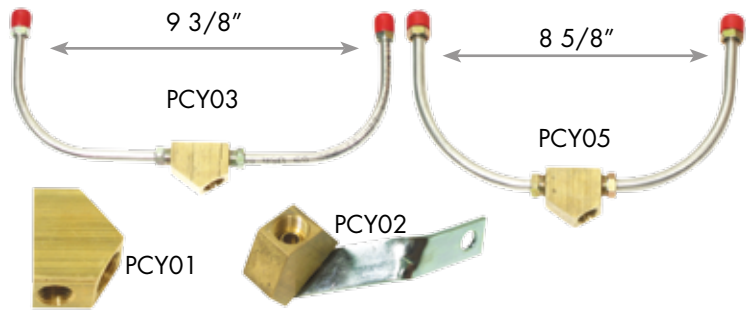

ADD "S" TO PART NUMBER FOR STAINLESS STEEL

- PCY01.....Y Block without Bracket, Brass
- PCY02.....Y Block with Bracket, Brass
- RSBB06Y Block with 3/8" Ports, Used in PCY05, Brass
- PCY03.....Original Dual Feed Holley Carb Lines, 3-Piece, 5/16" Inlets, 9-3/8" Center To Center with Block
- PCY05.....Replacement Dual Feed Holley Lines 3-Piece, 3/8" Inlets-8-5/8" Center To Center with Block
- PCY07.....Replacement Dual Feed Holley Lines 3-Piece, 3/8" Inlets-9-3/8" Center To Center with Block

FUEL TANKS

Fuel tanks are constructed of Ni-Terne steel. Hardware is not included.



- XFT620162-67 Nova
- XST620162-67 Nova - Stainless
- XFT680168-69 Nova
- XST680168-69 Nova - Stainless
- XFT7000.....70 Early 70 Nova without EEC
- XST700070 Early 70 Nova without EEC - Stainless
- XFT7309.....73-79 Nova
- XST730973-79 Nova - Stainless

MAIN FUEL LINES

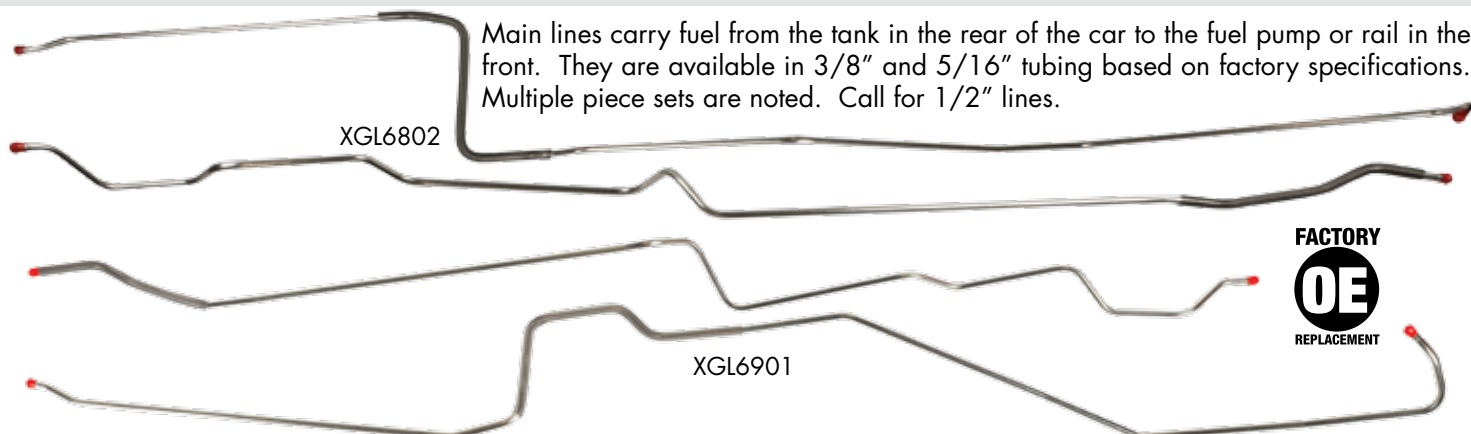

Main lines carry fuel from the tank in the rear of the car to the fuel pump or rail in the front. They are available in 3/8" and 5/16" tubing based on factory specifications. Multiple piece sets are noted. Call for 1/2" lines.

ADD "S" TO PART NUMBER FOR STAINLESS STEEL

- XGL6204.. 62-64 ... 5/16", 8 Cyl, Runs Through Fenderwell
By Battery Box
- XGL6201 .. 62-67 ... 5/16", 6 Cyl, Runs Through Tunnel
- XGL6205.. 62-67 ... 5/16" Station Wagon 2-Piece
- XGL6235.. 62-67 ... 3/8" Station Wagon 2-Piece.
- XGL6202.. 65-67 ... 5/16", 8 Cyl, Runs Through Fenderwell
By Battery Box
- XGL6203 .. 65-67 ... 3/8" Line For More Fuel, 8 Cylinder
Same As XGL6202
- XGL6601 .. 66-67 ... 3/8" Line, L-79 V-8

ADD "S" TO PART NUMBER FOR STAINLESS STEEL

- XGL6602.. 66-67 ... 3/8" Line, L-79 V-8 2-Piece.
- XGL6603 .. 66-67 ... 6 Cylinder, Wagon
- XGL680168 3/8" Main Line
- XGL680268 Front to Rear Fuel Line 2-Piece.
- XGL6901 .. 69-73 ... 3/8" Main Line 2-Piece.
- XGL6906 .. 69-73 ... 5/16", 6 Cylinder 2-Piece.
- XGL740174 3/8" Main Line 2-Piece.
- XGL750175 3/8" Main Line 2-Piece.
- XGL7601 .. 76-77 ... 3/8" Main Line 2-Piece.
- XGL780178 3/8" Main Line 2-Piece.

RETURN FUEL LINES

Return lines carry excess fuel from fuel pump or fuel filter back to the tank. Not all vehicles were equipped with a return line. They are typically made of 1/4" diameter tubing. Multiple piece sets are noted.



ADD "S" TO PART NUMBER FOR STAINLESS STEEL

- XGL690269-73 1/4" Return Line
- XGL7403 74 1/4" Return Line
- XGL750275 1/4" Return Line

VAPOR RETURN LINES

Emission control systems use these 5/16" lines to handle fuel vapors. Some vehicles use a single front to rear line. Others utilize a charcoal canister and require 3 or 4 additional small lines. Multiple piece sets are noted.

ADD "S" TO PART NUMBER FOR STAINLESS STEEL

- XEM710571-72 5/16" Vapor Set
- XEM7401 74 5/16" Vapor Line
- XEM7501 75 5/16" Vapor Set
- XEM760176-78 5/16" Vapor Set

FUEL SENDING UNITS

Sending units include floats, gaskets and snap rings where applicable. Our fuel senders are made of stainless steel and operate on the same ohm range as factory gauges.



- XSU620162-655/16" Main
- XSU620262-653/8" Main
- XSU660166-675/16" Main
- XSU660266-673/8" Main
- XSU680168-723/8" Main

TRANSMISSION VACUUM LINES

Transmission vacuum lines connect automatic transmissions to intake vacuum.



ADD "S" TO PART NUMBER FOR STAINLESS STEEL

- FTV6705 67 Turbo 400
- FTV670367-68 Turbo 350 LH Modulator
- FTV670167-69 Powerglide
- XTV680568-72 Turbo 400
- FTV690369-70 Turbo 350 RH Modulator
- XTV7401 74 Turbo 350
- XTV7501 75 Turbo 350

NOVA TRANSMISSION LINES & SUSPENSION

TRANSMISSION COOLER LINES

Transmission cooler lines are sold as pairs. Be sure to verify the type of transmission in your project before ordering. These lines are intended to work only with factory motor, transmission, and radiator combinations.

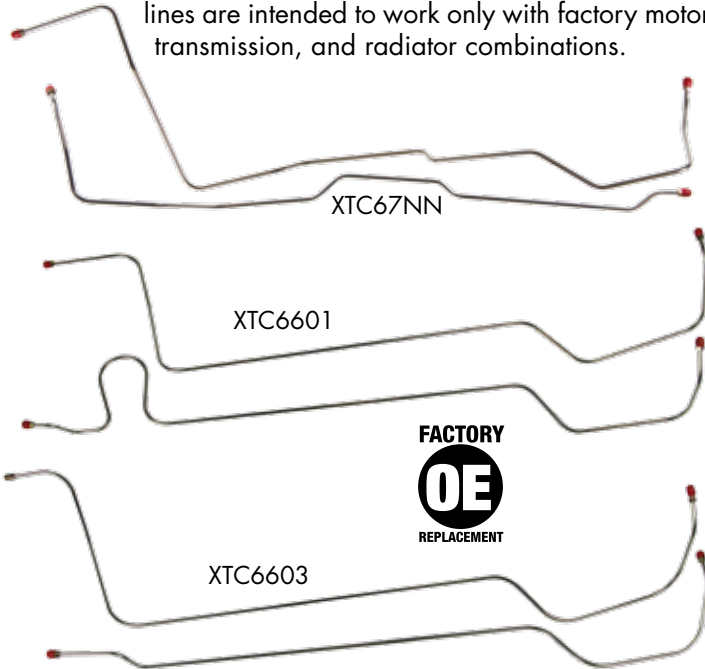

ADD "S" TO PART NUMBER FOR STAINLESS STEEL

- XTC67NN 62-67 ... 700-R4 with Large Radiator
- XTC6601 .. 66-67 ... Powerglide without Spacer at Rad.
- XTC6603 .. 66-67 ... Powerglide, 3" Spacer Rad.
- XTC6803 .. 68-72 ... Powerglide, 350, 400 with 12" Span
- XTC7001 .. 68-72 ... Powerglide, 350, 400 with 8" Span
- XTC740174 T-350, V-8
- XTC750175 T-350, V-8
- XTC7603 .. 76-78 ... T-350, V-8

POWER STEERING LINES

Power steering lines can be either pressure or return feeds in a power steering system.



- FPS6701 68 V8 Power Steering Hose
- FPH6901 69 V8 Power Steering Hose
- FPS7022 70-72 V8 Power Steering Hose
- FPS7034 73-74 V8 Power Steering Hose

AIR SHOCK LINES

These pre-bent steel tubes were used to plumb air shock together in factory applications. They are not intended for aftermarket air ride systems.

- XAS6601 66-67 with Factory Air Shocks - OE Steel
- XAS6601S 66-67 with Factory Air Shocks - Stainless

SUSPENSION PARTS

UPPER & LOWER BALL JOINTS



- XK5103 68-74 Lower
- XK5108 68-74 Upper
- XK6145 75-79 Lower
- XK5208 75-79 Upper

INNER & OUTER TIE RODS & SLEEVES



- XES681N 68-74 Inner
- XES381RL 68-74 Outer
- XES350S 68-74 Adjusting Sleeve
- XES442L 75-79 Inner, Driver Side
- XES443L 75-79 Inner, Pass Side
- XES441RL 75-79 Outer
- XES2004S ... 75-79 Adjusting Sleeve

STEERING ARMS



- DBSA02 68-74 Steering Arm, 1/2" Bolt Holes (pr)

UPPER & LOWER CONTROL ARM BUSHING KITS



- XK6076 68-74 Lower
- XK5196 68-74 Upper
- XK6109 75-79 Lower
- XK6144 75-79 Upper

SWAY BAR BUSHINGS



- XK5227 68-69 All
- XK5253 70-75 1" or Larger Bar
- XK5241 70-79 15/16" or Smaller
- XK6161 76-79 1 to 1-1/8" bar, with Tabs on Mounting Clamp

IDLER ARMS



- FIA6801 68-74 Idler Arm

SWAY BAR LINK KITS



- XK5252 68-79 All



NOVA FRONT BRAKE CONVERSIONS

**STREET
SERIES**

FRONT DISC BRAKE CONVERSION KITS

U.S.A. Made
TIMKEN Bearings

FRONT CONVERSIONS INCLUDE:

- 11" Rotors
- Forged Spindles (OE or 2" Drop)
- Timken Bearings
- New Calipers
- Caliper Brackets
- Organic Pads
- Backing Plates
- Flex Hoses & Clips
- Valve Bracket & Hardware
- Banjo Bolts & Copper Washers
- Dust Caps
- Castle Nuts & Pins
- Washers
- Grease Seals
- Spindle Gaskets
- Steering Arm Bolts
- Master Cylinder
- Combination Valve
- Pedal Rod Extension
- Brake Switch Pigtail

WORKS WITH FACTORY 14" & LARGER DISC BRAKE WHEELS

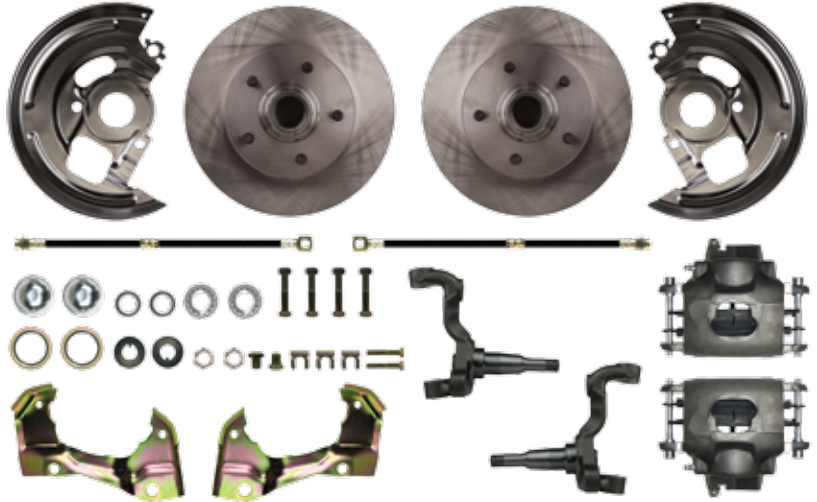

POWER PACKAGE



MANUAL PACKAGE

11" inch booster, Call for other diameters

EARLY 4 LUG NOVAS WILL NEED PART DBSA02 STEERING ARMS
Early Nova Power Kits come with correct 3-stud, 9" booster.

AT-THE-WHEEL FRONT KITS

Right Stuff disc conversions are the most complete kits in the industry at the right price. High quality components, professional packaging, and after-sale support by "hands-on" technicians create an unbeatable value. Consider one of our complete brake line packages for a carefree installation.

Packages include At-the-Wheel Disc Conversion Kit & Master Cylinder with Valve (Manual) or Master Cylinder with Booster and Valve (Power).

STOCK HEIGHT FRONT KITS

- AFXWK03C ...62-67... At-the-Wheel Disc Conversion Kit*
- AFXSD03C.....62-67... Manual Disc Conversion Package*
- AFXDC03C....62-67... Power Disc Conversion Package 9" Booster*
- AFXWK01C...68-74... At-the-Wheel Disc Conversion Kit
- AFXSD01C.....68-74... Manual Disc Conversion Package
- AFXDC01C....68-74... Power Disc Conversion Package 11" Booster

2" DROP FRONT KITS

- AFXWK03D ...62-67....2" Drop At-the-Wheel Disc Conversion Kit*
- AFXSD03D.....62-67....2" Drop Manual Disc Conversion Package*
- AFXDC03D62-67....2" Drop Power Disc Conversion Package 9"*
- AFXWK02D ...68-74....2" Drop At-the-Wheel Disc Conversion Kit
- AFXSD02D.....68-74....2" Drop Manual Disc Conversion Package
- AFXDC02D68-74....2" Drop Power Disc Conversion Package 11"

SUSPENSION KITS

Standard rubber kits meet O.E. specifications. Polyurethane kits provide better handling and a firmer ride. Poly kits include upgraded control arm bushings, sway bar bushings, and sway bar links. Pre-packaged kits offer huge savings over individual suspension parts. Most kits include the following:

- XSK630163-67... Front Rebuild Kit, 22-Piece
- FSK670168-74... Front Rebuild Kit, 22-Piece
- FSK6701U ..68-74... Front Rebuild Kit, 22-Piece (Poly)
- FSK750175..... Front Rebuild Kit, 24-Piece
- FSK7601 ...76-79... Front Rebuild Kit, 26-Pc with 15/16", 1-1/8" & 1-3/16" Sway Bar with Tabs on Mounting Clamp

- Lower Ball Joints (2)
- Upper Ball Joints (2)
- Lower Ctrl. Arm Bushings (4)
- Upper Ctrl. Arm Bushings (4)
- Inner Tie Rods (2) (Extra Value)
- Sway Bar Link Kits (2)
- Tie Rod Adj. Sleeves (2)
- Sway Bar Bushings (2)
- Outer Tie Rods (2)



FSK7501



FSK6701

**COMING
IN 2017**

FRONT DISC BRAKE CONVERSION UPGRADES

STREET SERIES

SHOW'N GO UPGRADE TRIM KITS

These At-the-Wheel Disc Conversion Kits (stock height or 2" drop) include upgraded drilled slotted rotors with zinc plating, powder coated calipers in red or black, and braided stainless hoses.



STOCK HEIGHT SHOW'N GO

AFXWK03CS ... 62-67 ... At-the-Wheel Disc Conversion Kit - Black*
 AFXWK03CZ ... 62-67 ... At-the-Wheel Disc Conversion Kit - Red*
 AFXWK01CS ... 68-74 ... At-the-Wheel Disc Conversion Kit - Black
 AFXWK01CZ ... 68-74 ... At-the-Wheel Disc Conversion Kit - Red
 AFXSD02CS 68-74 ... Manual Disc Conversion Package - Black
 AFXSD02CZ 68-74 ... Manual Disc Conversion Package - Red
 AFXDC02CS 68-74 ... 11" Power Disc Conversion Pkg - Black
 AFXDC02CZ 68-74 ... 11" Power Disc Conversion Pkg - Red

2" DROP SHOW'N GO

AFXWK03DS ... 62-67 ... 2" Drop At-the-Wheel Disc Conv Kit - Black*
 AFXWK03DZ ... 62-67 ... 2" Drop At-the-Wheel Disc Conv Kit - Red*
 AFXWK02DS ... 67-69 ... 2" Drop At-the-Wheel Disc Conv Kit - Black
 AFXWK02DZ ... 67-69 ... 2" Drop At-the-Wheel Disc Conv Kit - Red
 AFXSD02DS 68-74 ... 2" Drop Manual Disc Conv Pkg - Black
 AFXSD02DZ 68-74 ... 2" Drop Manual Disc Conv Pkg - Red
 AFXDC02DS 68-74 ... 2" Drop Power Disc Conv Pkg - Black
 AFXDC02DZ 68-74 ... 2" Drop Power Disc Conv Pkg - Red

SHOW STOPPER TRIM PACKAGES

Includes At-the-Wheel Front Disc Conversion Kit (stock height or 2" drop) with natural finish calipers. The Manual Packages get an upgraded chrome plated master cylinder and combination valve with bracket. Power Packages include an upgraded 8" dual chrome booster.

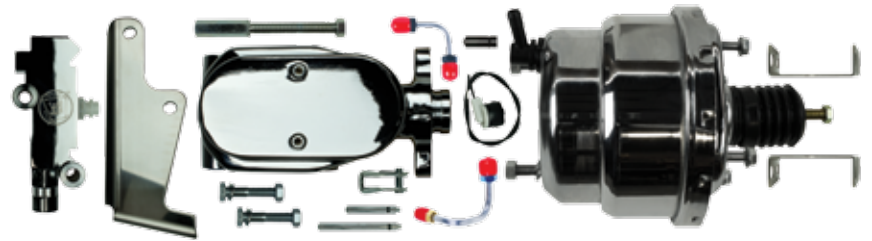

STOCK HEIGHT SHOW STOPPER

AFXSD01CX ... 68-74 Manual Disc Conversion Package
 AFXDC01CX ... 68-74 Power Disc Conversion Package 11" Booster

2" DROP SHOW STOPPER

AFXSD02DX 68-74 2" Drop Manual Disc Conversion Package
 AFXDC02DX ... 68-74 2" Drop Power Disc Conversion Package 11"

BEST OF SHOW TRIM PACKAGES

Includes At-the-Wheel Front Disc Conversion Kit (stock height or 2" drop) with black or red calipers, drilled & slotted rotors & braided stainless hoses. The Manual Packages get an upgraded chrome plated master cylinder and combination valve with bracket. Power Packages include an upgraded 8" dual chrome booster.



STOCK HEIGHT SHOW STOPPER

AFXSD02CSX 68-74 Manual Disc Conversion Package - Black
 AFXSD02CZX 68-74 Manual Disc Conversion Package - Red
 AFXDC02CSX 68-74 Power Disc Conv Pkg 11" Booster - Black
 AFXDC02CZX 68-74 Power Disc Conv Pkg 11" Booster - Red

2" DROP SHOW STOPPER

AFXSD02DSX 68-74 ... 2" Drop Manual Disc Conv Pkg - Black
 AFXSD02DZX 68-74 ... 2" Drop Manual Disc Conv Pkg - Red
 AFXDC02DSX 68-74 ... 2" Drop Power Disc Conv Pkg 11" - Black
 AFXDC02DZX ... 68-74 ... 2" Drop Power Disc Conv Pkg 11" - Red

Disc Brake Conversions require special brake lines that fit your new disc conversion setup. Right Stuff offers "No Brainer" Brake Line Kits that include all components needed from your master cylinder back to your rear wheel cylinder or calipers. They include front brake line kit, front to rear line, rear axle lines & flex hose, & clip set.

See page 74 for your application

NOVA 4-WHEEL BRAKE CONVERSIONS

**STREET
SERIES**

FOUR WHEEL DISC BRAKE CONVERSION KITS

U.S.A. Made
TIMKEN Bearings

FRONT CONVERSIONS INCLUDE:

- 11" Rotors
- Forged Spindles (OE or 2" Drop)
- Timken Bearings
- New Calipers
- Caliper Brackets
- Organic Pads
- Backing Plates
- Flex Hoses & Clips
- Valve Bracket & Hardware
- Banjo Bolts & Copper Washers
- Dust Caps
- Castle Nuts & Pins
- Washers
- Grease Seals
- Spindle Gaskets
- Steering Arm Bolts
- Master Cylinder
- Combination Valve
- Pedal Rod Extension
- Brake Switch Pigtail

REAR CONVERSIONS INCLUDE:

- 11" Rotors
- Caliper Brackets & Spacers
- Weld-On Hose Brackets
- Flex Hoses
- New Loaded Caliper
- E-Brake Cables
- Hardware
- Backing Plates

Right Stuff disc conversions are the most complete kits in the industry at the right price. High quality components, professional packaging, and after-sale support by "hands-on" technicians create an unbeatable value. Consider one of our complete brake line packages for a carefree installation. See page 69 to verify axle flange measurements for these kits.



POWER PACKAGE

MANUAL PACKAGE

WORKS WITH 15" AND LARGER WHEELS

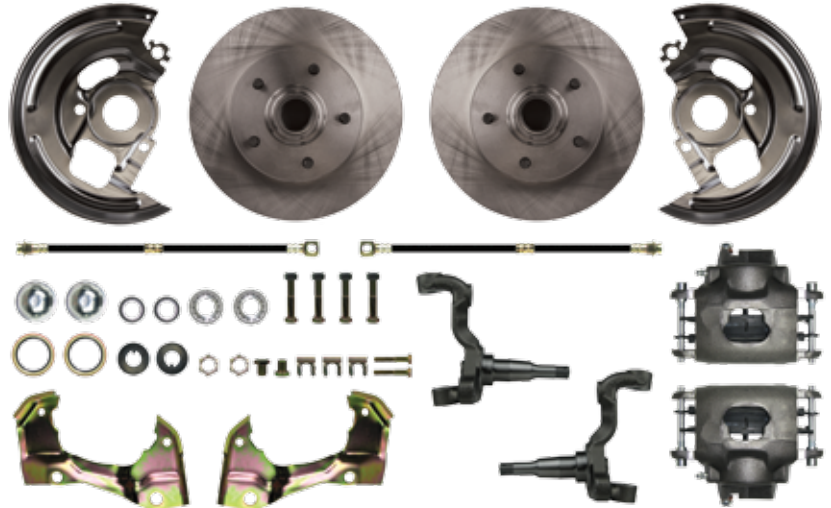

AT-THE-WHEEL FRONT KIT

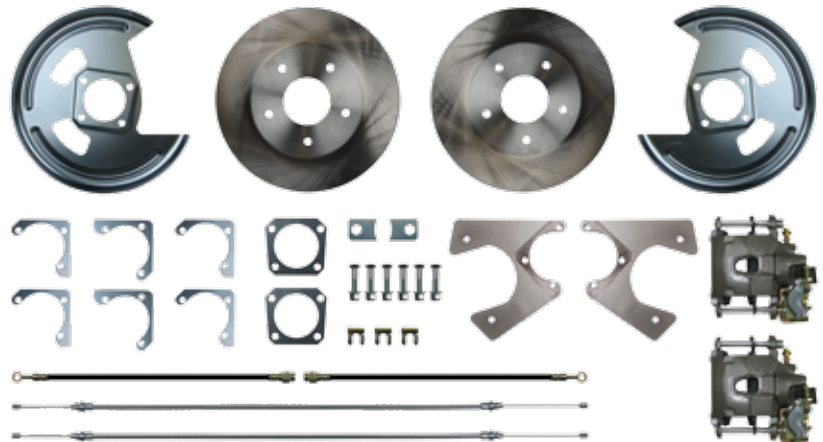

AT-THE-WHEEL REAR KIT

6-3/16" INSIDE ROTOR DIAMETER - 2.78" CENTER HOLE

Packages include At-the-Wheel Disc Conversion Kits & Master Cylinder with Valve (Manual) or Master Cylinder with Booster and Valve (Power).

EARLY 4 LUG NOVAS WILL NEED PART DBSA02 STEERING ARMS
Early Nova Power Kits come with correct 3-stud, 9" booster.

STOCK HEIGHT 4-WHEEL KITS

- AFXSD43C.....62-67 Manual Disc Brake Conv Package*
- AFXDC43C62-67 Power Disc Brake Conversion Package*
- AFXSD45C.....68-74 Manual Disc Brake Conv Package
- AFXDC45C68-74 Power Disc Brake Conversion Package

2" DROP 4-WHEEL KITS

- AFXSD43D....62-67... 2" Drop Manual Disc Brake Conv Package*
- AFXDC43D ...62-67... 2" Drop Power Disc Brake Conversion Package*
- AFXSD45D....68-74... 2" Drop Manual Disc Brake Conv Package
- AFXDC45D ...68-74... 2" Drop Power Disc Brake Conv Package



UPGRADES

The next page offers upgrades to fully customize your conversion kit.

4-WHEEL DISC BRAKE CONVERSION UPGRADES **STREET SERIES**

SHOW'N GO UPGRADE TRIM KITS

These At-the-Wheel Disc Conversion Kits (stock height or 2" drop) include upgraded drilled slotted rotors with zinc plating, powder coated calipers in red or black, and braided stainless hoses.



STOCK HEIGHT SHOW'N GO

AFXSD43CS .. 62-67 .. Manual Disc Conversion Package - Black*
 AFXSD43CZ .. 62-67 .. Manual Disc Conversion Package - Red*
 AFXDC43CS.. 62-67 .. Power Disc Conversion Pkg - 9" Booster - Black*
 AFXDC43CZ.. 62-67 .. Power Disc Conversion Pkg - 9" Booster - Red*
 AFXSD45CS .. 68-74 .. Manual Disc Conversion Pkg - Staggered - Black
 AFXSD45CZ .. 68-74 .. Manual Disc Conversion Pkg - Staggered - Red
 AFXDC45CS.. 68-74 .. Power Disc Conv Pkg - 11" Booster - Stag - Black
 AFXDC45CZ.. 68-74 .. Power Disc Conv Pkg - 11" Booster - Stag - Red

2" DROP SHOW'N GO

AFXSD43DS...62-67 ..2" Drop - Manual Disc Conversion Pkg - Black*
 AFXSD43DZ...62-67 ..2" Drop - Manual Disc Conversion Pkg - Red*
 AFXDC43DS ..62-67 ..2" Drop - Power Disc Conv Pkg - 9" Booster - Blk*
 AFXDC43DZ ..62-67 ..2" Drop - Power Disc Conv Pkg - 9" Booster - Red*
 AFXSD45DS...68-74 ..2" Drop - Manual Disc Conv Pkg - Staggered - Blk
 AFXSD45DZ...68-74 ..2" Drop - Manual Disc Conv Pkg - Staggered - Red
 AFXDC45DS ..68-74 ..2" Drop Pwr Disc Conv Pkg, 11" Booster - Stag - Blk
 AFXDC45DZ ..68-74 ..2" Drop Pwr Disc Conv Pkg, 11" Booster - Stag - Red

SHOW STOPPER TRIM PACKAGES

Includes At-the-Wheel Front Disc Conversion Kit (stock height or 2" drop) with natural finish calipers. The Manual Packages get an upgraded chrome plated master cylinder and combination valve with bracket. Power Packages include an upgraded 8" dual chrome booster.

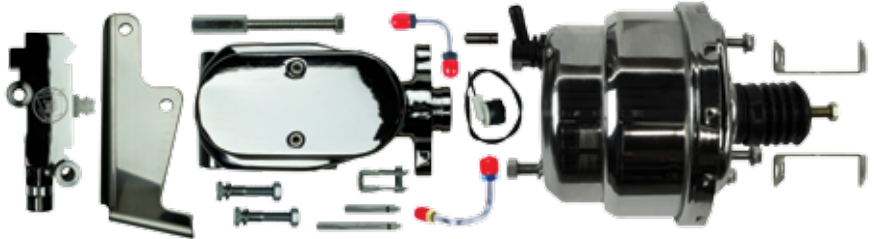

STOCK HEIGHT SHOW STOPPER

AFXSD45CX.... 68-74 Manual Disc Brake Conv Package
 AFXDC45CX ... 68-74 Power Disc Brake Conversion Package

2" DROP SHOW STOPPER

AFXSD45DX... 68-74 ... 2" Drop Manual Disc Brake Conv Pkg
 AFXDC45DX .. 68-74 ... 2" Drop Power Disc Brake Conv Package

BEST OF SHOW TRIM PACKAGES

Includes At-the-Wheel Front Disc Conversion Kit (stock height or 2" drop) with black or red calipers, drilled & slotted rotors & braided stainless hoses. The Manual Packages get an upgraded chrome plated master cylinder and combination valve with bracket. Power Packages include an upgraded 8" dual chrome booster.



STOCK HEIGHT BEST OF SHOW

AFXSD45CSX.... 68-74 ... Manual Disc Brake Conv Pkg - Black
 AFXSD45CZX.... 68-74 ... Manual Disc Brake Conv Pkg - Red
 AFXDC45CSX ... 68-74 ... Power Disc Brake Conversion Pkg - Black
 AFXDC45CZX ... 68-74 ... Power Disc Brake Conversion Pkg - Red

2" DROP BEST OF SHOW

AFXSD45DSX... 68-74 ... 2" Drop Manual Disc Brake Conv Pkg - Blk
 AFXSD45DZX... 68-74 ... 2" Drop Manual Disc Brake Conv Pkg - Red
 AFXDC45DSX .. 68-74 ... 2" Drop Power Disc Brake Conv Pkg - Black
 AFXDC45DZX .. 68-74 ... 2" Drop Power Disc Brake Conv Pkg - Red



Disc Brake Conversions require special brake lines that fit your new disc conversion setup. Right Stuff offers "No Brainer" Brake Line Kits that include all components needed from your master cylinder back to your rear wheel cylinder or calipers. They include front brake line kit, front to rear line, rear axle lines & flex hose, & clip set.

See page 74 for your application

NOVA REAR BRAKE CONVERSIONS

**STREET
SERIES**

REAR DISC BRAKE CONVERSION KITS

REAR CONVERSIONS INCLUDE:

- 11" Rotors
- Caliper Brackets & Spacers
- Weld-On Hose Brackets
- Flex Hoses
- Backing Plates (Exclusive), not for AFXRD78 or AFXRDM78
- New Loaded Caliper
- E-Brake Cables
- Hardware

Right Stuff disc conversions are the most complete kits in the industry at the right price. High quality components, professional packaging, and after-sale support by "hands-on" technicians create an unbeatable value. Consider one of our complete brake line packages for a carefree installation. **See the next page to verify axle flange measurements for these kits.**

NOTE:

FITS FACTORY
REAR ENDS
CALL FOR CUSTOM
APPLICATIONS

WORKS WITH 15" AND LARGER WHEELS

6 3/16" INSIDE ROTOR DIAMETER - 2.78" CENTER HOLE

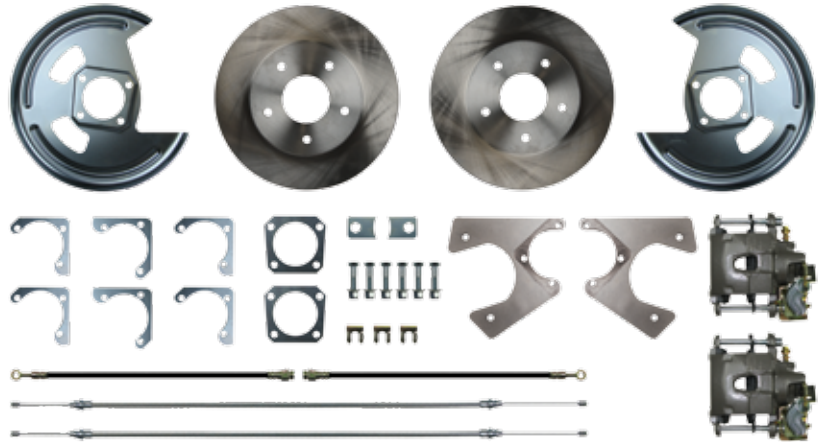

WANT MATCHING FRONT UPGRADES? SEE THE NEXT PAGE FOR OUR REAR+2 CONVERSIONS

ATTENTION Before you order, be sure to measure the axle flange on your vehicle.

REAR KITS WITH E-BRAKE

AFXRD01N ... 62-67 10 & 12 Bolt without Staggered Shocks
AFXRD01 68-79 10 & 12 Bolt without Staggered Shocks
AFXRD05 68-79 10 & 12 Bolt with Staggered Shocks

REAR KITS WITHOUT E-BRAKE

AFXRDM1 62-79 10 & 12 Bolt without Staggered Shocks
AFXRDM5 62-79 10 & 12 Bolt with Staggered Shocks

REAR DISC BRAKE CONVERSION UPGRADES

**STREET
SERIES**

SHOW'N GO UPGRADE TRIM PACKAGES

These Rear Disc Conversion Kits include upgraded drilled slotted rotors with zinc plating, powder coated calipers in red or black, and braided stainless hoses.



REAR UPGRADE WITH E-BRAKE

AFXRD01NS... 62-67.... 10 & 12 Bolt w/o Staggered Shocks - Black
AFXRD01NZ... 62-67.... 10 & 12 Bolt w/o Staggered Shocks - Red
AFXRD01S..... 68-79.... 10 & 12 Bolt w/o Staggered Shocks - Black
AFXRD01Z..... 68-79.... 10 & 12 Bolt w/o Staggered Shocks - Red
AFXRD05S..... 68-79.... 10 & 12 Bolt with Staggered Shocks - Black
AFXRD05Z..... 68-79.... 10 & 12 Bolt with Staggered Shocks - Red

REAR UPGRADE W/O E-BRAKE

AFXRDM1S.... 62-79.... 10 & 12 Bolt w/o Staggered Shocks - Black
AFXRDM1Z.... 62-79.... 10 & 12 Bolt w/o Staggered Shocks - Red
AFXRDM5S.... 62-79.... 10 & 12 Bolt with Staggered Shocks - Black
AFXRDM5Z.... 62-79.... 10 & 12 Bolt with Staggered Shocks - Red

Rear Kits do not support the use with early Nova 3.5" axle flange.

 **No Brainer
BRAKE LINE KITS**
DESIGNED FOR DISC CONVERSIONS

Disc Brake Conversions require special brake lines that fit your new disc conversion setup. Right Stuff offers "No Brainer" Brake Line Kits that include all components needed from your master cylinder back to your rear wheel cylinder or calipers. They include front brake line kit, front to rear line, rear axle lines & flex hose, & clip set.

See page 74 for your application

NOVA REAR +2 BRAKE CONVERSIONS

**STREET
SERIES**

REAR +2 DISC BRAKE CONVERSION KITS

REAR +2 CONVERSIONS INCLUDE:

- 11" Drilled-Slotted-Zinc Rear Rotors
- Black or Red Rear Powder Coated Calipers
- Braided Stainless Rear Hoses
- Caliper Brackets, Spacers, Hardware
- Weld-On Hose Brackets
- Backing Plates *TRSD Exclusive
- E-Brake Cables

+2 KITS ALSO INCLUDE

- Drilled-Slotted-Zinc Front Rotors
- Black or Red Powder Coated Front Calipers
- Braided Stainless Front Hoses

Right Stuff disc conversions are the most complete kits in the industry at the right price. High quality components, professional packaging, and after-sale support by "hands-on" technicians create an unbeatable value. Get a rear conversion and matching front upgrades with a single part number.

WORKS WITH 15" AND LARGER WHEELS

REAR DISC BRAKES + MATCHING FRONT UPGRADES
6 3/16" INSIDE ROTOR DIAMETER - 2.78" CENTER HOLE

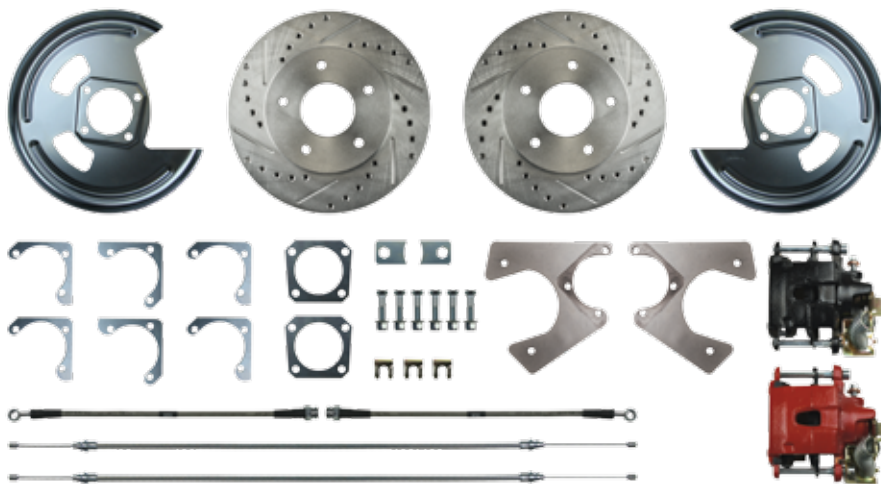

NOTE:

FITS FACTORY
REAR ENDS
CALL FOR CUSTOM
APPLICATIONS



FRONT ROTORS
DRILLED & SLOTTED



FRONT HOSES
BRAIDED STAINLESS

FRONT CALIPERS
POWDER COATED



Rear Kits do not support the use with early Nova 3.5" axle flange.

REAR +2 KITS WITH E-BRAKE

- F69RD05S 69-74Black Calipers, Drilled/Slotted
- F69RD05Z 69-74Red Calipers, Drilled/Slotted
- F70RD05S 75-77Black Calipers, Drilled/Slotted
- F70RD05Z 75-77Red Calipers, Drilled/Slotted
- F78RD05S 78Black Calipers, Drilled/Slotted
- F78RD05Z 78Red Calipers, Drilled/Slotted

REAR +2 KITS WITHOUT E-BRAKE

- F69RDM5S 69-74Black Calipers, Drilled/Slotted
- F69RDM5Z 69-74Red Calipers, Drilled/Slotted
- F70RDM5S 75-77Black Calipers, Drilled/Slotted
- F70RDM5Z 75-77Red Calipers, Drilled/Slotted
- F78RDM5S 78Black Calipers, Drilled/Slotted
- F78RDM5Z 78Red Calipers, Drilled/Slotted

AXLE FLANGE DIAGRAMS

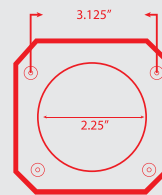
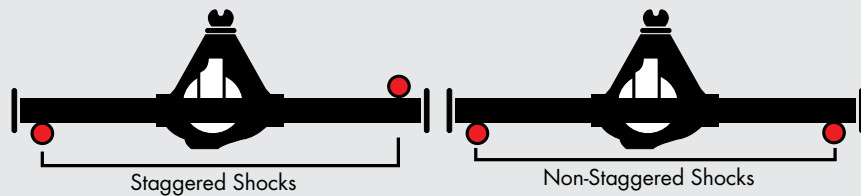

GM
AFXR01 & AFXR05
AFXR06 & AFXR07

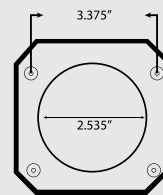

GM
FSCR01

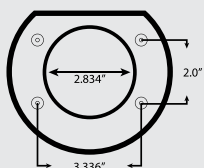

**FORD SMALL
9" or 8"**
ZDCRD02

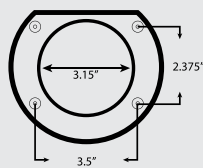

**FORD LARGE 9"
OLDSTYLE**
ZDCRD01 & ZDCRD05

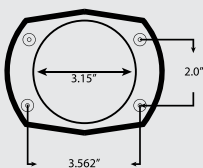

**FORD LARGE 9"
NEW TORINO STYLE**
ZDCRD01 & ZDCRD05

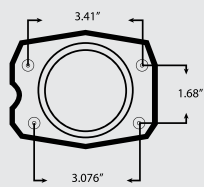

8.8" FORD
ZDCRD03

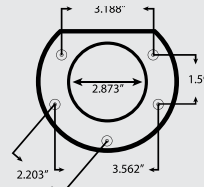

**8 3/4" and 9 3/4"
MOPAR - DANA 60**
MDCRD01

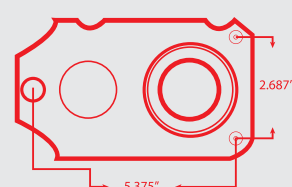

GM
AFXR078

NOVA FRONT BRAKE CONVERSIONS



BRAKE•KITS

EZ FIT BRAKE CONVERSION KITS

**HALF THE INSTALL TIME
KEEP YOUR FACTORY
14" WHEELS**

Early Nova Power Kits come with correct 3-stud, 9" booster.

Fits stock 14" wheel. Bolts to stock drum or disc brake spindles. Minimal offset for better fenderwell clearance. Proprietary rotor.

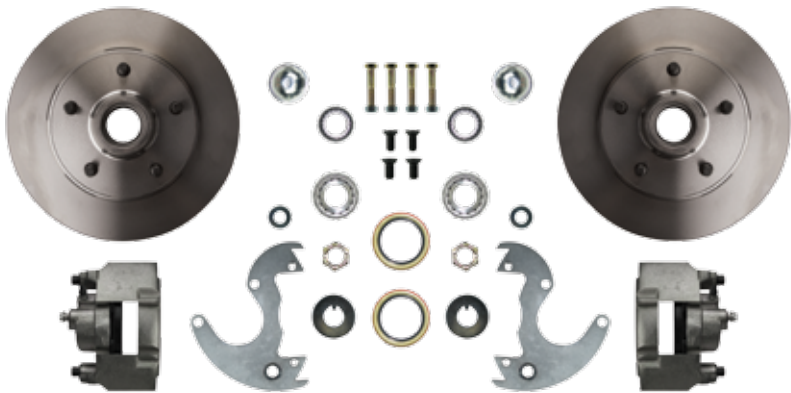

FRONT AT-THE WHEEL KITS

Bolts to your stock drum or disc brake spindles.

Available with standard stock-style rotors or upgraded drilled, slotted & zinc rotors.

FRONT 14" - STANDARD ROTORS

AFXWK1464-74..... At-the-Wheel Disc Conversion Kit
 AFXSD14N64-67..... Front Manual Disc Conversion Package
 AFXSD1468-74..... Front Manual Disc Conversion Package
 AFXDC14N.....64-67..... Front Power Disc Conversion Package
 AFXDC1468-74..... Front Power Disc Conversion Package

REAR 14" - STANDARD ROTORS

AFXRD1462-67..... Rear Kit, Non-Staggered



LOOKING FOR A DIFFERENT BOOSTER + MASTER CYLINDER IN YOUR KIT?

Simply purchase an At-The-Wheel Kit above along with any Booster + Master combo on page 59.



EZ FIT FRONT CONVERSIONS INCLUDE:

- 10" Rotors with Organic Pads
- New Calipers & Brackets
- Banjo Bolts & Copper Washers
- Dust Caps, Castle Nuts & Pins
- Brake Switch Pigtail
- Master Cylinder (Power/Manual Kits)
- Timken Bearings
- Flex Hoses & Kit
- Grease Seals
- Steering Arm Bolts
- Combination Valve
- 9" Booster (Power)

EZ FIT REAR CONVERSIONS INCLUDE:

- Fits 14" wheels
- Uses proprietary rotor
- Built in e-brake (No cables included)



Packages include At-the-Wheel Disc Conversion Kits & Master Cylinder with Valve (Manual) or Master Cylinder with Booster and Valve (Power).

POWER PACKAGE



MANUAL PACKAGE

FRONT 14" - UPGRADE ROTORS

AFXWK14A64-74..... At-the-Wheel Disc Conversion Kit
 AFXSD14NA...64-67..... Front Manual Disc Conversion Package
 AFXSD14A.....68-74..... Front Manual Disc Conversion Package
 AFXDC14NA ..64-67..... Front Power Disc Conversion Package
 AFXSD14A.....68-74..... Front Power Disc Conversion Package

REAR 14" - UPGRADE ROTORS

AFXRD14A.....62-67..... Rear Kit, Non-Staggered



**No Brainer
BRAKE LINE KITS**
DESIGNED FOR DISC CONVERSIONS

Disc Brake Conversions require special brake lines that fit your new disc conversion setup. Right Stuff offers "No Brainer" Brake Line Kits that include all components needed from your master cylinder back to your rear wheel cylinder or calipers. They include front brake line kit, front to rear line, rear axle lines & flex hose, & clip set.

See page 74 for your application

NOVA PERFORMANCE SERIES CONVERSIONS

Performance
SERIES

COMPLETE DISC BRAKE CONVERSION KITS

U.S.A. Made
TIMKEN Bearings

NEW

Right Stuff Performance Series disc conversions are the most complete kits in the industry at the right price. Designed for the performance street machine with high quality components, professional packaging, and after-sale support by "hands-on" technicians and many DIY videos at rightstuff create an unbeatable value.

Kits are available as a **Disc Brake Upgrade** that bolts to stock front disc brake spindles, or as an **At-The-Wheel Kit** that includes everything for a front disc brake conversion, and as a **Complete Conversion Kit** which includes everything in the At-The-Wheel Kit with the addition of the master cylinder, booster and prop valve (Power or Manual).

AT-THE-WHEEL CONVERSION KITS INCLUDE:

- 11" Drilled & Slotted Rotors
- Wilwood Dual Piston Calipers
- Caliper Brackets
- Backing Plates
- Timken Bearings
- Castle Nuts & Pins
- Dust Caps
- Forged Spindles
- Organic Pads
- Washers
- Grease Seals
- Spindle Gaskets
- Steering Arm Bolts
- Hardware

COMPLETE CONVERSION KITS ALSO INCLUDE

- Master Cylinder - Chrome or Standard Finish
- Flex Hoses & Clips
- Valve Bracket & Hardware
- Banjo Bolts & Copper Washers
- Combination Valve
- Brake Switch Pigtail
- Pedal Rod Extension



DISC BRAKE UPGRADE KITS INCLUDE (Kit is Designed to Bolt to Stock Disc Brake Spindles)

- Wilwood 2-Piston Aluminum Calipers
- Cross-Drilled & Slotted Zinc Plated Rotors
- Braided Stainless Hoses
- Organic Brake Pads

DISC BRAKE UPGRADE KITS

- RCP69S 69-74 Black 2-Piston Wilwood Calipers
- RCP69Z 69-74 Red 2-Piston Wilwood Calipers
- RCP70S 75-78 Black 2-Piston Wilwood Calipers
- RCP70Z 75-78 Red 2-Piston Wilwood Calipers
- RCP79S 1979 Black 2-Piston Wilwood Calipers
- RCP79Z 1979 Red 2-Piston Wilwood Calipers

WORKS WITH 15" AND LARGER WHEELS

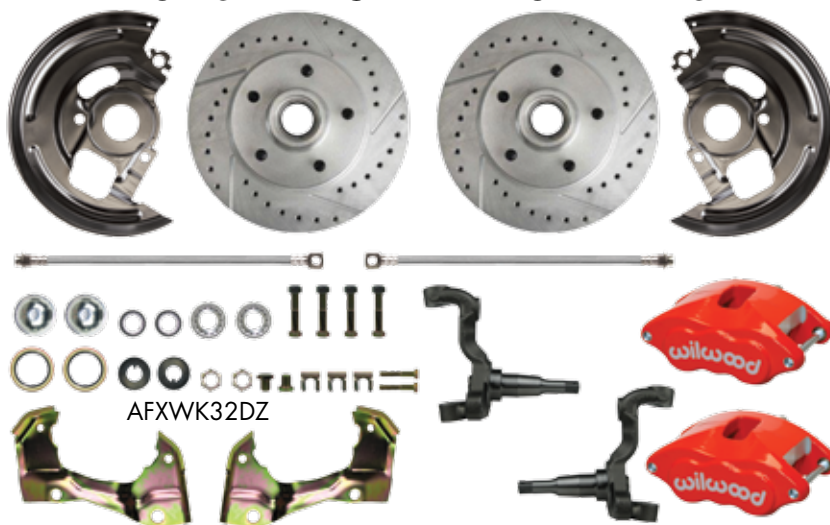

AT-THE-WHEEL KITS

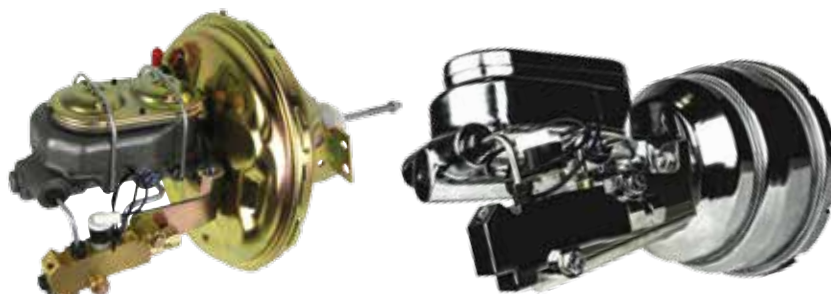

STANDARD PACKAGE

CHROME PACKAGE

Packages include At-the-Wheel Disc Conversion Kits and Chrome or Standard Finish Master Cylinder with Booster and Valve (Power).

AT-THE-WHEEL FRONT DISC KITS

- AFXWK32S 68-74 At-the-Wheel Stock Height - Black Wilwood
- AFXWK32Z 68-74 At-the-Wheel Stock Height - Red Wilwood
- AFXWK32DS ... 68-74 At-the-Wheel 2" Drop - Black Wilwood
- AFXWK32DZ ... 68-74 At-the-Wheel 2" Drop - Red Wilwood

STOCK HEIGHT FRONT KITS

- AFXDC32S 68-74 Standard Booster/Master - Black Wilwood
- AFXDC32Z 68-74 Standard Booster/Master - Red Wilwood
- AFXDC32SX 68-74 Chrome Booster/Master - Black Wilwood
- AFXDC32ZX 68-74 Chrome Booster/Master - Red Wilwood

2" DROP FRONT KITS

- AFXDC32DS ... 68-74 Standard Booster/Master - Black Wilwood
- AFXDC32DZ ... 68-74 Standard Booster/Master - Red Wilwood
- AFXDC32DSX ... 68-74 Chrome Booster/Master - Black Wilwood
- AFXDC32DZX .. 68-74 Chrome Booster/Master - Red Wilwood

NOVA SIGNATURE SERIES CONVERSIONS



DISC BRAKE CONVERSION KITS

U.S.A. Made **TIMKEN** Bearings



DESIGNED FOR 17" & LARGER WHEELS

Bold looks define the Signature Series line of brake kits. Large diameter zinc plated rotors, powder coated calipers, fully machined caliper brackets, & braided stainless brake hoses. Only premium quality components make the grade. We back every kit with industry leading technical support. Signature Series kits are amazing brakes at a great price. Add a No Brainer Brake Line Kit for a true bolt-on install.

SIGNATURE SERIES FRONT KIT

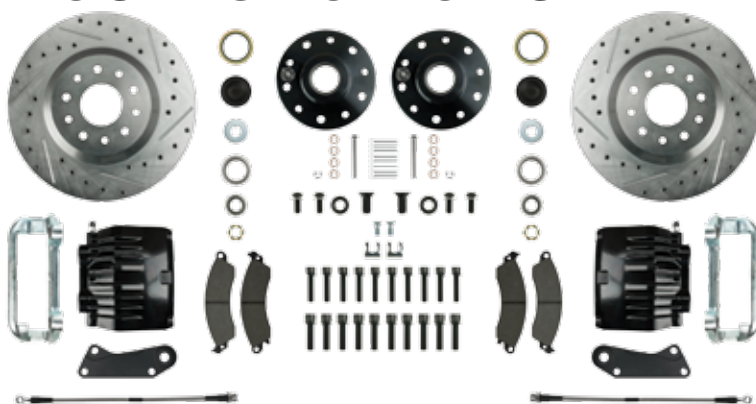

Rear Kits do not support the use with early Nova 3.5" axle flange.
* Includes spindles & requires 5-lug steering arms, part number DBSA02

STOCK HEIGHT FRONT KITS

Uses existing drum or disc brake spindles

- AFXWK33CS 62-67 At-the-Wheel Kit - Black Calipers*
- AFXWK33CZ 62-67 At-the-Wheel Kit - Red Calipers*
- AFXSD33CS..... 62-67 Manual Kit - Black Calipers*
- AFXSD33CZ..... 62-67 Manual Kit - Red Calipers*
- AFXDC33CS 62-67 Power Kit - Black Calipers*
- AFXDC33CZ 62-67 Power Kit - Red Calipers*
- AFXWK31CS 68-74 At-the-Wheel Kit - Black Calipers
- AFXWK31CZ 68-74 At-the-Wheel Kit - Red Calipers
- AFXSD31CS..... 68-74 Manual Kit - Black Calipers
- AFXSD31CZ..... 68-74 Manual Kit - Red Calipers
- AFXDC31CS 68-74 Power Kit - Black Calipers
- AFXDC31CZ 68-74 Power Kit - Red Calipers

2" DROP FRONT KITS

Includes new 2" drop spindles

- AFXWK31DS 68-74 At-the-Wheel Kit - Black Calipers
- AFXWK31DZ 68-74 At-the-Wheel Kit - Red Calipers
- AFXSD31DS..... 68-74 Manual Kit - Black Calipers
- AFXSD31DZ..... 68-74 Manual Kit - Red Calipers
- AFXDC31DS 68-74 Power Kit - Black Calipers
- AFXDC31DZ 68-74 Power Kit - Red Calipers

2" DROP 4-WHEEL KITS

Stock Height - Non-Staggered Shocks

- AFXWK51DS 68-74 At-the-Wheel Kit - Black Calipers
- AFXWK51DZ 68-74 At-the-Wheel Kit - Red Calipers
- AFXSD51DS..... 68-74 Manual Kit - Black Calipers
- AFXSD51DZ..... 68-74 Manual Kit - Red Calipers
- AFXDC51DS 68-74 Power Kit - Black Calipers
- AFXDC51DZ 68-74 Power Kit - Red Calipers

Stock Height - Staggered Shocks

- AFXWK55DS 68-74 At-the-Wheel Kit - Black Calipers
- AFXWK55DZ 68-74 At-the-Wheel Kit - Red Calipers
- AFXSD55DS..... 68-74 Manual Kit - Black Calipers
- AFXSD55DZ..... 68-74 Manual Kit - Red Calipers
- AFXDC55DS 68-74 Power Kit - Black Calipers
- AFXDC55DZ 68-74 Power Kit - Red Calipers

STOCK HEIGHT 4-WHEEL KITS

Stock Height - Non-Staggered Shocks

- AFXWK53CS 62-67 At-the-Wheel Kit - Black Calipers*
- AFXWK53CZ 62-67 At-the-Wheel Kit - Red Calipers*
- AFXSD53CS..... 62-67 Manual Kit - Black Calipers*
- AFXSD53CZ..... 62-67 Manual Kit - Red Calipers*
- AFXDC53CS 62-67 Power Kit - Black Calipers*
- AFXDC53CZ 62-67 Power Kit - Red Calipers*
- AFXWK51CS 68-74 At-the-Wheel Kit - Black Calipers
- AFXWK51CZ 68-74 At-the-Wheel Kit - Red Calipers
- AFXSD51CS..... 68-74 Manual Kit - Black Calipers
- AFXSD51CZ..... 68-74 Manual Kit - Red Calipers
- AFXDC51CS 68-74 Power Kit - Black Calipers
- AFXDC51CZ 68-74 Power Kit - Red Calipers

Stock Height - Staggered Shocks

- AFXWK55CS 68-74 At-the-Wheel Kit - Black Calipers
- AFXWK55CZ 68-74 At-the-Wheel Kit - Red Calipers
- AFXSD55CS..... 68-74 Manual Kit - Black Calipers
- AFXSD55CZ..... 68-74 Manual Kit - Red Calipers
- AFXDC55CS 68-74 Power Kit - Black Calipers
- AFXDC55CZ 68-74 Power Kit - Red Calipers

X-TRIM DISC BRAKE CONVERSION UPGRADES



X-TRIM UPGRADE 4-WHEEL KITS

Stock Height - Uses Existing Spindles Non-Staggered Shocks

- AFXSD53CSX 62-67 Stock Manual Kit - Black Calipers*
- AFXSD53CZX 62-67 Stock Manual Kit - Red Calipers*
- AFXDC53CSX 62-67 Stock Power Kit - Black Calipers*
- AFXDC53CZX 62-67 Stock Power Kit - Red Calipers*
- AFXSD51CSX 68-74 Stock Manual Kit - Black Calipers
- AFXSD51CZX 68-74 Stock Manual Kit - Red Calipers
- AFXDC51CSX 68-74 Stock Power Kit - Black Calipers
- AFXDC51CZX 68-74 Stock Power Kit - Red Calipers

Stock Height - Uses Existing Spindles Staggered Shocks

- AFXSD55CSX 68-74 Stock Manual Kit - Black Calipers
- AFXSD55CZX 68-74 Stock Manual Kit - Red Calipers
- AFXDC55CSX 68-74 Stock Power Kit - Black Calipers
- AFXDC55CZX 68-74 Stock Power Kit - Red Calipers

2" Drop - Non-Staggered Shocks

- AFXSD51DSX 68-74 2" Drop Manual Kit - Black Calipers
- AFXSD51DZX 68-74 2" Drop Manual Kit - Red Calipers
- AFXDC51DSX 68-74 2" Drop Power Kit - Black Calipers
- AFXDC51DZX 68-74 2" Drop Power Kit - Red Calipers

2" Drop - Staggered Shocks

- AFXSD55DSX 68-74 2" Drop Manual Kit - Black Calipers
- AFXSD55DZX 68-74 2" Drop Manual Kit - Red Calipers
- AFXDC55DSX 68-74 2" Drop Power Kit - Black Calipers
- AFXDC55DZX 68-74 2" Drop Power Kit - Red Calipers

Start turning heads with a show finished upper assembly. Manual kits get a chrome plated master cylinder and combination valve with bracket. Power kits also include an 8" dual chrome booster.



* Includes spindles & requires 5-lug steering arms, part number DBSA02

X-TRIM UPGRADE FRONT KITS

Stock Height - Uses Existing Drum or Disc Brake Spindles

- AFXSD33CSX 62-67 Stock Manual Kit - Black Calipers*
- AFXSD33CZX 62-67 Stock Manual Kit - Red Calipers*
- AFXDC33CSX 62-67 Stock Power Kit - Black Calipers*
- AFXDC33CZX 62-67 Stock Power Kit - Red Calipers*
- AFXSD31CSX 68-74 Stock Manual Kit - Black Calipers
- AFXSD31CZX 68-74 Stock Manual Kit - Red Calipers
- AFXDC31CSX 68-74 Stock Power Kit - Black Calipers
- AFXDC31CZX 68-74 Stock Power Kit - Red Calipers

2" Drop - Includes New 2" Drop Spindles

- AFXSD31DSX 68-74 2" Drop Manual Kit - Black Calipers
- AFXSD31DZX 68-74 2" Drop Manual Kit - Red Calipers
- AFXDC31DSX 68-74 2" Drop Power Kit - Black Calipers
- AFXDC31DZX 68-74 2" Drop Power Kit - Red Calipers



REAR DISC BRAKE CONVERSION KITS

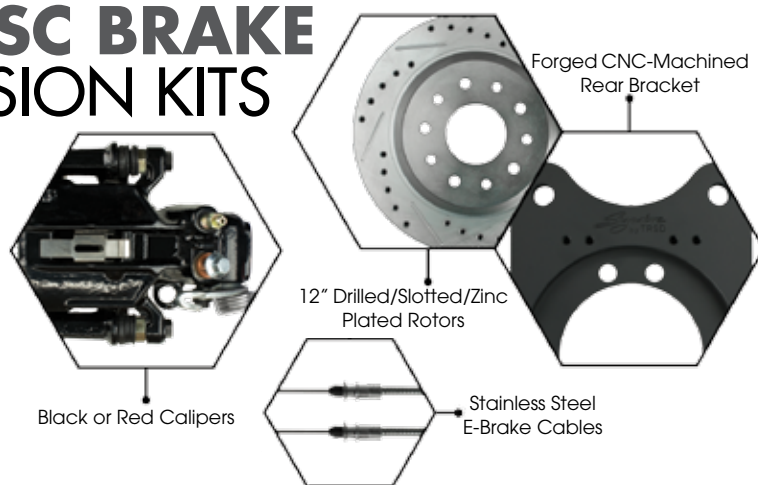
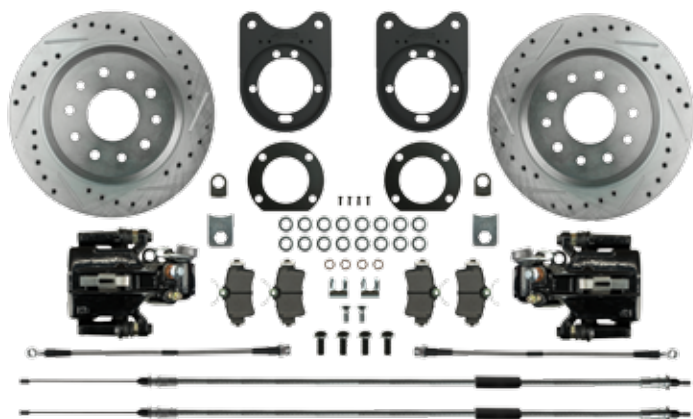

(Kit fits axles with 3 1/8 inch flange only)

REAR DISC CONVERSION KITS

- AFXRD33S 62-67 10/12-Bolt Rear Big Brake - Black
- AFXRD33Z 62-67 10/12-Bolt Rear Big Brake - Red
- AFXRD31S 68-79 10/12-Bolt Non-Staggered Shocks - Black
- AFXRD31Z 68-79 10/12-Bolt Non-Staggered Shocks - Red
- AFXRD35S 68-79 10/12-Bolt Staggered Shocks - Black
- AFXRD35Z 68-79 10/12-Bolt Staggered Shocks - Red



No Brainer BRAKE LINE KITS

DESIGNED FOR DISC CONVERSIONS

- Front Brake Line Kit • Front to Rear Line • Rear Axle Lines
- Rear Flex Hose • Clip Set



No Brainer BRAKE LINE KITS

DESIGNED FOR DISC CONVERSIONS

When you add disc brakes to your car you are using a new valve that has different size ports pointing in different directions. Even if your lines are brand new or great originals, you are going to have issues trying to use them. Our No Brainer Brake Line Kit fixes all these issues from your master cylinder all the way back to your rear wheel cylinders or rear calipers. We give you all the lines to complete the installation. We also include the rear flex hose and a full clip set to install your lines. Extremely discounted prices and great instructions make this kit a No Brainer.

SIMPLIFY YOUR DISC BRAKE CONVERSION INSTALLATION WITH ALL OF THE BRAKE LINES YOU WILL NEED.

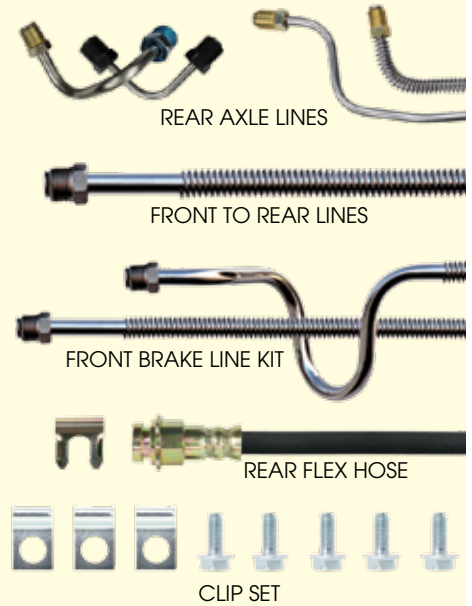

MANUAL - NO VACUUM BOOSTER

FRONT DISC/REAR DRUM LINES

- XOM62H2..... 62-65OE Steel Brake Line Kit
- XSM62H2..... 62-65Stainless Steel Brake Line Kit
- XOM66H2.....1966.....OE Steel Brake Line Kit
- XSM66H2.....1966.....Stainless Steel Brake Line Kit
- XOM67H2.....1967.....OE Steel Brake Line Kit
- XSM67H2.....1967.....Stainless Steel Brake Line Kit
- XOM68H2.....1968.....OE Steel Brake Line Kit
- XSM68H2.....1968.....Stainless Steel Brake Line Kit
- XOM69H2..... 69-74OE Steel Brake Line Kit
- XSM69H2..... 69-74Stainless Steel Brake Line Kit

POWER - WITH VACUUM BOOSTER

FRONT DISC/REAR DRUM LINES

- XOP62H2..... 62-65OE Steel Brake Line Kit
- XSP62H2..... 62-65Stainless Steel Brake Line Kit
- XOP66H2.....1966.....OE Steel Brake Line Kit
- XSP66H2.....1966.....Stainless Steel Brake Line Kit
- XOP67H2.....1967.....OE Steel Brake Line Kit
- XSP67H2.....1967.....Stainless Steel Brake Line Kit
- XOP68H2.....1968.....OE Steel Brake Line Kit
- XSP68H2.....1968.....Stainless Steel Brake Line Kit
- XOP69H2..... 69-74OE Steel Brake Line Kit
- XSP69H2..... 69-74Stainless Steel Brake Line Kit

4-WHEEL DISC LINES

- XOM62H4..... 62-65OE Steel Brake Line Kit
- XSM62H4..... 62-65Stainless Steel Brake Line Kit
- XOM66H4.....1966.....OE Steel Brake Line Kit
- XSM66H4.....1966.....Stainless Steel Brake Line Kit
- XOM67H4.....1967.....OE Steel Brake Line Kit
- XSM67H4.....1967.....Stainless Steel Brake Line Kit
- XOM68H4.....1968.....OE Steel Brake Line Kit
- XSM68H4.....1968.....Stainless Steel Brake Line Kit
- XOM69H4..... 69-74OE Steel Brake Line Kit
- XSM69H4..... 69-74Stainless Steel Brake Line Kit

4-WHEEL DISC LINES

- XOP62H4..... 62-65OE Steel Brake Line Kit
- XSP62H4..... 62-65Stainless Steel Brake Line Kit
- XOP66H4.....1966.....OE Steel Brake Line Kit
- XSP66H4.....1966.....Stainless Steel Brake Line Kit
- XOP67H4.....1967.....OE Steel Brake Line Kit
- XSP67H4.....1967.....Stainless Steel Brake Line Kit
- XOP68H4.....1968.....OE Steel Brake Line Kit
- XSP68H4.....1968.....Stainless Steel Brake Line Kit
- XOP69H4..... 69-74OE Steel Brake Line Kit
- XSP69H4..... 69-74Stainless Steel Brake Line Kit

PROPORTIONING VALVES

DOES YOUR VALVE LOOK LIKE THIS?

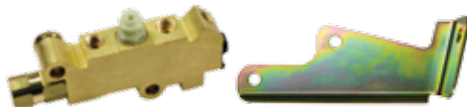

When upgrading to disc brakes or keeping them stock, make sure your proportioning valve is designed for the brake system that is specific to your vehicle.



- PVK71 Disc/Drum Proportioning Valve - Brass Finish
- PVK72 Disc/Disc Proportioning Valve - Brass Finish
- PVK71C..... Disc/Drum Proportioning Valve - Chrome Finish
- PVK72C..... Disc/Disc Proportioning Valve - Chrome Finish

FRONT TO REAR BRAKE LINES

Front to rear brake lines go from the distribution, combination or metering valve along the length of the vehicle to the rear flex hose. Lines are manufactured in 1 or 2 pieces based on factory specifications.

MIN7701



ADD "S" TO PART NUMBER FOR STAINLESS STEEL

- MIN700170Front to Rear, 2-Piece.
- MIN710171-72Front to Rear
- MIN770173-77Front to Rear
- MIN880180-88Front to Rear

FRONT BRAKE LINE KITS

Front brake line kits consist of all brake lines under the hood. This includes the master cylinder to the distribution, combination or metering valve. The left and right front lines that run to the front flex hoses are also included. Call for individual component pricing. These line kits are for vehicles with factory brake systems.

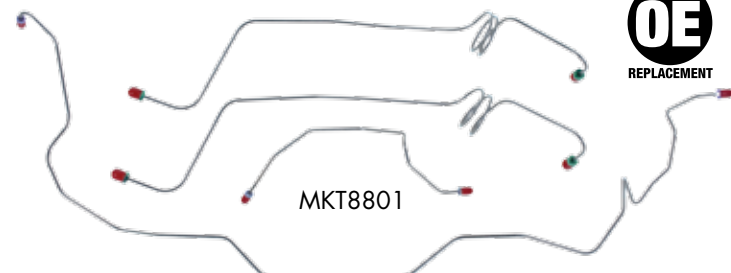

MKT8801

ADD "S" TO PART NUMBER FOR STAINLESS STEEL

- MKT7001 70Power Disc
- MKT710171-72.....Power Disc
- MKT770173-77.....Power Disc
- MKT8801 80-88.....Power Disc

REAR AXLE BRAKE LINES

Rear axle brake lines include a pair of lines that run across the rear axle housing. These lines connect the wheel cylinders or calipers to the flex hose in the middle of the rear end. They work with original housings that use factory brakes. Modifications such as rear disc brakes or narrowed rear ends will likely require special lines. Call for more information.



CRA6803

CRA8001

ADD "S" TO PART NUMBER FOR STAINLESS STEEL

- CRA6803 70-72 All Cars
- MRA7701 73-77 All Cars
- MRA740274 All Cars
- CRA8001 81-88 All Cars

FRONT FLEX HOSES

Front flex hoses provide a flexible connection from the body or frame to the front calipers or wheel cylinders as they move during suspension travel. Choose between O.E. rubber or braided stainless steel. All of our hoses are D.O.T. approved. Hoses are priced individually.

FH20



ADD "S" TO PART NUMBER FOR STAINLESS STEEL

- FH20 70-73Front Disc
- FH162 74-75Front- All Cars
- FH16376Front-All Cars
- FH16477Front-All Cars
- FH79 79-88Front-All Cars

REAR FLEX HOSES

Rear flex hoses carry brake fluid between the body of the car and the rear. Hoses are available in O.E. rubber and braided stainless steel. 'T' blocks are attached whenever factory correct. All of our hoses are D.O.T. approved. Prices are per hose.

FH06



ADD "S" TO PART NUMBER FOR STAINLESS STEEL

- FH06 70-72 Rear-All Cars
- FH1873 Rear-All Cars
- FH169 74-75 Rear-All Cars
- FH113 76-77 Rear-All Cars
- FH166 78-88 Rear-All Cars

FLEX HOSE BRACKETS

These brackets and hardware are used to secure flex hoses to various parts of the vehicle. Front brackets are sold in pairs.



FHC01

RSBK70

- RSBK7070-72.....Front Hose Brackets (pr)
- FHC01 AllCorrect Gold Cadmium Plated C Clips

SILICON BRAKE FLUID

- SBF001 Brake Fluid

MONTE CARLO CALIPERS & SPINDLES

CALIPERS

New calipers are supplied loaded with pads*, banjo bolts and copper washers. No core charge applies. Mounting pins are provided when applicable. Black and Red powder coating options provide a smooth, finished look that is unaffected by leaking brake fluid. *Rebuild and new 4 piston calipers do not include pads or hardware. Core charges apply as noted.

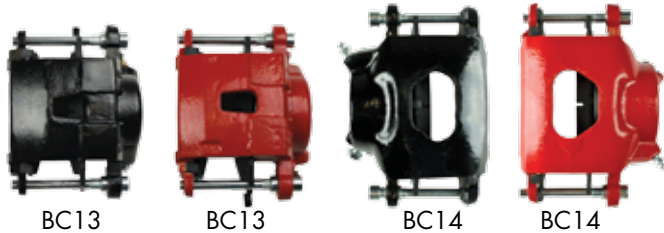

- BC14N.....70-72..... Left Front, New with pads
- BC15N.....70-72..... Right Front, New with pads
- BC141570-72..... Red, Black, or Powdercoat (pr)
- BC080973-77..... Red or Black Powdercoat (pr)
- BC12N.....78-88..... Left Front, New with pads
- BC13N.....78-88..... Right Front, New with pads
- BC121378-88..... Red or Black Powdercoat (pr)

ROTORS & DRUMS

Brake rotors & drums are sold individually.



- BR02C..... 70-72Front Rotor
- BD01 70-72Rear Drum
- BR03C..... 73-77Front Rotor
- BR07C.....78Front Rotor
- BR22C..... 79-81Front Rotor
- BR08C..... 82-88Front Rotor

DISC BRAKE PADS

Brake pads are sold in sets of four. Our base line is a midgrade standard offering. Step up to the Silencer Professional line for less dust, quieter braking, and longer pad life.



SILENCER PROFESSIONAL

- DP02..... 70-77Single Piston Front Pads (2 pr)
- DP23..... 78-88Single Piston Front Pads (2 pr)
- DP23..... 70-87Rear Pads (2 pr), w/ RSD Rear Disc

SPINDLES

Our spindles are forged steel with precision CNC machining. Two hard to find caliper mounting bolts are included with each pair of spindles. 2" drop installations require caliper bracket and backing plate modifications. All listings are for disc brake applications. Call for drum brake applications.



- DBSP0170-72..... Disc Brake Spindles with large bolts (pr)
- DBSP0470-72..... 2" Drop Disc Brake Spindles with bolts (pr)

CALIPER BRACKETS

Yellow zinc plating provides corrosion protection on these reproduction brackets.



- CMB0170-72..... Single Piston Caliper Brackets (pr)

BACKING PLATES

Often called dust shields, these plates provide some level of protection from road debris.

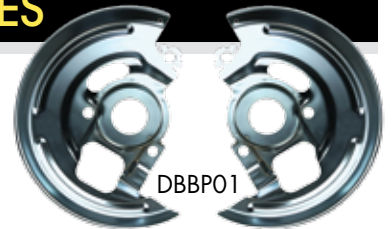

- DBBP0170-72..... Single Piston Backing Plates (pr)

MINI KITS

Mini kits include a pair of spindles, caliper brackets, & backing plates. Kits are a great value to freshen up the front end on a restoration project, or to build out a drum to disc brake conversion.

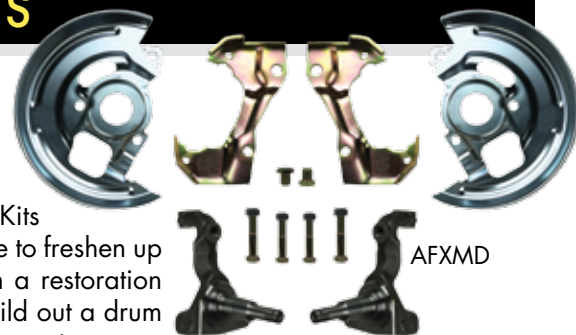

- AFXMD.....70-72..... Standard Height, Single Piston Calipers
- AFXMD4....70-72..... 2" Drop, Single Piston Calipers

WHEEL CYLINDERS

Wheel cylinders are priced individually. Hardware is not included.



- WC03.....70-75..... Rear

MONTE CARLO E-BRAKE & MASTER CYLINDERS

E-BRAKE CABLES

Parking brake cable sets contain all the individual cables and hardware needed to restore the system. Front, rear, and intermediate cables are also sold individually. While supplies last. Sold in O.E. mild steel and stainless steel. Cable kits and rear cables listed below are for rear drum vehicles. Call if you have a rear disc conversion.



ADD "S" TO PART NUMBER FOR STAINLESS STEEL

• E-Brake Cable Kits

RSBCM0170-72..... Excluding Turbo 400
 RSBCM0270-72..... Turbo 400
 RSBCM0373-77..... Excluding Turbo 400
 Call Us!73-77..... Turbo 400*
 RSCBM0678-88..... Monte Carlo, Manual
 RSBCM0681-88..... Monte Carlo, Automatic

• Front Brake Cables

EBC701470-72..... Monte Carlo, Turbo 400
 EBC703270-72..... Monte Carlo, Excl. Turbo 400
 EBC701573-77..... Monte Carlo, Excl. Turbo 400

• Intermediate Brake Cables

EBC801570-72..... Monte Carlo, Turbo 400
 EBC802870-72..... Monte Carlo, Excl. Turbo 400
 EBC801673-77..... Monte Carlo, Excl. Turbo 400

• E-Brake Hardware

EBH3001 70-77 Olive Green Center Pull
 EBH1001 70-77 Jam Nut
 RSCLP23 70-88 Parking Brake Clip - Black
 EBH3002 70-72 Center to Rear Silver Connector
 EBH2005 70-72 Silver Rear Hook, Excl. T-400
 EBH2006 70-77 Front Hook, Excl. T-400
 EBH2014 70-72 7-1/4 Hook, T-400
 EBH2011 73-77 10-1/4 J Hook, Excl. T-400
 EBH3002 78-88 Center to Rear Silver Connector
 EBH1005 78-88 5/16" Lock Nut
 EBH1006 78-88 5/16" x 3/4" Long Bolt

• Rear Brake Cables

EBC901470-72..... Monte Carlo, Turbo 400
 EBC903470-72..... Monte Carlo, Excl. Turbo 400
 EBC901573-77..... Monte, Excl. Turbo 400

MASTER CYLINDERS

All master cylinders are completely new units with no core charge. A deep cylinder pocket with a removable plug provides compatibility with manual brakes as well as power-assisted applications.



DBMC1970..... Master Cylinder, Power Brakes with Bleeders
 DBMC0171-77... Master Cylinder, Power Brakes, 1-1/8" Bore
 DBMC09C ...70-77... 1-1/8" Bore, Chrome
 DBMC05C ...70-77... 1" Bore, 4 Wheel Disc, Chrome
 DBMC51C ...70-77... 1-1/8" Bore, Slimline Flat Top, Chrome
 DBMC56C ...70-77... 1" Bore, Slimline Flat Top, Chrome

VALVES & BLOCKS

We offer a full line of metering blocks, proportioning valves, distribution blocks and combination valves for factory drum and disc brake applications.



PV7070..... Hold-Off Valve (with Bracket)
 PV7171-77..... Disc/Drum Combination Valve
 PV71C71-77..... Disc/Drum Combination Valve, Chrome
 PV7271-77..... Disc/Disc Combination Valve
 PV72C71-77..... Disc/Disc Combination Valve, Chrome
 PVB7871-77..... Combination Valve Bracket

LINES NOT LISTED?

If you need a line that is not listed in our catalog and you have a good original, you may qualify for free lines. Call us today for details.



MONTE CARLO BRAKE BOOSTERS

SLIMLINE BOOSTER MASTER COMBOS

J81315672

The slimline combos offer clean lines and plenty of power in a small package. The 8" dual is our favorite. Mounting brackets included.

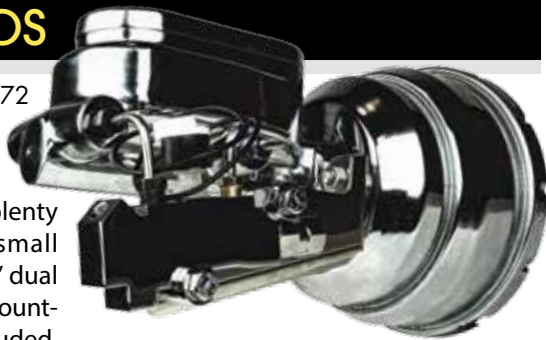

J81315672 TOP VIEW

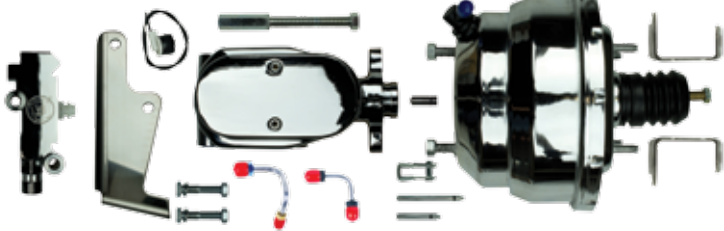

- G8131097170-72..... Gold 8" Dual, Disc/Drum
- J8131517170-72..... Chrome 8" Dual Disc/Drum
- G8131057270-72..... Gold 8" Dual, Disc/Disc
- J8131567270-72..... Chrome 8" Dual Disc/Disc
- G9102097170-72..... Gold 9" Single, Disc/Drum
- G9102057270-72..... Gold 9" Single, Disc/Disc

SLIMLINE BOOSTERS

Slimline boosters pack a lot of punch in a small, sleek package. Dual diaphragm versions provide 25% - 35% more assist than their single diaphragm equivalent. The 8" dual is our most popular for clearing big blocks while providing plenty of assist for two or four wheel disc brake systems. Mounting brackets included.



RPB7137



RPB7137C



RPB8131



RPB8131C

- RPB713770-72..... 7" Dual, Standard Gold
- RPB7137C70-72..... 7" Dual, Chrome Plated
- RPB7137S70-72..... 7" Dual, Polished Stainless
- RPB813170-72..... 8" Dual, Standard Gold
- RPB8131C70-72..... 8" Dual, Chrome Plated
- RPB8131S70-72..... 8" Dual, Polished Stainless
- RPB910270-72..... 9" Single, Standard Gold

DELCO BOOSTER MASTER COMBOS

Factory style for 67-81 GM. Can be tight on big block cars. Available with or without Delco stamping. Mounting brackets included.



G10030971

Factory style for 67-72 GM can be tight on big block cars. The 11" is our most popular booster. Available with or without Delco stamping. Mounting brackets included.

G10030971 TOP VIEW

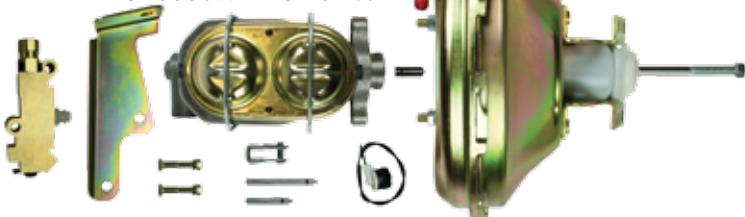

- G9121097170-72..... Gold 9" Single Disc/Drum
- J9121517170-72..... Chrome 9" Single, Disc/Drum
- G9121057270-72..... Gold 9" Single Disc/Disc
- J9121567270-72..... Chrome 9" Single, Disc/Disc
- G1003097170-72..... Gold 11" Single Disc/Drum
- J1003517170-72..... Chrome 11" Single, Disc/Drum
- G1003057270-72..... Gold 11" Single Disc/Disc
- J1003567270-72..... Chrome 11" Single, Disc/Disc

DELCO BOOSTERS

Reproductions based on original factory units. GM licensed & feature a Delco Moraine stamping. This logo is available right side up and upside down. Unstamped boosters are of identical quality, but less expensive without the licensing fees. Includes mounting brackets.



RPB1001



RPB1003



RPB1003C

- RPB912170-72..... 9" Single, Gold
- RPB901670-72..... 9" Standard Gold, with Delco Stamping
- RPB9121C70-72..... 9" Single, Chrome
- RPB100170-72..... 11" Single, Gold with Delco Stamp
- RPB100870-72..... 11" Single, Gold Upside Down Stamp
- RPB100370-72..... 11" Single, Gold
- RPB1003C70-72..... 11" Single, Chrome

MAIN FUEL LINES

Main lines carry fuel from the tank in the rear of the car to the fuel pump or rail in the front. They are available in 3/8" and 5/16" tubing based on factory specifications. Multiple piece sets are noted. Call for 1/2" lines.

ADD "S" TO PART NUMBER FOR STAINLESS STEEL

MGL7001...70-72 ...Main Fuel Line
 MGL7701...73-77 ...3/8" Main Fuel Line
 MGL8801...80-88 ...3/8" Main Fuel Line Carbureted
 MGL8803...81-88 ...3/8" Main, Fuel Injected, 2-Pieces.

MGL8801



VAPOR RETURN LINES

Emission control systems use these 5/16" lines to handle fuel vapors. Some vehicles use a single front to rear line. Others utilize a charcoal canister and require 3 or 4 additional small lines. Multiple piece sets are noted.

ADD "S" TO PART NUMBER FOR STAINLESS STEEL

MEM7001.....70 Hardtop
 MEM7101..71-72.. Hardtop
 MEM8804..80-88.. Carbureted/Fuel Injected 5/16

MEM7101



TRANSMISSION COOLER LINES

Transmission cooler lines are sold as pairs. Be sure to verify the type of transmission in your project before ordering. These lines are intended to work only with factory motor, transmission, and radiator combinations.

FUEL PUMP TO CARB LINES

Fuel pump to carburetor lines connect the fuel pump to the carburetor. Brass blocks and fittings are included as noted. These lines are intended to work only with factory pump, motor, intake and carburetor combinations.

MTC7005



ADD "S" TO PART NUMBER FOR STAINLESS STEEL

MTC7001 70-72 Powerglide
 MTC7003..... 70-72 T-350
 MTC7005..... 70-72 T-400
 MTV720172 TH350 Trans. Vacuum Line
 MTC7303.....73 T-350
 MTC7403..... 74-77 T-350
 MTC8501 81-88 700-R4, Metric

FPC7001

FPC7801



ADD "S" TO PART NUMBER FOR STAINLESS STEEL

CPC7006 70 LS-6 Short Pump With Block... 3 Pcs.
 CPC7007 70 LS-6 Long Pump With Block... 3 Pcs.
 FPC7005 70 LS-5 & L34 with Long Pump
 MPC7001 70 454, 4 BBL
 FPC700170-72 ... 350/300 HP
 CPC7101 ...71-72 ... 402, 4 BBL
 CPC7102 ...71-72 ... 350, 4 BBL, 270 HP
 CPC7301 72 350, V-8, 2 BBL
 MPC7201..... 72 350 with Quadrajel
 MPC7701...73-77 ... 350 with Quadrajel
 FPC7802 78 350, 4 BBL
 FPC780178-80 ... V-8, 2 BBL
 FPC800179-81 ... 350, Quadrajel
 MPC8701..... 87 305 V-8

FUEL TANK VENT LINES

Fuel tank vent lines allow the air inside the fuel tank to escape as it is filled with fuel. They also prevent pressure from building up due to temperature changes.

ADD "S" TO PART NUMBER FOR STAINLESS STEEL O.M.

MFV800188 3/8, 5/16, 1/4 Fuel Vent, V8 4 BBL, V8, 4 BBL, LS
 Only, Single Exhaust, 3-Piece

MONTE CARLO SUSPENSION COMPONENTS

SUSPENSION PARTS

UPPER & LOWER BALL JOINTS

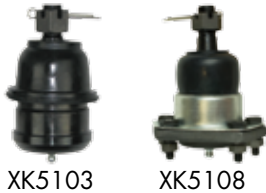

XK5103 XK5108

XK5103.....70-72..... Lower
 XK5108.....70-72..... Upper
 XK6145.....73-88..... Lower
 XK5208.....73-88..... Upper

INNER & OUTER TIE RODS & SLEEVES

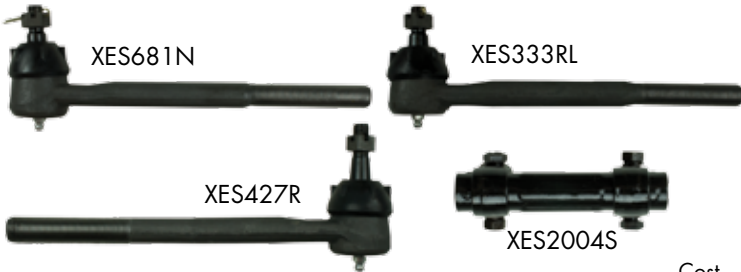

XES681N 70 Inner
 XES333RL 70 Outer
 XES2032S 70 Adjusting Sleeve
 XES2004S 71-77 Adjusting Sleeve
 XES427R 73-77 Outer

Cost

SWAY BAR LINK KITS



XK5252 XK5110

XK5252.....73-77..... All
 XK5110.....70-72..... All

Cost

FUEL HOSE KITS

These small rubber hoses and clips are used to connect fuel lines to the fuel pump and sending unit.



FHK3800

Cost

FHK3800.....ALL..... 3/8" x 6", 3/8" x 13", + 4 Green Clamps
 FHK1438.....ALL..... 3/8" x 6", 3/8" x 13", 1/4" x 18" + 4 Green Clamps and 4 Red Clamps



SWAY BAR BUSHINGS



XK6161

XK5241.....70-75..... All
 XK5241.....76-80..... with Tabs on Mounting Clamp
 XK5253.....70-75..... 1" or Larger Bar
 XK6161.....76-80..... 1" to 1-1/8" Bar with Tabs on Clamp

IDLER ARMS



CIA7701

Cost

CIA770176-77..... Idler Arm with Various Ratio Hydraulic Steering
 CIA780178-88..... Idler Arm (Excludes Handling Package for 78-79)

STEERING ARMS

DBSA0170-72... Steering Arm, 1/2" Bolt Holes (pr)

UPPER & LOWER CONTROL ARM BUSHING KITS



XK6109

XK5196

Cost

XK5196.....70-72..... Upper
 XK6076.....70-72..... Lower, Circular holes
 XK5149.....70-72..... Lower, Oval holes
 XK6108.....73..... Upper
 XK6109.....73-77..... Lower
 XK6144.....74-77..... Upper

RETURN FUEL LINES

Return lines carry excess fuel from fuel pump or fuel filter back to the tank. Not all vehicles were equipped with a return line. They are typically made of 1/4" diameter tubing. Multiple piece sets are noted..



MGL7002

ADD "S" TO PART NUMBER FOR STAINLESS STEEL

MGL7002.... 70-72 1/4 Return Line
 MGL8802.... 80-88 1/4 Return Line, Carbureted
 MGL8804.... 81-88 5/16 Return, Fuel Injected

MONTE CARLO REAR BRAKE CONVERSIONS

**STREET
SERIES**

REAR DISC BRAKE CONVERSION KITS

REAR CONVERSIONS INCLUDE:

- 11" Rotors
- Caliper Brackets & Spacers
- Weld-On Hose Brackets
- Flex Hoses
- Backing Plates (Exclusive), not for AFXRD78 or AFXRDM78
- New Loaded Caliper
- E-Brake Cables
- Hardware

Right Stuff disc conversions are the most complete kits in the industry at the right price. High quality components, professional packaging, and after-sale support by "hands-on" technicians create an unbeatable value. Consider one of our complete brake line packages for a carefree installation. See page 82 to verify axle flange measurements for these kits.

WANT MATCHING FRONT UPGRADES?

SEE PAGE 82 FOR OUR REAR+2 CONVERSIONS

ATTENTION Before you order, be sure to measure the axle flange on your vehicle.

WORKS WITH 15" AND LARGER WHEELS

6 3/16" INSIDE ROTOR DIAMETER - 2.78" CENTER HOLE

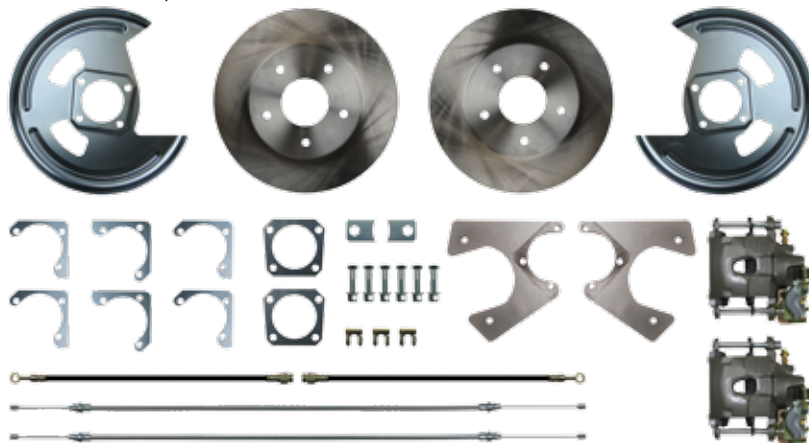

REAR KITS WITH E-BRAKE

AFXRD0170-77 10 & 12 Bolt
AFXRD7878-88 10 Bolt

REAR KITS WITHOUT E-BRAKE

AFXRDM170-77 10 & 12 Bolt
AFXRDM7878-88 10 Bolt

REAR DISC BRAKE CONVERSION UPGRADES

**STREET
SERIES**

SHOW'N GO UPGRADE TRIM PACKAGES

These Rear Disc Conversion Kits include upgraded drilled slotted rotors with zinc plating, powder coated calipers in red or black, and braided stainless hoses.



REAR KITS WITH E-BRAKE

AFXRD01S 70-77 10 & 12 Bolt - Black Calipers
AFXRD01Z 70-77 10 & 12 Bolt - Red Calipers
AFXRD78S 78-88 10 Bolt - Black Calipers
AFXRD78Z 78-88 10 Bolt - Red Calipers

REAR KITS WITHOUT E-BRAKE

AFXRDM1S 70-77 10 & 12 Bolt - Black Calipers
AFXRDM1Z 70-77 10 & 12 Bolt - Red Calipers
AFXRDM78S 78-88 10 Bolt - Black Calipers
AFXRDM78Z 78-88 10 Bolt - Red Calipers

SUSPENSION KITS

Standard rubber kits meet O.E. specifications. Polyurethane kits provide better handling and a firmer ride. Poly kits include upgraded control arm bushings, sway bar bushings, and sway bar links. Pre-packaged kits offer huge savings over individual suspension parts. Most kits include the following:

- Lower Ball Joints (2)
- Inner Tie Rods (2) (Extra Value)
- Lower Ctrl. Arm Bushings (4)
- Sway Bar Link Kits (2)
- Tie Rod Adj. Sleeves (2)
- Upper Ball Joints (2)



- MSK640170-72... Kit, Circular Hole in Ctrl. Arm, 22-Piece
- MSK6401U..70-72... Kit, Circular Hole in Ctrl. Arm, 22-Pc (Poly)
- MSK700170-72... Kit, Oval Hole in Ctrl. Arm, 22-Piece.
- MSK7001U..70-72... Kit, Oval Hole in Ctrl. Arm, 22-Pc (Poly)
- CSK7301 73 Front Rebuild Kit, 22-Piece
- CSK740174-75... Front Rebuild Kit, 22-Piece
- CSK760176-77... Front Rebuild Kit, 24-Piece with 1-1/8" & 1-3/16" Sway Bar with Tabs on Mounting Clamps
- CSK780178-88... Front Rebuild Kit, 24-Piece with 1" & 1-1/16" Sway Bar without Tabs on Mounting Clamps
- CSK780278-88... Front Rebuild Kit, 24-Piece with 1-1/8" & 1-1/4" Sway Bar without Tabs on Mounting Clamps
- CSK780378-88... Front Rebuild Kit, 24-Piece with 1-5/16" & 1-7/16" Sway Bar without Tabs on Mounting Clamps

MONTE CARLO REAR +2 BRAKE CONVERSIONS

**STREET
SERIES**

REAR +2 DISC BRAKE CONVERSION KITS

REAR +2 CONVERSIONS INCLUDE:

- 11" Drilled-Slotted-Zinc Rear Rotors
- Black or Red Rear Powder Coated Calipers
- Caliper Brackets, Spacers, Hardware
- Braided Stainless Rear Hoses
- Weld-On Hose Brackets
- Backing Plates *TRSD Exclusive
- E-Brake Cables

+2 KITS ALSO INCLUDE

- Drilled-Slotted-Zinc Front Rotors
- Black or Red Powder Coated Front Calipers
- Braided Stainless Front Hoses

Right Stuff disc conversions are the most complete kits in the industry at the right price. High quality components, professional packaging, and after-sale support by "hands-on" technicians create an unbeatable value. Get a rear conversion and matching front upgrades with a single part number.

NOTE:
FITS FACTORY
REAR ENDS
CALL FOR CUSTOM
APPLICATIONS



FRONT ROTORS
DRILLED & SLOTTED

WORKS WITH 15" AND LARGER WHEELS

REAR DISC BRAKES + MATCHING FRONT UPGRADES
6 3/16" INSIDE ROTOR DIAMETER - 2.78" CENTER HOLE

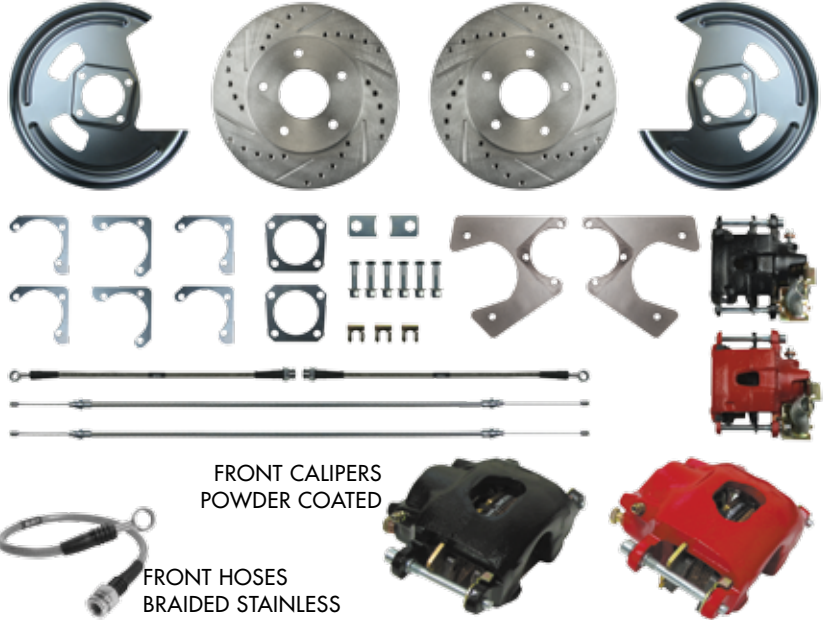

FRONT CALIPERS
POWDER COATED

FRONT HOSES
BRAIDED STAINLESS

REAR +2 KITS WITH E-BRAKE

- A69RD01S 70-72 Black Calipers, Drilled/Slotted
- A69RD01Z 70-72 Red Calipers, Drilled/Slotted
- A73RD01S 73-77 Black Calipers, Drilled/Slotted
- A73RD01Z 73-77 Red Calipers, Drilled/Slotted
- A78RD78S 78 Black Calipers, Drilled/Slotted
- A78RD78Z 78 Red Calipers, Drilled/Slotted
- A79RD78S 79-81 Black Calipers, Drilled/Slotted
- A79RD78Z 79-81 Red Calipers, Drilled/Slotted
- A82RD78S 82-88 Black Calipers, Drilled/Slotted
- A82RD78Z 82-88 Red Calipers, Drilled/Slotted

REAR +2 KITS WITHOUT E-BRAKE

- A69RDM1S..... 70-72Black Calipers, Drilled/Slotted
- A69RDM1Z 70-72Red Calipers, Drilled/Slotted
- A73RDM1S..... 73-77Black Calipers, Drilled/Slotted
- A73RDM1Z 73-77Red Calipers, Drilled/Slotted
- A78RDM78S.....78Black Calipers, Drilled/Slotted
- A78RDM78Z78Red Calipers, Drilled/Slotted
- A79RDM78S... 79-81Black Calipers, Drilled/Slotted
- A79RDM78Z .. 79-81Red Calipers, Drilled/Slotted
- A82RDM78S... 82-88Black Calipers, Drilled/Slotted
- A82RDM78Z .. 82-88Red Calipers, Drilled/Slotted

AXLE FLANGE DIAGRAMS

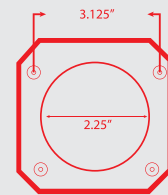
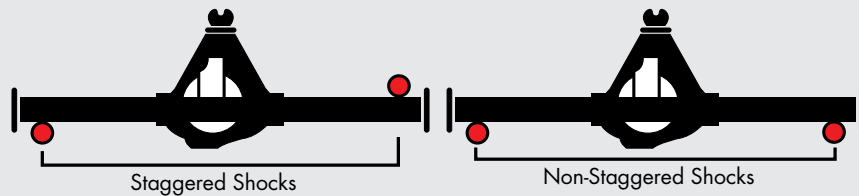

GM
AFXR01 & AFXRD05
AFXRD06 & AFXRD07

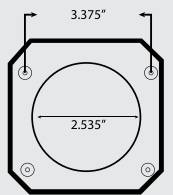

GM
FSCRD01

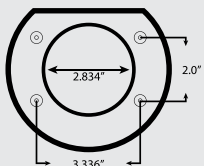

**FORD SMALL
9" or 8"**
ZDCRD02

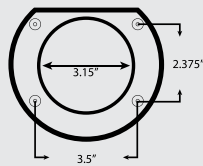

**FORD LARGE 9"
OLDSTYLE**
ZDCRD01 & ZDCRD05

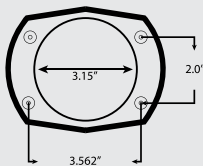

**FORD LARGE 9"
NEW TORINO STYLE**
ZDCRD01 & ZDCRD05

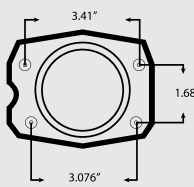

8.8" FORD
ZDCRD03

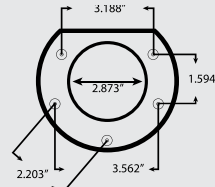

**8 3/4" and 9 3/4"
MOPAR - DANA 60**
MDCRD01

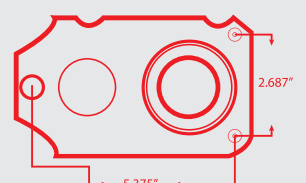

GM
AFXRD78

MONTE CARLO PERFORMANCE BRAKE CONVERSIONS



COMPLETE DISC BRAKE CONVERSION KITS



U.S.A. Made
TIMKEN Bearings

Right Stuff Performance Series disc conversions are the most complete kits in the industry at the right price. Designed for the performance street machine with high quality components, professional packaging, and after-sale support by "hands-on" technicians and many DIY videos at rightstuff create an unbeatable value.

Kits are available as a **Disc Brake Upgrade** that bolts to stock front disc brake spindles, or as an **At-The-Wheel Kit** that includes everything for a front disc brake conversion, and as a **Complete Conversion Kit** which includes everything in the At-The-Wheel Kit with the addition of the master cylinder, booster and prop valve (Power or Manual).

AT-THE-WHEEL CONVERSION KITS INCLUDE:

- 11" Drilled & Slotted Rotors
- Wilwood Dual Piston Calipers
- Caliper Brackets
- Backing Plates
- Timken Bearings
- Castle Nuts & Pins
- Dust Caps
- Forged Spindles
- Organic Pads
- Washers
- Grease Seals
- Spindle Gaskets
- Steering Arm Bolts
- Hardware

COMPLETE CONVERSION KITS ALSO INCLUDE

- Master Cylinder - Chrome or Standard Finish
- Flex Hoses & Clips
- Valve Bracket & Hardware
- Banjo Bolts & Copper Washers
- Combination Valve
- Brake Switch Pigtail
- Pedal Rod Extension



RCP70S

DISC BRAKE UPGRADE KITS INCLUDE (Kit is Designed to Bolt to Stock Disc Brake Spindles)

- Wilwood 2-Piston Aluminum Calipers
- Cross-Drilled & Slotted Zinc Plated Rotors
- Braided Stainless Hoses
- Organic Brake Pads

DISC BRAKE UPGRADE KITS

- RCP69S70-72..... Black 2-Piston Wilwood Calipers
- RCP69Z70-72..... Red 2-Piston Wilwood Calipers
- RCP70S73-77..... Black 2-Piston Wilwood Calipers
- RCP70Z73-77..... Red 2-Piston Wilwood Calipers

WORKS WITH 15" AND LARGER WHEELS

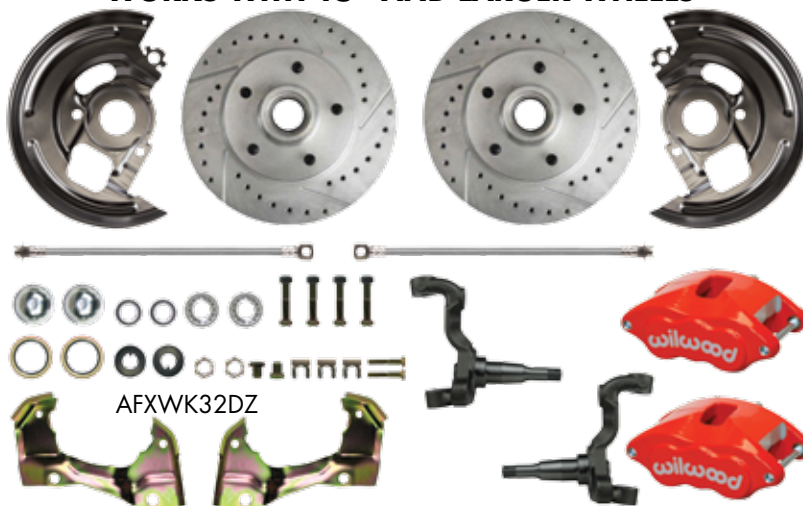

AFXWK32DZ

FRONT AT-THE-WHEEL KITS

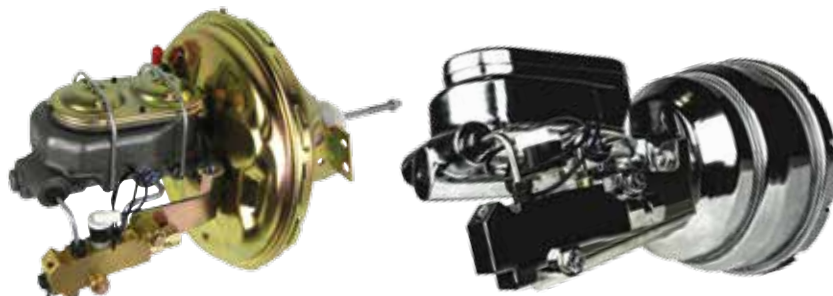

STANDARD PACKAGE

CHROME PACKAGE

Packages include At-the-Wheel Disc Conversion Kits and Chrome or Standard Finish Master Cylinder with Booster and Valve (Power).

AT-THE-WHEEL FRONT DISC KITS

- AFXWK32S..... 64-72....At-the-Wheel Stock Height - Black Wilwood
- AFXWK32Z 64-72....At-the-Wheel Stock Height - Red Wilwood
- AFXWK32DS ... 64-72....At-the-Wheel 2" Drop - Black Wilwood
- AFXWK32DZ ... 64-72....At-the-Wheel 2" Drop - Red Wilwood

STOCK HEIGHT FRONT KITS

- AFXDC32S.....64-72 Standard Booster/Master - Black Wilwood
- AFXDC32Z64-72 Standard Booster/Master - Red Wilwood
- AFXDC32SX.....64-72 Chrome Booster/Master - Black Wilwood
- AFXDC32ZX.....64-72 Chrome Booster/Master - Red Wilwood

2" DROP FRONT KITS

- AFXDC32DS 64-72... Standard Booster/Master - Black Wilwood
- AFXDC32DZ 64-72... Standard Booster/Master - Red Wilwood
- AFXDC32DSX... 64-72... Chrome Booster/Master - Black Wilwood
- AFXDC32DZX .. 64-72... Chrome Booster/Master - Red Wilwood

MONTE CARLO SIGNATURE SERIES CONVERSIONS



DISC BRAKE CONVERSION KITS

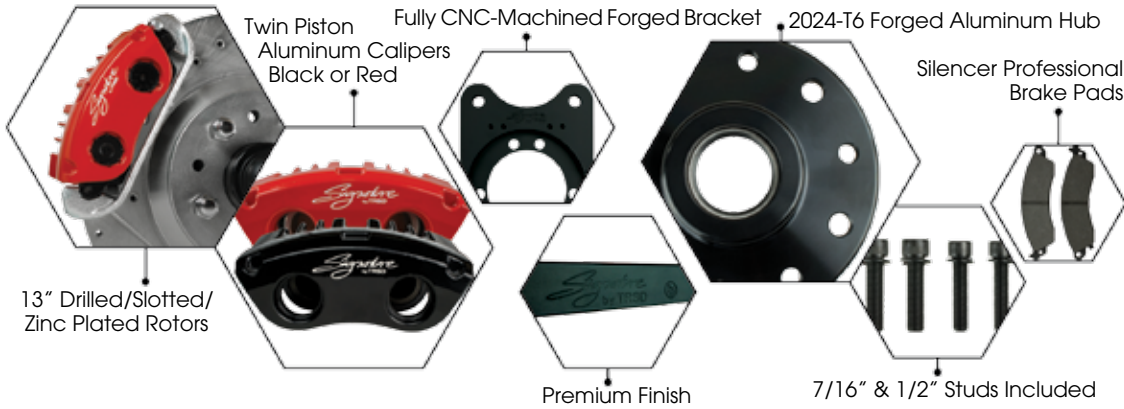

DESIGNED FOR 17" & LARGER WHEELS

Bold looks define the Signature Series line of brake kits. Large diameter zinc plated rotors, powder coated calipers, fully machined caliper brackets, & braided stainless brake hoses. Only premium quality components make the grade. We back every kit with industry leading technical support. Signature Series kits are amazing brakes at a great price. Add a No Brainer Brake Line Kit for a true bolt-on install.

SIGNATURE SERIES FRONT KIT

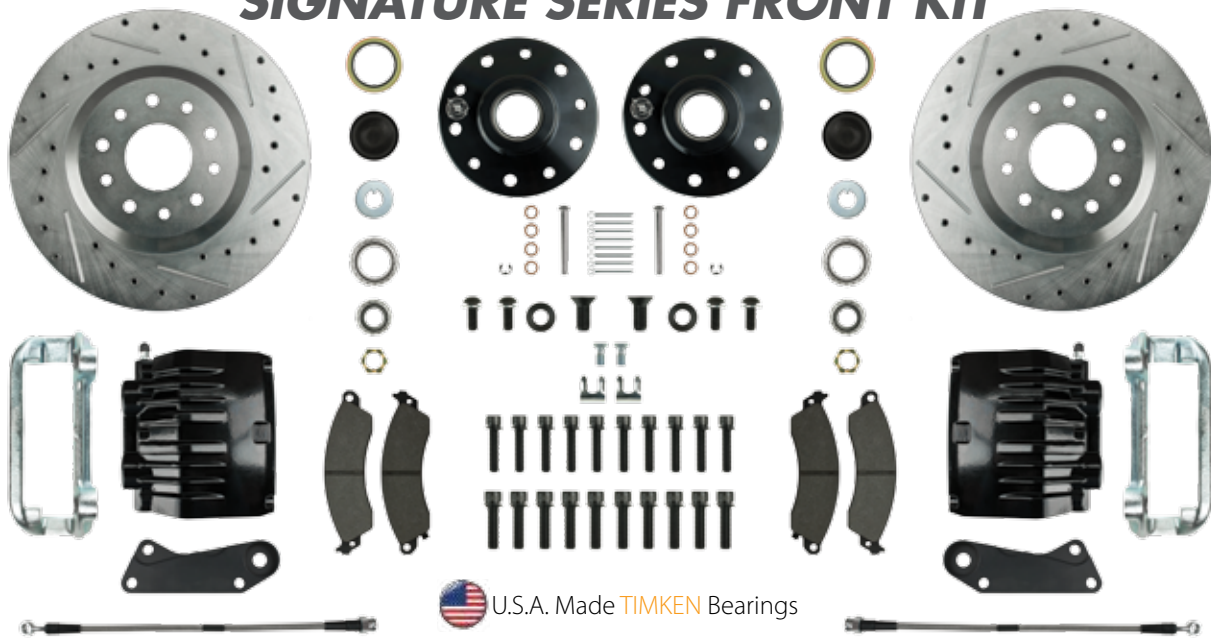

U.S.A. Made **TIMKEN** Bearings

STOCK HEIGHT FRONT KITS

Uses existing drum or disc brake spindles

- AFXWK31CS 64-72At-the-Wheel Kit - Black Calipers
- AFXWK31CZ 64-72At-the-Wheel Kit - Red Calipers
- AFXSD31CS..... 64-72Manual Kit - Black Calipers
- AFXSD31CZ..... 64-72Manual Kit - Red Calipers
- AFXDC31CS 64-72Power Kit - Black Calipers
- AFXDC31CZ 64-72Power Kit - Red Calipers

2" DROP FRONT KITS

Includes new 2" drop spindles

- AFXWK31DS 64-72At-the-Wheel Kit - Black Calipers
- AFXWK31DZ 64-72At-the-Wheel Kit - Red Calipers
- AFXSD31DS..... 64-72Manual Kit - Black Calipers
- AFXSD31DZ..... 64-72Manual Kit - Red Calipers
- AFXDC31DS 64-72Power Kit - Black Calipers
- AFXDC31DZ 64-72Power Kit - Red Calipers

STOCK HEIGHT 4-WHEEL KITS

Stock Height - Non-Staggered Shocks

- AFXWK51CS 64-72At-the-Wheel Kit - Black Calipers
- AFXWK51CZ 64-72At-the-Wheel Kit - Red Calipers
- AFXSD51CS..... 64-72Manual Kit - Black Calipers
- AFXSD51CZ..... 64-72Manual Kit - Red Calipers
- AFXDC51CS 64-72Power Kit - Black Calipers
- AFXDC51CZ 64-72Power Kit - Red Calipers

2" DROP 4-WHEEL KITS

Stock Height - Non-Staggered Shocks

- AFXWK51DS 64-72At-the-Wheel Kit - Black Calipers
- AFXWK51DZ 64-72At-the-Wheel Kit - Red Calipers
- AFXSD51DS..... 64-72Manual Kit - Black Calipers
- AFXSD51DZ..... 64-72Manual Kit - Red Calipers
- AFXDC51DS 64-72Power Kit - Black Calipers
- AFXDC51DZ 64-72Power Kit - Red Calipers

MONTE CARLO BRAKE CONVERSION UPGRADES

X-TRIM DISC BRAKE CONVERSION UPGRADES



Start turning heads with a show finished upper assembly. Manual kits get a chrome plated master cylinder and combination valve with bracket. Power kits also include an 8" dual chrome booster.



STOCK HEIGHT FRONT KITS

Uses existing drum or disc brake spindles

- AFXSD31CSX64-72.....Manual Kit - Black Calipers
- AFXSD31CZX64-72.....Manual Kit - Red Calipers
- AFXDC31CSX64-72.....Power Kit - Black Calipers
- AFXDC31CZX64-72.....Power Kit - Red Calipers

2" DROP FRONT KITS

Includes new 2" drop spindles

- AFXSD31DSX64-72.....Manual Kit - Black Calipers
- AFXSD31DZX64-72.....Manual Kit - Red Calipers
- AFXDC31DSX64-72.....Power Kit - Black Calipers
- AFXDC31DZX64-72.....Power Kit - Red Calipers

STOCK HEIGHT 4-WHEEL KITS

Stock Height - Non-Staggered Shocks

- AFXSD51CSX64-72.....Manual Kit - Black Calipers
- AFXSD51CZX64-72.....Manual Kit - Red Calipers
- AFXDC51CSX64-72.....Power Kit - Black Calipers
- AFXDC51CZX64-72.....Power Kit - Red Calipers

2" DROP 4-WHEEL KITS

Stock Height - Non-Staggered Shocks

- AFXSD51DSX64-72.....Manual Kit - Black Calipers
- AFXSD51DZX64-72.....Manual Kit - Red Calipers
- AFXDC51DSX64-72.....Power Kit - Black Calipers
- AFXDC51DZX64-72.....Power Kit - Red Calipers



REAR DISC BRAKE CONVERSION KITS

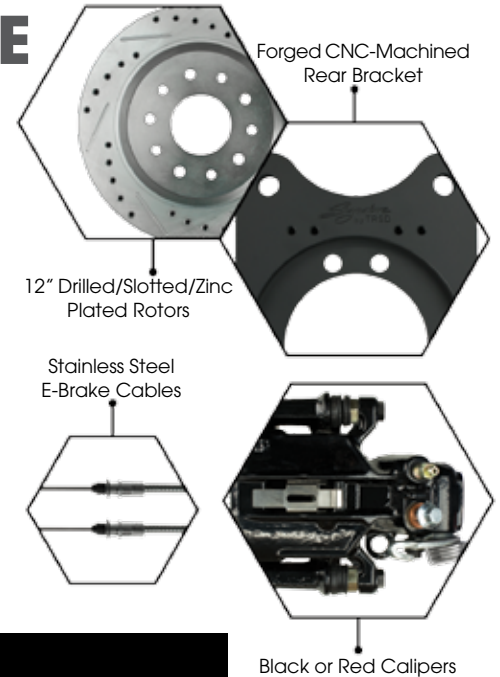
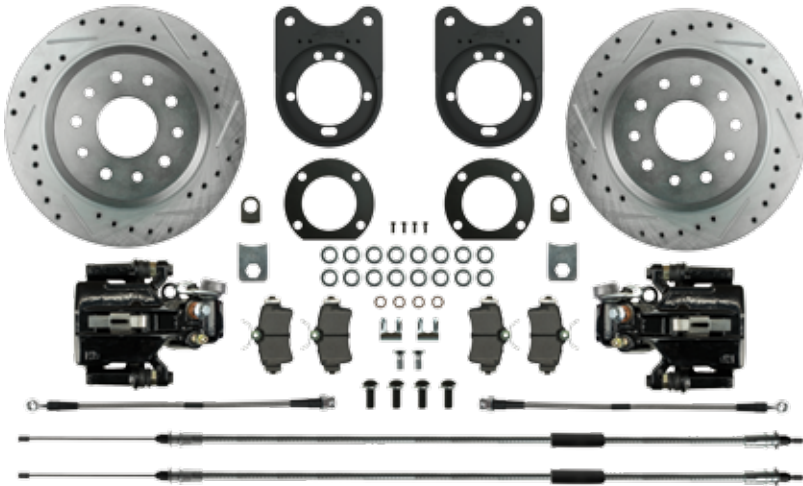

KITS FIT AXLES WITH 3-1/8" FLANGE ONLY

REAR DISC CONVERSION KITS

AFXRD31S64-77 Rear Disc Conversion - Black

AFXRD31Z64-77 Rear Disc Conversion - Red

1936-57 CHEVY BRAKE LINES & HOSES

FRONT BRAKE LINE KITS

Front brake line kits consist of all brake lines under the hood. This includes the master cylinder to the distribution, combination or metering valve. The left and right front lines that run to the front flex hoses are also included. Call for individual component pricing. These line kits are for vehicles with factory brake systems.

ADD "S" TO PART NUMBER FOR STAINLESS STEEL

BKT3801 38.....Standard Drum
 BKT4101 41-42Standard Drum
 BKT5001 49-50Standard Drum
 BKT5101 51.....Standard Drum
 BKT5201 52.....Standard Drum

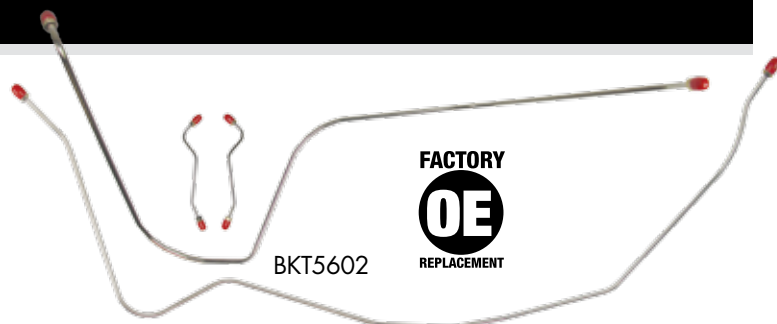

BKT5301 53-54Standard Drum 3 Pcs.
 BKT5501 55.....Standard Drum 4 Pcs.
 BKT5502 55.....Power Drum 4 Pcs.
 BKT5601 56-57Standard Drum 4 Pcs.
 BKT5602 56-57Power Drum 4 Pcs.

REAR BRAKE LINE KITS

Front to rear brake lines go from the distribution, combination or metering valve along the length of the vehicle to the rear flex hose. Lines are manufactured in 1 or 2 pieces based on factory specifications.

ADD "S" TO PART NUMBER FOR STAINLESS STEEL

BIN3801 38..... All Cars, 2-Piece.
 BIN4101 41-42 All Cars
 BIN5001 49-50 All Cars
 BIN5201 51-52 All Cars
 BIN5301 53-54 All Cars

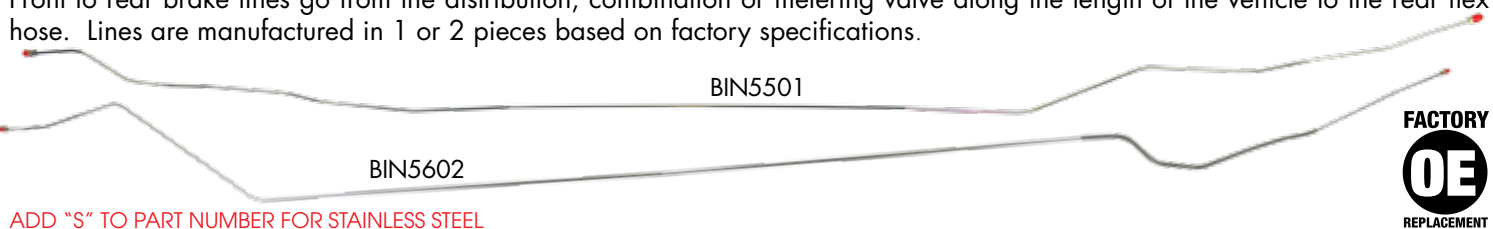

BIN5501 55 Single Exhaust
 BIN5502 55 Dual Exhaust
 BIN5601 56-57 Single Exhaust
 BIN5602 56-57 Dual Exhaust
 BIN5704 57 4 Door Wagon

REAR AXLE BRAKE LINES

Rear axle brake lines include a pair of lines that run across the rear axle housing. These lines connect the wheel cylinders or calipers to the flex hose in the middle of the rear end. These lines work with original housings that use factory brakes. Modifications such as rear disc brakes or narrowed rear ends will likely require special lines. Call for more information.

ADD "S" TO PART NUMBER FOR STAINLESS STEEL

BRA3801 38All Cars
 BRA4101 41-42All Cars
 BRA5001 49-50All Cars
 BRA5201 51-52All Cars
 BRA5301 53-54All Cars
 BRA5501 55-57All Cars

FRONT FLEX HOSES

Front flex hoses provide a flexible connection from the body or frame to the front calipers or wheel cylinders as they move during suspension travel. Choose between O.E. rubber or braided stainless steel. All of our hoses are D.O.T. approved. Hoses are priced individually.

ADD "S" TO PART NUMBER FOR STAINLESS STEEL

FH117 37-50Front, All
 FH39 51-54Front, All
 FH38 55-57Front, All

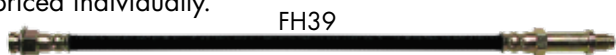

REAR FLEX HOSES

Rear flex hoses carry brake fluid between the body of the car and the rear. Hoses are available in O.E. rubber and braided stainless steel. 'T' blocks are attached whenever factory correct. All of our hoses are D.O.T. approved. Prices are per hose.

ADD "S" TO PART NUMBER FOR STAINLESS STEEL

FH117 37-50Rear, All
 FH39 51-57Rear, All
 RSBB08 37-57Rear Hose Brass 'T' Block w/ Slot



1936-57 CHEVY BRAKE BOOSTERS

SLIMLINE BOOSTER MASTER COMBOS

J81315672

The slimline combos offer clean lines and plenty of power in a small package. The 8" dual is our favorite. Mounting brackets included.



J81315672 TOP VIEW

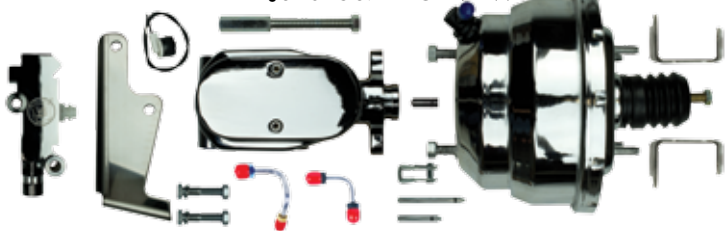

- G82310971 55-57 Gold 8" Dual, Disc/Drum
- J82315171 55-57 Chrome 8" Dual Disc/Drum
- G82310572 55-57 Gold 8" Dual, Disc/Disc
- J82315672 55-57 Chrome 8" Dual Disc/Disc
- G92020971 55-57 Gold 9" Single, Disc/Drum

SLIMLINE BOOSTERS

Slimline boosters pack a lot of punch in a small, sleek package. Dual diaphragm versions provide 25% - 35% more assist than their single diaphragm equivalent. The 8" dual is our most popular for clearing big blocks while providing plenty of assist for two or four wheel disc brake systems. Mounting brackets included.



RPB7137



RPB7137C



RPB8131



RPB8131C

- RPB7237 55-57 7" Dual, Gold
- RPB7237C 55-57 7" Dual, Chrome
- RPB7237S 55-57 7" Dual, Stainless
- RPB8231 55-57 8" Dual, Gold
- RPB8231C 55-57 8" Dual, Chrome
- RPB8231S 55-57 8" Dual, Stainless
- RPB9202 55-57 9" Single, Gold

DELCO BOOSTER MASTER COMBOS

These combos have a factory looking appearance. Can be tight on big block cars. Mounting brackets included.



G92210971 TOP VIEW

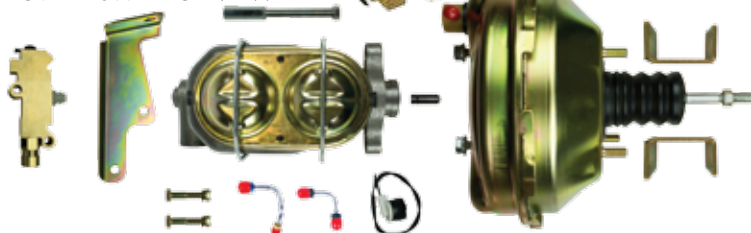

- G92210971 55-57 Gold 9" Single Disc/Drum
- J92215171 55-57 Chrome 9" Single, Disc/Drum
- G92210572 55-57 Gold 9" Single Disc/Disc
- J92215672 55-57 Chrome 9" single, Disc/Disc

DELCO BOOSTERS

These boosters are reproductions based on original factory units. Mounting brackets included.



RBP9221

RBP9221C

- RBP9221 55-57 9" Single, Gold
- RBP9221C 55-57 9" Single, Chrome

THERMAL CHOKE LINES

Thermal choke lines carry heat from the exhaust system to the choke coil on the carburetor. Some applications route thru the intake manifold on their way to the carburetor.

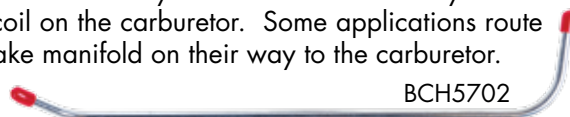

BCH5702

ADD "S" TO PART NUMBER FOR STAINLESS STEEL

- BCH5501 55-56 6 Cylinder, 235
- BCH5502 55-56 8 Cylinder with 2 BBL
- BCH5503 55-56 8 Cylinder with Carter 4 BBL
- BCH5701 57 6 Cylinder
- BCH5702 57 8 Cylinder with 2 BBL
- BCH5703 57 8 Cylinder with 4 BBL
- BCH5704 57 8 Cylinder with 2 x 4 Carbs.

1936-57 CHEVY BRAKE COMPONENTS

MASTER CYLINDERS

Most master cylinders are completely new units with no core charge. A deep cylinder pocket with a removable plug provides compatibility with manual brakes as well as power-assisted applications.



- DBMC09 55-57 Power Disc, 1-1/8" Bore, Deep Pocket
- DBMC01 55-57 Power Disc, 1-1/8" Bore, Shallow Pocket
- DBMC09C 55-57 1-1/8" Bore, Chrome
- DBMC05C 55-57 1" Bore, 4 Wheel Disc, Chrome
- DBMC51C 55-57 1-1/8" Bore, Slimline Flat Top, Chrome
- DBMC56C 55-57 1" Bore, Slimline Flat Top, Chrome

VALVES & BLOCKS

We offer a full line of metering blocks, proportioning valves, distribution blocks and combination valves for factory drum and disc brake applications.



- PV01 55-57 Adjustable Valve
- PV71 55-57 Disc/Drum Combination Valve, Brass
- PV71C 55-57 Disc/Drum Combination Valve, Chrome
- PV72 55-57 Disc/Disc Combination Valve, Brass
- PV72C 55-57 Disc/Disc Combination Valve, Chrome
- PVB71 55-57 Side Mount Bracket
- PVB71S 55-57 Side Mount Bracket, Polished Stainless

BRAKE DRUMS

Brake drums are sold individually.



- BD14 51-57 Front or Rear Drum, Non-Finned

FUEL PUMP TO CARB LINES

Fuel pump to carburetor lines connect the fuel pump to the carburetor. Brass blocks and fittings are included as noted. These lines are intended to work only with factory pump, motor, intake and carburetor combinations.

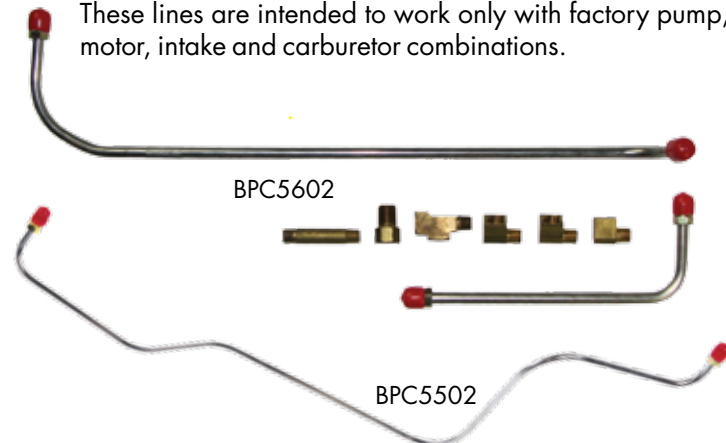

ADD "S" TO PART NUMBER FOR STAINLESS STEEL

- BPC3601 36 Master, 206.8
- TPC3701 37 216
- BPC3801 38 216
- BPC5101 47-51 235, 6 Cylinder
- BPC5502 55 8 Cylinder, 2 BBL or 4 BBL, 1/4"
- BPC5503 55 235, 6 Cylinder 2 Lines 5/16" & 3/16"
- BPC5501 55-57 6 Cylinder
- BPC5602 56 V-8, Dual 4 BBL, 2 Lines & 6 Fittings
- BPC5601 56-57 8 Cylinder, 2 BBL or 4 BBL, 5/16"
- BPC5701 57 V-8, Dual 4 BBL, 2 Lines & 6 Fittings
- BPC5702 57 Fuel Injection, 2 Lines and 4 Fittings

SILICON BRAKE FLUID



- SBF001 Brake Fluid qt.

WHEEL CYLINDERS

Wheel cylinders are priced each. Hardware is not included.



- WC34 51-52 Left Front
- WC35 51-52 Right Front
- WC47 51-52 Left & Right Rear
- WC11 55-57 Left Rear
- WC12 55-57 Right Rear
- WC13 55-57 Left Front
- WC14 55-57 Right Front

1936-57 CHEVY TRANSMISSION & FUEL LINES

MAIN FUEL LINES

Main lines carry fuel from the tank in the rear of the car to the fuel pump or rail in the front. They are available in 3/8" and 5/16" tubing based on factory specifications. Multiple piece sets are noted. Call for 1/2" lines.

BGL5505

ADD "S" TO PART NUMBER FOR STAINLESS STEEL

TGL3701 37.....5/16" All Cars
 BGL3801 38.....5/16" All Cars
 BGL4101 41-425/16", All Cars
 BGL5001 49-505/16", All Cars
 BGL5101 51.....5/16", 6 Cylinder
 BGL5302 53-54Sedan Delivery & Station Wagon
 BGL5501 55-575/16", 6 Cylinder

ADD "S" TO PART NUMBER FOR STAINLESS STEEL

BGL550255-57 5/16", V-8, 2 BBL, Except Convertible
 BGL553255-57 3/8", V-8, 2 BBL, Except Convertible
 BGL553855-57 3/8", V-8, 2 BBL, Convertible Only
 BGL550355-57 5/16", V-8, 2 BBL, Convertible Only
 BGL550455-57 5/16", V-8, 4 BBL, Power Pack
 BGL550555-57 3/8", V-8, Fuel Injection
 BGL550555-57 3/8", V-8, Dual, 4 BBL
 BGL550655-57 Nomad
 BGL570457 5/16", 4 Door Wagon

TRANSMISSION COOLER LINES

Transmission cooler lines are sold as pairs. Be sure to verify the type of transmission in your project before ordering. These lines are intended to work only with factory motor, transmission, and radiator combinations.

BTC5502

ADD "S" TO PART NUMBER FOR STAINLESS STEEL

BTC5101 51.....6 Cylinder
 BTC5502 55-568 Cylinder, Powerglide
 BTC5501 55-576 Cylinder, Powerglide
 BTC5503 55-57Small Block with T-350 or 400
 BTC5504 55-57Big Block with T-350 or 400
 BTC5505 55-57Big Block with 700-R4
 BTC5701 57.....8 Cylinder, Powerglide
 BTC5702 57.....Bel-Air Turbo, 3 Speed, Aluminum

TRANSMISSION VACUUM LINES

Transmission vacuum lines connect automatic transmissions to intake vacuum.

BTV5101 51235, 6 Cylinder - OE Steel
 BTV5101S 51235, 6 Cylinder - Stainless



SUSPENSION PARTS

Standard rubber kits meet O.E. specifications. Polyurethane kits provide better handling and a firmer ride. Poly kits include upgraded control arm bushings, sway bar bushings, and sway bar links.

UPPER & LOWER BALL JOINTS

XK67055-57Lower
 XK603455-57Upper



XK6034

COMING IN 2017

UPPER & LOWER CONTROL ARM BUSHING KITS

XK519655-57Upper, 2 Pcs.
 XK30455-57Lower, 4 Pcs.



XK304



XK5196



INNER & OUTER TIE RODS & SLEEVES

XES57755-57Inner, Pass Side
 XES57755-57Outer, Driver Side, Manual Steering
 XES234RL55-57Outer, Pass Side
 XES234RL55-57Inner, Driver Side
 XES577S55-57Adjusting Sleeve

1951-57 CHEVY SUSPENSION & FUEL TANKS

DISTRIBUTOR VACUUM LINES

Distributor vacuum lines supply intake vacuum to the distributor for timing control.

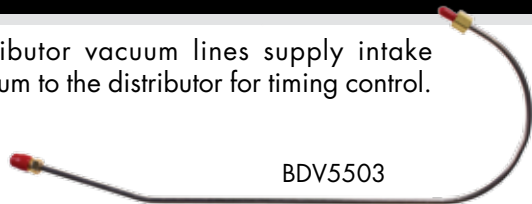

BDV5503

ADD "S" TO PART NUMBER FOR STAINLESS STEEL

- BDV3601 36 Master 206.8
- BDV3801 38 216
- BDV4901 49 6 Cylinder
- BDV5101 51 235, 6 Cylinder
- BDV5501 55-57 6 Cylinder
- BDV5502 55-57 8 Cylinder with 2 BBL
- BDV5503 55-57 8 Cylinder with Carter 4 BBL
- BDV5504 55-57 8 Cylinder with Rochester 4 BBL

FUEL SENDING UNITS

Sending units include floats, gaskets and snap rings where applicable. Our fuel senders are made of stainless steel and operate on the same ohm range as factory gauges.



BSU5502

- BSU5501 55-57 5/16" Main Line
- BSU5502 55-57 3/8" Main Line



SUSPENSION KITS

COMING IN 2017

These prepackaged kits offer huge savings over individual suspension parts. Most kits include the following:

- Lower Ball Joints (2)
- Upper Ball Joints (2)
- Upper Ctrl. Arm Bushings (4)
- Tie Rod Adj. Sleeves (2)
- Lower Ctrl. Arm Bushings (4)
- Inner Tie Rods (2)

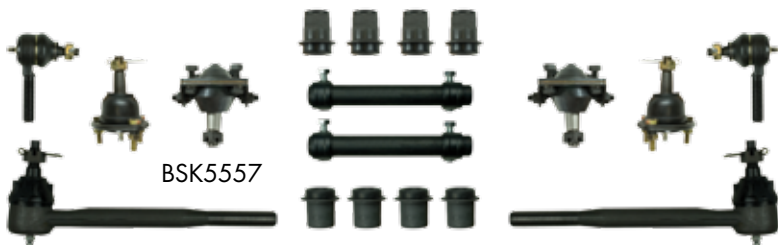

BSK5557

- BSK5557 55-57 ... with Manual Steering, 18 Pieces - Standard
- BSK5557 55-57 ... with Manual Steering, 18 Pieces - Poly
- BSK5557N ... 55-57 ... with Power Steering, 16 Pieces - Standard
- BSK5557N ... 55-57 ... with Power Steering, 16 Pieces - Poly

FUEL TANKS

Fuel tanks are constructed of Ni-Terne steel. Hardware is not included.



BFT5506



BFT5501

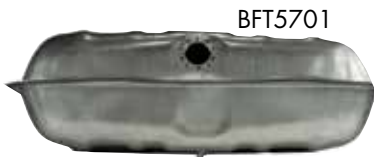

BFT5701



- BFT5501 55-56 Chevy (Excludes Wagon), Round Weld, No Filler Neck
- BST5501 ... 55-56 Chevy (Excludes Wagon), Round Weld, No Filler Neck - Stainless
- BFT5502 55-56 Chevy (Excludes Wagon), Square Weld, No Filler Neck
- BST5502 ... 55-56 Chevy (Excludes Wagon), Square Weld, No Filler Neck - Stainless
- BFT5701 57 Chevy (Excludes Wagon), Round Weld, No Filler Neck
- BST5701 57 Chevy (Excludes Wagon), Round Weld, No Filler Neck - Stainless
- BFT5702 57 Chevy (Excludes Wagon), Square Weld, No Filler Neck
- BST5702 57 Chevy (Excludes Wagon), Square Weld, No Filler Neck - Stainless

FUEL HOSE KITS

These small rubber hoses and clips are used to connect fuel lines to the fuel pump and sending unit.



FHK3800

- FHK3800 ALL 3/8" x 6", 3/8" x 13", + 4 Green Clamps
- BFH5504 55-57 5/16", Used with BGL5501, 02, 03, 04
- BFH5505 55-57 3/8", Used with BGL5505



1955-57 CHEVY FRONT BRAKE CONVERSIONS

**STREET
SERIES**

FRONT DISC BRAKE CONVERSION KITS

U.S.A. Made
TIMKEN Bearings

FRONT CONVERSIONS INCLUDE:

- 11" Rotors
- Spindles (2" Drop Only)
- Timken Bearings
- New Calipers
- Caliper Brackets
- Organic Pads
- Backing Plates
- Flex Hoses & Clips
- Valve Bracket & Hardware
- Banjo Bolts & Copper Washers
- Dust Caps
- Castle Nuts & Pins
- Washers
- Grease Seals
- Spindle Gaskets
- Steering Arm Bolts
- Master Cylinder
- Combination Valve
- Pedal Rod Extension
- Brake Switch Pigtail

Kits have an offset of 3/8" per side. For zero offset kit option, see page 97.

Right Stuff disc conversions are the most complete kits in the industry at the right price. High quality components, professional packaging, and after-sale support by "hands-on" technicians create an unbeatable value. Consider one of our complete brake line packages for a carefree installation.



Packages include At-the-Wheel Disc Conversion Kit & Master Cylinder with Valve (Manual) or Master Cylinder with Booster and Valve (Power).

POWER PACKAGE

MANUAL PACKAGE

9" inch booster, Call for other diameters

UPGRADES

The next page offers upgrades to fully customize your conversion kit.

FITS 15" & LARGER WHEELS



AT-THE-WHEEL FRONT KITS From 341.25

STOCK HEIGHT FRONT KITS

- FSC55WKC ... 55-57 ... At-the-Wheel Disc Conversion Kit
- FSC55SDC..... 55-57 ... Manual Disc Conversion Package
- FSC55DCC 55-57 ... Power Disc Conversion Package

2" DROP FRONT KITS

- FSC55WKD ... 55-57 ... 2" Drop At-the-Wheel Disc Conversion Kit
- FSC55SDD..... 55-57 ... 2" Drop Manual Disc Conversion Package
- FSC55DCD 55-57 ... 2" Drop Power Disc Conversion Package



1955-57 CHEVY FRONT BRAKE UPGRADES

FRONT DISC BRAKE CONVERSION UPGRADES

STREET SERIES

SHOW'N GO UPGRADE TRIM KITS

These At-the-Wheel Disc Conversion Kits (stock height or 2" drop) include upgraded drilled slotted rotors with zinc plating, powder coated calipers in red or black, and braided stainless hoses.



STOCK HEIGHT SHOW'N GO

FSC55WKCS ... 55-57 ...At-the-Wheel Disc Conversion Kit - Black
 FSC55WK CZ ... 55-57 ...At-the-Wheel Disc Conversion Kit - Red
 FSC55SDCS..... 55-57 ...Manual Disc Conversion Package - Black
 FSC55SDCZ..... 55-57 ...Manual Disc Conversion Package - Red
 FSC55DCCS 55-57 ...Power Disc Conv pkg - 9" Booster - Black
 FSC55DCCZ 55-57 ...Power Disc Conv Pkg - 9" Booster - Red

2" DROP SHOW'N GO

FSC55WKDS .55-57 ..2" Drop At-the-Wheel Disc Convn Kit - Blk
 FSC55WKDZ .55-57 ..2" Drop At-the-Wheel Disc Conv Kit - Red
 FSC55SDDS...55-57 ..2" Drop - Manual Disc Conversion Package - Black
 FSC55SDDZ...55-57 ..2" Drop - Manual Disc Conversion Package - Red
 FSC55DCDS ..55-57 ..2" Drop - Power Disc Conv Pkg - 9" Booster - Black
 FSC55DCDZ ..55-57 ..2" Drop - Power Disc Conv Pkg - 9" Booster - Red

SHOW STOPPER TRIM PACKAGES

Includes At-the-Wheel Front Disc Conversion Kit (stock height or 2" drop) with natural finish calipers. The Manual Packages get an upgraded chrome plated master cylinder and combination valve with bracket. Power Packages include an upgraded 8" dual chrome booster.



STOCK HEIGHT SHOW STOPPER

FSC55SDCX..... 55-57 ...Manual Disc Conversion Package
 FSC55DCCX 55-57 ...Power Disc Conversion Package

2" DROP SHOW STOPPER

FSC55SDDX..... 55-57 ...2" Drop Manual Disc Conversion Package
 FSC55DCDX 55-57 ...2" Drop Power Disc Conversion Package

BEST OF SHOW TRIM PACKAGES

Includes At-the-Wheel Front Disc Conversion Kit (stock height or 2" drop) with black or red calipers, drilled & slotted rotors & braided stainless hoses. The Manual Packages get an upgraded chrome plated master cylinder and combination valve with bracket. Power Packages include an upgraded 8" dual chrome booster.



STOCK HEIGHT BEST OF SHOW

FSC55SDCSX..... 55-57 ...Manual Disc Conversion Package - Black
 FSC55SDCZX..... 55-57 ...Manual Disc Conversion Package - Red
 FSC55DCCSX ... 55-57 ...Power Disc Conversion Package - Black
 FSC55DCCZX ... 55-57 ...Power Disc Conversion Package - Red

2" DROP BEST OF SHOW

FSC55SDDSX....55-57 ... 2" Drop Manual Disc Conv Package - Black
 FSC55SDDZX....55-57 ... 2" Drop Manual Disc Conv Package - Red
 FSC55DCDSX ...55-57 ... 2" Drop Power Disc Conv Package - Black
 FSC55DCDZX ...55-57 ... 2" Drop Power Disc Conv Package - Red



Disc Brake Conversions require special brake lines that fit your new disc conversion setup. Right Stuff offers "No Brainer" Brake Line Kits that include all components needed from your master cylinder back to your rear wheel cylinder or calipers. They include front brake line kit, front to rear line, rear axle lines & flex hose, & clip set.

See page 99 for your application

1955-57 CHEVY 4-WHEEL BRAKE CONVERSIONS

**STREET
SERIES**

FOUR WHEEL DISC BRAKE CONVERSION KITS

U.S.A. Made
TIMKEN Bearings

FOUR WHEEL CONVERSIONS INCLUDE:

- 11" Rotors
- Forged Spindles (2" Drop Only)
- Timken Bearings
- New Calipers
- Caliper Brackets
- Organic Pads
- Backing Plates
- Flex Hoses & Clips
- Valve Bracket & Hardware
- Banjo Bolts & Copper Washers
- Rear Bracket Spacers
- Weld-On Hose Brackets
- Dust Caps
- Castle Nuts & Pins
- Washers
- Grease Seals
- Spindle Gaskets
- Steering Arm Bolts
- Master Cylinder
- Combination Valve
- Pedal Rod Extension
- Brake Switch Pigtail
- E-Brake Cables

Kits have an offset of 3/8" per side. For zero offset kit option, see page 97.

Right Stuff disc conversions are the most complete kits in the industry at the right price. High quality components, professional packaging, and after-sale support by "hands-on" technicians create an unbeatable value. Consider one of our complete brake line packages for a carefree installation. See page 98 to verify axle flange measurements for these kits.



POWER PACKAGE



MANUAL PACKAGE

WORKS WITH 15" AND LARGER WHEELS



AT-THE-WHEEL FRONT KIT

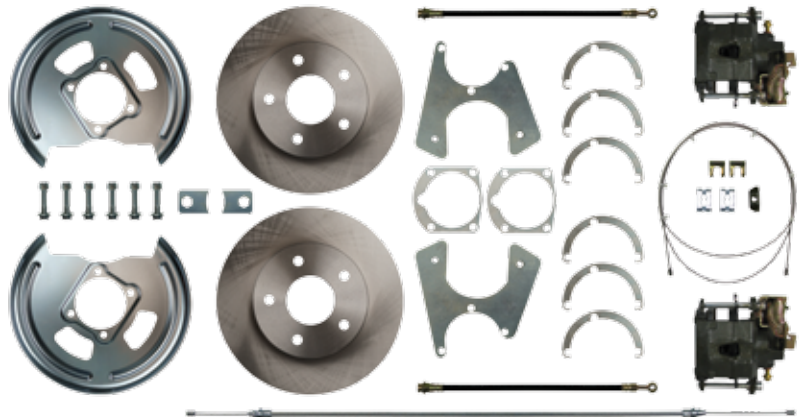

AT-THE-WHEEL REAR KIT

6-3/16" INSIDE ROTOR DIAMETER - 2.78" CENTER HOLE

Packages include At-the-Wheel Disc Conversion Kits & Master Cylinder with Valve (Manual) or Master Cylinder with Booster and Valve (Power).

STOCK HEIGHT 4-WHEEL KITS

FSC554SDC...55-57... Manual Disc Brake Conversion Package
FSC554DCC...55-57... Power Disc Brake Conversion Package

2" DROP 4-WHEEL KITS

FSC554SDD...55-57... 2" Drop Manual Disc Brake Conv Package
FSC554DCD...55-57... 2" Drop Power Disc Brake Conv Package

UPGRADES The next page offers upgrades to fully customize your conversion kit.



1955-57 CHEVY 4-WHEEL BRAKE UPGRADES

4-WHEEL DISC BRAKE CONVERSION UPGRADES **STREET SERIES**

SHOW'N GO UPGRADE TRIM KITS

These At-the-Wheel Disc Conversion Kits (stock height or 2" drop) include upgraded drilled slotted rotors with zinc plating, powder coated calipers in red or black, and braided stainless hoses.



STOCK HEIGHT SHOW'N GO

FSC554SDCS... 55-57... Manual Disc Conversion Package - Black
 FSC554SDCZ... 55-57... Manual Disc Conversion Package - Red
 FSC554DCCS... 55-57... Power Disc Conversion Pkg - 9" Booster - Black
 FSC554DCCZ... 55-57... Power Disc Conversion Pkg - 9" Booster - Red

2" DROP SHOW'N GO

FSC554SDDS... 55-57... 2" Drop - Manual Disc Conversion Pkg - Black
 FSC554SDDZ... 55-57... 2" Drop - Manual Disc Conversion Pkg - Red
 FSC554DCDS... 55-57... 2" Drop - Pwrr Disc Conv Pkg - 9" Booster - Black
 FSC554DCDZ... 55-57... 2" Drop - Pwrr Disc Conv Pkg - 9" Booster - Red

SHOW STOPPER TRIM PACKAGES

Includes At-the-Wheel Front Disc Conversion Kit (stock height or 2" drop) with natural finish calipers. The Manual Packages get an upgraded chrome plated master cylinder and combination valve with bracket. Power Packages include an upgraded 8" dual chrome booster.

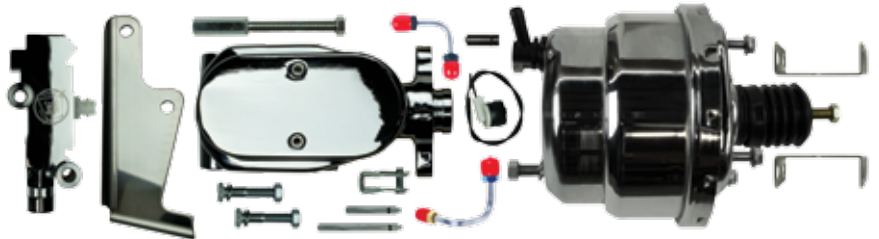

STOCK HEIGHT SHOW STOPPER

FSC554SDCX... 55-57 ... Manual Disc Brake Conversion Package
 FSC554DCCX... 55-57 ... Power Disc Brake Conversion Package

2" DROP SHOW STOPPER

FSC554SDDX... 55-57 ... 2" Drop Manual Disc Brake Conv Pkg
 FSC554DCDX... 55-57 ... 2" Drop Power Disc Brake Conv Pkg

BEST OF SHOW TRIM PACKAGES

Includes At-the-Wheel Front Disc Conversion Kit (stock height or 2" drop) with black or red calipers, drilled & slotted rotors & braided stainless hoses. The Manual Packages get an upgraded chrome plated master cylinder and combination valve with bracket. Power Packages include an upgraded 8" dual chrome booster.



STOCK HEIGHT BEST OF SHOW

FSC554SDCSX... 55-57 ... Manual Disc Brake Conv Package - Black
 FSC554SDCZX... 55-57 ... Manual Disc Brake Conv Package - Red
 FSC554DCCSX... 55-57 ... Power Disc Brake Conv Package - Black
 FSC554DCCZX... 55-57 ... Power Disc Brake Conv Package - Red

2" DROP BEST OF SHOW

FSC554SDDSX... 55-57 ... 2" Drop Manual Disc Brake Conv Pkg - Blk
 FSC554SDDZX... 55-57 ... 2" Drop Manual Disc Brake Conv Pkg - Red
 FSC554DCDSX... 55-57 ... 2" Drop Power Disc Brake Conv Pkg - Blk
 FSC554DCDZX... 55-57 ... 2" Drop Power Disc Brake Conv Pkg - Red



Disc Brake Conversions require special brake lines that fit your new disc conversion setup. Right Stuff offers "No Brainer" Brake Line Kits that include all components needed from your master cylinder back to your rear wheel cylinder or calipers. They include front brake line kit, front to rear line, rear axle lines & flex hose, & clip set.

See page 99 for your application

1955-57 CHEVY REAR BRAKE CONVERSIONS

**STREET
SERIES**

REAR DISC BRAKE CONVERSION KITS

REAR CONVERSIONS INCLUDE:

- 11" Rotors
- Caliper Brackets & Spacers
- Weld-On Hose Brackets
- Flex Hoses
- Backing Plates (Exclusive)
- New Loaded Caliper
- E-Brake Cables
- Hardware

NOTE:

FITS FACTORY
REAR ENDS
CALL FOR CUSTOM
APPLICATIONS

Right Stuff disc conversions are the most complete kits in the industry at the right price. High quality components, professional packaging, and after-sale support by "hands-on" technicians create an unbeatable value. Consider one of our complete brake line packages for a carefree installation. See page 98 to verify axle flange measurements for these kits.

WANT MATCHING FRONT UPGRADES?

SEE BELOW FOR OUR REAR+2 CONVERSIONS

WORKS WITH 15" AND LARGER WHEELS

6 3/16" INSIDE ROTOR DIAMETER - 2.78" CENTER HOLE

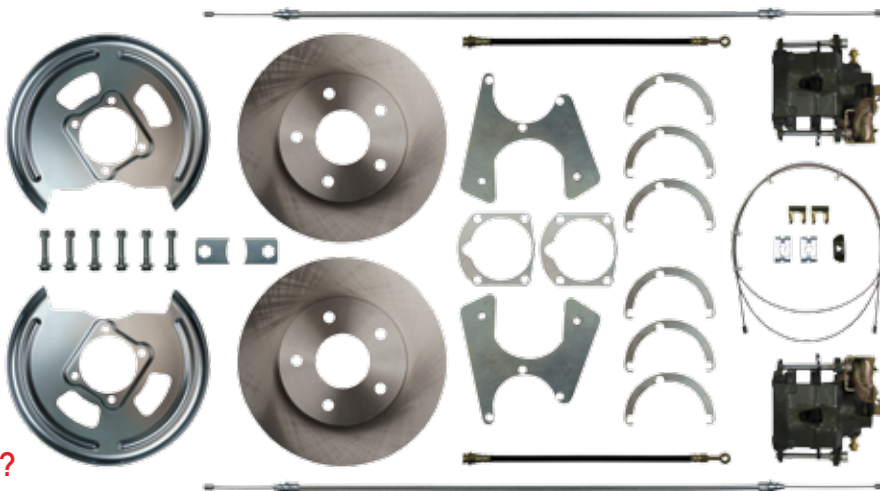

KITS WITH E-BRAKE

FSCRD01 55-57Factory Rear with Drop Out Axles

KITS WITHOUT E-BRAKE

FSCRDM1 55-57Factory Rear with Drop Out Axles

ATTENTION Before you order, be sure to measure the axle flange on your vehicle.

REAR DISC BRAKE CONVERSION UPGRADES

**STREET
SERIES**

SHOW'N GO UPGRADE TRIM PACKAGES

These packages add drilled slotted rotors with zinc plating, powder coated calipers in red or black, and braided stainless hoses. Just add an "S" for black calipers or a "Z" for red calipers to the end of your conversion part number.



REAR UPGRADE WITH E-BRAKE

FSCRD01S 55-57Factory Rear with Drop Out Axles - Black

FSCRD01Z 55-57Factory Rear with Drop Out Axles - Red

REAR UPGRADE W/O E-BRAKE

FSCRDM1S ... 55-57Factory Rear with Drop Out Axles - Black

FSCRDM1Z ... 55-57Factory Rear with Drop Out Axles - Red



1955-57 CHEVY EZ FIT STOCK STYLE CONVERSIONS



BRAKE•KITS

Fits stock 14" wheel. Bolts to stock drum or disc brake spindles. Minimal offset for better fenderwell clearance. Proprietary rotor.

EZ FIT BRAKE CONVERSION KITS

HALF THE INSTALL TIME

**KEEP YOUR FACTORY
14" WHEELS**

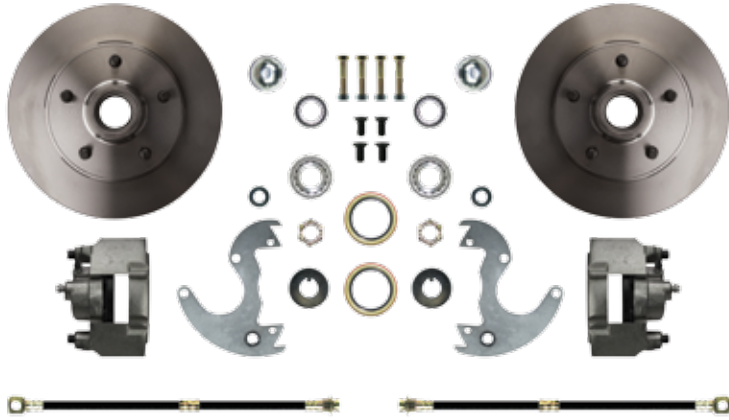

AT-THE-WHEEL KIT

Packages include At-the-Wheel Disc Conversion Kits & Master Cylinder with Valve (Manual) or Master Cylinder with Booster and Valve (Power).

EZ FIT FRONT CONVERSIONS INCLUDE:

- 10" Rotors with Organic Pads
- New Calipers & Brackets
- Banjo Bolts & Copper Washers
- Dust Caps, Castle Nuts & Pins
- Brake Switch Pigtail
- Master Cylinder (Power/Manual Kits)
- Timken Bearings
- Flex Hoses & Kit
- Grease Seals
- Steering Arm Bolts
- Combination Valve
- 9" Booster (Power)

EZ FIT REAR CONVERSIONS INCLUDE:

- Fits 14" wheels
- Uses proprietary rotor
- Built in e-brake (No cables included)

Bolts to your stock drum or disc brake spindles.



POWER PACKAGE



MANUAL PACKAGE

FRONT 14" - STANDARD ROTORS

FSC5514P55-57..... Front Power Disc Conversion Package
 FSC5514S55-57..... Front Manual Disc Conversion Package

REAR 14" - STANDARD ROTORS

FSCRD1455-57..... Rear Kit, Non-Staggered

**LOOKING FOR A DIFFERENT
BOOSTER + MASTER
CYLINDER IN YOUR KIT?**

Simply purchase an At-The-Wheel Kit above along with any Booster + Master combo on page 87.



1955-57 CHEVY PERFORMANCE SERIES CONVERSIONS



COMPLETE DISC BRAKE CONVERSION KITS



U.S.A. Made
TIMKEN Bearings

Right Stuff Performance Series disc conversions are the most complete kits in the industry at the right price. Designed for the performance street machine with high quality components, professional packaging, and after-sale support by "hands-on" technicians and many DIY videos at rightstuff creates an unbeatable value.

Kits are available as an **At-The-Wheel Kit** that includes everything for a front disc brake conversion, and as a **Complete Conversion Kit** which includes everything in the At-The-Wheel Kit with the addition of the master cylinder, booster and prop valve (Power or Manual).



FSC56WKCS
FRONT AT-THE-WHEEL KITS

WORKS WITH 15" AND LARGER WHEELS

AT-THE-WHEEL CONVERSION KITS INCLUDE:

- 11" Drilled & Slotted Rotors
- Wilwood Dual Piston Calipers
- Caliper Brackets
- Backing Plates
- Timken Bearings
- Castle Nuts & Pins
- Dust Caps
- Spindles
- Organic Pads
- Washers
- Grease Seals
- Spindle Gaskets
- Steering Arm Bolts
- Hardware

COMPLETE CONVERSION KITS ALSO INCLUDE

- Master Cylinder - Chrome or Standard Finish
- Flex Hoses & Clips
- Valve Bracket & Hardware
- Banjo Bolts & Copper Washers
- Combination Valve
- Brake Switch Pigtail
- Pedal Rod Extension

Kits have an offset of 3/8" per side. For zero offset kit option, see pg 97.

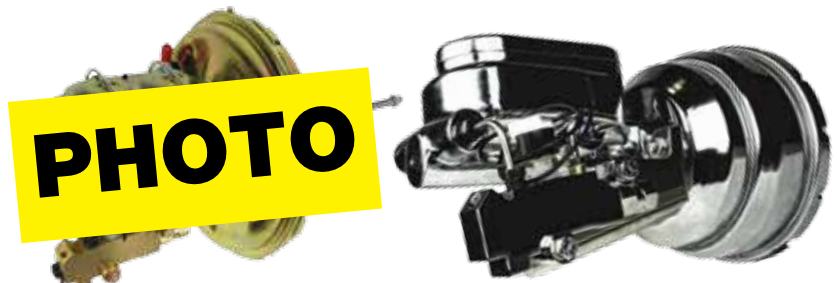

PHOTO

STANDARD PACKAGE

CHROME PACKAGE

STOCK HEIGHT FRONT KITS

- FSC56DCCS 55-57 ...Standard Booster/Master - Black Wilwood
- FSC56DCCZ 55-57 ...Standard Booster/Master - Red Wilwood
- FSC56DCCSX .. 55-57 ...Chrome Booster/Master - Black Wilwood
- FSC56DCCSX .. 55-57 ...Chrome Booster/Master - Red Wilwood

AT-THE-WHEEL FRONT DISC KITS

- FSC56WKCS ... 55-57 ...Stock Height - Black Wilwood
- FSC56WKZC ... 55-57 ...Stock Height - Red Wilwood

AXLE FLANGE DIAGRAMS

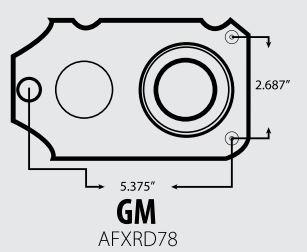
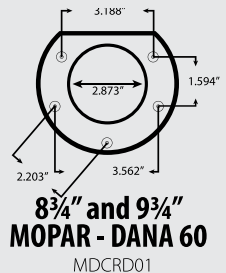
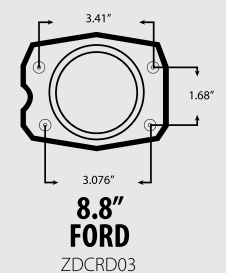
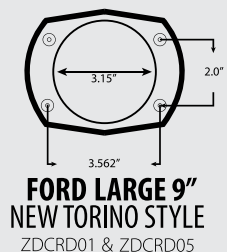
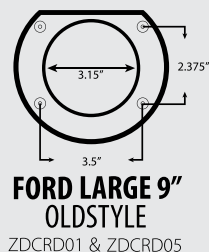
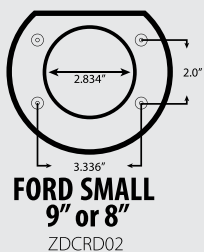
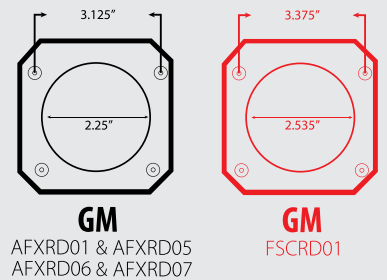
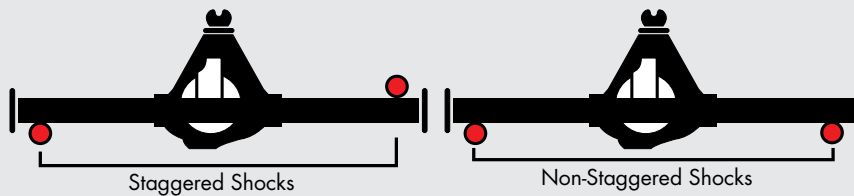



No Brainer BRAKE LINE KITS

DESIGNED FOR DISC CONVERSIONS

When you add disc brakes to your car you are using a new valve that has different size ports pointing in different directions. Even if your lines are brand new or great originals, you are going to have issues trying to use them. Our No Brainer Brake Line Kit fixes all these issues from your master cylinder all the way back to your rear wheel cylinders or rear calipers. We give you all the lines to complete the installation. We also include the rear flex hose and a full clip set to install your lines. Extremely discounted prices and great instructions make this kit a No Brainer.

SIMPLIFY YOUR DISC BRAKE CONVERSION INSTALLATION WITH ALL OF THE BRAKE LINES YOU WILL NEED.

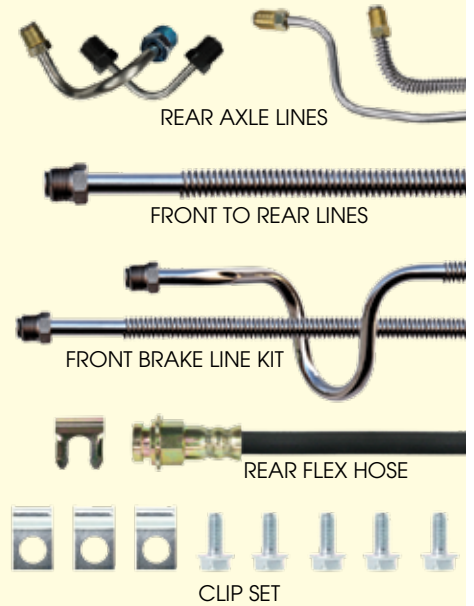

MANUAL - NO VACUUM BOOSTER

FRONT DISC/REAR DRUM LINES

BOM55H2.....55-57..... OE Steel Brake Line Kit
BSM55H2.....55-57..... Stainless Steel Brake Line Kit

4-WHEEL DISC LINES

BOM55H4.....55-57..... OE Steel Brake Line Kit
BSM55H4.....55-57..... Stainless Steel Brake Line Kit

POWER - WITH VACUUM BOOSTER

FRONT DISC/REAR DRUM LINES

BOP55H2.....55-57..... OE Steel Brake Line Kit
BSP55H2.....55-57..... Stainless Steel Brake Line Kit

4-WHEEL DISC LINES

BOP55H4.....55-57..... OE Steel Brake Line Kit
BSP55H4.....55-57..... Stainless Steel Brake Line Kit

PROPORTIONING VALVES

DOES YOUR VALVE LOOK LIKE THIS?

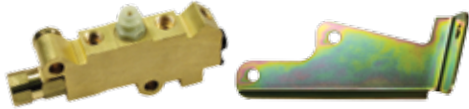

When upgrading to disc brakes or keeping them stock, make sure your proportioning valve is designed for the brake system that is specific to your vehicle.



PVK71..... Disc/Drum Proportioning Valve - Brass Finish
PVK72..... Disc/Disc Proportioning Valve - Brass Finish
PVK71C..... Disc/Drum Proportioning Valve - Chrome Finish
PVK72C..... Disc/Disc Proportioning Valve - Chrome Finish



1958-64 CHEVY BRAKE LINES

FRONT BRAKE LINE KITS

Front brake line kits consist of all brake lines under the hood. This includes the master cylinder to the distribution, combination or metering valve. The left and right front lines that run to the front flex hoses are also included. Call for individual component pricing. These line kits are for vehicles with factory brake systems.

ADD "S" TO PART NUMBER FOR STAINLESS STEEL

BKT5801 58 Standard Brakes 4 Pcs
BKT5802 58 Power Brakes 4 Pcs
BKT5901 59-61 Standard Brakes 4 Pcs
BKT5902 59-61 Power Brakes 4 Pcs
CKT5901 60-61 El Camino, Manual Brakes 4 Pcs
CKT5905 60-61 El Camino, Power Brakes 4 Pcs
BKT6201 62-64 Standard Brakes 4 Pcs
BKT6202 62-64 Power Brakes 4 Pcs
BKT6603 66 Biscayne, Standard Drum 5 Pcs

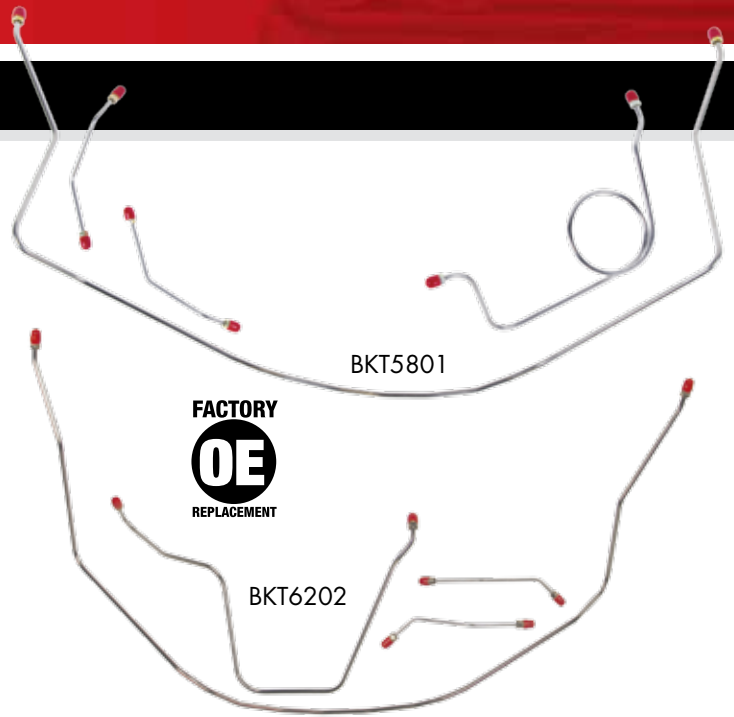

REAR AXLE BRAKE LINES

Rear axle brake lines include a pair of lines that run across the rear axle housing. These lines connect the wheel cylinders or calipers to the flex hose in the middle of the rear end. These lines work with original housings that use factory brakes. Modifications such as rear disc brakes or narrowed rear ends will likely require special lines. Call for more information.

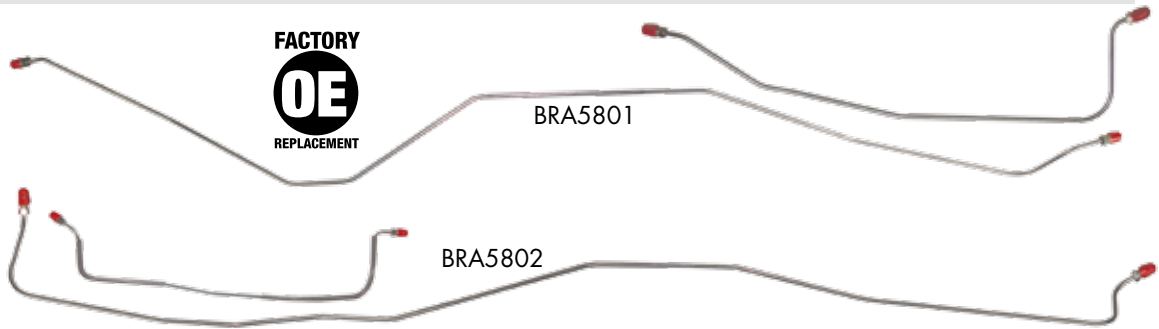

ADD "S" TO PART NUMBER FOR STAINLESS STEEL

BRA5801 58 All Cars
BRA5901 59-64 All Cars

FRONT TO REAR BRAKE LINES

Front to rear brake lines go from the distribution, combination or metering valve along the length of the vehicle to the rear flex hose. Lines are manufactured in 1 or 2 pieces based on factory specifications.

ADD "S" TO PART NUMBER FOR STAINLESS STEEL

BIN5801 58 All Cars
BIN5901 59-64 All Cars
CIN60EC 60 El Camino

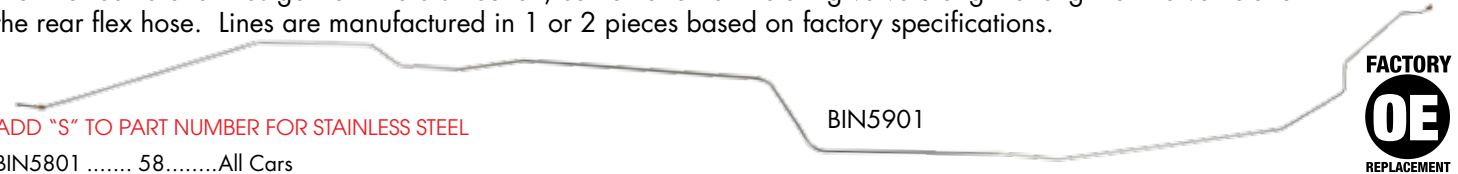

HOSE HARDWARE

Hose hardware is used to secure flex hoses to various parts of the vehicle. Front brackets are sold in pairs.



RSBB08



FHC01

RSBB08 58-64 Rear Hose Brass 'T' Block with Slot
FHC01 Correct Gold Cadmium Plated C Clips



1958-64 CHEVY BRAKE COMPONENTS

FRONT FLEX HOSES

Front flex hoses provide a flexible connection from the body or frame to the front calipers or wheel cylinders as they move during suspension travel. Choose between O.E. rubber or braided stainless steel. All of our hoses are D.O.T. approved. Hoses are priced individually.



FH45S

ADD "S" TO PART NUMBER FOR STAINLESS STEEL

FH45..... 58-66 ... Front Drum

REAR FLEX HOSES

Rear flex hoses carry brake fluid between the body of the car and the rear. Hoses are available in O.E. rubber and braided stainless steel. 'T' blocks are attached whenever factory correct. All of our hoses are D.O.T. approved. Prices are per hose.



FH33

ADD "S" TO PART NUMBER FOR STAINLESS STEEL

FH47..... 58-62..... Rear, All

FH33..... 63 with 14-1/2" Rear Hose

FH34..... 63 with 15-5/8" Rear Hose

FH33..... 64 Rear, All

WHEEL CYLINDERS



WC13

WC14

WC114

WC12

Wheel cylinders are priced individually. Hardware is not included.

WC113..... 58..... Left Front

WC114..... 58..... Right Front

WC11..... 58-64..... Left Rear

WC12..... 58-64..... Right Rear

WC13..... 59..... Left Front

WC14..... 59..... Right Front

WC15..... 60-64..... Left Front

WC16..... 60-64..... Right Front

BRAKE DRUMS

Brake drums are sold individually.

BD14



BD14 58..... Front or Rear Drum, Non-Finned

MASTER CYLINDERS

Most master cylinders are completely new units with no core charge. A deep cylinder pocket with a removable plug provides compatibility with manual brakes as well as power-assisted applications.



DBMC51C



DBMC09



DBMC09



DBMC51C

DBMC09 55-64 Power Disc, 1-1/8" Bore, Deep Pocket

DBMC01 55-64 Power Disc, 1-1/8" Bore, Shallow Pocket

DBMC05 55-64 1" Bore, Deep Pocket

DBMC09C 55-64 1-1/8" Bore, Chrome

DBMC05C 55-64 1" Bore, Chrome

DBMC51C 55-64 1-1/8" Bore, Slimline Flat Top, Chrome

DBMC56C 55-64 1" Bore, Slimline Flat Top, Chrome

VALVES & BLOCKS

We offer a full line of metering blocks, proportioning valves, distribution blocks and combination valves for factory drum and disc brake applications.



PV71



PV72



PV71C



PV01

PV01 58-64 Adjustable Valve

PV71 58-64 Disc/Drum Combination Valve, Brass

PV71C 58-64 Disc/Drum Combination Valve, Chrome

PV72 58-64 Disc/Disc Combination Valve, Brass

PV72C 58-64 Disc/Disc Combination Valve, Chrome

BRAKE VALVE BRACKETS

These brackets are used to mount various types of valves. Note that many of the valves we sell come with the mounting bracket. See individual valve listings for details.



PVB71



PVB71S

PVB71 Side Mount Bracket

PVB71S Side Mount Bracket, Polished Stainless

1958-64 CHEVY BRAKE COMPONENTS

SLIMLINE BOOSTER MASTER COMBOS

J81315672

The slimline combos offer clean lines and plenty of power in a small package. The 8" dual is our favorite. Mounting brackets included.



J81315672 TOP VIEW

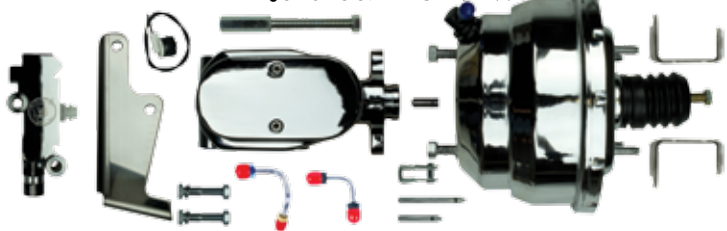

- G82310971 58 Gold 8" Dual, Disc/Drum
- J82315171 58 Chrome 8" Dual Disc/Drum
- G82310572 58 Gold 8" Dual, Disc/Disc
- J82315672 58 Chrome 8" Dual Disc/Disc
- G92020971 58 Gold 9" Single, Disc/Drum
- G84310971 59-64 Gold 8" Dual, Disc/Drum
- J84315171 59-64 Chrome 8" Dual Disc/Drum
- G84310572 59-64 Gold 8" Dual, Disc/Disc
- J84315672 59-64 Chrome 8" Dual Disc/Disc
- G94020971 59-64 Gold 9" Single, Disc/Drum

DELCO BOOSTER MASTER COMBOS

These combos have a factory looking appearance. Can be tight on big block cars. Mounting brackets included.



G92210971 TOP VIEW

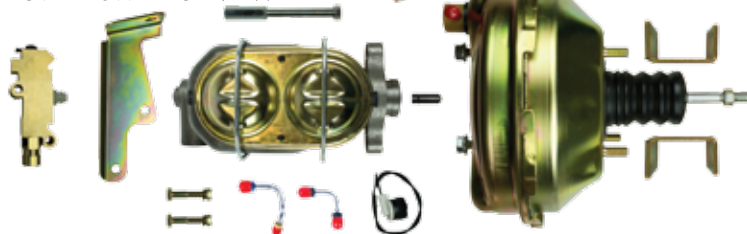

- G92210971 58 Gold 9" Single Disc/Drum
- J92215171 58 Chrome 9" Single, Disc/Drum
- G92210572 58 Gold 9" Single Disc/Disc
- J92215672 58 Chrome 9" Single, Disc/Disc
- G94210971 59-64 Gold 9" Single Disc/Drum
- J94215171 59-64 Chrome 9" Single, Disc/Drum
- G94210572 59-64 Gold 9" Single Disc/Disc
- J94215672 59-64 Chrome 9" Single, Disc/Disc

SLIMLINE BOOSTERS

Slimline boosters pack a lot of punch in a small, sleek package. Dual diaphragm versions provide 25% - 35% more assist than their single diaphragm equivalent. The 8" dual is our most popular for clearing big blocks while providing plenty of assist for two or four wheel disc brake systems. Mounting brackets included.



RPB7137



RPB7137C



RPB8131



RPB8131C

- RPB7237 58 7" Dual, Gold
- RPB7237C 58 7" Dual, Chrome
- RPB7237S 58 7" Dual, Stainless
- RPB8231 58 8" Dual, Gold
- RPB8231C 58 8" Dual, Chrome
- RPB8231S 58 8" Dual, Stainless
- RPB9202 58 9" Single, Gold
- RPB7437 59-64 7" Dual, Gold
- RPB7437C 59-64 7" Dual, Chrome
- RPB7437S 59-64 7" Dual, Stainless
- RPB8431 59-64 8" Dual, Gold
- RPB8431C 59-64 8" Dual, Chrome
- RPB8431S 59-64 8" Dual, Stainless
- RPB9402 59-64 9" Single, Gold

DELCO BOOSTERS

Reproductions based on original factory units. Mounting brackets included.

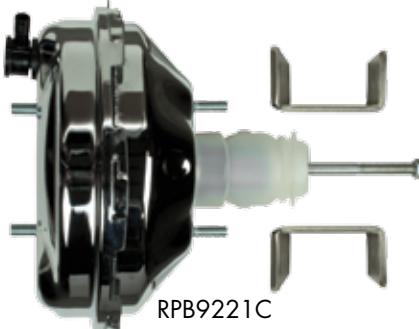

RPB9221C



RPB9221

- RPB9221 58 9" Single, Gold
- RPB9221C 58 9" Single, Chrome
- RPB9421 59-64 9" Single, Gold
- RPB9421C 59-64 9" Single, Chrome

1958-64 CHEVY BRAKE & FUEL COMPONENTS

E-BRAKE CABLES

Parking brake cable sets contain all the individual cables and hardware needed to restore the system. Front, rear, and intermediate cables are also sold individually. While supplies last. Sold in O.E. mild steel and stainless steel. These cables are for rear drum vehicles. If you have a rear disc conversion, call for available options.

• Complete Cable Kits

RSBCB04 58-64 All Cars
RSBCB04S 58-64 All Cars - Stainless

• Front Brake Cables

EBC7037 62-64 All Cars
EBC7037S 62-64 All Cars - Stainless

• Intermediate Brake Cables

EBC8022 62-64 All Cars
EBC8022S 62-64 All Cars - Stainless

• Rear Brake Cables

EBC9042 62-64 All Cars
EBC9042S 62-64 All Cars - Stainless

• E-Brake Hardware

EBH1004 58-64 Self Tapper
EBH3002 58-64 Center to Rear Silver Connector
RSCLP31 58-64 1/2' R Clip - Silver Zinc
EBH1007 58-64 Black Cable Clip

BOOSTER BRACKET



BBK006

BBK006 58-64 High Rise Booster Bracket

THERMAL CHOKE LINES

Thermal choke lines carry heat from the exhaust system to the choke coil on the carburetor. Some applications route thru the intake manifold on their way to the carburetor.

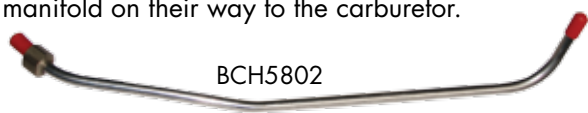

BCH5802

ADD "S" TO PART NUMBER FOR STAINLESS STEEL

BCH5801 58 348, 3x2 Carburetors
BCH5802 58 283, 2 BBL
BCH5803 58 283, 4 BBL
BCH5861 58-61 8 Cyl, 348, 4 BBL
BCH5701 58-70 6 Cyl, 235

FUEL PUMP TO CARB LINES

Fuel pump to carburetor lines connect the fuel pump to the carburetor. Brass blocks and fittings are included as noted. These lines are intended to work only with factory pump, motor, intake and carburetor combinations.

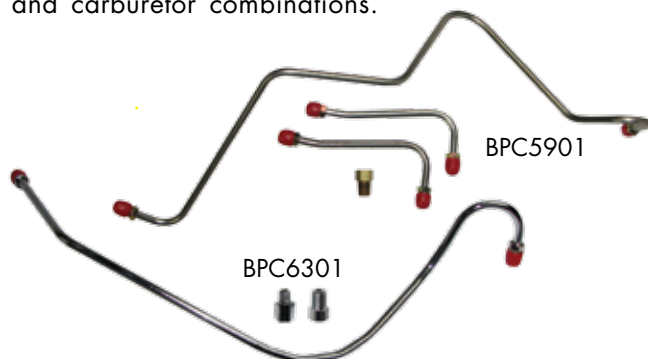

ADD "S" TO PART NUMBER FOR STAINLESS STEEL

BPC5801 58 348, 3x2's, 5 Lines, 6 Fittings
BPC5802 58 348 with Air Cond. & AFB, 4 BBL
BPC5803 58 348, 3x2 Vacuum 2nd Line Set
BPC5835 58 235, 6 Cylinder
BPC5804 58-61 ... 348, 4 BBL without AC
BPC5806 58-61 ... 348 with WFB, 4 BBL
BPC5935 59 235, 6 Cylinder
VPC5903 59 Power Pack, 327, 4 BBL
BPC5901 ... 59-61 ... 348, 3x2 Carbs., 3 Line Set
BPC5901F . 59-61 ... 4 Way Brass Adapter for BPC5901
BPC5903 ... 59-64 ... 283, 2 BBL
BPC6206 62 235, 6 Cylinder
BPC6201 ... 62-64 ... 327/250 HP, Carter Only
BPC6209 62 409, Dual 4 BBL, 2 Lines, 5 Fittings
BPC6202 ... 62-65 ... 327/300 HP with L-74 Option
BPC6301 ... 63-64 ... 409/340 HP, 5 Fittings - Chrome
BPC6302 ... 63-64 ... 409/340 HP, 1/4" Return - Chrome
BPC6304 ... 63-64 ... 409/400 HP, 2 Fittings - Chrome
BPC6305 ... 63-64 ... 409/400 HP, 1/4" Return - Chrome

AIR RIDE LINES

BAS5808 58 Complete Line Set - OE Steel
BAS5808S 58 Complete Line Set - Stainless



1958-64 CHEVY FUEL COMPONENTS

MAIN FUEL LINES

Main lines carry fuel from the tank in the rear of the car to the fuel pump or rail in the front. They are available in 3/8" and 5/16" tubing based on factory specifications. Multiple piece sets are noted. Call for 1/2" lines.

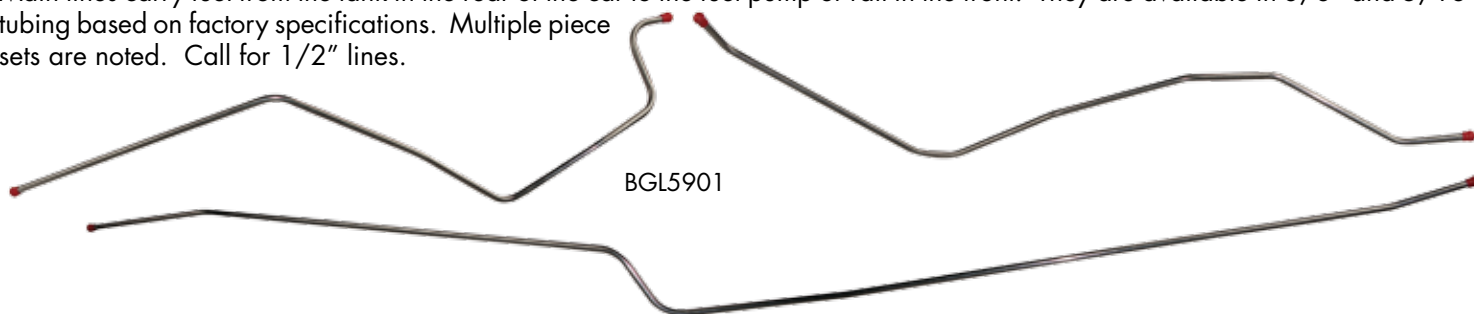

ADD "S" TO PART NUMBER FOR STAINLESS STEEL

BGL5801 58 3/8", Big Block, Under Rocker 3 Pcs.
 BGL5802 58 5/16", Small Block, Inside Frame
 BGL5902 59-61 5/16", Small Block
 BGL5901 59-62 3/8", Big Block 3 Pcs.
 BGL59EC 59 El Camino 3 Pcs.

BGL6202 62-64 5/16", Small Block
 BGL6232 62-64 3/8", Small Block
 BGL6203 62-64 Station Wagon
 BGL6301 63-64 3/8", SB/BB Engine, SS 3 Pcs.
 BGL6302 63-64 409 Wagon 3 Pcs.
 BGL6303 63-64 1/4", 409, Return Line

RETURN FUEL LINES

Return lines carry excess fuel from fuel pump or fuel filter back to the tank. Not all vehicles were equipped with a return line. They are typically made of 1/4" diameter tubing. Multiple piece sets are noted.

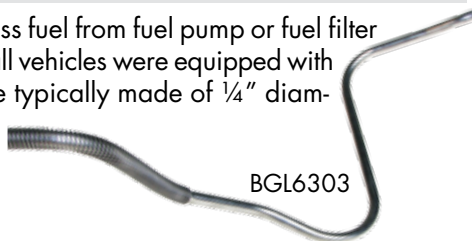

BGL6303 63-64 1/4", 409, Return Line - OE Steel
 BGL6303S 63-64 1/4", 409, Return Line - Stainless

FUEL HOSE KITS

These small rubber hoses and clips are used to connect fuel lines to the fuel pump and sending unit.



FHK3800 ALL 3/8" x 6", 3/8" x 13", + 4 Green Clamps
 FHK1438 ALL 3/8" x 6", 3/8" x 13", 1/4" x 18" + 4 Green Clamps and 4 Red Clamps

FUEL TANK VENT LINES

Fuel tank vent lines allow the air inside the fuel tank to escape as it is filled with fuel. They also prevent pressure from building up due to temperature changes.

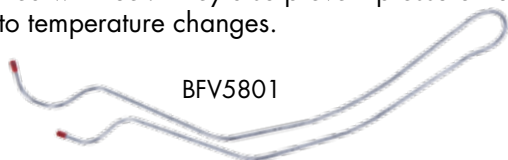

BFV5801 58 All Cars - OE Steel
 BFV5801S 58 All Cars - Stainless
 BFV5901 59 All Cars - OE Steel
 BFV5901S 59 All Cars - Stainless

FUEL TANKS

Fuel tanks are constructed of Ni-Terne steel. Hardware is not included.



BFT6104 FRONT & BACK VIEW



BFT5801 58 Chevy (Excludes Wagon)
 BFT5801S 58 Chevy (Excludes Wagon) - Stainless
 BFT5906 59-60 .. Chevy (Excludes Wagon)
 BFT5906S .. 59-60 .. Chevy (Excludes Wagon) - Stainless
 BFT6104 61-64 .. Chevy (Exc. Wagon) No Filler Neck
 BFT6104S .. 61-64 .. Chevy (Exc. Wagon) No Filler Neck - Stainless

FUEL SENDING UNITS

Sending units include floats, gaskets and snap rings where applicable. Our fuel senders are made of stainless steel and operate on the same ohm range as factory gauges.



BSU5801 58-60 5/16" Main Line
 BSU5802 58-60 3/8" Main Line
 BSU6101 61-64 5/16" Main Line
 BSU6102 61-64 3/8" Main Line

1958-64 CHEVY TRANSMISSION & SUSPENSION

TRANSMISSION COOLER LINES

Transmission cooler lines are sold as pairs. Be sure to verify the type of transmission in your project before ordering. These lines are intended to work only with factory motor, transmission, and radiator combinations.

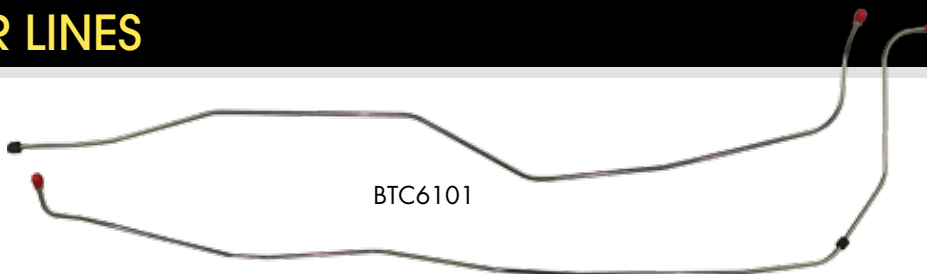

ADD "S" TO PART NUMBER FOR STAINLESS STEEL

BTC580158-60.... Iron Powerglide, 283, Std. Cooling
 BTC610359-61 348 with Turboglide, 3/8"
 BTC610161-64.... Alum. Powerglide, 327, Std. Cooling

TRANSMISSION VACUUM LINES

Transmission vacuum lines connect automatic transmissions to intake vacuum.



ADD "S" TO PART NUMBER FOR STAINLESS STEEL

CTV6401 64Powerglide
 CTV6402 646 Cylinder

DISTRIBUTOR VACUUM LINES

Distributor vacuum lines supply intake vacuum to the distributor for timing control.

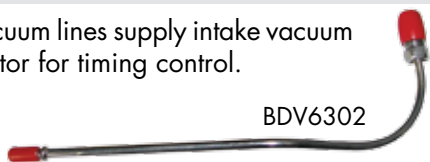

ADD "S" TO PART NUMBER FOR STAINLESS STEEL

BDV590359-64.....327/350HP
 BDV593559-64.....235,6Cylinder
 BDV630263-64.....409/340HP, Chrome

SUSPENSION PARTS

UPPER & LOWER BALL JOINTS

XK6035 58-64 Lower
 XK6034 58-64 Upper



UPPER & LOWER CONTROL ARM BUSHING KITS

XK5196 58-64 Upper, 2-Piece
 XK304 58-64 Lower, 4-Piece



INNER & OUTER TIE RODS & SLEEVES

XES59758-64.....Inner
 XES312RL58-62.....Outer
 XES312S58-62.....Adjusting Sleeve
 XES323L63-64.....Outer

SUSPENSION KITS

These prepackaged kits offer huge savings over individual suspension parts. Most kits include the following:

- Lower Ball Joints (2)
- Upper Ball Joints (2)
- Upper Ctrl. Arm Bushings (4)
- Outer Tie Ro (2)
- Lower Ctrl. Arm Bushings (4)
- Inner Tie Rods (2)



**COMING
IN 2017**

BSK5862

Standard rubber kits meet O.E. specifications. Polyurethane kits provide better handling & a firmer ride. Poly kits include upgraded control arm bushings, sway bar bushings & links.

BSK586258-62.. Suspension Rebuild Kit, 16 Ps.
 BSK5862U...58-62.. Suspension Rebuild Kit, 16 Ps. - Polyurethane
 BSK6364....63-64.. Front Rebuild Kit, 16-Piece, No Tie Rod Adjusting Sleeves
 BSK6364U..63-64.. Front Rebuild Kit, 16-Piece, No Tie Rod Adjusting Sleeves - Polyurethane

1958-64 CHEVY FRONT BRAKE CONVERSIONS

**STREET
SERIES**

FRONT DISC BRAKE CONVERSION KITS

U.S.A. Made
TIMKEN Bearings

FRONT CONVERSIONS INCLUDE:

- 11" Rotors
- Spindles (2" Drop Only)
- Timken Bearings
- New Calipers
- Caliper Brackets
- Organic Pads
- Backing Plates
- Flex Hoses & Clips
- Valve Bracket & Hardware
- Banjo Bolts & Copper Washers
- Dust Caps
- Castle Nuts & Pins
- Washers
- Grease Seals
- Spindle Gaskets
- Steering Arm Bolts
- Master Cylinder
- Combination Valve
- Pedal Rod Extension
- Brake Switch Pigtail

Kits have an offset of 3/8" per side. For zero offset kit option, see pg 111.

Right Stuff disc conversions are the most complete kits in the industry at the right price. High quality components, professional packaging, and after-sale support by "hands-on" technicians create an unbeatable value. Consider one of our complete brake line packages for a carefree installation.



Packages include At-the-Wheel Disc Conversion Kit & Master Cylinder with Valve (Manual) or Master Cylinder with Booster and Valve (Power).

POWER PACKAGE

MANUAL PACKAGE

11" inch booster, Call for other diameters

UPGRADES The next page offers upgrades to fully customize your conversion kit.



FITS 15" & LARGER WHEELS



AT-THE-WHEEL FRONT KITS

STOCK HEIGHT FRONT KITS

- FSC58WKC 58 At-the-Wheel Disc Conversion Kit
- FSC58SDC 58 Manual Disc Conversion Package
- FSC58DCC 58 Power Disc Conversion Package
- FSC59WKC 59-64 At-the-Wheel Disc Conversion Kit
- FSC59SDC 59-64 Manual Disc Conversion Package
- FSC59DCC 59-64 Power Disc Conversion Package

2" DROP FRONT KITS

- FSC58WKD 58 2" Drop At-the-Wheel Disc Conversion Kit
- FSC58SDD 58 2" Drop Manual Disc Conversion Package
- FSC58DCD 58 2" Drop Power Disc Conversion Package
- FSC59WKD .. 59-64 ... 2" Drop At-the-Wheel Disc Conversion Kit
- FSC59SDD 59-64 ... 2" Drop Manual Disc Conversion Package
- FSC59DCD ... 59-64 ... 2" Drop Power Disc Conversion Package



**No Brainer
BRAKE LINE KITS**
DESIGNED FOR DISC CONVERSIONS

Disc Brake Conversions require special brake lines that fit your new disc conversion setup. Right Stuff offers "No Brainer" Brake Line Kits that include all components needed from your master cylinder back to your rear wheel cylinder or calipers. They include front brake line kit, front to rear line, rear axle lines & flex hose, & clip set.

See page 113 for your application

1958-64 CHEVY FRONT BRAKE UPGRADES

FRONT DISC BRAKE CONVERSION UPGRADES

STREET SERIES

SHOW'N GO UPGRADE TRIM KITS

These At-the-Wheel Disc Conversion Kits (stock height or 2" drop) include upgraded drilled slotted rotors with zinc plating, powder coated calipers in red or black, and braided stainless hoses.

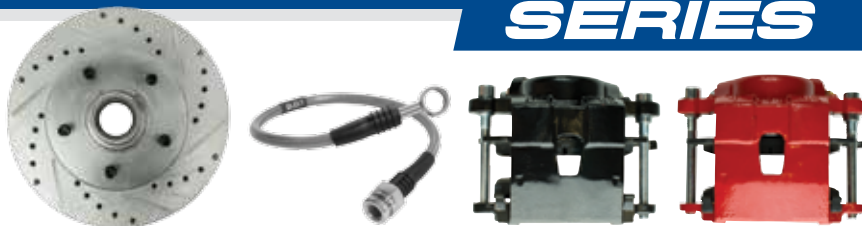

STOCK HEIGHT SHOW'N GO

FSC58WKCS 58 At-the-Wheel Disc Conversion Kit - Black
 FSC58WKCZ 58 At-the-Wheel Disc Conversion Kit - Red
 FSC58SDCS 58 Manual Disc Conversion Package - Black
 FSC58SDCZ 58 Manual Disc Conversion Package - Red
 FSC58DCCS 58 Power Disc Conv Pkg - 9" Booster - Black
 FSC58DCCZ 58 Power Disc Conv Pkg - 9" Booster - Red
 FSC59WKCS 59-64 At-the-Wheel Disc Conversion Kit - Black
 FSC59WKCZ 59-64 At-the-Wheel Disc Conversion Kit - Red
 FSC59SDCS 59-64 Manual Disc Conversion Package - Black
 FSC59SDCZ 59-64 Manual Disc Conversion Package - Red
 FSC59DCCS 59-64 Power Disc Conv Pkg - 9" Booster - Black
 FSC59DCCZ 59-64 Power Disc Conv Pkg - 9" Booster - Red

2" DROP SHOW'N GO

FSC58WKDS ...58 ...2" Drop At-the-Wheel Disc Conv Kit - Black
 FSC58WKDZ ...58 ...2" Drop At-the-Wheel Disc Conv Kit - Red
 FSC58SDDS 58 2" Drop - Manual Disc Conv Pkg - Black
 FSC58SDDZ 58 2" Drop - Manual Disc Conv Pkg - Red
 FSC58DCDS 58 2" Drop - Power Disc Conv Pkg - 9" Booster - Black
 FSC58DCDZ 58 2" Drop - Power Disc Conv Pkg - 9" Booster - Red
 FSC59WKDS ..59-64 ...2" Drop At-the-Wheel Disc Conv Kit - Black
 FSC59WKDZ ..59-64 ...2" Drop At-the-Wheel Disc Conv Kit - Red
 FSC59SDDS 59-64 2" Drop - Manual Disc Conv Pkg - Black
 FSC59SDDZ 59-64 2" Drop - Manual Disc Conv Pkg - Red
 FSC59DCDS ...59-64 ...2" Drop - Pwr Disc Conv Pkg - 9" Booster - Black
 FSC59DCDZ ...59-64 ...2" Drop - Pwr Disc Conv Pkg - 9" Booster - Red

SHOW STOPPER TRIM PACKAGES

Includes At-the-Wheel Front Disc Conversion Kit (stock height or 2" drop) with natural finish calipers. The Manual Packages get an upgraded chrome plated master cylinder and combination valve with bracket. Power Packages include an upgraded 8" dual chrome booster.

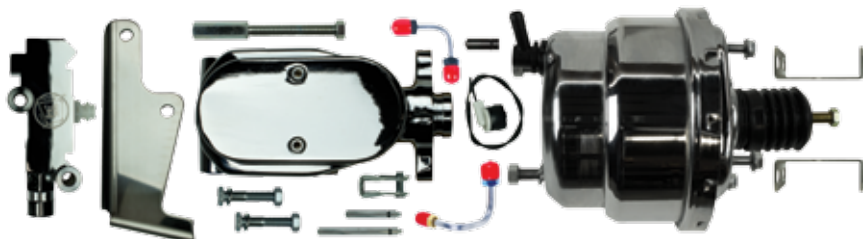

STOCK HEIGHT SHOW STOPPER

FSC58SDCX 58 Manual Disc Conversion Package
 FSC58DCCX 58 Power Disc Conversion Package
 FSC59SDCX 59-64 Manual Disc Conversion Package
 FSC59DCCX 59-64 Power Disc Conversion Package

2" DROP SHOW STOPPER

FSC58SDDX 58 2" Drop Manual Disc Conversion Package
 FSC58DCDX 58 2" Drop Power Disc Conversion Package
 FSC59SDDX 59-64 2" Drop Manual Disc Conversion Package
 FSC59DCDX 59-64 2" Drop Power Disc Conversion Package

BEST OF SHOW TRIM PACKAGES

Includes At-the-Wheel Front Disc Conversion Kit (stock height or 2" drop) with black or red calipers, drilled & slotted rotors & braided stainless hoses. The Manual Packages get an upgraded chrome plated master cylinder and combination valve with bracket. Power Packages include an upgraded 8" dual chrome booster.



STOCK HEIGHT BEST OF SHOW

FSC58SDCSX 58 Manual Disc Conversion Package - Black
 FSC58SDCZX 58 Manual Disc Conversion Package - Red
 FSC58DCCSX 58 Power Disc Conversion Package - Black
 FSC58DCCZX 58 Power Disc Conversion Package - Red
 FSC59SDCSX 59-64 Manual Disc Conversion Package - Black
 FSC59SDCZX 59-64 Manual Disc Conversion Package - Red
 FSC59DCCSX 59-64 Power Disc Conversion Package - Black
 FSC59DCCZX 59-64 Power Disc Conversion Package - Red

2" DROP BEST OF SHOW

FSC58SDDSX 58 2" Drop Manual Disc Conv Pkg - Black
 FSC58SDDZX 58 2" Drop Manual Disc Conv Pkg - Red
 FSC58DCDSX 58 2" Drop Power Disc Conv Pkg - Black
 FSC58DCDZX 58 2" Drop Power Disc Conv Pkg - Red
 FSC59SDDSX 59-64 2" Drop Manual Disc Conv Pkg - Black
 FSC59SDDZX 59-64 2" Drop Manual Disc Conv Pkg - Red
 FSC59DCDSX 59-64 2" Drop Power Disc Conv Pkg - Black
 FSC59DCDZX 59-64 2" Drop Power Disc Conv Pkg - Red

1958-64 CHEVY 4-WHEEL BRAKE CONVERSIONS

**STREET
SERIES**

FOUR WHEEL DISC BRAKE CONVERSION KITS

U.S.A. Made
TIMKEN Bearings

FOUR WHEEL CONVERSIONS INCLUDE:

- 11" Rotors
- Spindles (2" Drop Only)
- Timken Bearings
- New Calipers
- Caliper Brackets
- Organic Pads
- Backing Plates
- Flex Hoses & Clips
- Valve Bracket & Hardware
- Banjo Bolts & Copper Washers
- Rear Bracket Spacers
- Weld-On Hose Brackets
- Dust Caps
- Castle Nuts & Pins
- Washers
- Grease Seals
- Spindle Gaskets
- Steering Arm Bolts
- Master Cylinder
- Combination Valve
- Pedal Rod Extension
- Brake Switch Pigtail
- E-Brake Cables

Kits have an offset of 3/8" per side. For zero offset kit option, see pg 111.

Right Stuff disc conversions are the most complete kits in the industry at the right price. High quality components, professional packaging, and after-sale support by "hands-on" technicians create an unbeatable value. Consider one of our complete brake line packages for a carefree installation. See page 112 to verify axle flange measurements for these kits.



Packages include At-the-Wheel Disc Conversion Kits & Master Cylinder with Valve (Manual) or Master Cylinder with Booster and Valve (Power).

POWER PACKAGE

MANUAL PACKAGE

9" inch booster, Call for other diameters

STOCK HEIGHT 4-WHEEL KITS

- FSC584SDC..... 58 Manual Disc Brake Conversion Package
 FSC584DCC 58 Power Disc Brake Conversion Package
 FSC594SDC..... 59-64..... Manual Disc Brake Conversion Package
 FSC594DCC 59-64..... Power Disc Brake Conversion Package

WORKS WITH 15" AND LARGER WHEELS



AT-THE-WHEEL FRONT KIT

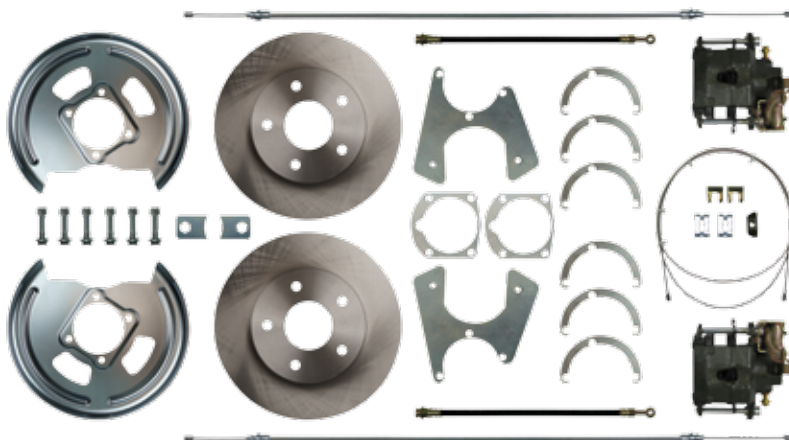

AT-THE-WHEEL REAR KIT

6-3/16" INSIDE ROTOR DIAMETER - 2.78" CENTER HOLE

2" DROP 4-WHEEL KITS

- FSC584SDD..... 58 2" Drop Manual Disc Brake Conv Package
 FSC584DCD 58 2" Drop Power Disc Brake Conv Package
 FSC594SDD..... 59-64... 2" Drop Manual Disc Brake Conv Package
 FSC594DCD ... 59-64... 2" Drop Power Disc Brake Conv Package

UPGRADES

The next page offers upgrades to fully customize your conversion kit.



**No Brainer
BRAKE LINE KITS**

DESIGNED FOR DISC CONVERSIONS

OE Steel Only

Stainless Steel

Disc Brake Conversions require special brake lines that fit your new disc conversion setup. Right Stuff offers "No Brainer" Brake Line Kits that include all components needed from your master cylinder back to your rear wheel cylinder or calipers. They include front brake line kit, front to rear line, rear axle lines & flex hose, & clip set.

See page 113 for your application

1958-64 CHEVY 4-WHEEL BRAKE UPGRADES

4-WHEEL DISC BRAKE CONVERSION UPGRADES **STREET SERIES**

SHOW'N GO UPGRADE TRIM KITS

These At-the-Wheel Disc Conversion Kits (stock height or 2" drop) include upgraded drilled slotted rotors with zinc plating, powder coated calipers in red or black, and braided stainless hoses.



STOCK HEIGHT SHOW'N GO

FSC584SDCS58 Manual Disc Conversion Package - Black
 FSC584SDCZ58 Manual Disc Conversion Package - Red
 FSC584DCCS.....58 Power Disc Conv Pkg - 9" Booster - Black
 FSC584DCCZ.....58 Power Disc Conv Pkg - 9" Booster - Red
 FSC594SDCS ...59-64... Manual Disc Conversion Package - Black
 FSC594SDCZ ...59-64... Manual Disc Conversion Package - Red
 FSC594DCCS...59-64... Power Disc Conv Pkg - 9" Booster - Black
 FSC594DCCZ...59-64... Power Disc Conv Pkg - 9" Booster - Red

2" DROP SHOW'N GO

FSC584SDDS 582" Drop - Manual Disc Conversion Pkg - Black
 FSC584SDDZ 582" Drop - Manual Disc Conversion Pkg - Red
 FSC584DCDS.... 582" Drop - Power Disc Conv Pkg - 9" Booster - Blk
 FSC584DCDZ.... 582" Drop - Power Disc Conv Pkg - 9" Booster - Red
 FSC594SDDS ..59-64..2" Drop - Manual Disc Conversion Pkg - Black
 FSC594SDDZ ..59-64..2" Drop - Manual Disc Conversion Pkg - Red
 FSC594DCDS..59-64..2" Drop - Power Disc Conv Pkg - 9" Booster - Blk
 FSC594DCDZ..59-64..2" Drop - Power Disc Conv Pkg - 9" Booster - Red

SHOW STOPPER TRIM PACKAGES

Includes At-the-Wheel Front Disc Conversion Kit (stock height or 2" drop) with natural finish calipers. The Manual Packages get an upgraded chrome plated master cylinder and combination valve with bracket. Power Packages include an upgraded 8" dual chrome booster.

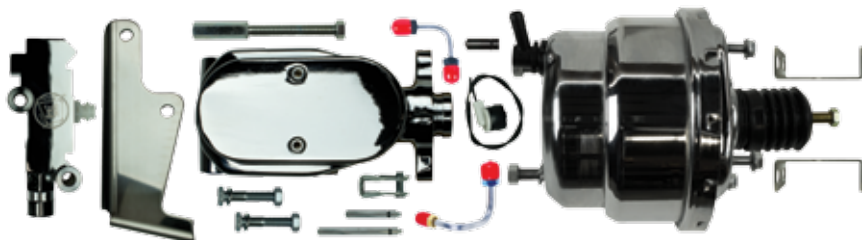

STOCK HEIGHT SHOW STOPPER

FSC584SDCX.....58 Manual Disc Brake Conversion Package
 FSC584DCCX58 Power Disc Brake Conversion Package
 FSC594SDCX.... 59-64 Manual Disc Brake Conversion Package
 FSC594DCCX ... 59-64 Power Disc Brake Conversion Package

2" DROP SHOW STOPPER

FSC584SDDX 58..... 2" Drop Manual Disc Brake Conv Package
 FSC584DCDX..... 58..... 2" Drop Power Disc Brake Conv Package
 FSC594SDDX 59-64 ... 2" Drop Manual Disc Brake Conv Package
 FSC594DCDX.... 59-64 ... 2" Drop Power Disc Brake Conv Package

BEST OF SHOW TRIM PACKAGES

Includes At-the-Wheel Front Disc Conversion Kit (stock height or 2" drop) with black or red calipers, drilled & slotted rotors & braided stainless hoses. The Manual Packages get an upgraded chrome plated master cylinder and combination valve with bracket. Power Packages include an upgraded 8" dual chrome booster.



STOCK HEIGHT BEST OF SHOW

FSC584SDCSX58 Manual Disc Brake Conv Package - Black
 FSC584SDCZX58 Manual Disc Brake Conv Package - Red
 FSC584DCCSX.....58 Power Disc Brake Conv Package - Black
 FSC584DCCZX.....58 Power Disc Brake Conv Package - Red
 FSC594SDCSX ... 59-64 ... Manual Disc Brake Conv Package - Black
 FSC594SDCZX ... 59-64 ... Manual Disc Brake Conv Package - Red
 FSC594DCCSX ... 59-64 ... Power Disc Brake Conv Package - Black
 FSC594DCCZX ... 59-64 ... Power Disc Brake Conv Package - Red

2" DROP BEST OF SHOW

FSC584SDDSX..... 582" Drop Manual Disc Brake Conv Pkg - Black
 FSC584SDDZX..... 582" Drop Manual Disc Brake Conv Pkg - Red
 FSC584DCDSX 582" Drop Power Disc Brake Conv Pkg - Black
 FSC584DCDZX 582" Drop Power Disc Brake Conv Pkg - Red
 FSC594SDDSX....59-64...2" Drop Manual Disc Brake Conv Pkg - Black
 FSC594SDDZX....59-64...2" Drop Manual Disc Brake Conv Pkg - Red
 FSC594DCDSX ..59-64...2" Drop Power Disc Brake Conv Pkg - Black
 FSC594DCDZX ..59-64...2" Drop Power Disc Brake Conv Pkg - Red

1958-64 CHEVY REAR BRAKE CONVERSIONS

**STREET
SERIES**

REAR DISC BRAKE CONVERSION KITS

U.S.A. Made
TIMKEN Bearings

REAR CONVERSIONS INCLUDE:

- 11" Rotors
- Caliper Brackets & Spacers
- Weld-On Hose Brackets
- Flex Hoses
- Backing Plates (Exclusive)
- New Loaded Caliper
- E-Brake Cables
- Hardware

NOTE:

FITS FACTORY
REAR ENDS
CALL FOR CUSTOM
APPLICATIONS

Right Stuff disc conversions are the most complete kits in the industry at the right price. High quality components, professional packaging, and after-sale support by "hands-on" technicians create an unbeatable value. Consider one of our complete brake line packages for a care-free installation. See page 112 to verify axle flange measurements for these kits.

WANT MATCHING FRONT UPGRADES?

SEE PAGE 111 FOR OUR REAR+2 CONVERSIONS

WORKS WITH 15" AND LARGER WHEELS

6 3/16" INSIDE ROTOR DIAMETER - 2.78" CENTER HOLE

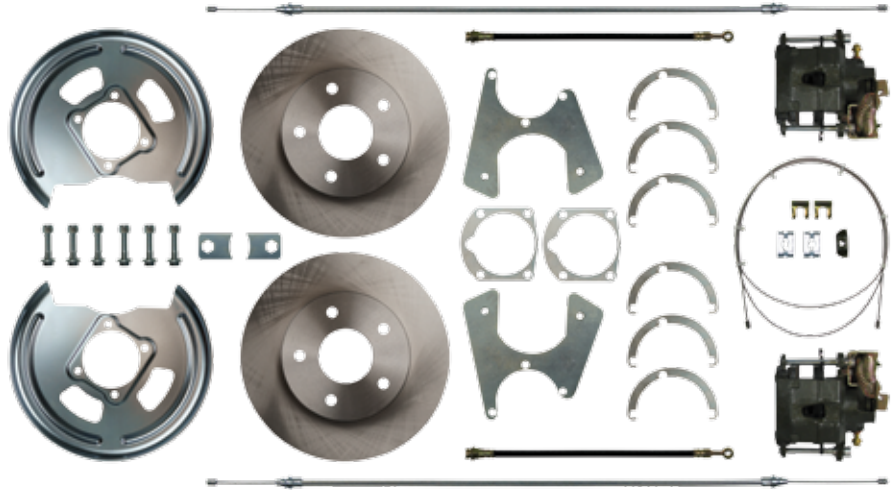

ATTENTION Before you order, be sure to measure the axle flange on your vehicle.

REAR KITS WITH E-BRAKE

FSCRD0158-64..... Factory Rear with Drop Out Axles

REAR KITS WITHOUT E-BRAKE

FSCRDM158-64..... Factory Rear with Drop Out Axles

REAR DISC BRAKE CONVERSION UPGRADES

**STREET
SERIES**

SHOW'N GO UPGRADE TRIM PACKAGES

These Rear Disc Conversion Kits (stock height or 2" drop) include upgraded drilled slotted rotors with zinc plating, powder coated calipers in red or black, and braided stainless hoses.



REAR UPGRADE WITH E-BRAKE

FSCRD01S58-64.... Factory Rear with Drop Out Axles - Black

FSCRD01Z58-64.... Factory Rear with Drop Out Axles - Red

REAR UPGRADE W/O E-BRAKE

FSCRDM1S58-64.... Factory Rear with Drop Out Axles - Black

FSCRDM1Z58-64.... Factory Rear with Drop Out Axles - Red

 **No Brainer
BRAKE LINE KITS**
DESIGNED FOR DISC CONVERSIONS

OE Steel Only

Stainless Steel

Disc Brake Conversions require special brake lines that fit your new disc conversion setup. Right Stuff offers "No Brainer" Brake Line Kits that include all components needed from your master cylinder back to your rear wheel cylinder or calipers. They include front brake line kit, front to rear line, rear axle lines & flex hose, & clip set.

See page 113 for your application

1958-64 CHEVY EZ FIT STOCK STYLE CONVERSIONS



BRAKE•KITS

EZ FIT BRAKE CONVERSION KITS

HALF THE INSTALL TIME

**KEEP YOUR FACTORY
14" WHEELS**

Fits stock 14" wheel. Bolts to stock drum or disc brake spindles. Minimal offset for better fenderwell clearance. Proprietary rotor.

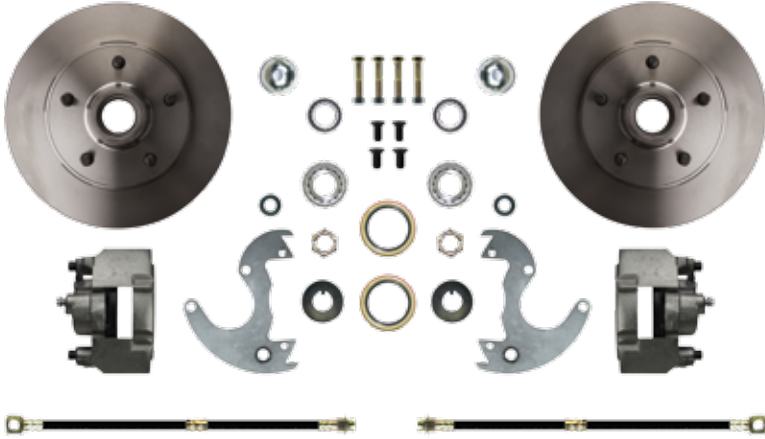

Packages include At-the-Wheel Disc Conversion Kits & Master Cylinder with Valve (Manual) or Master Cylinder with Booster and Valve (Power).

FRONT 14" - STANDARD ROTORS

FSC5814P 58-64Front Power Disc ConversionPackage
FSC5814S 58-64Front Manual Disc Conversion Package

EZ FIT FRONT CONVERSIONS INCLUDE:

- 10" Rotors with Organic Pads
- New Calipers & Brackets
- Banjo Bolts & Copper Washers
- Dust Caps, Castle Nuts & Pins
- Brake Switch Pigtail
- Master Cylinder (Power/Manual Kits)
- Timken Bearings
- Flex Hoses & Kit
- Grease Seals
- Steering Arm Bolts
- Combination Valve
- 9" Booster (Power)

EZ FIT REAR CONVERSIONS INCLUDE:

- Fits 14" wheels
- Uses proprietary rotor
- Built in e-brake (No cables included)

Bolts to your stock drum or disc brake spindles.



**POWER PACKAGE
From 761.25**

**MANUAL PACKAGE
From 677.25**

REAR 14" - STANDARD ROTORS

FSCRD14 58-64Rear Kit, Non-Staggered

**LOOKING FOR A DIFFERENT
BOOSTER + MASTER
CYLINDER IN YOUR KIT?**

Simply purchase an At-The-Wheel Kit above along with any Booster + Master combo on page 102.



1958-64 CHEVY PERFORMANCE SERIES CONVERSIONS



COMPLETE DISC BRAKE CONVERSION KITS



U.S.A. Made
TIMKEN Bearings

Right Stuff Performance Series disc conversions are the most complete kits in the industry at the right price. Designed for the performance street machine with high quality components, professional packaging, and after-sale support by "hands-on" technicians and many DIY videos at rightstuff create an unbeatable value.

Kits are available as an **At-The-Wheel Kit** that includes everything for a front disc brake conversion, & as a **Complete Conversion Kit** which includes everything in the At-The-Wheel Kit with the addition of the master cylinder, booster & prop valve (Power or Manual).

Kits have an offset of 3/8" per side. For zero offset kit option, see pg 111.

WORKS WITH 15" AND LARGER WHEELS

AT-THE-WHEEL CONVERSION KITS INCLUDE:

- 11" Drilled & Slotted Rotors
- Wilwood Dual Piston Calipers
- Caliper Brackets
- Backing Plates
- Timken Bearings
- Castle Nuts & Pins
- Dust Caps
- Spindles
- Organic Pads
- Washers
- Grease Seals
- Spindle Gaskets
- Steering Arm Bolts
- Hardware

COMPLETE CONVERSION KITS ALSO INCLUDE

- Master Cylinder - Chrome or Standard Finish
- Flex Hoses & Clips
- Valve Bracket & Hardware
- Banjo Bolts & Copper Washers
- Combination Valve
- Brake Switch Pigtail
- Pedal Rod Extension



FSC56WKCS

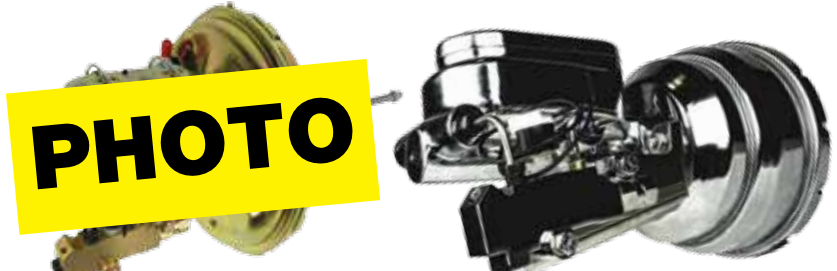

PHOTO

STANDARD FINISH

CHROME FINISH

STOCK HEIGHT FRONT KITS

- FSC56DCCS58-64... Standard Booster/Master - Black Wilwood
- FSC56DCCZ58-64... Standard Booster/Master - Red Wilwood
- FSC56DCCSX ...58-64... Chrome Booster/Master - Black Wilwood
- FSC56DCCSX ...58-64... Chrome Booster/Master - Red Wilwood

AT-THE-WHEEL FRONT DISC KITS

- FSC56WKCS58-64..... Stock Height - Black Wilwood
- FSC56WK CZ58-64..... Stock Height - Red Wilwood

AXLE FLANGE DIAGRAMS

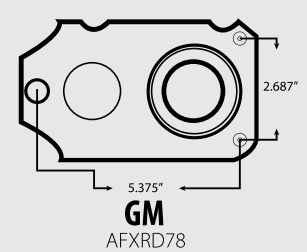
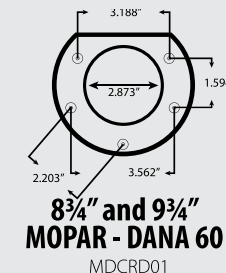
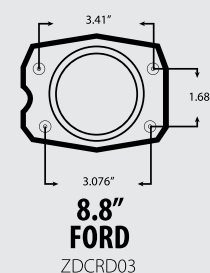
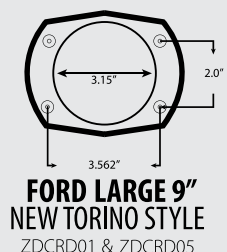
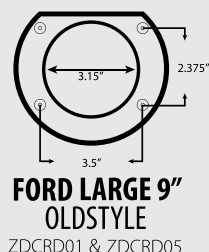
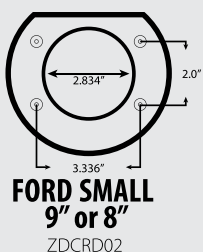
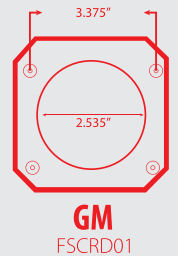
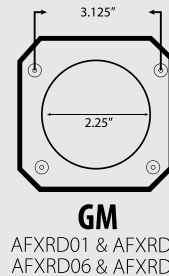
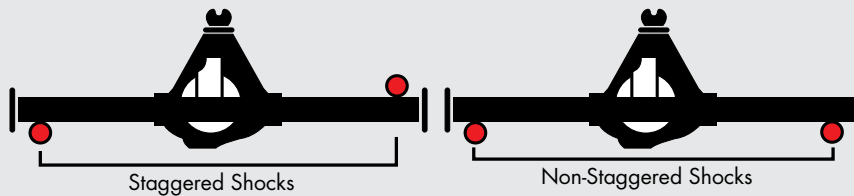



No Brainer BRAKE LINE KITS

DESIGNED FOR DISC CONVERSIONS

When you add disc brakes to your car you are using a new valve that has different size ports pointing in different directions. Even if your lines are brand new or great originals, you are going to have issues trying to use them. Our No Brainer Brake Line Kit fixes all these issues from your master cylinder all the way back to your rear wheel cylinders or rear calipers. We give you all the lines to complete the installation. We also include the rear flex hose and a full clip set to install your lines. Extremely discounted prices and great instructions make this kit a No Brainer.

SIMPLIFY YOUR DISC BRAKE CONVERSION INSTALLATION WITH ALL OF THE BRAKE LINES YOU WILL NEED.

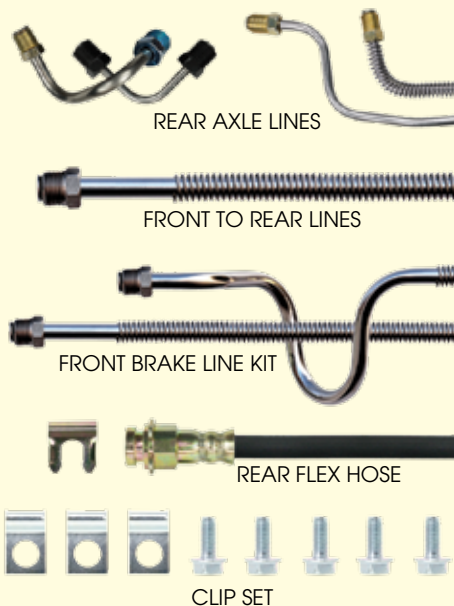

MANUAL - NO VACUUM BOOSTER

FRONT DISC/REAR DRUM LINES

BOM58H2.....1958..... OE Steel Brake Line Kit
 BSM58H2.....1958..... Stainless Steel Brake Line Kit
 BOM59H2..... 59-64 OE Steel Brake Line Kit
 BSM59H2..... 59-64 Stainless Steel Brake Line Kit

4-WHEEL DISC LINES

BOM58H4.....1958..... OE Steel Brake Line Kit
 BSM58H4.....1958..... Stainless Steel Brake Line Kit
 BOM59H4..... 59-64 OE Steel Brake Line Kit
 BSM59H4..... 59-64 Stainless Steel Brake Line Kit

POWER - WITH VACUUM BOOSTER

FRONT DISC/REAR DRUM LINES

BOP58H2.....1958..... OE Steel Brake Line Kit
 BSP58H2.....1958..... Stainless Steel Brake Line Kit
 BOP59H2..... 59-64 OE Steel Brake Line Kit
 BSP59H2..... 59-64 Stainless Steel Brake Line Kit

4-WHEEL DISC LINES

BOP58H4.....1958..... OE Steel Brake Line Kit
 BSP58H4.....1958..... Stainless Steel Brake Line Kit
 BOP59H4..... 59-64 OE Steel Brake Line Kit
 BSP59H4..... 59-64 Stainless Steel Brake Line Kit

PROPORTIONING VALVES

DOES YOUR VALVE LOOK LIKE THIS?



When upgrading to disc brakes or keeping them stock, make sure your proportioning valve is designed for the brake system that is specific to your vehicle.



PVK71 Disc/Drum Proportioning Valve - Brass Finish
 PVK72 Disc/Disc Proportioning Valve - Brass Finish
 PVK71C..... Disc/Drum Proportioning Valve - Chrome Finish
 PVK72C..... Disc/Disc Proportioning Valve - Chrome Finish



1965-UP CHEVY BRAKE LINES

FRONT TO REAR BRAKE LINES

Front to rear brake lines go from the distribution, combination or metering valve along the length of the vehicle to the rear flex hose. Lines are manufactured in 1 or 2 pieces based on factory specifications.

ADD "S" TO PART NUMBER FOR STAINLESS STEEL

BIN650165 All Cars
 BIN660166 All Cars
 BIN6701 .. 67-68 ... All Cars



BIN690169 All Cars
 BIN700170 All Cars
 BIN710171 All Cars
 BIN740174 Caprice Disc/Drum
 BIN750175 All Cars
 BIN780178 All Cars
 BIN9501 .. 95-96 ... Impala SS

BIN6701

FRONT BRAKE LINE KITS

Front brake line kits consist of all brake lines under the hood. This includes the master cylinder to the distribution, combination or metering valve. The left and right front lines that run to the front flex hoses are also included. Call for individual component pricing. These line kits are for vehicles with factory brake systems.

ADD "S" TO PART NUMBER FOR STAINLESS STEEL

BKT650165 Standard Brakes
 BKT650265 Power Brakes
 BKT660166 Standard Brakes
 BKT660266 Power Brakes
 BKT6701 67-68 Standard Drum
 BKT6702 67-68 Power Drum
 BKT6703 67-68 Power Disc
 BKT690169 Standard Drum
 BKT690269 Power Drum

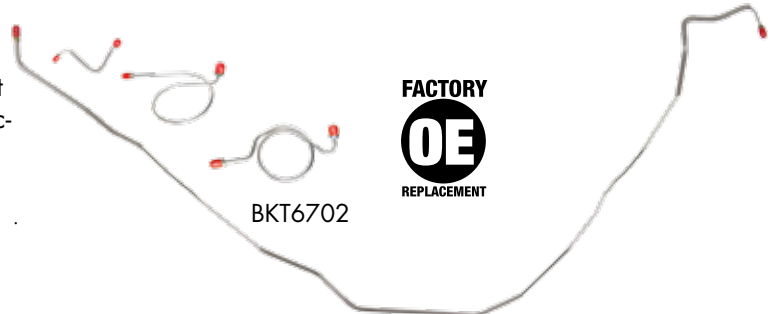

BKT6702

BKT690369 Power Disc..... 5 Pcs
 BKT693369 Power Disc, Super Sport..... 5 Pcs
 BKT700370 Power Disc..... 5 Pcs
 BKT7101 71-73 Power Disc..... 4 Pcs
 BKT740174 Caprice, Power Disc 4 Pcs
 BKT750175 Power Disc..... 4 Pcs
 BKT780178 Power Disc..... 4 Pcs
 BKT9501 95-96 Impala Super Sport..... 6 Pcs

REAR AXLE BRAKE LINES

Rear axle brake lines include a pair of lines that run across the rear axle housing. These lines connect the wheel cylinders or calipers to the flex hose in the middle of the rear end. These lines work with original housings that use factory brakes. Modifications such as rear disc brakes or narrowed rear ends will likely require special lines. Call for more information.

ADD "S" TO PART NUMBER FOR STAINLESS STEEL

BRA6501 65-66 All Cars 2 Pcs.
 BRA6701 67-70 All Cars 2 Pcs.
 BRA7101 71-73 All Cars 2 Pcs.
 BRA740174 Caprice Disc/Drum..... 2 Pcs.
 BRA750175 All Cars..... 2 Pcs.

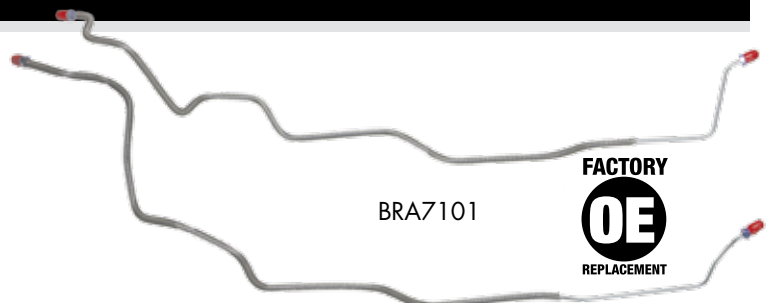

BRA7101

BRA780178 All Cars 2 Pcs.
 BRA840184 Impala..... 2 Pcs.
 BRA890189 Caprice 2 Pcs.
 BRA9501 95-96 Impala SS, Rear Disc..... 2 Pcs.

HOSE HARDWARE

Hose hardware is used to secure flex hoses to various parts of the vehicle. Front brackets are sold in pairs.



RSBB08



FHC01

RSBB08 65-68 Rear Hose Brass 'T' Block with Slot
 FHC01 Correct Gold Cadmium Plated C Clips

WHEEL CYLINDERS

Wheel cylinders are priced individually. Hardware is not included.



WC18

WC17..... 65-70 Left Front
 WC18..... 65-70 Right Front
 WC19..... 65-70 Rear

E-BRAKE CABLES

Parking brake cable sets contain all the individual cables and hardware needed to restore the system. Front, rear, and intermediate cables are also sold individually. While supplies last. Sold in O.E. mild steel and stainless steel. Rear cables and Complete kits listed in this section are for rear drum vehicles. Call for options if you have rear disc brakes.



RSBCB02

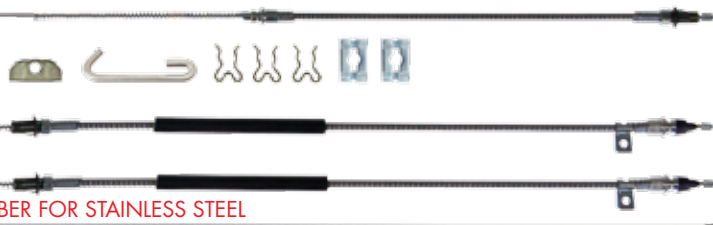

ADD "S" TO PART NUMBER FOR STAINLESS STEEL

• Complete Cable Kits

- RSBCB0165-66..... All Cars
- RSBCB0267-70..... Excluding Turbo 400
- RSBCB0367-70..... Turbo 400*

• Front Brake Cables

- EBC703865-66..... All Cars
- EBC701767-70..... Excluding Turbo 400

• Intermediate Brake Cables

- EBC801565-66..... All Cars
- EBC801767-70..... Excluding Turbo 400

• Rear Brake Cables

- EBC903265-66..... All Cars
- EBC901767-70..... Excluding Turbo 400

• E-Brake Hardware

- RSCLP2365-70 Parking Brake Clip - Black
- EBH201365-66..... 7-3/8" Hook
- EBH300165-70..... Olive Green Center Pull, Chevelle
- EBH100165-66..... Jam Nut
- EBH300265-70..... Center to Rear Silver Connector
- EBH201567-70..... 4-1/2 Hook, Except T-400

FRONT FLEX HOSES

Front flex hoses provide a flexible connection from the body or frame to the front calipers or wheel cylinders as they move during suspension travel. Choose between O.E. rubber or braided stainless steel. All of our hoses are D.O.T. approved. Hoses are priced individually.

FH45



ADD "S" TO PART NUMBER FOR STAINLESS STEEL

- FH45 65-66Front Drum
- FH14 67-70Front Drum
- FH46 67-70Front Disc
- FH09 71-73Front Disc

BRAKE VALVE BRACKETS

These brackets are used to mount various types of valves. Note that many of the valves we sell come with the mounting bracket. See individual valve listings for details.



PVB71



PVB71S

- PVB71 Side Mount Bracket
- PVB71S Side Mount Bracket, Polished Stainless

REAR FLEX HOSES

Rear flex hoses carry brake fluid between the body of the car and the rear. Hoses are available in O.E. rubber and braided stainless steel. 'T' blocks are attached whenever factory correct. All of our hoses are D.O.T. approved. Prices are per hose.

FH36



ADD "S" TO PART NUMBER FOR STAINLESS STEEL

- FH49 65 Rear, All
- FH36 66 Rear, All
- FH50 67-68 Rear, All
- FH51 69-73 Rear, All

VALVES & BLOCKS

We offer a full line of metering blocks, proportioning valves, distribution blocks and combination valves for factory drum and disc brake applications.

PV68



PV01



PV71C



PV72

- PV01Adjustable Valve
- PV6867-69 Hold-Off Valve, No Bracket
- PV71Disc/Drum Combination Valve, Brass
- PV71C.....Disc/Drum Combination Valve, Chrome
- PV72Disc/Disc Combination Valve, Brass
- PV72C.....Disc/Disc Combination Valve, Chrome

1965-UP CHEVY BRAKE BOOSTERS

SLIMLINE BOOSTER MASTER COMBOS

J81315672

The slimline combos offer clean lines and plenty of power in a small package. The 8" dual is our favorite. Mounting brackets included.



J81315672 TOP VIEW

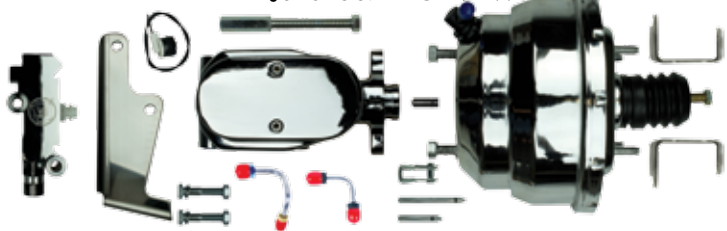

- G84310971 65-70..... Gold 8" Dual, Disc/Drum
- J84315171 65-70..... Chrome 8" Dual Disc/Drum
- G84310572 65-70..... Gold 8" Dual, Disc/Disc
- J84315672 65-70..... Chrome 8" Dual Disc/Disc
- G94020971 65-70..... Gold 9" Single, Disc/Drum

SLIMLINE BOOSTERS

Slimline boosters pack a lot of punch in a small, sleek package. Dual diaphragm versions provide 25% - 35% more assist than their single diaphragm equivalent. The 8" dual is our most popular for clearing big blocks while providing plenty of assist for two or four wheel disc brake systems. Mounting brackets included.



RPB7137



RPB7137C



RPB8131



RPB8131C

- RPB7437 65-70..... 7" Dual, Gold
- RPB7437C 65-70..... 7" Dual, Chrome
- RPB7437S 65-70..... 7" Dual, Stainless
- RPB8431 65-70..... 8" Dual, Gold
- RPB8431C 65-70..... 8" Dual, Chrome
- RPB8431S 65-70..... 8" Dual, Stainless
- RPB9402 65-70..... 9" Single, Gold

DELCO BOOSTER MASTER COMBOS

These combos have a factory looking appearance. Can be tight on big block cars. Mounting brackets included.



G92210971 TOP VIEW

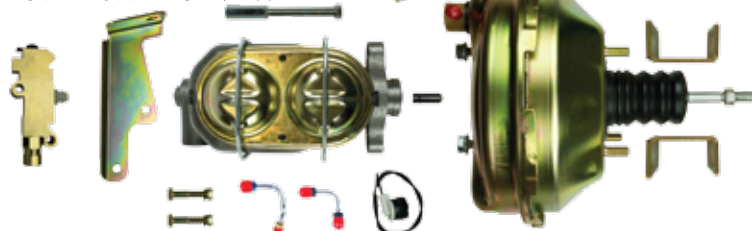

- G94210971 65-70..... Gold 9" Single Disc/Drum
- J94215171 65-70..... Chrome 9" Single, Disc/Drum
- G94210572 65-70..... Gold 9" Single Disc/Disc
- J94215672 65-70..... Chrome 9" single, Disc/Disc
- G14020971 67-70..... Gold 11" Single, Disc/Drum
- G14020572 67-70..... Gold 11" Single, Disc/Disc

DELCO BOOSTERS

Reproductions based on original factory units. Mounting brackets included. *If your booster mounted directly to the firewall, you will need to elongate the holes in your firewall to use our boosters.



RPB9421C



RPB9421

- RPB9421 65-70..... 9" Single, Gold
- RPB9421C 65-70..... 9" Single, Chrome
- RPB1402 67-70..... 11" Single, Gold

RETURN FUEL LINES

Return lines carry excess fuel from fuel pump or fuel filter back to the tank. Not all vehicles were equipped with a return line. Typically 1/4" diameter tubing. Multiple piece sets are noted.

BGL6903 CLOSE UP VIEW



ADD "S" TO PART NUMBER FOR STAINLESS STEEL

- BGL6703 67 1/4" Return Line
- BGL6803 68 1/4" Return Line
- BGL6903 69 1/4" Return Line
- BGL7001 70 1/4" Return Line
- BGL7302 71-76 1/4" Return Line
- BGL7403 74 1/4" Return Line, Caprise

1965-UP CHEVY MASTER CYLINDERS & LINES

MASTER CYLINDERS

Most master cylinders are completely new units with no core charge. A deep cylinder pocket with a removable plug provides compatibility with manual brakes as well as power-assisted applications.



DBMC51C

- DBMC0767-69... Power Drum, 1" Bore, ** Rebuilt
- DBMC0967-69... Power Disc, 1-1/8" Bore, Deep Pocket
- DBMC1167-69... Power Disc, with Bleeders, 1-1/8" Bore, Deep, Exact Repo for '69, Delco Licensed
- DBMC1667-69... Power Disc, with Bleeders, 1-1/8" Bore, Deep, Same as DBMC11 without Casting Marks
- DBMC0170-80... Power Disc, 1-1/8" Bore, Shallow Pocket
- DBMC09C...67-69... 1-1/8" Bore, Chrome
- DBMC05C...67-69... 1" Bore, Chrome
- DBMC51C...67-69... 1 1/8" Bore, Slimline Flat Top, Chrome
- DBMC56C...67-69... 1" Bore, Slimline Flat Top, Chrome

FUEL PUMP TO CARB LINES

Fuel pump to carburetor lines connect the fuel pump to the carburetor. Brass blocks and fittings are included as noted. These lines are intended to work only with factory pump, motor, intake and carburetor combinations.

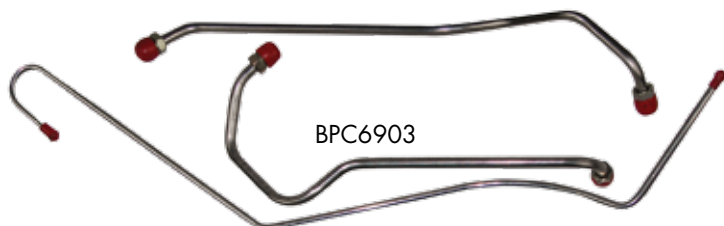

BPC6903

ADD "S" TO PART NUMBER FOR STAINLESS STEEL

- BPC6202..... 65..... 327/300 HP with L-74 Option, 2-Pc.
- BPC6609... 65-66 ... 396 Impala with Quadrajel
- BPC6602... 65-67 ... 283, 2 BBL
- BPC6603..... 66..... 426 Impala with 2Edlebrook 4 BBLs 3-Piece
- BPC6604..... 66..... 327/ 275 HP, Carter, Enters Rear
- BPC6606..... 66..... 250, 6 Cylinder
- BPC6709..... 67..... 427 with Quadrajel
- FPC6705 ... 67-69 ... 327/275 HP, 5/16" Line
- FPC6707 ... 67-69 ... 327/275 HP, 3/8" Line
- FPC6709 ... 67-69 ... 396/325 HP with Quadrajel
- BPC6803..... 68..... 427-SS Quadrajel, Used with FFF6901 Filter, 3-Piece.
- BPC6904..... 69..... 396/265, 2 BBL, with Filter
- FPC6901 69..... 350, 2 BBL
- BPC6901 69..... 350/300 HP Bel Air 4BBL, Quadrajel
- BPC6903... 69-70 ... 396 with Quadrajel, 3-Piece.
- BPC7501 75..... 350, 2 BBL

FUEL HOSE KITS

These small rubber hoses and clips are used to connect fuel lines to the fuel pump and sending unit.

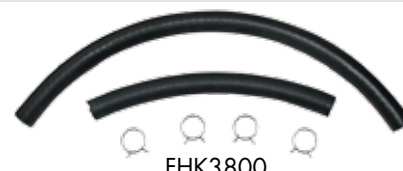

FHK3800

- FHK3800.....ALL..... 3/8" x 6", 3/8" x 13", + 4 Green Clamps
- FHK1438.....ALL..... 3/8" x 6", 3/8" x 13", 1/4" x 18" + 4 Green Clamps and 4 Red Clamps

POWER STEERING LINES

Power steering lines can be either pressure or return feeds in a power steering system.

- BPS7001 67-72 ... All Cars

DISTRIBUTOR VACUUM LINES

Distributor vacuum lines supply intake vacuum to the distributor for timing control.

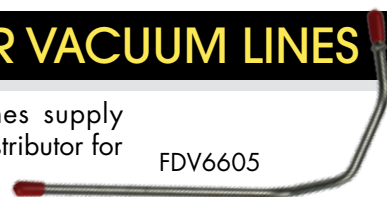

FDV6605

ADD "S" TO PART NUMBER FOR STAINLESS STEEL

- BDV6601 66..... 250, 6 Cylinder
- BDV6602 66..... 283, 2 BBL
- BDV6604 66..... 327, Carter Carb.
- XDV6601 66..... 2 BBL
- FDV6605..... 66-69 ... Big Block, with Holley Carb.
- FDV6703..... 67-70 ... Small Block, 4 BBL, Dist. Vacuum
- FDV6707..... 67-72 ... Small Block, 2 BBL
- CDV6805..... 68-72 ... Big Block, 4 BBL, Dist. Vacuum
- BDV6902 69..... 396, 2 BBL
- BDV7005 70..... Big Block with Quadrajel, 2-Piece.

VAPOR RETURN LINES

Emission control systems use these 5/16" lines to handle fuel vapors. Some vehicles use a single front to rear line. Others utilize a charcoal canister and require 3 or 4 additional small lines. Multiple piece sets are noted.

ADD "S" TO PART NUMBER FOR STAINLESS STEEL

- BGL7003 70..... 5/16" Vapor Line
- BGL7303..... 71-76 ... 5/16" Vapor Return Line
- BGL7802..... 78..... 5/16" Vapor Return Line

THERMAL CHOKE LINES

Thermal choke lines carry heat from the exhaust system to the choke coil on the carburetor. Some applications route thru the intake manifold on their way to the carburetor.

- BCH570165-70..... 6 Cylinder 235 - OE Steel
- BCH5701S65-70..... 6 Cylinder 235 - Stainless

1965-UP CHEVY FUEL LINES & TANKS

MAIN FUEL LINES

Main lines carry fuel from the tank in the rear of the car to the fuel pump or rail in the front. They are available in 3/8" and 5/16" tubing based on factory specifications. Multiple piece sets are noted. Call for 1/2" lines.

BGL6702

ADD "S" TO PART NUMBER FOR STAINLESS STEEL

BGL6501 65-66 5/16" Small Block
 BGL6502 65-66 3/8" Big Block
 BGL6503 65-66 3/8" Station Wagon
 BGL6701 67-68 5/16" Small Block
 BGL6702 67-68 3/8" Big Block
 BGL6901 69 5/16" Small Block
 BGL6902 69 3/8" Big Block

BGL6904 69 3/8" Bel Air 350/300 HP
 BGL7002 70 3/8" Main Line
 BGL7101 71 5/16" Main Line
 BGL7301 71-76 3/8" Main Line
 BGL7401 74 3/8" Caprice Main Line
 BGL7402 74 5/16" Caprice Vent Line
 BGL7801 78 3/8" Main Line

FUEL TANK VENT LINES

Fuel tank vent lines allow the air inside the fuel tank to escape as it is filled with fuel. They also prevent pressure from building up due to temperature changes.

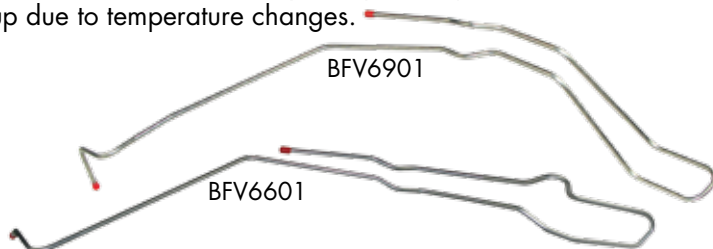

ADD "S" TO PART NUMBER FOR STAINLESS STEEL

BFV6501 65 All Cars
 BFV6601 66-69 Trunk Mtd. Vent Line, Hardtop
 BFV6901 66-69 Trunk Mtd. Vent Line, Convertible
 BFV7801 78 All Cars 2 Pcs.

FUEL TANKS

Fuel tanks are constructed of Ni-Terne steel. Hardware is not included.



BFT6801 68 Chevy
 BST6801 68 Chevy - Stainless

TRANSMISSION COOLER LINES

Transmission cooler lines are sold as pairs. Be sure to verify the type of transmission in your project before ordering. These lines are intended to work only with factory motor, transmission, and radiator combinations.

ADD "S" TO PART NUMBER FOR STAINLESS STEEL

BTC6501 65 Small Block Rad. Fittings, 12" Span
 BTC6502 65-66 Big Block with Powerglide, 2-1/2" Span
 BTC6602 66 12" Span with Loop In Pass Side Line
 BTC6601 66-67 Small Block Rad. Fittings, 12" Span
 BTC6702 67 Big Block, Turbo 400 & Powerglide
 BTC6805 67-68 Small Block, Turbo 400 & Powerglide
 BTC6814 68-69 Big Block with TH400 & Powerglide, 2-1/2" Span
 BTC6815 68-69 Big Block with TH400 & Powerglide, 12" Span
 BTC6905 69 Small Block, Powerglide
 BTC7005 69-70 Big Block with Turbo 400
 BTC7401 74 Caprice 350hp
 BTC7501 75 Small Block, TH-350

TRANSMISSION VACUUM LINES

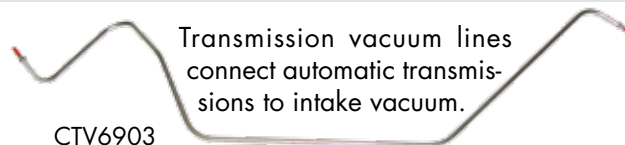

ADD "S" TO PART NUMBER FOR STAINLESS STEEL

CTV6605 66 Turbo 400, 396/360 HP, 2-Pc.
 CTV6703 67-68 Turbo 350, Left Side Modulator
 CTV6701 67-69 Powerglide
 CTV6704 67-68 Turbo 400
 BTV6905 69 Turbo 400
 CTV6903 69-72 Turbo 350, Right Side Modulator
 BTV7005 70 Turbo 400



1965-UP CHEVY FRONT BRAKE CONVERSIONS

**STREET
SERIES**

FRONT DISC BRAKE CONVERSION KITS

U.S.A. Made
TIMKEN Bearings

FRONT CONVERSIONS INCLUDE:

- 11" Rotors
- Spindles (2" Drop Only)
- Timken Bearings
- New Calipers
- Caliper Brackets
- Organic Pads
- Backing Plates
- Flex Hoses & Clips
- Valve Bracket & Hardware
- Banjo Bolts & Copper Washers
- Dust Caps
- Castle Nuts & Pins
- Washers
- Grease Seals
- Spindle Gaskets
- Steering Arm Bolts
- Master Cylinder
- Combination Valve
- Pedal Rod Extension
- Brake Switch Pigtail

Right Stuff disc conversions are the most complete kits in the industry at the right price. High quality components, professional packaging, and after-sale support by "hands-on" technicians create an unbeatable value. Consider one of our complete brake line packages for a care-free installation.



Packages include At-the-Wheel Disc Conversion Kit & Master Cylinder with Valve (Manual) or Master Cylinder with Booster and Valve (Power).

POWER PACKAGE

MANUAL PACKAGE

9" inch booster, Call for other diameters

FITS 15" & LARGER WHEELS

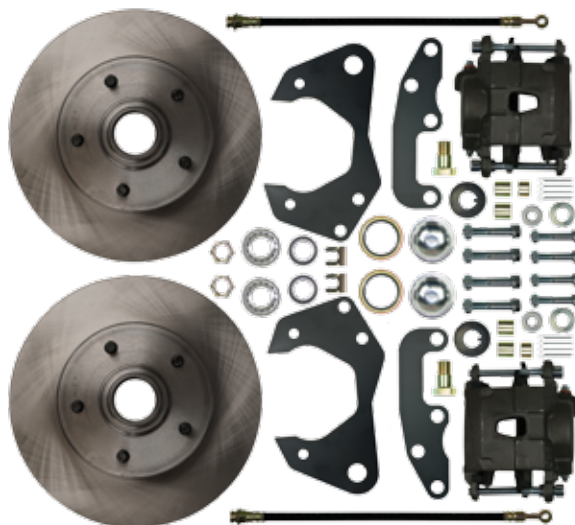

AT-THE-WHEEL FRONT KITS

STOCK HEIGHT FRONT KITS

- FSC65WKC65-68..... At-the-Wheel Disc Conversion Kit
- FSC65SDC.....65-68..... Manual Disc Conversion Package
- FSC65DCC.....65-68..... Power Disc Conversion Package

2" DROP FRONT KITS

- FSC65WKD65-70..... At-the-Wheel Disc Conversion Kit
- FSC65SDD.....65-70..... Manual Disc Conversion Package
- FSC65DCD65-70..... Power Disc Conversion Package

UPGRADES

The next page offers upgrades to fully customize your conversion kit.

SUSPENSION KITS

These prepackaged kits offer huge savings over individual suspension parts. Most kits include the following:

Standard rubber kits meet O.E. specifications. Polyurethane kits provide better handling & a firmer ride. Poly kits include upgraded control arm bushings, sway bar bushings & links.



- Lower Ball Joints (2)
- Upper Ctrl. Arm Bushings (4)
- Lower Ctrl. Arm Bushings (4)
- Lower Ball Joints (2)
- Outer Tie Ro (2)
- Inner Tie Rods (2)

- BSK6568.....65-68..... Rebuild Kit, 18 Pcs. Susp. Kit
- BSK6970.....69-70..... Rebuild Kit, 18 Pcs. Susp. Kit

**COMING
IN 2017**

1965-UP CHEVY FRONT BRAKE UPGRADES

FRONT DISC BRAKE CONVERSION UPGRADES

STREET SERIES

SHOW'N GO UPGRADE TRIM KITS

These At-the-Wheel Disc Conversion Kits (stock height or 2" drop) include upgraded drilled slotted rotors with zinc plating, powder coated calipers in red or black, and braided stainless hoses.



STOCK HEIGHT SHOW'N GO

FSC65WKCS ... 65-68... At-the-Wheel Disc Conversion Kit - Black
 FSC65WKCZ ... 65-68... At-the-Wheel Disc Conversion Kit - Red
 FSCSD65CS 65-68... Manual Disc Conversion Package - Black
 FSCSD65CZ 65-68... Manual Disc Conversion Package - Red
 FSCDC65CS 65-68... Power Disc Conversion Package - Black
 FSCDC65CZ 65-68... Power Disc Conversion Package - Red

2" DROP SHOW'N GO

FSC65WKDS ... 65-70... 2" Drop At-the-Wheel Disc Conv Kit - Black
 FSC65WKDZ ... 65-70... 2" Drop At-the-Wheel Disc Conv Kit - Red
 FSCSD65DS 65-70... 2" Drop Manual Disc Conv Pkg - Black
 FSCSD65SDZ ... 65-70... 2" Drop Manual Disc Conv Pkg - Red
 FSCDC65DS 65-70... 2" Drop Power Disc Conv Pkg - Black
 FSCDC65DZ 65-70... 2" Drop Power Disc Conv Pkg - Red

SHOW STOPPER TRIM PACKAGES

Includes At-the-Wheel Front Disc Conversion Kit (stock height or 2" drop) with natural finish calipers. The Manual Packages get an upgraded chrome plated master cylinder and combination valve with bracket. Power Packages include an upgraded 8" dual chrome booster.

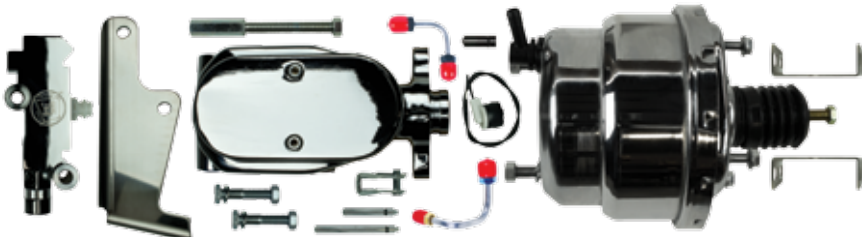

STOCK HEIGHT SHOW STOPPER

FSC65SDCX 65-68 Manual Disc Conversion Package
 FSC65DCCX 65-68 Power Disc Conversion Package

2" DROP SHOW STOPPER

FSC65SDDX 65-70 ... 2" Drop Manual Disc Conversion Package
 FSC65DCDX ... 65-70 ... 2" Drop Power Disc Conversion Package

BEST OF SHOW TRIM PACKAGES

Includes At-the-Wheel Front Disc Conversion Kit (stock height or 2" drop) with black or red calipers, drilled & slotted rotors & braided stainless hoses. The Manual Packages get an upgraded chrome plated master cylinder and combination valve with bracket. Power Packages include an upgraded 8" dual chrome booster.



STOCK HEIGHT BEST OF SHOW

FSC65SDCSX 65-68 Manual Disc Conversion Package - Black
 FSC65SDCZX 65-68 Manual Disc Conversion Package - Red
 FSC65DCCSX ... 65-68 Power Disc Conversion Package - Black
 FSC65DCCZX ... 65-68 Power Disc Conversion Package - Red

2" DROP BEST OF SHOW

FSC65SDDSX 65-70 Manual Disc Conversion Package - Black
 FSC65SDDZX 65-70 Manual Disc Conversion Package - Red
 FSC65DCDSX ... 65-70 Power Disc Conversion Package - Black
 FSC65DCDZX ... 65-70 Power Disc Conversion Package - Red



Front Disc Brake Conversions require special brake lines that fit your new disc conversion setup. Right Stuff offers "No Brainer" Brake Line Kits that include all components needed from your master cylinder back to your rear wheel cylinder or calipers. They include front brake line kit, front to rear line, rear axle lines & flex hose, & clip set.

See page 124 for your application

1965-UP CHEVY 4-WHEEL BRAKE CONVERSIONS

**STREET
SERIES**

FOUR WHEEL DISC BRAKE CONVERSION KITS

**WORKS WITH 15"
AND LARGER WHEELS**

FOUR WHEEL CONVERSIONS INCLUDE:



- 11" Rotors
- Spindles (2" Drop Only)
- Timken Bearings
- New Calipers
- Caliper Brackets
- Organic Pads
- Backing Plates
- Flex Hoses & Clips
- Valve Bracket & Hardware
- Banjo Bolts & Copper Washers
- Rear Bracket Spacers
- Weld-On Hose Brackets
- Dust Caps
- Castle Nuts & Pins
- Washers
- Grease Seals
- Spindle Gaskets
- Steering Arm Bolts
- Master Cylinder
- Combination Valve
- Pedal Rod Extension
- Brake Switch Pigtail
- E-Brake Cables

Kits have an offset of 3/8" per side.

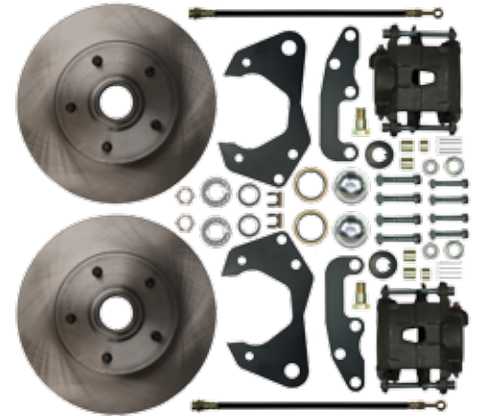

AT-THE-WHEEL FRONT KIT

Right Stuff disc conversions are the most complete kits in the industry at the right price. High quality components, professional packaging, and after-sale support by "hands-on" technicians create an unbeatable value. Consider one of our complete brake line packages for a care-free installation. See page 112 to verify axle flange measurements for these kits.



Packages include At-the-Wheel Disc Conversion Kits & Master Cylinder with Valve (Manual) or Master Cylinder with Booster and Valve (Power).

POWER PACKAGE

MANUAL PACKAGE

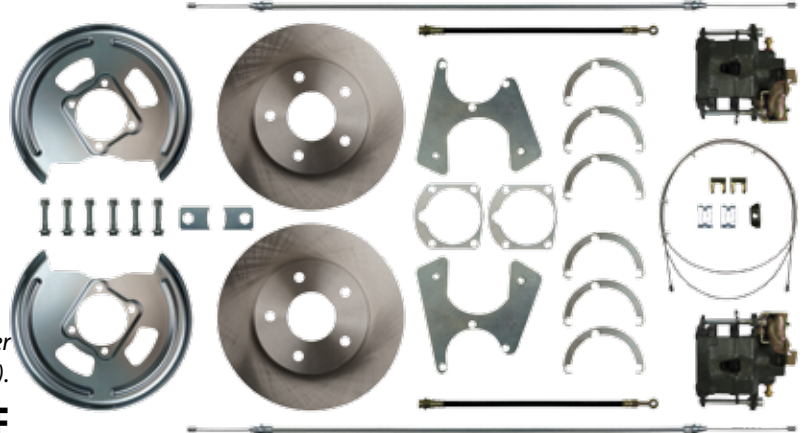

6-3/16" INSIDE ROTOR DIAMETER - 2.78" CENTER HOLE

AT-THE-WHEEL REAR KIT

STOCK HEIGHT 4-WHEEL KITS

FSC654SDC....65-68 ...Manual Disc Brake Conversion Package
FSC654DCC65-68 ...Power Disc Brake Conversion Package

2" DROP 4-WHEEL KITS

FSC654SDD....65-70 ...2" Drop Manual Disc Brake Conv Package
FSC654DCD ...65-70 ...2" Drop Power Disc Brake Conv Package

UPGRADES Below & the next page offer upgrades to fully customize your conversion kit.

4-WHEEL DISC BRAKE CONVERSION UPGRADES **STREET
SERIES**

SHOW STOPPER TRIM PACKAGES

Includes At-the-Wheel Front Disc Conversion Kit (stock height or 2" drop) with natural finish calipers. The Manual Packages get an upgraded chrome plated master cylinder and combination valve with bracket. Power Packages include an upgraded 8" dual chrome booster.

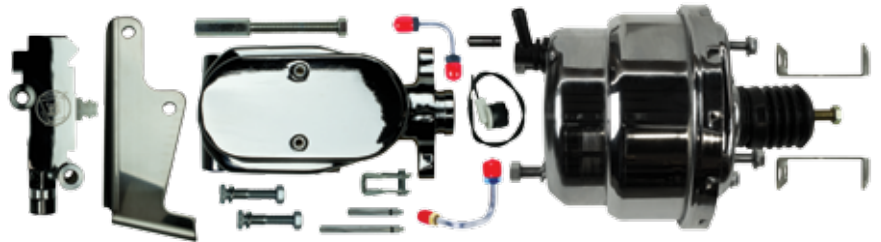

STOCK HEIGHT SHOW STOPPER

2" DROP SHOW STOPPER

FSC654SDCX.... 65-68 ... Manual Disc Brake Conversion Package
FSC654DCCX ... 65-68 ... Power Disc Brake Conversion Package

FSC654SDDX.... 65-70 ... 2" Drop Manual Disc Brake Conv Pkg
FSC654DCDX ... 65-70 ... 2" Drop Power Disc Brake Conv Pkg

1965-UP CHEVY 4-WHEEL & REAR BRAKE UPGRADES

4-WHEEL DISC BRAKE CONVERSION UPGRADES

**STREET
SERIES**

BEST OF SHOW TRIM PACKAGES

Includes At-the-Wheel Front Disc Conversion Kit (stock height or 2" drop) with black or red calipers. The Manual Packages get an upgraded chrome plated master cylinder and combination valve with bracket. Power Packages include an upgraded 8" dual chrome booster.

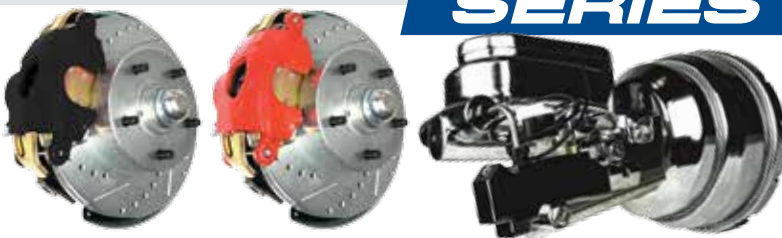

STOCK HEIGHT BEST OF SHOW

FSC654SDCSX....65-68 ...Manual Disc Brake Conv Package - Black
 FSC654SDCZX....65-68 ...Manual Disc Brake Conv Package - Red
 FSC654DCCSX....65-68 ...Power Disc Brake Conv Package - Black
 FSC654DCCZX ...65-68 ...Power Disc Brake Conv Package - Red

2" DROP BEST OF SHOW

FSC654SDDSX... 65-70...2" Drop Manual Disc Brake Conv Pkg - Black
 FSC654SDDZX... 65-70...2" Drop Manual Disc Brake Conv Pkg - Red
 FSC654DCDSX .. 65-70...2" Drop Power Disc Brake Conv Pkg - Black
 FSC654DCDZX .. 65-70...2" Drop Power Disc Brake Conv Pkg - Red

**STREET
SERIES**

REAR DISC BRAKE CONVERSION KITS

REAR CONVERSIONS INCLUDE:

- 11" Rotors
- Brackets & Spacers
- Weld-On Hose Brackets
- Flex Hoses
- Backing Plates (Exclusive)
- New Loaded Caliper
- E-Brake Cables
- Hardware

NOTE:
 FITS FACTORY
 REAR ENDS
 CALL FOR CUSTOM
 APPLICATIONS

Right Stuff disc conversions are the most complete kits in the industry at the right price. High quality components, professional packaging, and after-sale support by "hands-on" technicians create an unbeatable value. Consider one of our complete brake line packages for a care-free installation. See page 112 to verify axle flange measurements for these kits.

WORKS WITH 15" AND LARGER WHEELS

6 3/16" INSIDE ROTOR DIAMETER - 2.78" CENTER HOLE

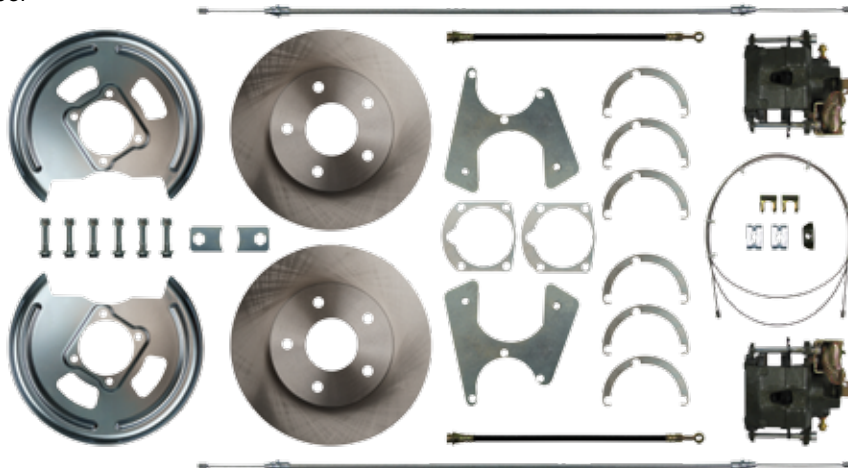

ATTENTION Before you order, be sure to measure the axle flange on your vehicle.

KITS WITH E-BRAKE

FSCRD01 65-70Factory Rear with Drop Out Axles

KITS WITHOUT E-BRAKE

FSCRDM1 65-70Factory Rear with Drop Out Axles

REAR DISC BRAKE CONVERSION UPGRADES

**STREET
SERIES**

SHOW'N GO UPGRADE TRIM PACKAGES

These Rear Disc Conversion Kits include upgraded drilled slotted rotors with zinc plating, powder coated calipers in red or black, and braided stainless hoses.



REAR UPGRADE WITH E-BRAKE

FSCRD01S 65-70Factory Rear with Drop Out Axles - Black
 FSCRD01Z.... 65-70Factory Rear with Drop Out Axles - Red

REAR UPGRADE W/O E-BRAKE

FSCRDM1S ... 65-70Factory Rear with Drop Out Axles - Black
 FSCRDM1Z... 65-70Factory Rear with Drop Out Axles - Red

1965-UP CHEVY BRAKE LINES & SUSPENSION



No Brainer BRAKE LINE KITS FOR DISC CONVERSIONS

When you add disc brakes to your car you are using a new valve that has different size ports pointing in different directions. Even if your lines are brand new or great originals, you are going to have issues trying to use them. Our No Brainer Brake Line Kit fixes all these issues from your master cylinder all the way back to your rear wheel cylinders or rear calipers. We give you all the lines to complete the installation. We also include the rear flex hose and a full clip set to install your lines. Extremely discounted prices and great instructions make this kit a No Brainer.

SIMPLIFY YOUR DISC BRAKE CONVERSION INSTALLATION WITH ALL OF THE BRAKE LINES YOU WILL NEED.

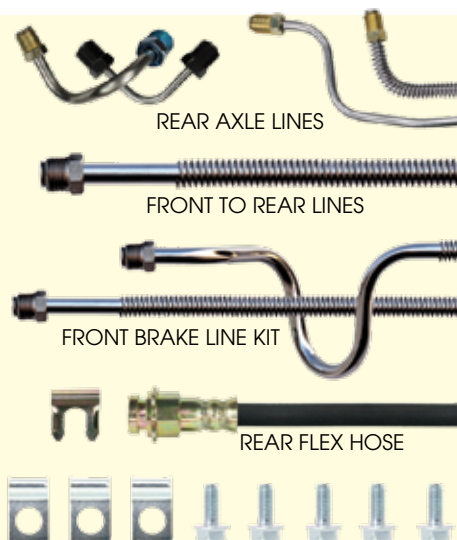

BRAKE ELINES & PROPORTIONING VALVES

MANUAL - NO VACUUM BOOSTER FRONT DISC/REAR DRUM LINES

BOM65H2.....65-66..... OE Steel Brake Line Kit
BSM65H2.....65-66..... Stainless Steel Brake Line Kit
BOM67H2.....67-68..... OE Steel Brake Line Kit
BSM67H2.....67-68..... Stainless Steel Brake Line Kit

POWER - WITH VACUUM BOOSTER FRONT DISC/REAR DRUM LINES

BOP65H2.....65-66..... OE Steel Brake Line Kit
BSP65H2.....65-66..... Stainless Steel Brake Line Kit
BOP67H2.....67-68..... OE Steel Brake Line Kit
BSP67H2.....67-68..... Stainless Steel Brake Line Kit

4-WHEEL DISC LINES

BOM65H4.....65-66..... OE Steel Brake Line Kit
BSM65H4.....65-66..... Stainless Steel Brake Line Kit
BOM67H4.....67-68..... OE Steel Brake Line Kit
BSM67H4.....67-68..... Stainless Steel Brake Line Kit

4-WHEEL DISC LINES

BOP65H4.....65-66..... OE Steel Brake Line Kit
BSP65H4.....65-66..... Stainless Steel Brake Line Kit
BOP67H4.....67-68..... OE Steel Brake Line Kit
BSP67H4.....67-68..... Stainless Steel Brake Line Kit

DOES YOUR VALVE LOOK LIKE THIS?



When upgrading to disc brakes or keeping them stock, make sure your proportioning valve is designed for the brake system that is specific to your vehicle.

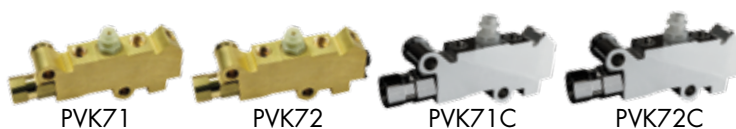

PVK71..... Disc/Drum Proportioning Valve - Brass Finish
PVK72..... Disc/Disc Proportioning Valve - Brass Finish
PVK71C..... Disc/Drum Proportioning Valve - Chrome Finish
PVK72C..... Disc/Disc Proportioning Valve - Chrome Finish

SUSPENSION PARTS

**COMING
IN 2017**

UPPER & LOWER BALL JOINTS

XK6035 XK6034

XK6035.....58-64..... Lower
XK6034.....58-64..... Upper

UPPER & LOWER CONTROL ARM BUSHING KITS

XK5196.....65-70..... Upper
XK6134.....65-70..... Lower



INNER & OUTER TIE RODS & SLEEVES

XES350L

XES370R.....65-68..... Inner
XES350L.....65-68..... Outer
XES350S.....65-70..... Adjusting Sleeve
XES378R.....69-70..... Inner
XES378L.....69-70..... Outer

SWAY BAR BUSHINGS

XK5227.....65-70..... All

XK5227

GM TRUCK DISC BRAKE CONVERSIONS

**STREET
SERIES**

FRONT DISC BRAKE CONVERSION KITS

FRONT CONVERSIONS INCLUDE:

- Rotors
- New Calipers
- Brake Pads
- Flex Hoses
- Master Cylinder
- Castle Nuts & Pins
- Washers
- Grease Seals
- Proportioning Valve
- Pedal Rod Extension
- Booster (Power Kits Only)
- Bearings
- Banjo Bolts
- Valve Bracket
- Dust Caps

Right Stuff disc conversions are the most complete kits in the industry at the right price. High quality components, professional packaging, and after-sale support by "hands-on" technicians create an unbeatable value. Consider one of our complete brake line packages for a carefree installation.



1963-70 SHOWN WITH OPTIONAL SUSPENSION UPGRADE



1947-54

BBK4754 (BRACKET ONLY)



1955-59

BBK5559 (BRACKET ONLY)

FRONT MANUAL KITS

1947-59 Front Disc Manual Conversion Packages

- TSD4705 47-59 5 x 4.75" - OE Spindles
- TSD4706 47-59 6 x 5.5" - OE Spindles*
- WBK47 47-59 6 Lug Roller Bearing Upgrade (*Required)

1960-62 Front Disc Manual Conversion Packages

- TSD6015 60-62 ... 5 x 5" - New Spindles
- TSD6015D.. 60-62 ... 5 x 5" - 2" Drop
- TSD6016 60-62 ... 6 x 5.5" - New Spindles
- TSD6016D.. 60-62 ... 6 x 5.5" - 2" Drop

1963-70 Front Disc Manual Conversion Packages

- TSD6305 63-70 ... 5 x 4.75" - OE Spindles
- TSD6315 63-70 ... 5 x 5" - New Spindles
- TSD6315D..... 63-70 ... 5 x 5" - 2" Drop
- TSD6315S 63-70 ... 5 x 5" - Suspension Upgrade
- TSD6315SD... 63-70 ... 5 x 5" - Suspension Upgrade, 2" Drop
- TSD6316 63-70 ... 6 x 5.5" - New Spindles
- TSD6316D..... 63-70 ... 6 x 5.5" - 2" Drop
- TSD6316S 63-70 ... 6 x 5.5" - Suspension Upgrade
- TSD6316SD... 63-70 ... 6 x 5.5" - Suspension Upgrade, 2" Drop

FRONT POWER KITS

1947-59 Front Disc Power Conversion Packages

- TDC4705 ... 47-59 5 x 4.75" - OE Spindles
- TDC4706 ... 47-59 6 x 5.5" - OE Spindles*
- WBK47 47-59 6 Lug Roller Bearing Upgrade (*Required)

1960-62 Front Disc Power Conversion Packages

- TDC6015 60-62... 5 x 5" - New Spindles
- TDC6015D ... 60-62... 5 x 5" - 2" Drop
- TDC6016 60-62... 6 x 5.5" - New Spindles
- TDC6016D ... 60-62... 6 x 5.5" - 2" Drop

1963-70 Front Disc Power Conversion Packages

- TDC6305 63-70 ... 5 x 4.75" - OE Spindles
- TDC6315 63-70 ... 5 x 5" - New Spindles
- TDC6315D 63-70 ... 5 x 5" - 2" Drop
- TDC6315S..... 63-70 ... 5 x 5" - Suspension Upgrade
- TDC6315SD .. 63-70 ... 5 x 5" - Suspension Upgrade, 2" Drop
- TDC6316 63-70 ... 6 x 5.5" - New Spindles
- TDC6316D 63-70 ... 6 x 5.5" - 2" Drop
- TDC6316S..... 63-70 ... 6 x 5.5" - Suspension Upgrade
- TDC6316SD .. 63-70 ... 6 x 5.5" - Suspension Upgrade, 2" Drop



COMPLETE BRAKE SETS

ADD "S" TO PART NUMBER FOR STAINLESS STEEL

TBS360136 1/2 Ton, 112" WB, FB 6 Pcs.
TBS370137 Manual Drum, Shortbed 9 Pcs.
TBS6401	.. 41-46	... Manual Drum, Shortbed 7 Pcs.
TBS4701	.. 47-51	... Manual Drum, Shortbed 7 Pcs.
TBS503450 Man. Drum, 3/4 Ton, Longbed	7 Pcs.
TBS530153 Manual Drum, Longbed 5 Pcs.
TBS540154 Manual Drum, Shortbed 6 Pcs.
TBS5501	.. 55-56	... Manual Drum, Shortbed 6 Pcs.
TBS5502	.. 55-56	... Manual Drum, LB, Series II 4 Pcs.
TBS570157 Manual Drum, Shortbed 6 Pcs.
TBS5801	.. 58-59	... Manual Drum, Shortbed 7 Pcs.
TBS5802	.. 58-59	... Manual Drum, Longbed 7 Pcs.
TBS580858 Apache 3800 Manual Drum 6 Pcs.
TBS6001	.. 60-63	... Manual Drum, Shortbed 7 Pcs.
TBS6002	.. 60-63	... Manual Drum, Longbed 6 Pcs.
TBS6401	.. 64-66	... Manual Drum, Shortbed 7 Pcs.
TBS6402	.. 64-66	... Manual Drum, Longbed 7 Pcs.
TBS6404	.. 64-66	... Chevy 4x4 Brake Kit 8 Pcs.

FRONT BRAKE FLEX HOSES

Front flex hoses provide a flexible connection from the body or frame to the front calipers or wheel cylinders as they move during suspension travel. All of our hoses are D.O.T. approved. Hoses are priced individually.

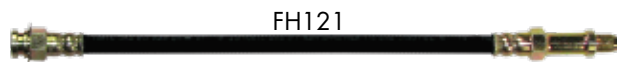

FH121

FH11738-50 All
FH11851-56 3100
FH119 57 3100 with 4WD
FH12057-59 3200
FH12160-66 C10 or K10
FH12161-65 P10

REAR BRAKE FLEX HOSES

Rear flex hoses carry brake fluid between the body of the car and the rear. Hoses are available in O.E. rubber. 'T' blocks are attached whenever factory correct. All of our hoses are D.O.T. approved. Prices are per hose.

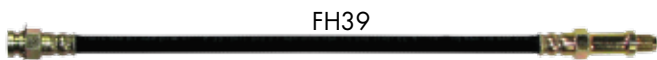

FH39

FH11738-50 All
FH11751-56 3100
FH11757-59 3200
FH3957-59 3100 with 2 WD
FH128 60 C10 with Longbed
FH11960-66 K10
FH11761-62 P10
FH12961-62 C10 with Shortbed
FH13063-66 C10 with Longbed
FH12664-65 All with Shortbed

REAR AXLE BRAKE LINES

Rear axle brake lines include a pair of lines that run across the rear axle housing. These lines connect the wheel cylinders or calipers to the flex hose in the middle of the rear end. These lines work with original housings that use factory brakes. Modifications such as rear disc brakes or narrowed rear ends will likely require special lines. Call for more information.



TRA6401

ADD "S" TO PART NUMBER FOR STAINLESS STEEL

TRA3701 37 Standard Duty
TRA4601 46 Standard Duty
TRA470147-51 Standard Duty
TRA5401 54 Standard Duty
TRA550155-57 Series II & Standard Duty
TRA580158-59 Standard Duty
TRA600160-63 Standard Duty
TRA640164-66 Standard Duty

WHEEL CYLINDERS

Wheel cylinders are priced each. Hardware is not included.



WC48

WC49

WC3338-50 All Front
WC4638-50 All Rear
WC3451-59 Except 4 WD, Left Front
WC3551-59 Except 4 WD, Right Front
WC4751-55 51-55 Series I, All Rear
WC11 55 Series II-59 without Positraction Left Rear
WC12 55 Series II-59 without Positraction Right Rear
WC4858-59 3100 or 3200, Left with Positraction Rear
WC4958-59 3100 or 3200, Right Rear
WC13 60 K10 Canadian, Left Front
WC14 60 K10, Canadian, Right Front
WC1360-63 C10, Left Front
WC1460-63 C10, Right Front
WC1361-63 P10, Left Front
WC1461-63 P10, Right Front
WC3464-69 K10, Left Front
WC3564-69 K10, Right Front
WC4364-69 K10, Right with 10" Front Drums Front
WC1160-70 C10 or K10, Left Rear
WC1260-70 C10 or K10, Right Rear
WC1164-70 P10, Left Rear
WC1264-70 P10, Right Rear

FLEX HOSE HARDWARE

Hose hardware is used to secure flex hoses to various parts of the vehicle.

FHC01 Correct Gold Cadmium Plated C Clips
-------	-------	---

FUEL PUMP TO CARB LINES

Fuel pump to carburetor lines connect the fuel pump to the carburetor. Brass blocks and fittings are included as noted. These lines are intended to work only with factory pump, motor, intake and carburetor combinations.

ADD "S" TO PART NUMBER FOR STAINLESS STEEL

TPC3701	37	6 Cylinder
TPC4201	42	6 Cylinder
TPC4701	47	6 Cylinder
TPC4901	49	Chevy 3100, 216 Motor
TPC5401	54	6 Cylinder
TPC5802	58	8 Cylinder, with 2 BBL
TPC5801	58-59	6 Cylinder
TPC6002	60-63	8 Cylinder with 2 BBL
TPC6401	64	6 Cylinder
TPC6402	64-66	8 Cylinder with 2 BBL

MAIN FUEL LINES

Main lines carry fuel from the tank in the rear of the car to the fuel pump or rail in the front. Call for 1/2" lines.

ADD "S" TO PART NUMBER FOR STAINLESS STEEL

TGL4101	41-46	1/2 Ton
TGL4701	47-53	5/16" 6 Cylinder
TGL5401	54	5/16" 6 Cylinder, Shortbed
TGL5601	55	5/16" 6 Cyl, Longbed, 2-Piece
TGL5501	55-57	5/16" 6 Cyl, Shortbed
TGL5801	58-59	5/16" 6 Cyl, Shortbed, 2-Piece
TGL5802	58-59	5/16" 6 Cyl, Longbed
TGL6001	60-63	5/16", Shortbed, 2-Piece
TGL6002	60-63	3/8", Shortbed, 2-Piece.
TGL6003	60-63	5/16" Longbed, 2-Piece
TGL6401	64-66	5/16", Shortbed, 2-Piece
TGL6402	64-66	3/8", Shortbed, 2-Piece
TGL6403	64-66	5/16", Longbed, 2-Piece
TGL6404	64-66	5/16", Suburban, 3-Piece

DISTRIBUTOR VACUUM LINES

Lines supply intake vacuum to the distributor for timing control.

ADD "S" TO PART NUMBER FOR STAINLESS STEEL

TDV4201	42	216, 6 Cylinder - OE Steel
TDV4701	47-53	216, 6 Cylinder - OE Steel
TDV5801	58-59	6 Cylinder - OE Steel

TRANSMISSION VACUUM LINES

Trans vacuum lines connect automatic trans to intake vacuum.

TTV6403	64-66	Turbo 350 - OE Steel
TTV6403S	64-66	Turbo 350 - Stainless

HYDRAULIC CLUTCH LINES

TCL6001	60-62	Hydraulic Clutch Line - OS Steel
TCL6001S	60-62	Hydraulic Clutch Line - Stainless

FRONT BRAKE LINES

Front brake line kits consist of all brake lines under the hood including the master cylinder to the distribution, combination or metering valve, & left/right front lines that run to the front flex hoses. Designed for factory brake systems. If you have a disc conversion or aftermarket valve, call us for the correct line set.

ADD "S" TO PART NUMBER FOR STAINLESS STEEL

TKT6801 ...	67-70 ...	Manual Drum, 2 WD, 1/2 Ton & 3/4 Ton, Inside Frame.....	6 Pcs.
TKT6802 ...	67-70 ...	Power Drum, 2 WD, 1/2 Ton & 3/4 Ton, Inside Frame.....	6 Pcs.
TKT6901 ...	69-70 ...	Manual Drum, 2 WD, 1/2 Ton & 3/4 Ton, Outside Frame.....	6 Pcs.
TKT7002 ...	69-70 ...	Power Drum, 2 WD, 1/2 Ton & 3/4 Ton, Outside Frame.....	6 Pcs.
TKT6902	70	Longhorn Only	6 Pcs.
TKT7104 ...	71-72 ...	Man. Disc, 2 WD, 1/2 Ton	7 Pcs.
TKT7105 ...	71-72 ...	Power Disc, 2 WD, 1/2 Ton	7 Pcs.
TKT7106 ...	71-72 ...	Power Disc, 4 Wheel Dr. with 6' or 8' Bed, 1/2 & 3/4 Ton	7 Pcs.
TKT7107 ...	71-72 ...	Power Disc, 2 WD, 3/4 Ton	7 Pcs.
TKT7204 ...	71-72 ...	Blazer/Jimmy, Power Disc, 4 WD., 1/2 & 3/4 Ton	7 Pcs.

MAIN FUEL LINES

Main lines carry fuel from the tank in the rear of the car to the fuel pump or rail in the front. Designed to factory specifications. Multiple piece sets are noted. Call for 1/2" lines.

ADD "S" TO PART NUMBER FOR STAINLESS STEEL

TGL6804 ..	67-69 ...	3/8" 6' Bed
TGL6805 ..	67-69 ...	Main Line, 6 Cyl, 3/4 Ton
TGL6901	69	5/16" 8' Bed, 1/2 Ton
TGL7001	70	3/8" 6' Bed
TGL7002	70	1/4" 6' Bed, Return
TGL7003	70	3/8" Longhorn
TGL7101 ..	71-72 ...	1/4" 8' Bed, Return, 2 WD
TGL7102 ..	71-72 ...	3/8" 8' Bed, 4 WD
TGL7103 ..	71-72 ...	5/16" 8' Bed, Vapor, 2 WD
TGL7104 ..	71-72 ...	3/8" 8' Bed, 2 WD
TGL7106 ..	71-72 ...	3/8" Blazer, 4 WD
TGL7109 ..	71-72 ...	6' Bed, Stepside, 2 WD
TGL7110 ..	71-72 ...	5/16" 6' Bed, Vapor Line

VACUUM LINES

TDV6905

ADD "S" TO PART NUMBER FOR STAINLESS STEEL

TDV6702 ..	67-70 ...	Distributor Vacuum, SB with 2 BBL
TTV6905 ..	69-70 ...	Transmission Vacuum, T 350 & T 400
TTV7201	72	Chevy 1/2 Ton, 307 ci, TH350

FRONT TO REAR BRAKE LINES

Front to rear brake lines go from the distribution, combination or metering valve along the length of the vehicle to the rear flex hose. Manufactured in 1 or 2 pieces based on factory specifications.



ADD "S" TO PART NUMBER FOR STAINLESS STEEL

- TIN6801... 67-72 ... 2 WD, 6' Bed, Coil, 1/2-3/4 Ton
- TIN6808... 67-72 ... 8' Bed, Coil, 2WD
- TIN7201... 67-72 ... 2 WD, 6' Bed, Leaf, Stepside
- TIN7001.....70 K20, 4WD, 8' Bed, Leaf Spring
- TIN7101... 71-72 ... 2 WD, 8' Bed, Leaf, 1/2 & 3/4, 2-Pcs.
- TIN7102.....71 2 WD, 6' Bed, Coil, 1/2 & 3/4
- TIN7103... 71-72 ... 2 Wheel Drive, 8' Bed, Coil, 2-Pcs.
- TIN7104... 71-72 ... 4 Wheel Drive, 8' Bed
- TIN7105... 71-72 ... 4 Wheel Drive, Blazer
- TIN7106... 71-72 ... 2 WD, 6' Bed, Leaf, 1/2 & 3/4, 2 Pcs.
- TIN7204... 71-72 ... 4 Wheel Drive, Jimmy
- TIN7205... 71-72 ... 4 Wheel Drive, 6' Bed

TRANSMISSION COOLER LINES

Transmission cooler lines are sold as pairs. Be sure to verify the type of transmission in your project before ordering. These lines are intended to work only with factory motor, transmission, and radiator combinations.

TTC6772

ADD "S" TO PART NUMBER FOR STAINLESS STEEL

- TTC6704 ...67-69... with Turbo 350 & 400
- TTC6772 ...67-72... with 700R4
- TTC6803 ...70-72... with Turbo 350 & 400
- CTC7201 72 with TH-400 & 8.5 Spacing @ Radiator

REAR AXLE BRAKE LINES

Rear axle brake lines include a pair of lines that run across the rear axle housing. These lines connect the wheel cylinders or calipers to the flex hose in the middle of the rear end. These lines work with original housings that use factory brakes. Modifications such as rear disc brakes or narrowed rear ends will likely require special lines. Call for more information.

ADD "S" TO PART NUMBER FOR STAINLESS STEEL

- TRA6801 67-706 Lug, 1/2 Ton Coil
- TRA6803 67-703/4 Ton
- TRA6804 67-70Eaton Coil Rear
- TRA700270Longhorn with Dana
- TRA701170K20, 4 WD, 3/4 Ton, 8' Bed, Leaf
- TRA7102 71-721/2 Ton, 2 WD
- TRA7103 71-724 Wheel Drive, Standard Duty
- TRA7104 71-724 Wheel Drive with Dana
- TRA7105 71-72with Coil & Aux. Rear Leafs
- TRA7106 71-722 Wheel Drive, Heavy Duty
- TRA7234723/4 Ton, K-20, Leafspring

FRONT BRAKE FLEX HOSES

Front flex hoses provide a flexible connection from the body or frame to the front calipers or wheel cylinders as they move during suspension travel. Hoses are available in O.E. rubber. Hoses are D.O.T. approved & sold each.

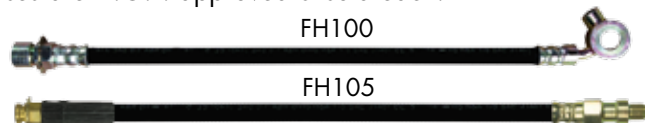

- FH117..... 38-50..... 1/2-Ton All
- FH122..... 67 1/2-Ton P10 or C10
- FH122..... 67 3/4-Ton C20
- FH109..... 68 1/2-Ton P10 or C10
- FH109..... 68 3/4-Ton C20
- FH105..... 69-70..... 1/2-Ton P10, C10
- FH105..... 69-70..... 3/4-Ton C20
- FH100..... 71-72..... 1/2-Ton Left, Disc
- FH101..... 71-72..... 1/2-Ton Right, Disc
- FH191..... 71-72..... 3/4-Ton Left Front Disc
- FH192..... 71-72..... 3/4-Ton Right Front Disc

REAR BRAKE FLEX HOSES

Rear flex hoses carry brake fluid between the body of the car and the rear. Hoses are available in O.E. rubber. 'T' blocks are attached whenever factory correct. All of our hoses are D.O.T. approved. Prices are per hose.

- FH127.....67 1/2-Ton K10
- FH103.... 67-70 1/2-Ton P10 or C10 with Coil Springs
- FH103.....67 3/4-Ton 67 C20 with Coil Springs
- FH131.....67 3/4-Ton 67 C20 with Leaf Springs
- FH131.... 68-70 1/2-Ton C10 with Leaf Springs
- FH103.... 68-69 3/4-Ton C20 with Small Block & Leaf Springs
- FH131.... 68-69 3/4-Ton Shortbed with Big Block & Coil Springs
- FH112.... 69-70 1/2-Ton Small Block with Left Spring
- FH104.....70 3/4-Ton C20 with Longbed & Aux. Fuel Tank
- FH103.....70 3/4-Ton C20 Shortbed with SB & Coil Springs
- FH131.....70 3/4-Ton C20 with Big Block & Leaf Springs
- FH104.... 71-72 1/2-Ton with Leaf Springs
- FH132.... 71-72 1/2-Ton with Coil Springs
- FH104.....71 3/4-Ton C20 with Leaf Springs
- FH105.....72 3/4-Ton C20 with Shortbed

WHEEL CYLINDERS

Wheel cylinders are priced individually. Hardware is not included.



- WC34.... 67-69K10, Left Front
- WC35.... 67-69K10, Right Front
- WC11.... 66-70Rear, C10, K10, P10, Left Rear
- WC12.... 66-70Rear, C10, K10, P10, Right Rear
- WC44.... 69-70C10 with Heavy Duty Brakes, Left Front
- WC45.... 69-70C10 with Heavy Duty Brakes, Right Front
- WC11.... 71-72Rear, All, Left Rear
- WC12.... 71-72Rear, All, Right Rear

FUEL PUMP TO CARB LINES

Fuel pump to carburetor lines connect the fuel pump to the carburetor. Brass blocks and fittings are included as noted. These lines are intended to work only with factory pump, motor, intake and carburetor combinations.



ADD "S" TO PART NUMBER FOR STAINLESS STEEL

- TPC670267-72..... 292, 6 Cylinder
- TPC6801 68 350, 4 BBL Rochester
- TPC690269-70..... 307 with 2 BBL, 5/16"
- TPC7002 70 350 with Quadrajct
- TPC710171-72..... 350 with Quadrajct
- TPC710471-72..... 402 ci. Short Pump
- TPC720171-72..... 402 ci. 4 BBL, Long Pump

FUEL PUMP TO CARB LINES

Fuel pump to carburetor lines connect the fuel pump to the carburetor. Brass blocks and fittings are included as noted. These lines are intended to work only with factory pump, motor, intake and carburetor combinations.

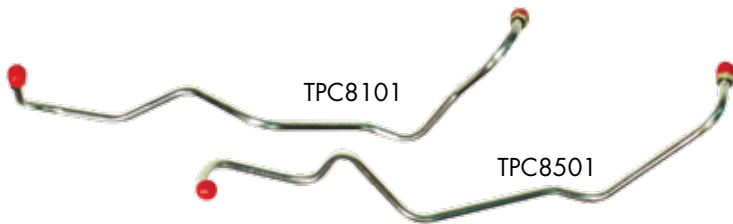

- TPC730173-80.....350 with Quadrajct/Blazer - OE Steel
- TPC7301S ...73-80.....350 with Quadrajct/Blazer - Stainless
- TPC7901 79350, 2 BBL - OE Steel
- TPC7901S 79350, 2 BBL - Stainless
- TPC810181-87.....350, with Quadrajct - OE Steel
- TPC8101S ...81-87.....350, with Quadrajct - Stainless
- TPC850186-87.....S-10, 2.8 Liter - OE Steel
- TPC8501S ...86-87.....S-10, 2.8 Liter - Stainless
- TPC865484-86.....454, Quadrajct - OE Steel
- TPC8654S ...84-86.....454, Quadrajct - Stainless
- TPC8504 85350, Quadrajct - OE Steel
- TPC8504S 85350, Quadrajct - Stainless

POWER STEERING LINES

Fuel tank vent lines allow the air inside the fuel tank to escape as it is filled with fuel. They also prevent pressure from building up due to temperature changes.

- TFV8701 874WD, V-10 Longbed - OE Steel
- TFV8701S..... 874WD, V-10 Longbed - Stainless
- TFV9301 931500, 2WD Full Size - OE Steel
- TFV9301S..... 931500, 2WD Full Size - Stainless
- TFV9503 952500, 4WD, 8' Bed - OE Steel
- TFV9503S..... 952500, 4WD, 8' Bed - Stainless

FRONT TO REAR BRAKE LINES

Front to rear brake lines go from the distribution, combination or metering valve along the length of the vehicle to the rear flex hose. Made in 1 or 2 pieces based on factory specifications.

ADD "S" TO PART NUMBER FOR STAINLESS STEEL

- TIN7302 73..... 3/4 Ton Crew Cab 2 Pcs.
- TIN7701 ...73-80 ... 2 WD, 8' Bed, 1/2-3/4 Ton
- TIN7702 ...73-80 ... Shortbed, Power Disc, 2 WD,
1/2 & 3/4 Ton..... 2 Pcs.
- TIN7401 ...74-77 ... 4 WD, 6' Bed..... 2 Pcs.
- TIN7703 ...77-80 ... Blazer, 4 Whl. Dr, Power Disc... 2 Pcs.
- TIN8004 ...77-80 ... 4 WD, 8' Bed..... 2 Pcs.
- TIN8005 80..... Suburban, 4 WD
- TIN8101 ...81-88 ... Shortbed, 1/2-3/4 2 WD..... 2 Pcs.
- TIN8102 ...81-88 ... Longbed, 2 WD..... 2 Pcs.
- TIN8104 ...81-88 ... Longbed, 4 WD..... 2 Pcs.
- TIN8105 ...81-88 ... Shortbed, 1/2 Ton, 4WD 2 Pcs.
- TIN8601 ...81-88 ... Longbed, 4 WD, Equalizer 3 Pcs.
- TIN8402 84..... Sonoma, 2WD 2 Pcs.
- TIN8505 85..... S-10, E. Cab, 4WD, Shortbed... 2 Pcs.
- TIN8701 87..... 4 WD V-10 Longbed 2 Pcs.
- TIN8901 89..... S-10, 4 WD
- TIN8902 89..... 2 WD, Shortbed 2 Pcs.
- TIN8903 89..... Longbed, 4 WD..... 2 Pcs.
- TIN8904 89..... 1/2 Ton, 4WD, Longbed..... 2 Pcs.
- TIN8905 89..... 1/2 Ton, 4WD, Shortbed 2 Pcs.
- TIN9001 90..... S-10, Shortbed
- TIN9101 91..... Longbed, S-10, 2 WD
- TIN9201 ...91-92 ... 8' Bed, 2 WD, 1/2-3/4 Ton 2 Pcs.
- TIN9204 ...92-94 ... Blazer/Yukon, 4WD..... 2 Pcs.
- TIN9305 93 Astro Van, Disc/Drum
- TIN9401 94..... 3500 Crewcab Longbed Disc... 2 Pcs.
- TIN9502 95..... S10 Xtra Cab, Short Bed 2 Pcs.
- TIN9503 95..... 2500, 4WD, 8' Bed
- TIN9507 ...95-98 ... 1500, WD, Ext. Cab..... 2 Pcs.
- TIN9601 96..... 3/4 Ton, Longbed, 4x4, 8 Lug
- TIN9703 97..... 1/2 Ton, Longbed, 2 WD..... 2 Pcs.
- TIN9704 97..... GMC Dually, 2 pcs.
- TIN9902 99..... 3/4 Ton Suburban 2 Pcs.
- TIN2006 ...99-06 ... 1/2 Ton, 4WD Ext. Cab, shortbed
- TIN2001 00..... 1/2 Ton, 8' Bed
- TIN0101 01..... 3/4 Ton, 4WD, Longbed, ABS
- TIN2008 01..... S-10 Jimmy
- TIN9020 ...99-02 ... 1/2 Ton, Short Bed, Reg. Cab
- TIN0201 ...99-02 ... 1 Ton, 8' Bed, Crew Cab
- TIN2003 02..... Avalanche Z71 ABS Disc
- TIN2036 ...03-06 ... 3/4 Ton, 4 WD, ABS
- TIN0301 ...03-06 ... 1/2 Ton, Longbed, 4WD, Reg.
- TIN0404 ...03-06 ... 3/4-1 Ton, 4WD, Crew Cab, Longbed
- TIN0405 04..... S-10 Blazer ZR2. V6, 2d, 4WD. 3 Pcs.

FUEL TANK VENT LINES

Vent lines allow the air inside the fuel tank to escape as it is filled with fuel & prevent pressure when the temperature changes.

- TFV710171-72... Tank Vent Line - OE Steel
- TFV7101S....71-72... Tank Vent Line - Stainless

FRONT BRAKE LINE KITS

Front brake line kits consist of all brake lines under the hood. This includes the master cylinder to the distribution, combination or metering valve. The left and right front lines that run to the front flex hoses are also included. Call for individual component pricing. For vehicles with factory brake systems.

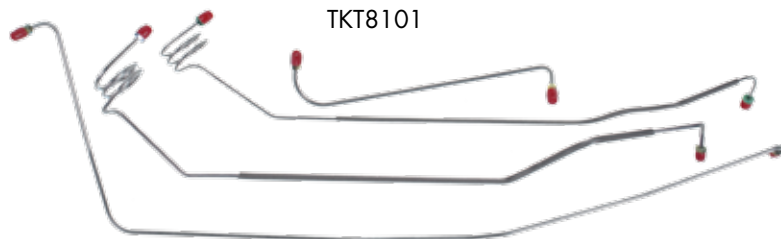

ADD "S" TO PART NUMBER FOR STAINLESS STEEL

TKT7302 73 3/4 Ton Crew Cab, Pwr. Disc	...4 Pcs.
TKT7301	... 73-76	... 2 WD, Pwr. Disc, 1/2 or 3/4	...4 Pcs.
TKT7701	... 73-80	... 2 WD, Pwr. Disc, 1/2 or 3/4	...4 Pcs.
TKT7401	... 74-77	... 4 WD4 Pcs.
TKT7703	... 77-80	... Blazer, 4 WD, Power Disc4 Pcs.
TKT8004	... 78-80	... 4 WD, Power Disc4 Pcs.
TKT8101	... 81-87	... Power Disc, 1/2-3/4 Ton4 Pcs.
TKT8104	... 81-88	... 1/2-3/4 Blazer/Jimmy/Truck, Power Disc, 4 WD4 Pcs.
TKT8401 84 S-104 Pcs.
TKT8402 84 Sonoma 2WD, Disc/Drum5 Pcs.
TKT8505 85 S-104 Pcs.
TKT8704 87 1/2 Ton, 4 WD, JBS System4 Pcs.
TKT8701 87 4WD Longbed4 Pcs.
TKT8804	... 88-89	... 3500 Series 2 WD with ABS7 Pcs.
TKT8901 89 S-10, Power Disc5 Pcs.
TKT8903 89 1/2 Ton, 4WD, ABS7 Pcs.
TKT8905 89 1/2 Ton, 4 WD, Power Disc7 Pcs.
TKT8906 89 3500. 4WD4 Pcs.
TKT9002 90 3/4 Ton, 8 Lug with ABS, 4WD, C6P7 Pcs.
TKT9001 90 1500 Silverado Disc Brakes7 Pcs.
TKT9003	... 90-94	... Silverado SS, 454, 2WD, 12-Bolt6 Pcs.
TKT9101 91 S-10 Power Disc, 2 WD7 Pcs.
TKT9201 92 Pwr. Disc with ABS, 1/2 - 3/4	...7 Pcs.
TKT9202 92 Sonoma4 Pcs.
TBS9202 92 Sonoma Disc Full Brake Set10 Pcs
TKT9204	... 92-94	... Blazer/Yukon, 4WD8 Pcs.
TKT9301 93 1500 2WD Fullsize7 Pcs.
TKT9303 93 GMC Sierra 3500 SLE, 4WD, 6.5L, Turbo Diesel, Crew Cab, 8' Bed, Dually7 Pcs.
TKT9401 94 3500 Hydro Boost Drum6 Pcs.
TKT9502 95 S10, Xtra Cab, Short Bed7 Pcs.
TKT9503 95 Pwr. Disc, 2500, 4WD, 8' Bed	...6 Pcs.
TKT9601 96 S10 Blazer 4.3L, 4WD Disc/Drum5 Pcs.
TKT9507	... 95-98	... 1500, 4WD, Ext. Cab6 Pcs.

FRONT BRAKE FLEX HOSES

Front flex hoses provide a flexible connection from the body or frame to the front calipers or wheel cylinders as they move during suspension travel. O.E. rubber or braided stainless steel. All of our hoses are D.O.T. approved. Hoses are priced individually.

FH102 73-78 1/2-Ton K10, Left or Right
FH106 73-78 1/2-Ton C10 or P10, Right
FH107 73-78 1/2-Ton C10 or P10, Left
FH108 73-86 3/4-Ton C20 or K20
FH108 73-90 3/4-Ton P20
FH123 79-80 1/2-Ton Left
FH125 79-80 1/2-Ton Right
FH123 81-86 1/2-Ton with Diesel, Left
FH125 81-86 1/2-Ton with Diesel, Right
FH136 90-94 1/2-Ton Silverado SS, Left
FH137 81-86 1/2-Ton without Diesel, Right
FH138 81-86 1/2-Ton without Diesel, Left
FH139 88-90 1/2-Ton with 7200 Lb. GVW, Left
FH140 88-90 1/2-Ton with 7200 Lb., GVW, Right
FH136 88-91 3/4-Ton C20 or K20
FH140 90-94 1/2-Ton Silverado SS, Right
FH0401 04 1/2-Ton Left
FH0401S 04 1/2-Ton Left - Stainless
FH0402 04 1/2-Ton Right
FH0402S 04 1/2-Ton Right - Stainless

REAR BRAKE FLEX HOSES

Rear flex hoses carry brake fluid between the body of the car and the rear. Hoses are available in O.E. rubber. 'T' blocks are attached whenever factory correct. All of our hoses are D.O.T. approved. Prices are per hose.

FH102 73-78 3/4-Ton K20, Left or Right
FH106 73-78 3/4-Ton Except K Series, Right
FH108 74-86 1/2-Ton without 11,000Lb. Rear Axle
FH107 73-78 3/4-Ton Except K Series, Left
FH151 79-80 3/4-Ton K20, 13 x 2.50", Brakes, Left or Right
FH152 79-80 3/4-Ton K20, 11.15 x 2.75" Bks, Left or Right
FH123 79-86 3/4-Ton C20, Left
FH125 79-86 3/4-Ton C20, Right
FH150 79-86 3/4-Ton C20, 13 x 2.50" Brakes, Right
FH142 81-86 K20, 2D with 11.15 x 2.75" Brakes, Left
FH143 81-86 K20, 2D with 11.15 x 2.75" Brakes, Right
FH153 81-86 K20, Suburban, 2D, 13 x 2.50" Brakes, Left
FH154 81-86 K20, Suburban, 2D 13 x 2.50" Bks, Right
FH144 88 3/4-Ton K20, Left
FH145 88 3/4-Ton K20, Right
FH139 88-92 3/4-Ton C20, 7200 Lb. GVW, Left
FH140 88-92 3/4-Ton C20, 7200 Lb. GVW, Right
FH146 89-90 3/4-Ton K20, 8600 Lb. GVW
FH147 89-90 3/4-Ton K20 8600 Lb. GVW
FH136 88-91 1/2-Ton All
FH136 90-94 1/2-Ton Silverado SS
FH0403 04 1/2-Ton Left & Right
FH0403S	... 04 1/2-Ton Left & Right - Stainless
FH0404 04 1/2-Ton Rear Differential
FH0404S	... 04 1/2-Ton Rear Differential - Stainless

REAR AXLE BRAKE LINES

Rear axle brake lines include a pair of lines that run across the rear axle housing. These lines connect the wheel cylinders or calipers to the flex hose in the middle of the rear end. These lines work with original housings that use factory brakes. Modifications such as rear disc brakes or narrowed rear ends will likely require special lines. Call for more information.

ADD "S" TO PART NUMBER FOR STAINLESS STEEL

TRA730273 3/4 Ton
 TRA7702 .. 73-80 ... 1/2 Ton, Standard Duty
 TRA7401 .. 74-77 ... 4 WD, Standard Duty
 TRA773077 1 Ton, 14 Bolt, K30
 TRA780478 1/2 Ton 4WD
 TRA790479 1 Ton
 TRA800480 4 WD
 TRA8101 .. 81-87 ... Standard Rear, 1/2 Ton, 5 Lug
 TRA8103 .. 81-87 ... Dually
 TRA8104 .. 79-87 ... Blazer/Jimmy, 4WD
 TRA850485 3/4 Ton, WD
 TRA850585 S-10
 TRA9101 .. 87-91 ... S-10, Standard Duty, 2WD
 TRA880488 1/2 Ton, 4 WD
 TRA890189 S-10, 4 WD
 TRA890389 1/2 Ton, 4WD
 TRA890589 10 Bolt, Leaf
 TRA9003 .. 90-94 ... Silverado SS, 454, 2WD, 12 Bolt
 TRA910391 1/2 Ton, 2WD
 TRA920192 1/2 Ton, Standard Duty
 TRA920292 Sonoma
 TRA920692 Typhoon
 TRA9204 .. 92-94 ... Blazer/Yukon, 4WD, 2-Piece
 TRA930193 S-10 Blazer
 TRA930393 S-10 Shortbed
 TRA930493 Suburban
 TRA930593 1500 Fullsize
 TRA930793 GMC Sierra 3500 SLE, 4WD, 6.5L, Turbo Diesel,
 Crew Cab, 8' Bed Dually, 2-Piece
 TRA940194 3500 Longbed
 TRA950295 S10, Rear Disc, 2-Piece
 TRA950395 2500, 4WD, 8' Bed, Axle Pair
 TRA950595 S10, Rear Drum, 2-Piece
 TRA9507 .. 95-98 ... 1500, 4WD
 FTRA9601 ...96 3/4 Ton, 4x4, 8 Lug
 TRA960296 1 Ton Dually
 TRA200100 2or 4WD, 4 Wheel Disc
 TRA010101 3/4, 4WD, ABS
 TRA200801 S-10, Jimmy, 2-Piece
 TRA9020 .. 99-02 ... 1/2 Ton, 4 WD
 TRA0201 .. 99-02 ... 1 Ton, 4 WD
 TRA200302 Avalanche Z71 Disc Rear Axle Line
 TRA2036 .. 03-06 ... 3/4 Ton, 4 WD, ABS, 4W Disc, 2-Piece
 TRA0301 .. 03-06 ... 1/2 Ton, 4WD, ABS, 4 Wheel Disc
 TRA0404 .. 03-06 ... Axle Tube Block
 TRA040504 S-10 Blazer ZR2, V6, 2-Door, 4WD

TRANSMISSION COOLER LINES

Transmission cooler lines are sold as pairs. Be sure to verify the type of transmission in your project before ordering. These lines are intended to work only with factory motor, transmission, and radiator combinations.

ADD "S" TO PART NUMBER FOR STAINLESS STEEL

TTC750373-80 with TH-350
 TTC770377-80 Blazer with TH-350
 TTC810381-87 with TH-350
 TTC810481-87 Blazer/Jimmy, 4WD, with TH-350
 TTC830181-87 305, 2WD, 700 R4, 2-Piece.
 TTC850481-87 4 WD, T-400
 TTC8505 85 C35, 2WD, T-400
 TTC8509 85 Cabellaro, 4.3L
 TTC8607 86 4x4 Suburban with 700 R4
 TTC880588-89 1 Ton, TH-400
 TTC880388-90 Blazer, 4 WD, V6
 TTC8901 89 Van G20 700 5.0L
 TTC8904 89 Truck/Sub 350, 700-R4, 2-Piece.
 TTC900390-94 Silverado SS, 454, 2WD, T-400
 TTC9004 90 Astro Van, 4.3 with 700-R4
 TTC9102 91 K5 Blazer, 350, 700R, 2-Piece.
 TTC9103 91 1/2 Ton, 4 WD, 700-R4
 TTC9201 92 Sonoma 4.3L, 2WD
 TTC9304 93 1 Ton, 4WD
 TTC9305 93 4L8E Transmission

TRANSMISSION VACUUM LINES

Transmission vacuum lines connect automatic transmissions to intake vacuum.

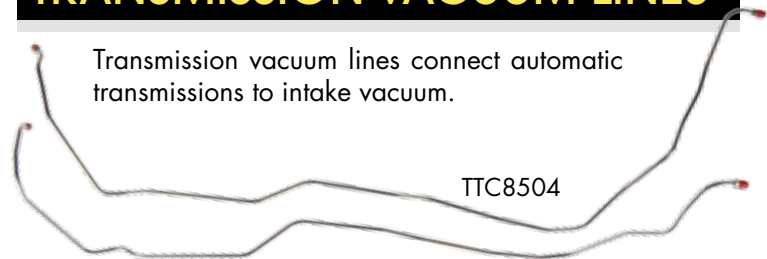

TTV8504 85 TH-400, 4 WD
 TTV7901 ... 79-80 TH-350, 350ci
 TTV9003 ... 90-94 TH-400, Silverado SS, 454, 2WD
 TTV8704 ... 87-95 TH-400, 4 WD

WHEEL CYLINDERS

Wheel cylinders are priced individually. Hardware is not included.



WC1173 Left
 WC1273 Right
 WC19 74-75 P10
 WC19 74-78 C10 or K10 with 11x 2" Brakes
 WC50 74-86 All except 11 x 2" Brakes
 WC55 85-86 C10 with 11 x 2" Brakes
 WC52 88-90 with 9.50" Ring Gear
 WC53 88-90 with 11 x 2" Brakes
 WC54 88-90 with 11.15 x 2.75" Brakes

1973-94 CHEVY/GM TRUCK

FUEL LINES

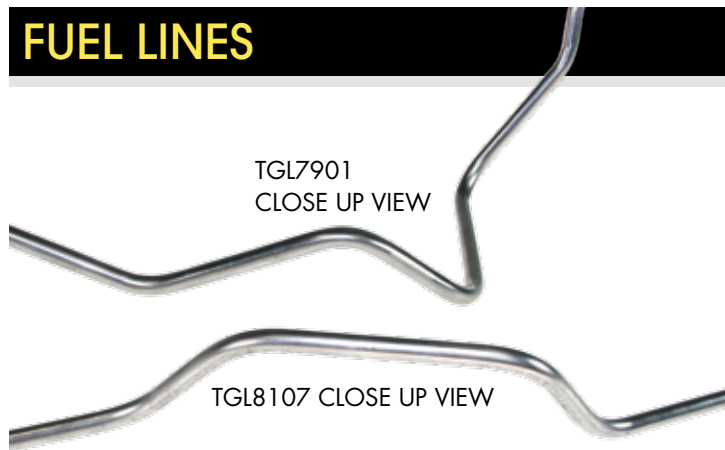

ADD "S" TO PART NUMBER FOR STAINLESS STEEL

TGL7401 ..73-80...6' Bed, 4x4, 3/8" Main, 2-Piece.
 TGL7701 ..73-80...8' Bed, 3/8", 1/2-3/4 Ton
 TGL7702 ..73-80...8' Bed, 1/4" Ret, 1/2-3/4 Ton
 TGL7703 ..73-80...5/16" Vapor, Main Tank, 1/2-3/4 Ton
 TGL7704 ..73-80...4 Door Crew Cab, 3/8", 2-Piece..
 TGL7705 ..73-80...4 Door Crew Cab, 1/4" Return, 2-Pc..
 TGL7706 ..73-80...4 WD, 8" Bed, 1/2-3/4, 3/8"
 TGL7707 ..73-80...4 WD, 8' Bed, 1/2-3/4 Ton,
 1/4" Return
 TGL7708 ..73-80...5/16" Vapor, Aux. Tank, 1/2-3/4 Ton
 TGL7709 ..73-80...6' Bed, 3/8"
 TGL7805 ..76-79...2 WD, Short Bed, 1/4" Return, 2-Pc.
 TGL7709 ..73-80...6' Bed, 3/8"
 TGL7710 ..73-80...6' Bed, 5/16"
 TGL771A..73-80...3/8", Dual Tank Jumper Line
 TGL790179.....5/16" Li'l Red Express Main Line, 2-Pc..
 TGL7904 ..79-80...4WD Blazer/Jimmy, 5/16" Vap, 2-Pc.
 TGL7905 ..79-80...4WD Blazer/Jimmy 1/4 Return, 2-Pc.
 TGL7906 ..79-80...4WD Blazer/Jimmy 3/8" Main, 2-Pc.
 TGL8101 ..81-87...8' Bed, 3/4, 5/16" Vapor Line
 TGL8102 ..81-87...4WD, Crew Cab, Dual Tank
 3/8" Main Fuel Line, 3-Piece.
 TGL8103 ..81-87...4WD, Crew Cab, Dual Tank,
 1/4" Return Line, 3-Piece.
 TGL8104 ..81-87...4WD, Blazer/Jimmy, 5/16" Vap, 2-Pc
 TGL8105 ..81-87...4WD, Blazer/Jimmy, 1/4" Return, 2-Pc
 TGL8106 ..81-87...4WD, Blazer/Jimmy, 3/8", 2-Piece
 TGL8107 ..81-87...4WD, 3/4 Ton, 3/8"
 TGL8108 ..81-87...4WD, 3/4 Ton, 1/4"
 TGL8187 ..81-87...3/4 Ton Dual Tank Crossover,
 1/4" Fuel Return Line, 2-Piece
 TGL8188 ..81-87 ..Chevy K20 3/4 Ton, Dual Tank,
 5/16" Vapor Line, 2-Piece
 TGL8189 ..81-87...Chevy K20 3/4 Ton, Dual Tank,
 3/8" Main Fuel Line, 2-Piece.
 TGL8301 ..81-87...3/8" Main, 1/2 Ton, 2-Piece

TGL8302 ..81-87...1/4" Return, 1/2 Ton, 2-Piece
 TGL830383.....5/16" Vapor, 1/2 Ton, 2-Piece
 TGL840184.....Sonoma 3/8" Main Line, 3-Piece
 TGL840284.....Sonoma 5/16" Return Line
 TGL8505 ..81-87...4 WD, Dual Tank, 3/8 Main, 2-Piece
 TGL8506 ..81-87...4 WD, Dual Tank, 1/4 Return, 2-Piece
 TGL850885.....1 Ton, 2WD, 5/16" Vapor Line
 TGL870187.....4WD V-10 Longbed, 3/8" Main, 2-Piece
 TGL870287.....4WD V-10 Longbed 1/4" Return
 TGL87DC .81-87...1/2-3/4 Ton 2WD or 4WD Dual Tank,
 Conversion Set, 5 pcs. 3 Crossover Lines,
 2 Transfer Pump Lines
 TGL890189.....S-10, O Ring Flair, 3-Piece
 TGL890289.....S-10, 5/16" Vapor Line
 TGL890389.....S-10, 1/4" Fuel Return
 TGL890589.....4WD, 8' Bed, 5/16" Vapor Lines, 2-Pc
 TGL9001 ..90-94...Silverado SS, F.I. 454, 2WD, 6' Bed, Regular
 Cab, 3/8" Main Line, 5-Piece
 TGL9002 ..90-94...Silverado SS, F.I. 454, 2WD, 6' Bed, Reg Cab,
 5/16" Return Line, 5-Piece
 TGL9003 ..90-94...Silverado SS, F.I. 454, 2WD, 6' Bed Vapor Line,
 2-Piece
 TGL920192.....Sonoma, 2WD, 3/8" Main Line, 4-Piece
 TGL920292.....Sonoma, 2WD 5/16" Return, 3-Piece
 TGL920392.....Sonoma, 2WD 1/4" Vapor Line
 TGL920592.....Typhoon, Vapor
 TGL930493.....Sierra 3500 SLE, 4WD, 6.5L, 8' Bed Turbo Diesel,
 Crew Cab, Dually, 3/8" Main Fuel Line,
 5-Piece
 TGL930593.....Sierra 3500 SLE, 4WD, 6.5L, 8' Bed Turbo Diesel,
 Crew Cab, Dually, 5/16" Return Line,
 5-Piece
 TGL9301 ..93-94...1500, 1/2 Ton 4WD, Standard Cab, 6 Bed,
 3/8" Main Fuel Line, 3-Piece
 TGL9302 ..93-94...1500, 1/2 Ton 4WD, Standard Cab, 6 Bed,
 5/16" Return Line, 3-Piece
 TGL9303 ..93-94...1500, 1/2 Ton 4WD, Standard Cab, 6 Bed,
 1/4" Vapor Line, 2-Piece
 TGL9234 ..92-94...Blazer/Yukon, 4WD, 3/8", 3-Piece
 TGL9244 ..92-94...Blazer/Yukon, 4WD, 1/4", 3-Piece
 TGL940194.....3500 CrewCab, Longbed 3/8", 3-Pc
 TGL940294.....3500 CrewCab, Longbed 5/16", 3-Pc

POWER STEERING LINES

Power steering lines can be either pressure or return feeds in a power steering system.

TPS9201.....92-93.....GMC Typhoon - OE Steel
 TPS9201S....92-93.....GMC Typhoon - Stainless



AVALANCHE 1500 BRAKE LINES

ADD "S" TO PART NUMBER FOR STAINLESS STEEL

- TBS319702 HYD Power 4WD 9000 lbs.
- TBS321802 Vac Power 4WD 7200 lbs
- TBS2003 .. 03-06 ... with Traction Control Includes All Lines
Except Rear Axle, Pair
- TBS2592 .. 03-06 ... HYD power Disc/Disc with Front
Vented Rotors

ESCALADE BRAKE LINES

ADD "S" TO PART NUMBER FOR STAINLESS STEEL

- TBS321802 EXT Vac power 4 Wheel Disc AWD
- TBS2519 .. 03-06 ... Vac Power Disc/Disc RWD
- TBS2593 .. 03-06 ... Vac Power Disc/Disc AWD
- TBS2594 .. 03-06 ... Vac Power Disc/Disc RWD
- TBS3216 .. 03-06 ... HYD Power 4 Wheel Disc AWD
- TBS2592 .. 03-06 ... EXT HYD Power Disc/Disc

SIERRA 1500 BRAKE LINES

ADD "S" TO PART NUMBER FOR STAINLESS STEEL

- TBS3207 .. 99-02 ... Vac Power 4 Wheel Disc RWD
- TBS3208 .. 99-02 ... Vac Power 4 Wheel Disc 4WD
- TBS3210 .. 99-02 ... EXT Vac Power 4 Wheel Disc RWD
- TBS3211 .. 99-02 ... EXT Vac Power 4 Wheel Disc 4WD
- TBS3212 .. 99-02 ... EXT Vac Power 4 Wheel Disc RWD
- TBS3213 .. 99-02 ... Vac Power 4 Whl Disc RWD
- TBS3214 .. 99-02 ... EXT Vac Power 4 Wheel Disc 4WD
- TBS3215 .. 99-02 ... Crew Vac Power 4 Wheel Disc 4WD
- TBS2590 .. 04-05 ... Vac Power Disc/Disc 4WD
- TBS2595 .. 05-07 ... EXT Vac Power 17" Disc/Drum RWD
- TBS2596 .. 05-07 ... EXT HO Engine Package with Enhanced
Towing Pkg RWD
- TBS2597 .. 05-07 ... Crew Vac Power Disc/Drum 4WD
- TBS2598 .. 05-07 ... Vac Pwr Disc/Drum with RWAL 4WD
- TBS2599 .. 05-07 ... EXT Vac Pwr Disc/Disc with RWAL 4WD
- TBS2600 .. 05-07 ... EXT Vac Power Disc/Drum w/RWAL 4WD
- TBS2601 .. 05-07 ... EXT HO Engine Pkg with Enhanced
Towing Package RWD
- TBS2602 .. 05-07 ... Crew HO Engine Pkg with Enhanced
Towing Package RWD
- TBS2603 .. 05-07 ... Vac Pwr Disc/Drum with RWAL RWD
- TBS2604 .. 05-07 ... EXT Vac Pwr Disc/Drum RWD
- TBS2609 .. 05-07 ... Vac Power Disc/Drum with RWAL RWD

SIERRA 1500 HD BRAKE LINES

ADD "S" TO PART NUMBER FOR STAINLESS STEEL

- TBS3209 .. 01-02 ... Crew HYD Power 4 WHL Disc
- TBS 2605 . 03-07 ... Crew HYD Power 4 WHL Disc
- TBS2590 .. 06-07 ... Crew Vac Pwr Disc/Disc 4WD

SIERRA 2500 BRAKE LINES

ADD "S" TO PART NUMBER FOR STAINLESS STEEL

- TBS3193 .. 99-00 ... EXT HYD Power 4 Wheel Disc
- TBS3194 .. 99-02 ... HYD Power 4 Wheel Disc
- TBS3203 .. 99-00 ... HYD Power 4 Wheel Disc
- TBS3204 .. 99-00 ... EXT HYD Power 4 Wheel Disc
- TBS3205 .. 99-00 ... EXT HYD Power 4 Wheel Disc

SIERRA 2500 HD BRAKE LINES

ADD "S" TO PART NUMBER FOR STAINLESS STEEL

- TBS3187 ...01-07... Crew HYD Power 4 Wheel Disc
- TBS3188 ...01-02... EXT HYD Power 4 Wheel Disc
- TBS3189 ...01-02... HYD Power 4 Wheel Disc
- TBS3190 ...01-02... Crew HYD Power 4 Wheel Disc
- TBS3191 ...01-02... EXT HYD Power 4 Wheel Disc
- TBS2578 ...03-04... EXT HYD Power 4 Wheel Disc 4WD
- TBS2579 ...03-04... HYD Power 4 Wheel Disc RWD
- TBS2567 ...03-07... HYD Power 4 Wheel Disc
- TBS2568 ...03-07... Crew HYD Power 4 Wheel Disc
- TBS2569 ...03-07... EXT HYD Power 4 Wheel Disc
- TBS2574 ...03-07... EXT HYD Power 4 Wheel Disc
- TBS2565 ...03-07... EXT HYD Power 4 Wheel Disc

SIERRA 3500 BRAKE LINES

ADD "S" TO PART NUMBER FOR STAINLESS STEEL

- TBS3189 ...01-02... HYD Power 4 Wheel Disc
- TBS3190 ...01-02... Crew HYD Power 4 Wheel Disc
- TBS3198 ...01-02... HYD Power 4 Wheel Disc RWD
- TBS3199 ...01-02... Vac Power Disc/Drum with RWAL
- TBS3200 ...01-02... HYD Power 4 Wheel Disc
- TBS2570 ...03-07... HYD Power 4 Wheel Disc
- TBS2571 ...03-07... EXT HYD Power 4 Wheel Disc
- TBS2576 ...03-07... HYD Power 4 Wheel Disc



SILVERADO 1500 BRAKE LINES

ADD "S" TO PART NUMBER FOR STAINLESS STEEL

TBS3207 ... 99-02 ... Vac Power 4 Wheel Disc RWD
TBS3208 ... 99-02 ... HYD Power 4 Wheel Disc 4WD
TBS3210 ... 99-02 ... EXT Vac Power 4 Wheel Disc RWD
TBS3211 ... 99-02 ... EXT Vac Power 4 Wheel Disc 4WD
TBS3212 ... 99-02 ... EXT Vac Power 4 Wheel Disc RWD
TBS3213 ... 99-02 ... Vac Power 4 Wheel Disc 4WD
TBS3214 ... 99-02 ... Vac Power 4 Wheel Disc RWD
TBS3215 ... 99-02 ... EXT Vac Power 4 Wheel Disc 4WD
TBS2583 ... 03-04 ... EXT Vac Power Disc/Disc 4WD
TBS2584 ... 03-04 ... Vac Power Disc/Disc RWD
TBS2585 ... 03-04 ... EXT Vac Power Disc/Disc RWD
TBS2586 ... 03-04 ... EXT Vac Power Disc/Disc 4WD
TBS2587 ... 03-07 ... EXT Vac Power Disc/Disc 4WD
TBS2588 ... 03-04 ... Vac Power Disc/Disc 4WD
TBS2589 ... 03-04 ... EXT Vac Power Disc/Disc 4WD
TBS2590 ... 04-06 ... Crew Vac Power Disc/Disc 4WD
TBS2595 ... 05-07 ... Vac Power Disc/Drum with RWAL 4WD
TBS2596 ... 05-07 ... EXT HO Engine Package with Enhanced Towing Package RWD
TBS2597 ... 05-07 ... Crew Vac Power Disc/Drum 4WD
TBS2598 ... 05-07 ... Vac Power Disc/Drum with RWAL 4WD
TBS2599 ... 05-07 ... EXT W/Rear Wheel ABS 4 WD
TBS2600 ... 05-07 ... EXT Vac Pwr Disc/Drum w/RWAL 4WD
TBS2601 ... 05-07 ... EXT Vac Pwr Disc/Drum HO Engine Package with RWAL with Enhanced Towing Package RWD
TBS2602 ... 05-07 ... Crew Vac Pwr Disc/Drum HO Engine Package with RWAL with Enhanced Towing Pkg RWD
TBS2603 ... 05-07 ... Vac Power Disc/Drum with RWAL RWD
TBS2604 ... 05-07 ... EXT Vac Power Disc/Drum w/RWAL RWD
TBS2609 ... 05-07 ... Vac Power Disc/Drum with RWAL RWD

SILVERADO 1500 HD BRAKE LINES

ADD "S" TO PART NUMBER FOR STAINLESS STEEL

TBS3209 ... 01-02 ... Crew HYD Power 4 Wheel Disc
TBS2590 ... 03-07 ... Crew Vac Power Disc/Disc
TBS2605 ... 03-07 ... Crew HYD Power 4 Wheel Disc

SILVERADO 2500 BRAKE LINES

ADD "S" TO PART NUMBER FOR STAINLESS STEEL

TBS3193 ... 99-00 ... EXT HYD Power 4 Wheel Disc 4WD
TBS3194 ... 99-02 ... HYD Power 4 Wheel Disc 4WD
TBS3202 ... 99-00 ... EXT HYD Power 4 Wheel Disc RWD
TBS3204 ... 99-00 ... EXT HYD Power 4 Wheel Disc RWD
TBS3205 ... 99-00 ... EXT HYD Power 4 Wheel Disc 4WD

SILVERADO 2500 HD BRAKE LINES

ADD "S" TO PART NUMBER FOR STAINLESS STEEL

TBS3188 ... 01-02 ... EXT HYD Power 4 Wheel Disc
TBS3189 ... 01-02 ... HYD Power 4 Wheel Disc
TBS3190 ... 01-02 ... Crew HYD Power 4 Wheel Disc
TBS3191 ... 01-02 ... EXT HYD Power 4 Wheel Disc
TBS3187 ... 03-07 ... Crew HYD Power 4 Wheel Disc

SILVERADO 3500 BRAKE LINES

ADD "S" TO PART NUMBER FOR STAINLESS STEEL

TBS3189 ... 01-02 ... HYD Power 4 Wheel Disc
TBS3190 ... 01-02 ... Crew HYD Power 4 Wheel Disc
TBS3198 ... 01-02 ... HYD Power 4 Wheel Disc 2WD/4WD
TBS3199 ... 01-02 ... Vac Power Disc/Drum with RWAL
TBS3200 ... 01-02 ... HYD Power 4 Wheel Disc
TBS2576 ... 03-07 ... HYD Power 4 Wheel Disc

SUBURBAN 1500 BRAKE LINES

ADD "S" TO PART NUMBER FOR STAINLESS STEEL

TBS3206 00 HYD Power 4 Wheel Disc RWD
TBS3219 ... 00-02 ... Vac Power 4 Wheel Disc RWD/4WD
TBS3197 ... 01-02 ... HYD Power 4 Wheel Disc
TBS2592 ... 03-06 ... Vac Power Disc/Disc 4WD
TBS2594 ... 03-06 ... Vac Power Disc/Disc RWD

SUBURBAN 2500 BRAKE LINES

ADD "S" TO PART NUMBER FOR STAINLESS STEEL

TBS2582 ... 03-06 ... HYD Power Disc/Disc 4 Wheel Anti-lock

TAHOE BRAKE LINES

ADD "S" TO PART NUMBER FOR STAINLESS STEEL

TBS3216 02 HYD Power 4 Wheel Disc 4WD
TBS3217 ... 00-02 ... Vac Power Disc/Disc RWD/4WD
TBS2591 ... 03-06 ... Vac Power Disc/Disc RWD/4WD
TBS2593 ... 03-06 ... HYD Power Disc/Disc RWD/4WD

YUKON BRAKE LINES

ADD "S" TO PART NUMBER FOR STAINLESS STEEL

TBS3206 00 HYD Poer 4 Wheel Disc RWD
TBS3197 ... 00-02 ... HYD Power 4 WHL Disc 4WD
TBS3216 ... 00-02 ... HYD Power 4 Wheel Disc RWD/4WD
TBS3217 ... 00-02 ... Vac Power 4 Wheel Disc RWD/4WD
TBS3219 ... 00-02 ... Vac Power 4 Wheel Disc RWD/4WD
TBS2592 ... 03-06 ... Vac Power Disc/Disc RWD
TBS2593 ... 03-06 ... Vac Power Disc/Disc RWD/4WD
TBS2594 ... 03-06 ... Vac Power Disc/Disc RWD/4WD

YUKON XL BRAKE LINES

ADD "S" TO PART NUMBER FOR STAINLESS STEEL

TBS3219 ... 00-02 ... Vac Power 4 Wheel Disc RWD/4WD
TBS2582 ... 03-06 ... HYD Power 4 Wheel Disc RWD/4WD
TBS2592 ... 03-06 ... Vac Power Disc/Disc 4WD
TBS2594 ... 03-06 ... Vac Power Disc/Disc RWD

FRONT TO REAR BRAKE LINES

Front to rear brake lines go from the distribution, combination or metering valve along the length of the vehicle to the rear flex hose. Manufactured in 1 or 2 pieces based on factory specifications.

ADD "S" TO PART NUMBER FOR STAINLESS STEEL

- FIN6701.....67..... Disc or Drum
- FIN6702.....67..... Disc Only, 2-Piece.
- FIN6801.....68..... Disc or Drum
- FIN6802.....68..... Disc Only, 2-Piece.
- FIN6901.....69..... Power
- FIN6902.....69..... Power, 2-Piece.
- FIN6903.....69..... Manual
- FIN7001.....70..... Power Disc
- FIN7103.....71-73 All

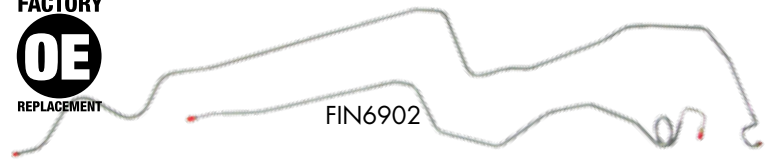

- FIN7401..... 74-75 Power Disc
- FIN7402..... 74-75 Trans-Am Only
- FIN7801..... 76-81 Power Disc
- FIN8201..... 82-83 4 & 6 Cylinder
- FIN8202..... 82-83 V-8
- FIN8401..... 84-85 4 & 6 Cylinder
- FIN8402..... 84-85 V-8
- FIN8601..... 86-92 All

FRONT BRAKE LINE KITS

Front brake line kits consist of all brake lines under the hood. This includes the master cylinder to the distribution, combination or metering valve. The left and right front lines that run to the front flex hoses are also included. Call for individual component pricing. These line kits are for vehicles with factory brake systems.

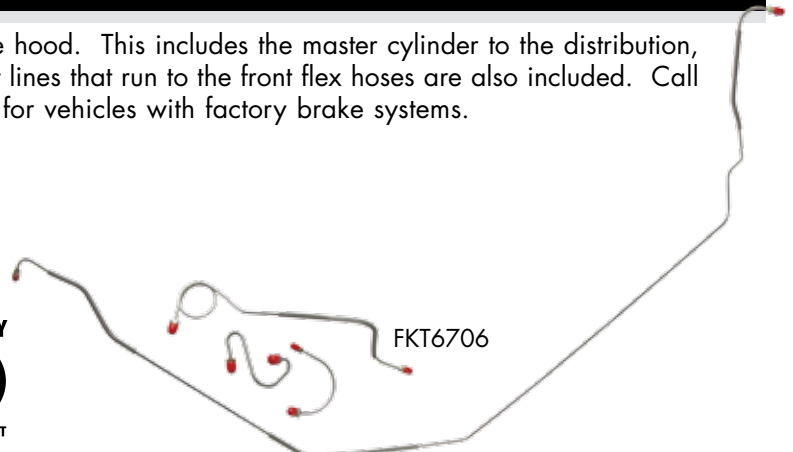
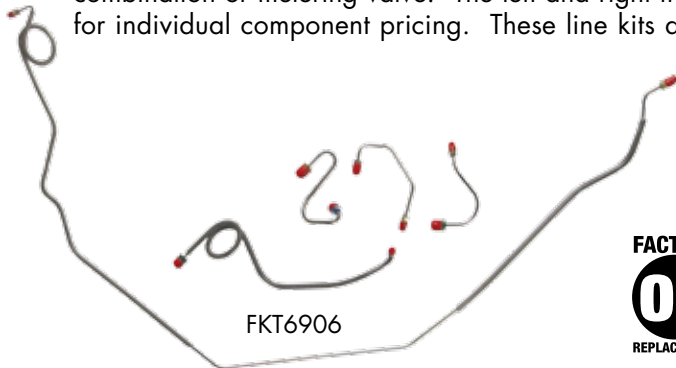

ADD "S" TO PART NUMBER FOR STAINLESS STEEL

- FKT6706 ...67-68... Power Drum
- FKT6709 ...67-68... Manual Drum
- FKT6806 ...67-68... Manual Disc
- FKT6808 ...67-68... Power Disc
- FKT6902 69 Manual Drum
- FKT6904 69 Power Drum
- FKT6906 69 Power Disc
- FKT7005 70 Power Disc, No Armor
- FKT7006 70 Power Disc, Front Master Cylinder Line with Armor

- FKT7103 71 Manual Disc
- FKT7102 ...71-78... Power Disc
- FKT7901 79 Power Disc
- FKT8002 ...80-81... Power Disc
- FKT8201 ...82-83... V-8
- FKT8206 ...82-83... 4 & 6 Cylinder
- FKT8401 ...84-85... V-8
- FKT8406 ...84-85... 4 & 6 Cylinder
- FKT8601 ...86-89... V-8, 1st. Design Valve
- FKT8606 ...86-89... 6 Cylinder, 1st. Design Valve
- FKT8901 ...89-92... V-8, 2nd Design Valve
- FKT8904 ...89-92... 6 Cylinder, 2nd. Design Valve

BRAKE LINE CLIPS

Brake line clip sets contain all the clips needed to fasten the brake tubes to the frame or body of the car. Individual clips and fasteners are available on pages 284-285.

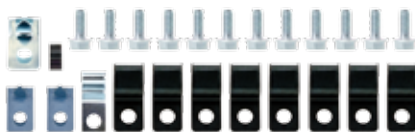

- FCS001 67-68 Complete Set 10 Pcs
- FCS002 69 Complete Set 12 Pcs
- FCS008 70 Complete Set 21 Pcs
- FCS011 71-73 Complete Set 25 Pcs
- FCS012 74 Complete Set 25 Pcs
- FCS013 75-81 Fuel & Brake Clips Includes Bolts 19 Pcs

DISC CALIPER LINES

Front disc caliper lines connect the front flex hoses to the calipers. They were typically used on 4 piston calipers in the late 1960's. Several fitting sizes were available from the factory. Please verify fitting sizes before ordering as rebuilt calipers may not match the originals.



ADD "S" TO PART NUMBER FOR STAINLESS STEEL

- FFC6701 67-68 3/8" x 3/8" Left
- FFC6702 67-68 3/8" x 3/8" Right
- FFC6704 67-68 3/8" x 7/16" Right
- FFC6705 67-68 3/8" x 1/2" Left

FIREBIRD BRAKE LINES & HOSES

REAR AXLE BRAKE LINES

Rear axle brake lines include a pair of lines that run across the rear axle housing. These lines connect the wheel cylinders or calipers to the flex hose in the middle of the rear end. These lines work with original housings that use factory brakes. Modifications such as rear disc brakes or narrowed rear ends will likely require special lines. Call for more information.

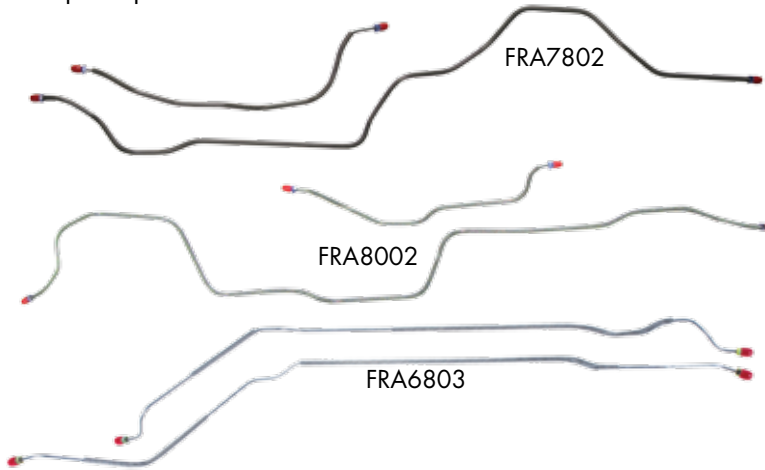

ADD "S" TO PART NUMBER FOR STAINLESS STEEL

- FRA6703 67 All Cars
- FRA6803 68 All Cars
- FRA6903 69 All Cars
- FRA7002 ... 70-74 ... All Cars
- FRA7802 ... 75-81 ... Rear Drum, Std. Suspension
- FRA8002 ... 76-81 ... Rear Drum with F-41 Susp.
- FRA7902 ... 79-81 ... Rear Disc
- FRA82RD 82 4 Wheel Disc
- FRA8201 ... 82-83 ... All Cars
- FRA8401 ... 84-92 ... Rear Drum without HD Rear
- FRA8601 ... 86-92 ... Rear Disc with HD Rear
- FRA8602 ... 86-92 ... Rear Disc without HD Rear

HOSE BRACKETS



These brackets and hardware are used to secure flex hoses to various parts of the vehicle. Front brackets are sold in pairs.

- RSBK6712 ... 67-68 ... 12 Bolt Rear Hose Bracket
- RSBK6702 ... 67-68 ... Body Mount Rear Hose Bracket
- RSBB01 67-68 ... Rear Hose Brass 'T' Block
- RSBK67 67-68 ... Front Hose to 4 Piston Caliper Brackets (pr)
- RSBK69 69 Front Flex Hose Frame Brackets,
Includes 2 Brackets, Clip, & 2 Grommets
- RSBK09 69 12 Bolt Rear Hose Bracket
- FHC01 All Correct Gold Cadmium Plated C Clips
- BB6901 69 Banjo Bolt
- CW6901 69 Copper Washer

FRONT FLEX HOSES

Front flex hoses provide a flexible connection from the body or frame to the front calipers or wheel cylinders as they move during suspension travel. Choose between O.E. rubber or braided stainless steel. All of our hoses are D.O.T. approved. Hoses are priced individually.



ADD "S" TO PART NUMBER FOR STAINLESS STEEL

- FH32 67 Front Drum
- FH201 67-68 Front Disc
- FH02 68-69 Front Drum
- FH03 69 Front Disc
- FHB69 69 Clip, FH03 To Upper Contrl. Arm 2 Pcs
- FH202 70-71 Front Disc
- FH07 72-73 Front Disc
- FH31 74-76 Front Disc
- FH08 77-78 Front Disc
- FH09 79-81 Front Disc
- FH175 ... 82-83 ... Left Front
- FH176 ... 82-83 ... Right Front
- FH158 ... 84-92 ... Left Front without Perf. Package
- FH160 ... 84-92 ... Right Front without Perf. Package
- FH159 ... 88-92 ... Left Front with Perf. Package
- FH161 ... 88-92 ... Right Front with Perf. Package

REAR FLEX HOSES

Rear flex hoses carry brake fluid between the body of the car and the rear. Hoses are available in O.E. rubber and braided stainless steel. 'T' blocks are attached whenever factory correct. All of our hoses are D.O.T. approved. Prices are per hose.



ADD "S" TO PART NUMBER FOR STAINLESS STEEL

- FH06 67-69 All Cars
- FH10 70-71 All Cars
- FH11 72-73 All Cars
- FH12 74-75 All Cars
- FH13 76-81 All Cars
- FH173 82-83 Rear - All, Except 83 Rear Disc, SAE
- FH174 83 Rear Disc, Passenger Side, SAE
- FH156 84-88 Rear Drum Ex. Perf. Package, Metric
- FH157 84-88 Rear Disc. Ex. Perf. Package, Metric
- FH155 88 Left Rear Disc w/ Perf. Package
- FH177 88 Right Rear Disc w/ Perf. Package
- FH155 89-92 Left Rear Disc
- FH177 89-92 Right Rear Disc

AIR CLEANER TUBES

- FAC6801 68-74 without Ram Air, RH Valve Cover
- FAC6901 69-70 Ram Air, RH Valve Cover
- FAC7001 71-72 Ram Air, RH Valve Cover

E-BRAKE CABLES

Parking brake cable sets contain all the individual cables and hardware needed to restore the system. Front, rear, and intermediate cables are also sold individually. Sold in O.E. mild steel and stainless steel. While supplies last.

SEE PAGE 286 FOR PICTURES OF E-BRAKE HARDWARE



• E-Brake Cable Kits

RSBCF0167 Full Cable Set with All Hardware
 RSBCF02 .. 68-69 ... Full Cable Set with All Hardware
 RSBCF03 .. 70-74 ... Full Cable Set with All Hardware
 RSBCF04 .. 75-81 ... Full Cable Set with All Hardware

• Front Brake Cables

EBC7002.. 67-69 ... All Cars
 EBC7004.. 70-74 ... All Cars
 EBC7020.. 75-81 ... All Cars

• Intermediate Brake Cables

EBC8002.....67 All Cars
 EBC8003.. 68-69 ... All Cars

• Rear Brake Cables

EBC9002.....67 All Cars
 EBC9003.. 68-69 ... All Cars
 EBC9006.. 70-74 ... All Cars
 EBC9020.. 75-81 ... Short Jacket, Used with EBC9021
 EBC9021.. 75-81 ... Long Jacket, Used with EBC9020

• E-Brake Hardware

EBH3001....67-74 Olive Green Center Pull
 EBH3002....67-81 Center to Rear Silver Connector
 RSCLP23.....67-81 Parking Brake Clip - Black
 EBH2003....67-69 12" Silver Hook
 EBH1001....67-81 ... Jam Nut
 EBH2004....70-74 J Hook
 EBH1002....70-74 Spring

WHEEL CYLINDERS

Wheel cylinders are priced individually. Hardware is not included.



WC01.....67-69..... Left Front
 WC02.....67-69..... Right Front
 WC03.....67-75..... Rear Left or Right
 WC04.....76-81 Rear Left or Right
 WC56.....82-86..... Rear with US Thread
 WC57.....84-92..... Rear with Metric 10x1.0 Thread

BRAKE SHOES

Shoes are sold in sets of four. Upgrade to the Silencer Precision series for quiet, low dust braking and longer shoe life.

SILENCER PRECISION



BS01 67-69 9" Drum Shoes, 2 pr, Standard Organic
 BS245..... 67-81 9" Drum Shoes, 2 pr, Silencer Precision

SPINDLES

Our spindles are forged steel with precision CNC machining. Two hard to find caliper mounting bolts are included with each pair of spindles. 2" drop installations require caliper bracket and backing plate modifications. All listings are for disc brake systems. Call for drum brake applications.



DBSP0167-69... Disc Brake Spindles with Large Bolts (pr)
 DBSP0467-69... 2" Drop Disc Brake Spindles with Bolts (pr)
 DBSP7078 ...70-78... 2" Drop Disc Brake Spindles (pr)
 DBSP7981 ...79-81... 2" Drop Disc Brake Spindles (pr)

DRUM BRAKES

Brake drums are sold individually.



BD11 67-69 Front Drum, Non-Finned,
 BD12 67-72 Front Drum, Finned
 BD01 67-74 Rear Drum, Finned

FIREBIRD E-BRAKE CABLE & REAR BRAKES

CALIPERS

New calipers are supplied loaded with pads*, banjo bolts and copper washers. No core charge applies. Mounting pins are provided when applicable. Black and Red powder coating options provide a smooth, finished look that is unaffected by leaking brake fluid. *Rebuild and new 4 piston calipers do not include pads or hardware. Core charges apply as noted.

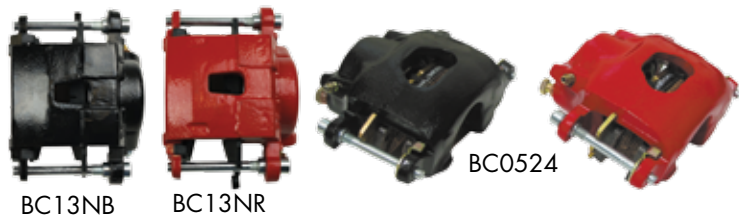

- BC1067-68.... LH, 2-1/16 Caliper, 4 Piston, with Exchange
- BC10C67-68.... Core Charge
- BC1167-68.... RH, 2-1/16 Caliper, 4 Piston, with Exchange
- BC11C67-68.... Core Charge
- BC03LN 69 Left, New with Pads
- BC03RN 69 Right, New with Pads
- BC4344 69 Red or Black Powdercoat (pr)
- BC042470-77.... Red or Black Powdercoat (pr)
- BC052478-81.... Red or Black Powdercoat (pr)
- BC12N.....82-87.... Left Front, New with Pads
- BC13N.....82-87.... Right Front, New with Pads
- BC121382-87.... Red, Black, or Powdercoat (pr)
- BC12N.....88-92.... Left Front, New with Pads, Excl. HP Cars
- BC13N.....88-92.... Right Front, New with Pads, Excl. HP Cars
- BC121388-92.... Red or Black Powdercoat, Except HP Cars

CALIPER BRACKETS

Yellow zinc plating provides corrosion protection on these reproduction brackets.



- CMB0667-68... 4 Piston Caliper Brackets (pr)
- CMB01 69 Single Piston Caliper Brackets (pr)

BACKING PLATES

Often called dust shields, these plates provide some level of protection from road debris.



- DBBP0367-68... 4 Piston Backing Plates (pr)
- DBBP01 69 Single Piston Backing Plates (pr)

DISC BRAKE PADS

Brake pads are sold in sets of four. Our base line is a midgrade standard offering. Step up to the Silencer Professional line for less dust, quieter braking, and longer pad life.



- DP01 67-68 4 Piston Caliper Pads (2 pr)
- DP02 69-81 Single Piston Caliper Pads (2 pr)
- DP23 82-87 Single Piston Caliper Pads (2 pr)
- DP23 67-92 Rear Pads (2 pr), with RSD Rear Disc

ROTORS

Brake rotors are shipped with bearing races installed. A Drilled-Slotted-Zinc Plated option is available on select rotors.



- BR01C..... 67-68 ... Front Rotor, 4 Piston, 1 Pc Design
- BR69C..... 67-68 ... Front Rotor, 4 Piston, 2 Pc Design
- BR02C.....69 Front Rotor, 1 Pc Design
- BR03C..... 70-78 ... Front Rotor
- BR04C..... 79-81 ... Front Rotor
- BR08C..... 82-92 ... Front Rotor

MINI KITS

Mini kits include a pair of spindles, caliper brackets, and backing plates. These kits are a great value to freshen up the front end on a restoration project, or to build out a drum to disc brake conversion.

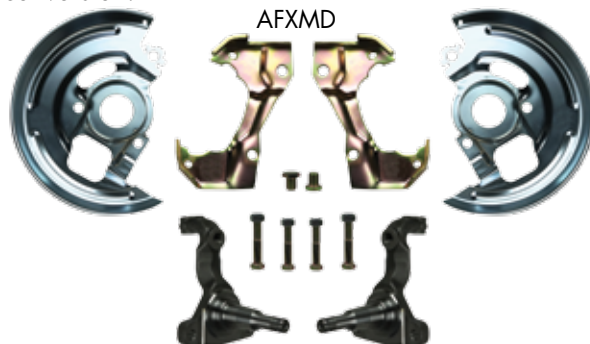

- AFXMD67-69... Standard Height, Single Piston Calipers
- AFXMD4.....67-69... 2" Drop, Single Piston Calipers
- AFXMD3.....67-69... Standard Height, 4 Piston Piston Calipers

SLIMLINE BOOSTER MASTER COMBOS

J81315672

The slimline combos offer clean lines and plenty of power in a small package. The 8" dual is our favorite. Mounting brackets included.



J81315672 TOP VIEW

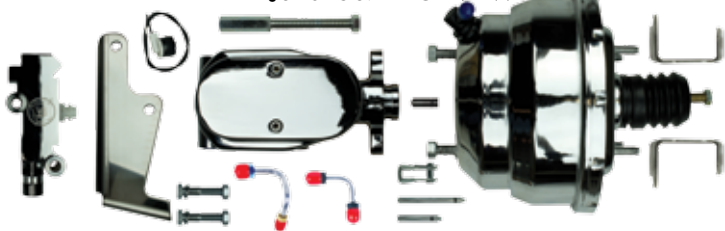

- G8131097167-69.... 8" Dual, Standard Gold, Disc/Drum
- J81315171.....67-69.... 8" Dual, Chrome, Disc/Drum
- G81310572.....67-69.... 8" Dual, Standard Gold, Disc/Disc
- J81315672.....67-69.... 8" Dual, Chrome, Disc/Disc
- G9102097167-69.... 9" Single, Standard Gold, Disc/Drum
- G91020572.....67-69.... 9" Single, Standard Gold, Disc/Disc

SLIMLINE BOOSTERS

Slimline boosters pack a lot of punch in a small, sleek package. Dual diaphragm versions provide 25% - 35% more assist than their single diaphragm equivalent. The 8" dual is our most popular for clearing big blocks while providing plenty of assist for two or four wheel disc brake systems. Mounting brackets included.



RPB7137



RPB7137C



RPB8131



RPB8131C

- RPB7137 67-69 7" Dual, Standard Gold
- RPB7137C 67-69 7" Dual, Chrome Plated
- RPB7137S 67-69 7" Dual, Polished Stainless
- RPB8131 67-69 8" Dual, Standard Gold
- RPB8131C 67-69 8" Dual, Chrome Plated
- RPB8131S 67-69 8" Dual, Polished Stainless
- RPB9102 67-69 9" Single, Standard Gold

DELCO BOOSTER MASTER COMBOS

Factory style for 67-81 GM. Can be tight on big block cars. Available with or without Delco stamping. Mounting brackets included.

G91210971



G91210971 TOP VIEW

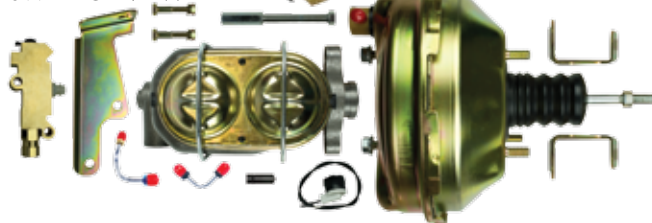

- G91210971 67-69 9" Single, Standard Gold, Disc/Drum
- J91215171..... 67-69 9" Single, Chrome, Disc/Drum
- G91210572 67-69 9" Single, Standard Gold, Disc/Disc
- J91215672..... 67-69 9" Single, Chrome, Disc/Disc
- G10030971 67-69 11" Single, Standard Gold, Disc/Drum
- J10035171..... 67-69 11" Single, Chrome, Disc/Drum
- G10030572 67-69 11" Single, Standard Gold, Disc/Disc
- J10035672..... 67-69 11" Single, Chrome, Disc/Disc
- G10011168 69..... 11" Single, Factory Correct Disc/Drum
- FDC001 69..... 11" Single, Factory Correct Disc/Drum
- G10060171 71-81 11" Single, Standard Gold, Disc/Drum
- G10070171 71-81 11" Single, Standard Gold w/ stamp
- G10060572 71-81 11" Single, Standard Gold, Disc/Disc

DELCO BOOSTERS

Reproductions based on original factory units. GM licensed & feature a Delco Moraine stamping. This logo is available right side up and upside down. Unstamped boosters are of identical quality, but less expensive without the licensing fees. Includes mounting brackets.



RPB1001



RPB1003



RPB1003C

- RPB902267-69... 9" Standard Gold
- RPB9121C...67-69... 9" Chrome Plated
- RPB901667-69... 9" Standard Gold, with Delco Stamping
- RPB100367-69... 11" Standard Gold
- RPB1003C...67-69... 11" Chrome Plated
- RPB100167-69... 11" Std.Gold, with Right Side Up Delco
- RPB100867-69... 11" Std.Gold, with Upside Down Delco
- RPB100670-81... 11" Standard Gold
- RPB100770-81... 11" Standard Gold, with Delco Stamping

FIREBIRD MASTER CYLINDERS

MASTER CYLINDERS

All master cylinders are completely new units with no core charge. A deep cylinder pocket with a removable plug provides compatibility with manual brakes as well as power-assisted applications.



DBMC01

DBMC09

DBMC11



DBMC51C



DBMC51C

- DBMC0567-69... Power Disc, 1" Bore, Deep Pocket
- DBMC0967-69... Power Disc, 1-1/8" Bore, Deep Pocket
- DBMC1167-69... Power Disc, with Bleeders, 1-1/8" Bore, Deep, Exact Repo for '69, Delco Licensed
- DBMC1667-69... Power Disc, with Bleeders, 1-1/8" Bore, Deep, Same as DBMC11 without Casting Marks
- DBMC0170-81... Power Disc, 1-1/8" Bore, Shallow Pocket
- DBMC1970-81... 1-1/8" Bore, with Bleeders
- DBMC09C...67-81... 1-1/8" Bore, Chrome
- DBMC05C...67-81... 1" Bore, 4 Wheel Disc, Chrome
- DBMC51C...67-81... 1-1/8" Bore, Slimline Flat Top, Chrome
- DBMC56C...67-81... 1" Bore, Slimline Flat Top, Chrome

VALVES & BLOCKS

We offer a full line of metering blocks, proportioning valves, distribution blocks and combination valves for factory drum and disc brake applications.



PV05



PV71



PV68



PV70

- PV68 67-69..... Hold-Off Valve with Bracket
- PV05 67-69..... Distribution Block with Bracket
- PV01 All Adjustable Valve
- PV7070 Hold-Off Valve with Bracket
- PV71 71-81 Disc/Drum Combination Valve, Brass
- PV71C..... 71-81 Disc/Drum Combination Valve, Chrome
- PV72 71-81 Disc/Disc Combination Valve, Brass
- PV72C..... 71-81 Disc/Disc Combination Valve, Chrome
- PVB73 71-81 Combination Valve Bracket

POWER STEERING LINES

Lines can be either pressure or return feeds in a power steering system.

ADD "S" TO PART NUMBER FOR STAINLESS STEEL

- FPS690169 ...Power Steering Line
- FPS6901B...69 ...Power Steering Line, Mounting Clips 2pc

TRANSMISSION COOLER LINES

Transmission cooler lines are sold as pairs. Be sure to verify the type of transmission in your project before ordering. These lines are intended to work only with factory motor, transmission, and radiator combinations.

ADD "S" TO PART NUMBER FOR STAINLESS STEEL

- FTC6702 ...67-69.... Powerglide
- FTC6706 ...67-69.... T-350 & 400
- FTC7003 ...70-74.... T-350 & 400, Front 5/8" Nut
- FTC7004 ...70-74.... T-350 & 400, Front 1/2" Nut
- FTC7704 77 Trans Am 400ci w/T-350 only
- FTC7801 ...76-81.... Non Turbo TH-350
- FTC7701 77 301 with T-350
- FTC7901 79 Trans Am, 403 with T-350
- FTC79AX 79 Auxilliary Cooler Lines
- FTC8001 ...80-81.... Trans Am 301 Non Turbo with TH200
- FTC8101 ...80-81.... Floating Turbo
- FTC8701 ...87-92.... 700R4

TRANSMISSION VACUUM LINES

Lines connect automatic transmissions to intake vacuum.

ADD "S" TO PART NUMBER FOR STAINLESS STEEL

- FTV7101 67-72T-350
- FTV6906 696 Cylinder, Overhead Cam
- FTV6907 69T-300 with 350 2 BBL
- FTV7002 70-72T-400
- ATV730173455
- FTV760076T-350
- FTV790179T-350, 6.6L

DISTRIBUTOR VACUUM

Distributor vacuum lines supply intake vacuum to the distributor for timing control.

ADD "S" TO PART NUMBER FOR STAINLESS STEEL

- FDV670867 6 Cylinder, Overhead Cam 4 BBL
- FDV671067 400
- FDV690669 6 Cylinder, Overhead Cam
- FDV691069 400, 4 BBL

THERMAL CHOKE LINES

Thermal choke lines carry heat from the exhaust system to the choke coil on the carburetor. Some applications route thru the intake manifold on their way to the carburetor.

ADD "S" TO PART NUMBER FOR STAINLESS STEEL

- FCH7301 73-74Firebird Choke Tube Set 2 Pcs.

MAIN FUEL LINES

Main lines carry fuel from the tank in the rear of the car to the fuel pump or rail in the front. They are available in 3/8" and 5/16" tubing based on factory specifications. Multiple piece sets are noted. Call for 1/2" lines.

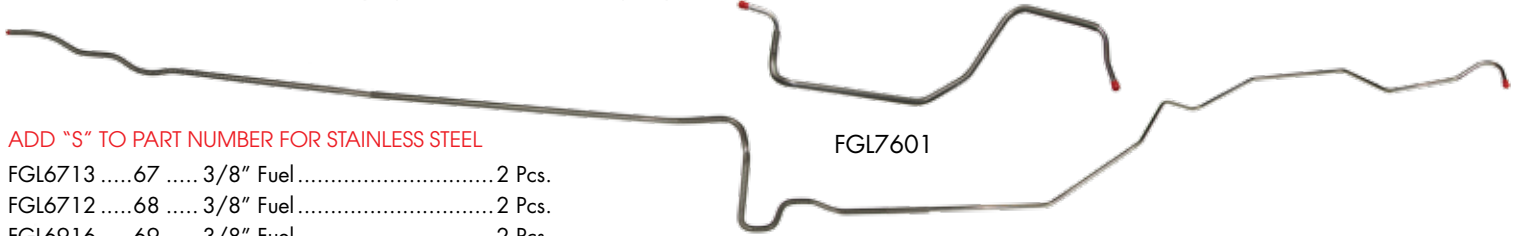

ADD "S" TO PART NUMBER FOR STAINLESS STEEL

FGL671367 3/8" Fuel 2 Pcs.
FGL671268 3/8" Fuel 2 Pcs.
FGL691669 3/8" Fuel 2 Pcs.
FGL700370 3/8" Trans-Am 2 Pcs.
FGL7103	.. 71-73	... 3/8" Passenger's Side, Ends at Front Sub-Frame 2 Pcs.
FGL740374 3/8" Passenger's Side 2 Pcs.
FGL7401	.. 74-75	... 3/8" Trans-Am 2 Pcs.
FGL740374 3/8" Passenger Side 2 Pcs.
FGL750175 3/8" Right Side 2 Pcs.
FGL760176 3/8" Formula 350 2 Pcs.
FGL7601	.. 76-81	... 3/8" Pontiac 400, Left Hand	... 2 Pcs.
FGL780177 3/8" Main, 305ci, 2 BBL 2 Pcs.

FGL7903	.. 77-79	... 3/8" Olds 403, Left Side 2 Pcs.
FGL810581 3/8" T/A, 305 2 Pcs.
FGL8203	.. 82-84	... 3/8" Main Fuel Line, RH 2 Pcs.
FGL8503	.. 85-91	... 3/8" Main Fuel Line, Carb, LH 2 Pcs.
FGL8506	.. 85-91	... 3/8" Main Line From Fuel Filter Forward To Rubber Hose 2 Pcs.
FGL8507	.. 85-91	... 3/8" Main Line From Fuel Filter Back to Tank 2 Pcs.
FGL8508	.. 85-91	... 3/8" Main Line From Rubber Hose To Fuel Rail 2 Pcs.

RETURN FUEL LINES

Return lines carry excess fuel from fuel pump or fuel filter back to the tank. Not all vehicles were equipped with a return line. They are typically made of 1/4" diameter tubing. Multiple piece sets are noted.

ADD "S" TO PART NUMBER FOR STAINLESS STEEL

FGL691770 1/4" Return Line 2 Pcs.
FGL700470 1/4" Trans-Am, Driver's Side 2 Pcs.
FGL7104	.. 71-73	... 1/4" Passenger's Side, Ends at Front Sub-Frame 2 Pcs.
FGL740474 1/4" Passenger Side 2 Pcs.
FGL7402	.. 74-75	... 1/4" Trans-Am 2 Pcs.

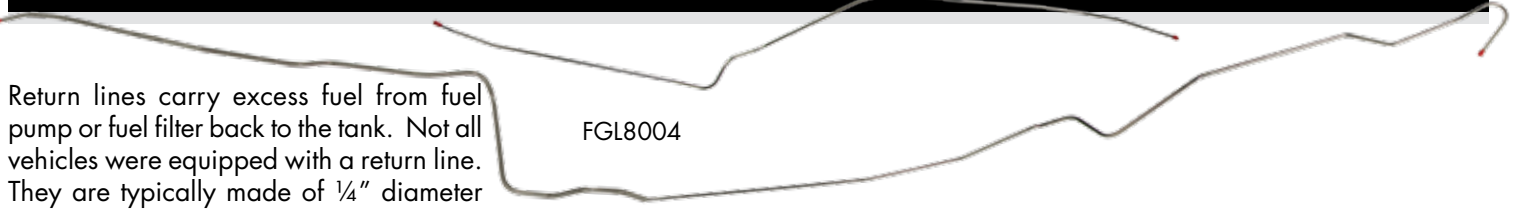

FGL750275 1/4" Right Side 2 Pcs.
FGL7602	.. 76-78	... 1/4" Pontiac 400, RH 2 Pcs.
FGL800479 1/4" Olds 403, RH 2 Pcs.
FGL8003	.. 79-81	... 1/4" Pontiac 400, Right Side 2 Pcs.
FGL810681 1/4" T/A, 305 2 Pcs.
FGL8204	.. 82-84	... 1/4" Return Line, LH 2 Pcs.
FGL8205	.. 82-84	... 5/16" Return Line, RH 2 Pcs.
FGL8505	.. 85-91	... 5/16" Return Line, Carb, LH 2 Pcs.

VAPOR RETURN LINES

Emission control systems use these 5/16" lines to handle fuel vapors. Some vehicles use a single front to rear line. Others utilize a charcoal canister and require 3 or 4 additional small lines. Multiple piece sets are noted.

ADD "S" TO PART NUMBER FOR STAINLESS STEEL

FGL6714	... 67-68	... 1/4" Vapor Line 2 Pcs.
FGL6918 69 1/4" Vapor Line 2 Pcs.
FEM7001	.. 70-73	... Driver's Side 5 Pcs.
FEM7401 74 Driver's Side 2 Pcs.
FEM7402 74 Passenger's Side 2 Pcs.
FEM05 75-77	... Driver's Side 2 Pcs.
FEM06 75-78	... Passenger's Side 2 Pcs.
FEM10 77 305, 2 BBL 2 Pcs.

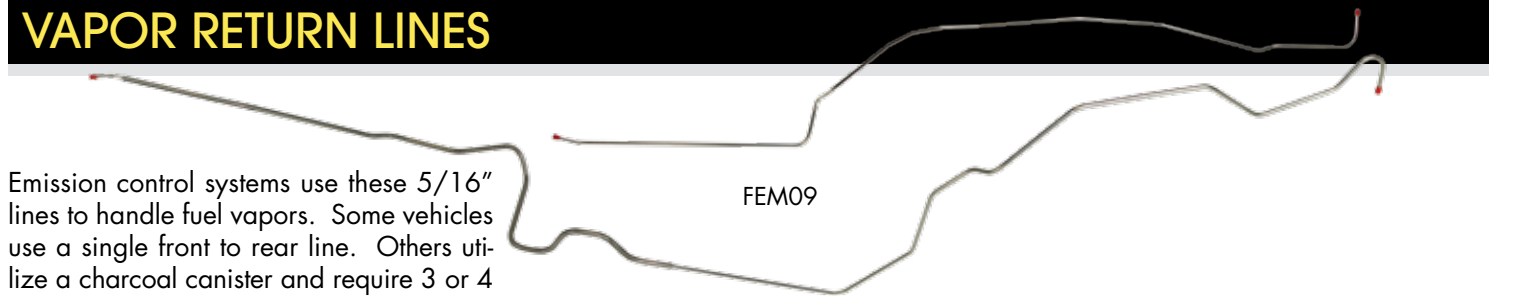

FEM18 78 5/16" Driver Side Vapor Line with Tank Crossover 2 Pcs.
FEM08 78-81	... Olds 403 Driver's Side 2 Pcs.
FGL7908 79 5/16" Vent Line 2 Pcs.
FEM09 79-81	... Pont. 400 Passenger's Side 2 Pcs.
FEM81 81 Vapor Line 2 Pcs.
FGL8206	... 82-84	... 5/16" Vapor Line, LH 2 Pcs.
FGL8510	... 85-91	... 5/16" Vapor Line, LH 2 Pcs.
FGL8511	... 85-91	... 1/4" Vapor Line, Carb, LH 2 Pcs.
FGL8512	... 85-91	... 1/4" Vapor Line, RH 2 Pcs.

FIREBIRD FUEL COMPONENTS

FUEL TANKS

Fuel tanks are constructed of Ni-Terne steel. Hardware is not included.



FFT7103



FFT6901



FFT7401



- FFT6701 ... 67-68 ... Firebird, No Filler Neck
- FFT6901 69 Firebird
- FFT7001 ... 70-73 ... Firebird without ECS
- FFT7103 ... 71-73 ... Firebird with ECS, 3 Vents on Front
- FFT7401 ... 74-78 ... Firebird
- FFT7801 ... 79-81 ... Firebird
- FFT8202 ... 82-92 ... Firebird, EFI, 15 Gallon

FUEL LINE CLIPS

Fuel line clips hold tubing to the frame or body of the car. Fasteners are included as noted. See page 284-285 for individual clips.



FCS005

- FCS003 67-68 with 3/8" Fuel Line, No Return
- FCS004 69 with 3/8" Fuel Line, No Return
- FCS005 69 with 3/8" Fuel & 1/4" Return

FUEL HOSE KITS

These small rubber hoses and clips are used to connect fuel lines to the fuel pump and sending unit.



FHK3800

Cost

- FHK3800 ALL 3/8" x 6", 3/8" x 13", + 4 Green Clamps
- FHK1438 ALL 3/8" x 6", 3/8" x 13", 1/4" x 18"
+ 4 Green Clamps and 4 Red Clamps

FUEL PUMP TO CARBURETOR

Fuel pump to carburetor lines connect the fuel pump to the carburetor. Brass blocks and fittings are included as noted. These lines are intended to work only with factory pump, motor, intake and carburetor combinations.

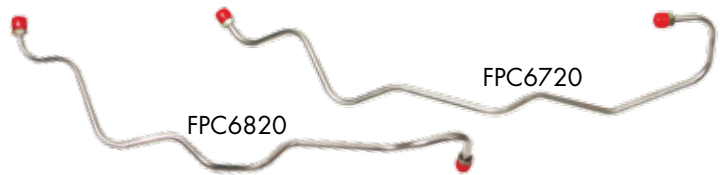

ADD "S" TO PART NUMBER FOR STAINLESS STEEL

- FPC6708 67 6 Cylinder, Overhead Cam 4 BBL
- FPC6711 67 400, Carter 4 BBL
- FPC6720 67 4 BBL, without Vent Line
- FPC6721 67 4 BBL, H-O Kit (3 Lines with Vent)
- FPC6722 67 Fuel Filter Bracket
- FPC6820 68 4 BBL
- FPC6920 69 4 BBL
- FPC6921 69 Ram Air 4
- FPC7020 70 400, 4 BBL
- FPC7021 70 Ram Air
- FPC7023 70 455, 2 BBL
- FPC7101 71 350, 2 BBL
- FPC7120 71 400, 4 BBL
- FPC7220 72 400, 4 BBL
- FPC7401 74 400, 4 BBL
- FPC7505 75 400, 4 BBL
- FPC7520 ... 75-77 ... 400, 2 BBL
- FPC7602 76 455 Pontiac T/A
- FPC7903 ... 77-79 ... 403
- FPC7904 ... 77-79 ... 400, 4 BBL, L72 without Foam
- FPC7905 80 301 Turbo
- FPC8002 80 301 Non Turbo
- FPC8100 81 305
- FPC8201 ... 82-92 ... 6 Cylinder

FUEL SENDING UNITS

Sending units include floats, gaskets and snap rings where applicable. Our fuel senders are made of stainless steel and operate on the same ohm range as factory gauges.

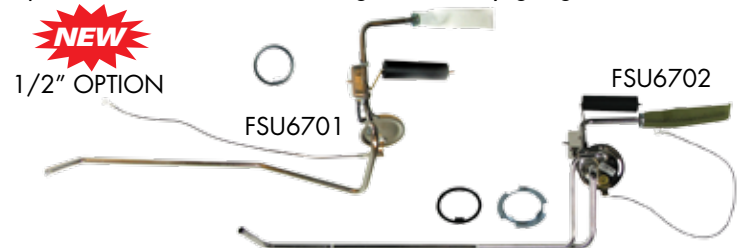

1/2" OPTION

FSU6701

FSU6702

- FSU6701 67-69 3/8" Main
- FSU6721 67-69 1/2" Main
- FSU6702 67-69 3/8" Main & 1/4" Return
- FSU6722 67-69 1/2" Main & 1/4" Return
- FSU7021 70-73 1/2" Main
- FSU7601 76-81 3/8" Main
- FSU7602 76-81 3/8" Main & 1/4" Return

SUSPENSION COMPONENTS

UPPER & LOWER BALL JOINTS

COMING IN 2017

XK510367-69... Lower
 XK510867-69... Upper
 XK614570-02... Lower
 XK520870-81... Upper



XK5103 XK5108

SWAY BAR LINK KITS

XK621767-69... All
 XK525270-02... All



XK6217

UPPER & LOWER CONTROL ARM BUSHING KITS

XK607667-72... Lower
 XK519667-69... Upper
 XK610870-73... Upper
 XK610973-81... Lower
 XK614474-79... Upper



XK6076 XK5196

IDLER ARMS

COMING IN 2017

FIA6701 67 Idler Arm
 FIA680168-69... Idler Arm
 FIA700170-81... Idler Arm



FIA6701

INNER & OUTER TIE RODS & SLEEVES



XE5350S

XE5681N

XES681N 67-68Inner
 XES381RL68Outer
 XES350S 67-68Adjusting Sleeve
 XES2004S 69-81Adjusting Sleeve
 XES404RL 70-75Outer
 XES2001L 75-81Inner, Driver Side
 XES2002L 75-81Inner, Pass Side
 XES427R 75-80Outer, with V6
 XES2032S 82-92Adjusting Sleeve

STEERING ARMS

COMING IN 2017



DBSA0267-69... Steering Arms, 1/2" Bolt Holes (pr)

SWAY BAR BUSHINGS

COMING IN 2017

XK5227... 67-69... All
 XK5253... 70-75... 1" or Larger Bar
 XK5241... 70-75... 15/16" or Smaller
 XK5241... 76-81... 15/16" or Smaller, with Tabs on Mounting Clamp
 XK6161... 76-81... 1 to 1 1/8" Bar, with Tabs on Mounting Clamp
 XK5288... 76-91... 1-1/16" Bar, without Tabs on Mounting Clamp
 XK6451... 76-91... 1" Bar without Tabs on Mounting Clamp
 XK6453... 76-91... 1-1/8" Bar without Tabs on Mounting Clamp
 XK5248... 76-91... 1-3/16" without Tabs on Mounting Clamp
 XK6455... 76-91... 1-1/4" Bar without Tabs on Mounting Clamp
 XK6457... 76-91... 1-5/16" Bar without Tabs on Mounting Clamp
 XK6459... 76-91... 1-7/16" Bar without Tabs on Mounting Clamp

SUSPENSION KITS

Standard rubber kits meet O.E. specifications. Polyurethane kits provide better handling and a firmer ride. Poly kits include upgraded control arm bushings, sway bar bushings, and sway bar links. Pre-packaged kits offer huge savings over individual suspension parts. Most kits include the following:

- Lower Ball Joints (2)
- Upper Ball Joints (2)
- Lower Ctrl. Arm Bushings (4)
- Upper Ctrl. Arm Bushings (4)
- Inner Tie Rods (2)
- Sway Bar Link Kits (2)
- Tie Rod Adj. Sleeves (2)
- Sway Bar Bushings (2)
- Outer Tie Rods (2)



FSK6701

COMING IN 2017

FSK670167-69.... Front Rebuild Kit, 22-Pieces
 FSK6701U...67-69.... Front Rebuild Kit, 22-Pieces (Poly)
 FSK700170-72.... Front Rebuild Kit, 24-Pieces
 FSK730173 Front Rebuild Kit, 24-Pieces
 FSK740174 Front Rebuild Kit, 24-Pieces
 FSK750175 Front Rebuild Kit, 24-Pieces
 FSK760176-79.... Front Rebuild Kit, 26-Pieces with 15/16", 1-1/8", & 1-3/16" Sway Bar with Tabs on Mounting Clamps
 FSK670276-79.... Front Rebuild Kit, 24-Pieces with 1" & 1-1/16" Sway Bar without Tabs on Mounting Clamps
 FSK760376-79.... Front Rebuild Kit, 24-Pieces with 1-1/8" & 1-3/16" Sway Bar without Tabs on Mounting Clamps
 FSK760476-79.... Front Rebuild Kit, 26-Pieces with 1-1/4", 1-5/16", & 1-7/16" Sway Bar without Tabs on Mounting Clamps

FIREBIRD FRONT BRAKE CONVERSIONS

**STREET
SERIES**

FRONT DISC BRAKE CONVERSION KITS

U.S.A. Made
TIMKEN Bearings

FRONT CONVERSIONS INCLUDE:

- 11" Rotors
- Forged Spindles
- Timken Bearings
- New Calipers
- Caliper Brackets
- Organic Pads
- Backing Plates
- Flex Hoses & Clips
- Valve Bracket & Hardware
- Banjo Bolts & Copper Washers
- Dust Caps
- Castle Nuts & Pins
- Washers
- Grease Seals
- Spindle Gaskets
- Steering Arm Bolts
- Master Cylinder
- Combination Valve
- Pedal Rod Extension
- Brake Switch Pigtail

WORKS WITH FACTORY 14" OR LARGER DISC BRAKE WHEELS

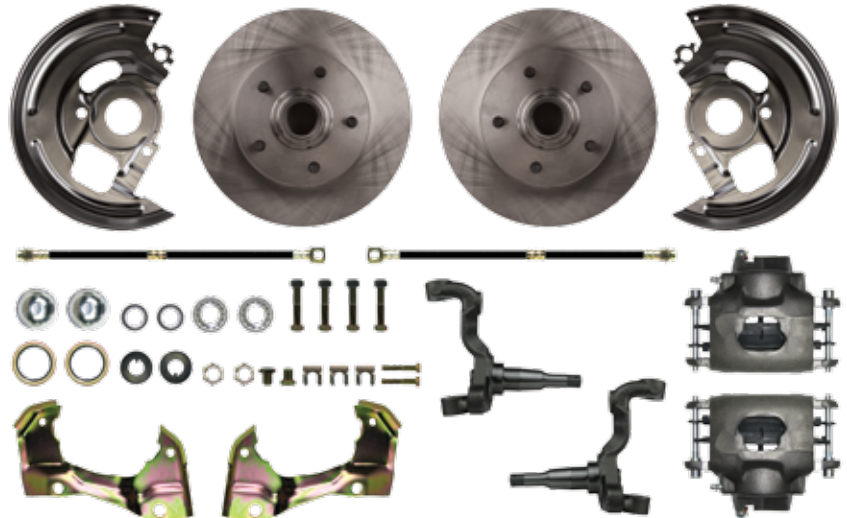

Right Stuff disc conversions are the most complete kits in the industry at the right price. High quality components, professional packaging, and after-sale support by "hands-on" technicians create an unbeatable value. Consider one of our complete brake line packages for a carefree installation.



Packages include At-the-Wheel Disc Conversion Kit & Master Cylinder with Valve (Manual) or Master Cylinder with Booster and Valve (Power).

POWER PACKAGE

MANUAL PACKAGE

11" inch booster, Call for other diameters

UPGRADES

The next page offers upgrades to fully customize your conversion kit.

AT-THE-WHEEL FRONT KITS

STOCK HEIGHT FRONT KITS

- AFXWK01C ...67-69.... At-the-Wheel Disc Conversion Kit
- AFXSD01C.....67-69.... Manual Disc Conversion Package
- AFXDC01C.....67-69.... Power Disc Conversion Package

2" DROP FRONT KITS

- AFXWK02D ...67-69.... 2" Drop At-the-Wheel Disc Conversion Kit
- AFXSD02D.....67-69.... 2" Drop Manual Disc Conversion Package
- AFXDC02D67-69.... 2" Drop Power Disc Conversion Package



FRONT DISC BRAKE CONVERSION UPGRADES

STREET SERIES

SHOW'N GO UPGRADE TRIM KITS

These At-the-Wheel Disc Conversion Kits (stock height or 2" drop) include upgraded drilled slotted rotors with zinc plating, powder coated calipers in red or black, and braided stainless hoses.



STOCK HEIGHT SHOW'N GO

AFXWK01CS ... 67-69.... At-the-Wheel Disc Conversion Kit - Black
AFXWK01CZ ... 67-69.... At-the-Wheel Disc Conversion Kit - Red

2" DROP SHOW'N GO

AFXWK02DS ... 67-69.. 2" Drop At-the-Wheel Disc Conv Kit - Black
AFXWK02DZ ... 67-69.. 2" Drop At-the-Wheel Disc Conv Kit - Red

SHOW STOPPER TRIM PACKAGES

Includes At-the-Wheel Front Disc Conversion Kit (stock height or 2" drop) with natural finish calipers. The Manual Packages get an upgraded chrome plated master cylinder and combination valve with bracket. Power Packages include an upgraded 8" dual chrome booster.

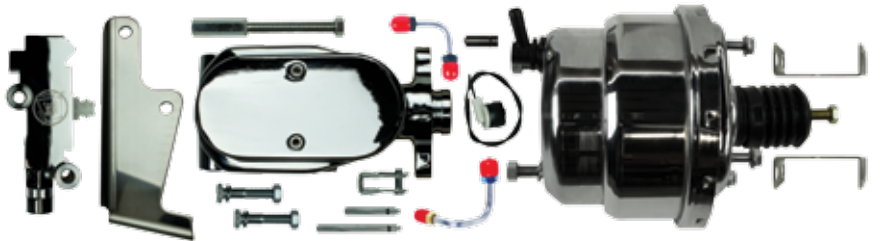

STOCK HEIGHT SHOW STOPPER

AFXSD01CX..... 67-69Manual Disc Conversion Package
AFXDC01CX..... 67-69Power Disc Conversion Package

2" DROP SHOW STOPPER

AFXSD02DX..... 67-69 ... 2" Drop Manual Disc Conversion Package
AFXDC02DX ... 67-69 ... 2" Drop Power Disc Conversion Package

BEST OF SHOW TRIM PACKAGES

Includes At-the-Wheel Front Disc Conversion Kit (stock height or 2" drop) with black or red calipers, drilled & slotted rotors & braided stainless hoses. The Manual Packages get an upgraded chrome plated master cylinder and combination valve with bracket. Power Packages include an upgraded 8" dual chrome booster.



STOCK HEIGHT BEST OF SHOW

AFXSD01CSX.... 67-69 Manual Disc Conversion Package - Black
AFXSD01CZX.... 67-69 Manual Disc Conversion Package - Red
AFXDC01CSX ... 67-69 Power Disc Conversion Package - Black
AFXDC01CZX ... 67-69 Power Disc Conversion Package - Red

2" DROP BEST OF SHOW

AFXSD02DSX 67-69 ... 2" Drop Manual Disc Conv Pkg - Black
AFXSD02DZX 67-69 ... 2" Drop Manual Disc Conv Pkg - Red
AFXDC02DSX.... 67-69 ... 2" Drop Power Disc Conv Pkg - Black
AFXDC02DZX ... 67-69 ... 2" Drop Power Disc Conv Pkg - Red



Disc Brake Conversions require special brake lines that fit your new disc conversion setup. Right Stuff offers "No Brainer" Brake Line Kits that include all components needed from your master cylinder back to your rear wheel cylinder or calipers. They include front brake line kit, front to rear line, rear axle lines & flex hose, & clip set.

See page 154 for your application

FIREBIRD 4-WHEEL BRAKE CONVERSIONS

**STREET
SERIES**

FOUR WHEEL DISC BRAKE CONVERSION KITS

U.S.A. Made
TIMKEN Bearings

FOUR WHEEL CONVERSIONS INCLUDE:

- 11" Rotors
- Forged Spindles
- Timken Bearings
- New Calipers
- Caliper Brackets
- Organic Pads
- Backing Plates
- Flex Hoses & Clips
- Valve Bracket & Hardware
- Banjo Bolts & Copper Washers
- Rear Bracket Spacers
- Weld-On Hose Brackets
- Dust Caps
- Castle Nuts & Pins
- Washers
- Grease Seals
- Spindle Gaskets
- Steering Arm Bolts
- Master Cylinder
- Combination Valve
- Pedal Rod Extension
- Brake Switch Pigtail
- E-Brake Cables

Right Stuff disc conversions are the most complete kits in the industry at the right price. High quality components, professional packaging, and after-sale support by "hands-on" technicians create an unbeatable value. Consider one of our complete brake line packages for a carefree installation. See page 149 to verify axle flange measurements for these kits.

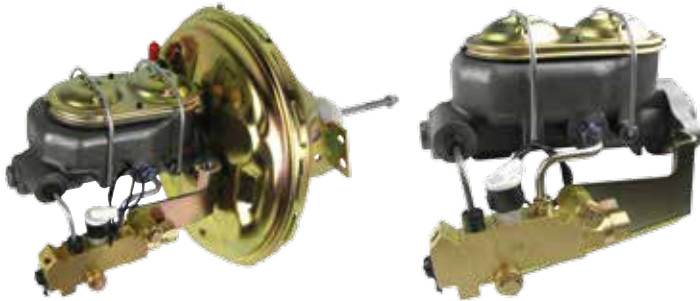

Packages include At-the-Wheel Disc Conversion Kits & Master Cylinder with Valve (Manual) or Master Cylinder with Booster and Valve (Power).

POWER PACKAGE

MANUAL PACKAGE

11"inch booster. Call for other diameters

STOCK HEIGHT 4-WHEEL KITS

- AFXSD41C..... 67 Manual Disc Brake Conv Pkg - Non-Staggered
- AFXDC41C..... 67 Power Disc Brake Conv Pkg - Non-Staggered
- AFXSD45C... 68-69.. Manual Disc Brake Conv Package - Staggered
- AFXDC45C.. 68-69.. Power Disc Brake Conv Package - Staggered

WORKS WITH 15" AND LARGER WHEELS

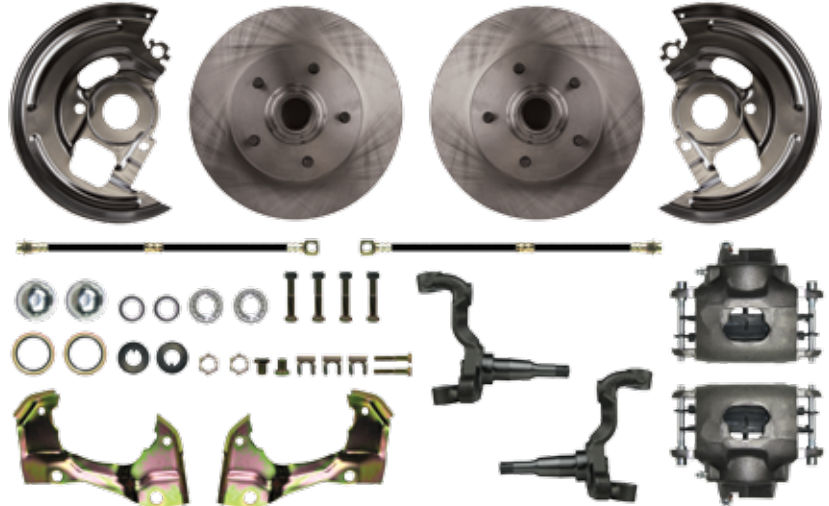

AT-THE-WHEEL FRONT KIT

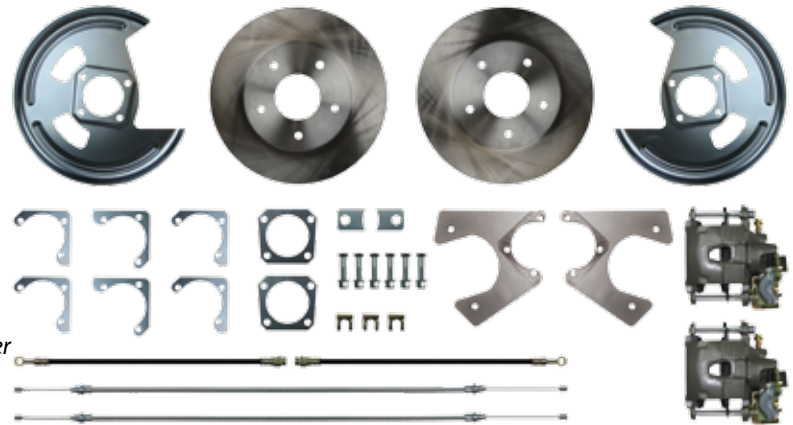

AT-THE-WHEEL REAR KIT

6-3/16" INSIDE ROTOR DIAMETER - 2.78" CENTER HOLE

2" DROP 4-WHEEL KITS

- AFXSD42D.....67 2" Drop Manual Disc Brake Conv Pkg - Non-Stag
- AFXDC42D.....67 2" Drop Power Disc Brake Conv Pkg - Non-Stag
- AFXSD45D... 68-69.. 2" Drop Manual Disc Brake Conv Pkg - Staggered
- AFXDC45D.. 68-69.. 2" Drop Power Disc Brake Conv Pkg - Staggered

UPGRADES

The next page offers upgrades to fully customize your conversion kit.



Disc Brake Conversions require special brake lines that fit your new disc conversion setup. Right Stuff offers "No Brainer" Brake Line Kits that include all components needed from your master cylinder back to your rear wheel cylinder or calipers. They include front brake line kit, front to rear line, rear axle lines & flex hose, & clip set.

See page 154 for your application

4-WHEEL DISC BRAKE CONVERSION UPGRADES **STREET SERIES**

SHOW'N GO UPGRADE TRIM KITS

These At-the-Wheel Disc Conversion Kits (stock height or 2" drop) include upgraded drilled slotted rotors with zinc plating, powder coated calipers in red or black, and braided stainless hoses.



STOCK HEIGHT SHOW'N GO

AFXSD42CS.... 67.....Manual Disc Conv Pkg - Non-Staggered - Black
 AFXSD42CZ.... 67.....Manual Disc Conv Pkg - Non-Staggered - Red
 AFXDC42CS ... 67.....Power Disc Conv Pkg 11" Booster - Non-Stagg - Blk
 AFXDC42CZ ... 67.....Power Disc Conv Pkg 11" Booster - Non-Stag - Red
 AFXSD45CS..68-69 ..Manual Disc Conv Pkg - Staggered - Black
 AFXSD45CZ..68-69 ..Manual Disc Conversion Package - Stagg - Red
 AFXDC45CS .68-69 ..Power Disc Conv Pkg 11" Booster - Staggered - Blk
 AFXDC45CZ .68-69 ..Power Disc Conv Pkg 11" Booster - Staggered - Red

2" DROP SHOW'N GO

AFXSD42DS ...67 .. 2" Drop Manual Disc Conv Pkg - Non-Staggered - Blk
 AFXSD42DZ ...67 .. 2" Drop Manual Disc Conv Pkg - Non-Staggered - Red
 AFXDC42DS...67 .. 2" Drop Pwr Disc Conv Pkg 11" Booster, Non-Stag - Blk
 AFXDC42DZ ..67 .. 2" Drop Pwr Disc Conv Pkg 11" Booster, Non-Stag - Red
 AFXSD45DS ..68-69 .. 2" Drop - Manual Disc Conv Pkg - Staggered - Blk
 AFXSD45DZ ..68-69 .. 2" Drop - Manual Disc Conv Pkg - Staggered - Red
 AFXDC45DS..68-69 .. 2" Drop Pwr Disc Conv Pkg, 11" Booster - Stagg - Blk
 AFXDC45DZ .68-69 .. 2" Drop Pwr Disc Conv Pkg, 11" Booster - Stagg - Red

SHOW STOPPER TRIM PACKAGES

Includes At-the-Wheel Front Disc Conversion Kit (stock height or 2" drop) with natural finish calipers. The Manual Packages get an upgraded chrome plated master cylinder and combination valve with bracket. Power Packages include an upgraded 8" dual chrome booster.

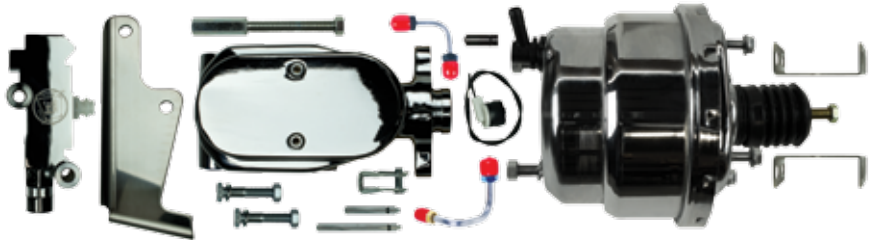

STOCK HEIGHT SHOW STOPPER

AFXSD41CX ... 67.....Manual Disc Brake Conv Pkg - Non-Staggered
 AFXDC41CX... 67.....Power Disc Brake Conv Pkg - Non-Staggered
 AFXSD45CX .68-69 .Manual Disc Brake Conv Package - Staggered
 AFXDC45CX .68-69 .Power Disc Brake Conv Package - Staggered

2" DROP SHOW STOPPER

AFXSD42DX..... 672" Drop Manual Disc Brake Conv Pkg - Non-Stag
 AFXDC42DX..... 672" Drop Power Disc Brake Conv Pkg - Non-Stag
 AFXSD45DX... 68-69 .. 2" Drop Manual Disc Brake Conv Pkg - Staggered
 AFXDC45DX.. 68-69 .. 2" Drop Power Disc Brake Conv Pkg - Staggered

BEST OF SHOW TRIM PACKAGES

Includes At-the-Wheel Front Disc Conversion Kit (stock height or 2" drop) with black or red calipers. The Manual Packages get an upgraded chrome plated master cylinder and combination valve with bracket. Power Packages include an upgraded 8" dual chrome booster.



STOCK HEIGHT BEST OF SHOW

AFXSD41CSX 67..... Manual Disc Brake Conversion Package - Blk
 AFXSD41CZX 67..... Manual Disc Brake Conversion Package - Red
 AFXDC41CSX.... 67..... Power Disc Brake Conversion Package - Black
 AFXDC41CZX.... 67..... Power Disc Brake Conversion Package - Red
 AFXSD45CSX ..68-69 .. Manual Disc Brake Conv Pkg - Staggered - Blk
 AFXSD45CZX ..68-69 .. Manual Disc Brake Conv Pkg - Staggered - Red
 AFXDC45CSX..68-69 .. Power Disc Brake Conv Pkg - Staggered - Blk
 AFXDC45CZX..68-69 .. Power Disc Brake Conv Pkg - Staggered - Red

2" DROP BEST OF SHOW

AFXSD42DSX..... 67.....Manual Disc Brake Conv Package - Black
 AFXSD42DZX..... 67.....Manual Disc Brake Conv Package - Red
 AFXDC42DSX 67.....Power Disc Brake Conv Package - Black
 AFXDC42DZX 67.....Power Disc Brake Conv Package - Red
 AFXSD45DSX...68-69 .. Manual Disc Brake Conv Pkg - Staggered - Black
 AFXSD45DZX...68-69 .. Manual Disc Brake Conv Pkg - Staggered - Red
 AFXDC45DSX ..68-69 .. Power Disc Brake Conv Pkg - Staggered - Black
 AFXDC45DZX ..68-69 .. Power Disc Brake Conv Pkg - Staggered - Red

FIREBIRD REAR BRAKE CONVERSIONS

**STREET
SERIES**

REAR DISC BRAKE CONVERSION KITS

REAR CONVERSIONS INCLUDE:

- 11" Rotors
- Caliper Brackets & Spacers
- Weld-On Hose Brackets
- Flex Hoses
- Backing Plates (Exclusive), not for AFXRD78 or AFXRDM78
- New Loaded Caliper
- E-Brake Cables
- Hardware

Right Stuff disc conversions are the most complete kits in the industry at the right price. High quality components, professional packaging, and after-sale support by "hands-on" technicians create an unbeatable value. Consider one of our complete brake line packages for a care-free installation. See the next page to verify axle flange measurements for these kits.

NOTE:
FITS FACTORY
REAR ENDS
CALL FOR CUSTOM
APPLICATIONS

WORKS WITH 15" AND LARGER WHEELS

6 3/16" INSIDE ROTOR DIAMETER - 2.78" CENTER HOLE

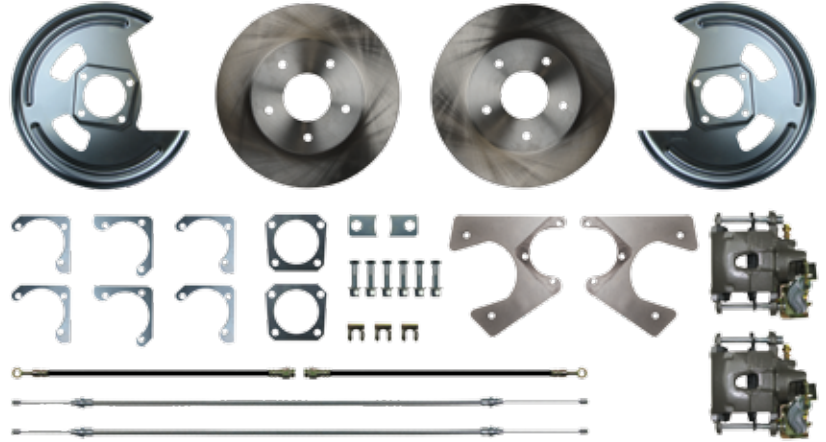

KITS WITH E-BRAKE

- AFXRD01 67 10 & 12 Bolt without Staggered Shocks
- AFXRD05 68-69 ... 10 & 12 Bolt with Staggered Shocks
- AFXRD06 70-74 ... 10 & 12 Bolt with Staggered Shocks
- AFXRD07 75-81 ... 10 & 12 Bolt with Staggered Shocks
- AFXRD82 82-92 ... 10 Bolt without Staggered Shocks

KITS WITHOUT E-BRAKE

- AFXRDM1 67 10 & 12 Bolt without Staggered Shocks
- AFXRDM5 68-81 10 & 12 Bolt with Staggered Shocks
- AFXRDM78 82-92 10 Bolt without Staggered Shocks

WANT MATCHING FRONT UPGRADES?

SEE THE NEXT PAGE FOR OUR REAR+2 CONVERSIONS

ATTENTION Before you order, be sure to measure the axle flange on your vehicle.

REAR DISC BRAKE CONVERSION UPGRADES

**STREET
SERIES**

SHOW'N GO UPGRADE TRIM PACKAGES

These packages add drilled slotted rotors with zinc plating, powder coated calipers in red or black, and braided stainless hoses. Just add an "S" for black calipers or a "Z" for red calipers to the end of your conversion part number.



REAR UPGRADE WITH E-BRAKE

- AFXRD01S 67 10 & 12 Bolt w/o Staggered Shocks - Black
- AFXRD01Z 67 10 & 12 Bolt w/o Staggered Shocks - Red
- AFXRD05S 68-69 ... 10 & 12 Bolt with Staggered Shocks - Black
- AFXRD05Z 68-69 ... 10 & 12 Bolt with Staggered Shocks - Red
- AFXRD06S 70-74 ... 10 & 12 Bolt with Staggered Shocks - Black
- AFXRD06Z 70-74 ... 10 & 12 Bolt with Staggered Shocks - Red
- AFXRD07S 75-81 ... 10 & 12 Bolt with Staggered Shocks - Black
- AFXRD07Z 75-81 ... 10 & 12 Bolt with Staggered Shocks - Red
- AFXRD82S 82-92 ... 10 Bolt without Staggered Shocks - Black
- AFXRD82Z 82-92 ... 10 Bolt without Staggered Shocks - Red

REAR UPGRADE W/O E-BRAKE

- AFXRDM1S 67 10 & 12 Bolt w/o Staggered Shocks - Black
- AFXRDM1Z 67 10 & 12 Bolt w/o Staggered Shocks - Red
- AFXRDM5S 68-81 ... 10 & 12 Bolt with Staggered Shocks - Black
- AFXRDM5Z 68-81 ... 10 & 12 Bolt with Staggered Shocks - Red
- AFXRDM78S ... 82-92 ... 10 Bolt without Staggered Shocks - Black
- AFXRDM78Z ... 82-92 ... 10 Bolt without Staggered Shocks - Red

FIREBIRD REAR +2 BRAKE CONVERSIONS

**STREET
SERIES**

REAR +2 DISC BRAKE CONVERSION KITS

REAR +2 CONVERSIONS INCLUDE:

- 11" Drilled-Slotted-Zinc Rear Rotors
- Black or Red Rear Powder Coated Calipers
- Caliper Brackets, Spacers, Hardware
- Braided Stainless Rear Hoses
- Weld-On Hose Brackets
- Backing Plates *TRSD Exclusive
- E-Brake Cables

+2 KITS ALSO INCLUDE

- Drilled-Slotted-Zinc Front Rotors
- Black or Red Powder Coated Front Calipers
- Braided Stainless Front Hoses

Right Stuff disc conversions are the most complete kits in the industry at the right price. High quality components, professional packaging, and after-sale support by "hands-on" technicians create an unbeatable value. Get a rear conversion and matching front upgrades with a single part number.

NOTE:
FITS FACTORY
REAR ENDS
CALL FOR CUSTOM
APPLICATIONS



FRONT ROTORS
DRILLED & SLOTTED

WORKS WITH 15" AND LARGER WHEELS

REAR DISC BRAKES + MATCHING FRONT UPGRADES
6 3/16" INSIDE ROTOR DIAMETER - 2.78" CENTER HOLE

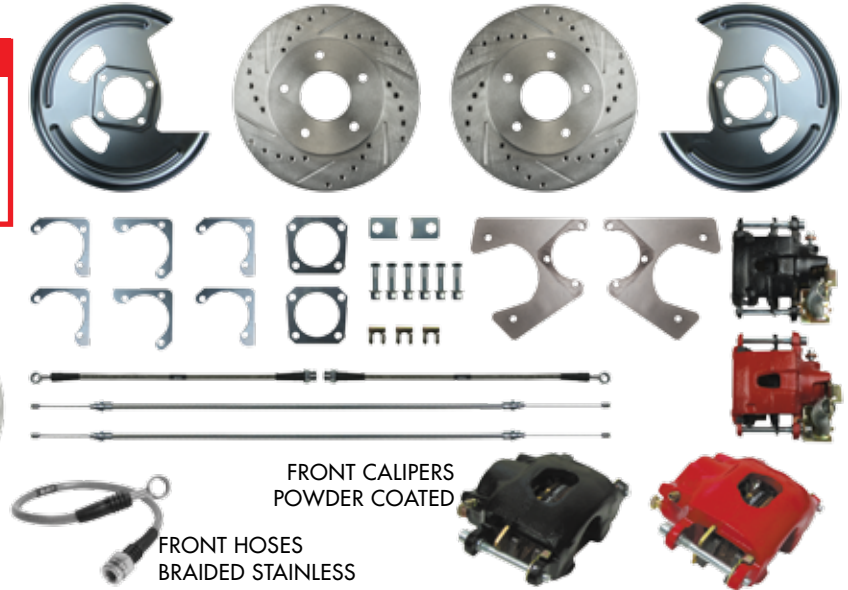

FRONT CALIPERS
POWDER COATED

FRONT HOSES
BRAIDED STAINLESS

REAR +2 KITS WITH E-BRAKE

- F69RD05S 69 Black Calipers, Drilled/Slotted
- F69RD05Z 69 Red Calipers, Drilled/Slotted
- F7ORD06S 70-74 Black Calipers, Drilled/Slotted
- F7ORD06Z 70-74 Red Calipers, Drilled/Slotted
- F75RD07S 75-77 Black Calipers, Drilled/Slotted
- F75RD07Z 75-77 Red Calipers, Drilled/Slotted
- F78RD07S 78 Black Calipers, Drilled/Slotted
- F78RD07Z 78 Red Calipers, Drilled/Slotted
- F79RD07S 79-81 Black Calipers, Drilled/Slotted
- F79RD07Z 79-81 Red Calipers, Drilled/Slotted
- F82RD78S 82-87 Black Calipers, Drilled/Slotted
- F82RD78Z 82-87 Red Calipers, Drilled/Slotted

REAR +2 KITS WITHOUT E-BRAKE

- F69RDM5S 69 Black Calipers, Drilled/Slotted
- F69RDM5Z 69 Red Calipers, Drilled/Slotted
- F7ORDM5S 70-77 Black Calipers, Drilled/Slotted
- F7ORDM5Z 70-77 Red Calipers, Drilled/Slotted
- F78RDM5S 78 Black Calipers, Drilled/Slotted
- F78RDM5Z 78 Red Calipers, Drilled/Slotted
- F79RDM5S 79-81 Black Calipers, Drilled/Slotted
- F79RDM5Z 79-81 Red Calipers, Drilled/Slotted
- F82RDM78S 82-87 Black Calipers, Drilled/Slotted
- F82RDM78Z 82-87 Red Calipers, Drilled/Slotted

AXLE FLANGE DIAGRAMS

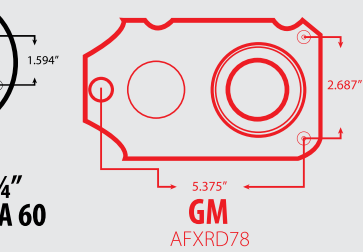
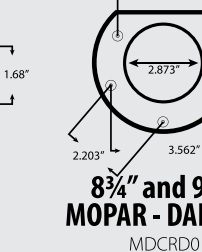
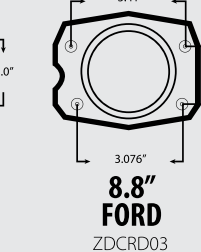
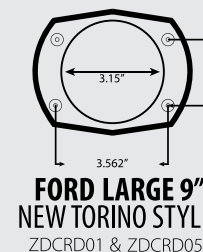
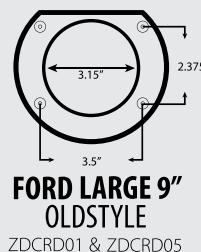
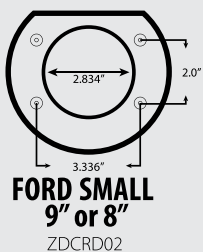
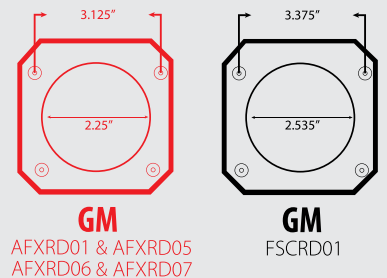
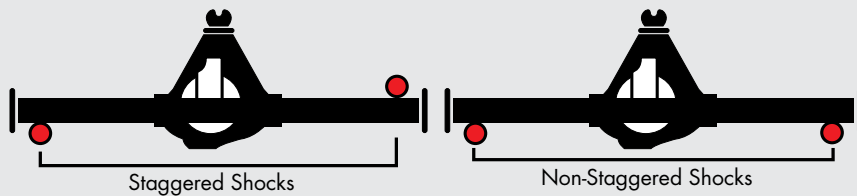

FIREBIRD EZ FIT STOCK STYLE CONVERSIONS



BRAKE•KITS

Fits stock 14" wheel. Bolts to stock drum or disc brake spindles. Minimal offset for better fenderwell clearance. Proprietary rotor.

EZ FIT BRAKE CONVERSION KITS

HALF THE INSTALL TIME
KEEP YOUR FACTORY
14" WHEELS

U.S.A. Made
TIMKEN Bearings

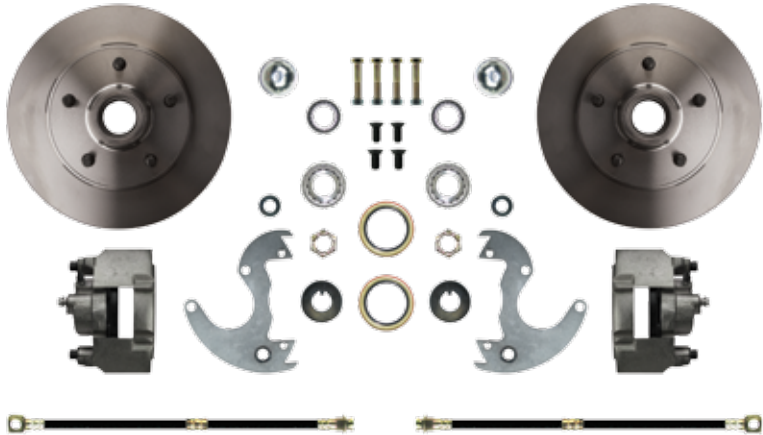

FRONT AT-THE WHEEL KITS

Bolts to your stock drum or disc brake spindles.

Available with standard stock-style rotors or upgraded drilled, slotted & zinc rotors.

FRONT 14" - STANDARD ROTORS

AFXWK1467-69.....Front At-the-Wheel Disc Conversion Kit
AFXSD14.....67-69.....Front Manual Disc Conversion Package
AFXDC1467-69.....Front Power Disc Conversion Package

REAR 14" - STANDARD ROTORS

AFXRD14.....67.....Rear Kit, Non-Staggered
AFXRD13.....68-69.....Rear Kit, Staggered



LOOKING FOR A DIFFERENT BOOSTER + MASTER CYLINDER IN YOUR KIT?

Simply purchase an At-The-Wheel Kit above along with any Booster + Master combo on page 137.



EZ FIT FRONT CONVERSIONS INCLUDE:

- 10" Rotors with Organic Pads
- New Calipers & Brackets
- Banjo Bolts & Copper Washers
- Dust Caps, Castle Nuts & Pins
- Brake Switch Pigtail
- Master Cylinder (Power/Manual Kits)
- Timken Bearings
- Flex Hoses & Kit
- Grease Seals
- Steering Arm Bolts
- Combination Valve
- 9" Booster (Power)

EZ FIT REAR CONVERSIONS INCLUDE:

- Fits 14" wheels
- Uses proprietary rotor
- Built in e-brake (No cables included)



POWER PACKAGE



MANUAL PACKAGE

Packages include At-the-Wheel Disc Conversion Kits & Master Cylinder with Valve (Manual) or Master Cylinder with Booster and Valve (Power).

FRONT 14" - UPGRADE ROTORS

AFXWK14A .. 67-69Front At-the-Wheel Disc Conversion Kit
AFXSD14A..... 67-69Front Manual Disc Conversion Package
AFXDC14A ... 67-69Front Power Disc Conversion Package

REAR 14" - UPGRADE ROTORS

AFXRD14A.....67Rear Kit, Non-Staggered
AFXRD13A.... 68-69Rear Kit, Staggered



FIREBIRD PERFORMANCE SERIES CONVERSIONS

Performance
SERIES

COMPLETE DISC BRAKE CONVERSION KITS

U.S.A. Made
TIMKEN Bearings

NEW

Right Stuff Performance Series disc conversions are the most complete kits in the industry at the right price. Designed for the performance street machine with high quality components, professional packaging, and after-sale support by "hands-on" technicians and many DIY videos at rightstuff create an unbeatable value.

Kits are available as a **Disc Brake Upgrade** that bolts to stock front disc brake spindles, or as an **At-The-Wheel Kit** that includes everything for a front disc brake conversion, and as a **Complete Conversion Kit** which includes everything in the At-The-Wheel Kit with the addition of the master cylinder, booster and prop valve (Power or Manual).

AT-THE-WHEEL CONVERSION KITS INCLUDE:

- 11" Drilled & Slotted Rotors
- Wilwood Dual Piston Calipers
- Caliper Brackets
- Backing Plates
- Timken Bearings
- Castle Nuts & Pins
- Dust Caps
- Forged Spindles
- Organic Pads
- Washers
- Grease Seals
- Spindle Gaskets
- Steering Arm Bolts
- Hardware

COMPLETE CONVERSION KITS ALSO INCLUDE

- Master Cylinder - Chrome or Standard Finish
- Flex Hoses & Clips
- Valve Bracket & Hardware
- Banjo Bolts & Copper Washers
- Combination Valve
- Brake Switch Pigtail
- Pedal Rod Extension

WORKS WITH 15" AND LARGER WHEELS

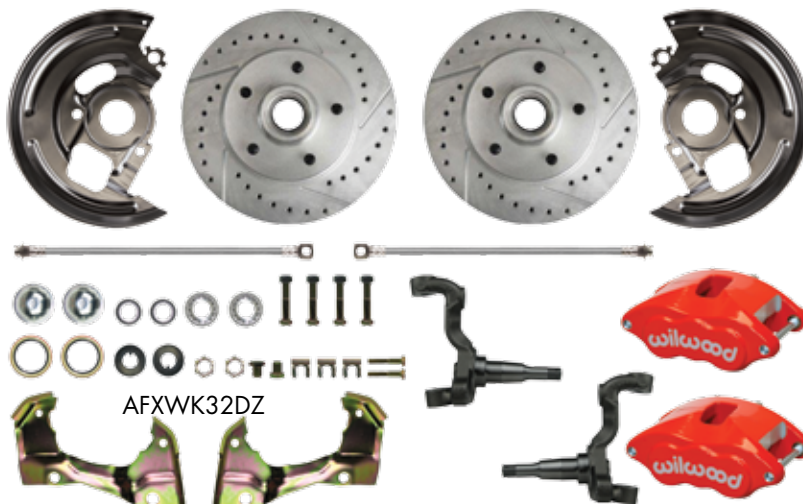

AT-THE-WHEEL KITS



STANDARD PACKAGE

CHROME PACKAGE

Packages include At-the-Wheel Disc Conversion Kits and Chrome or Standard Finish Master Cylinder with Booster and Valve (Power).

AT-THE-WHEEL FRONT DISC KITS

- AFXWK32S..... 67-69 Stock Height - Black Wilwood
- AFXWK32Z 67-69 Stock Height - Red Wilwood
- AFXWK32DS 67-69 2" Drop - Black Wilwood
- AFXWK32DZ 67-69 2" Drop - Red Wilwood

STOCK HEIGHT FRONT KITS

- AFXDC32S..... 67-69 ... Standard Booster/Master - Black Wilwood
- AFXDC32Z 67-69 ... Standard Booster/Master - Red Wilwood
- AFXDC32SX..... 67-69 ... Chrome Booster/Master - Black Wilwood
- AFXDC32ZX..... 67-69 ... Chrome Booster/Master - Red Wilwood

2" DROP FRONT KITS

- AFXDC32DS 67-69 ... Standard Booster/Master - Black Wilwood
- AFXDC32DZ 67-69 ... Standard Booster/Master - Red Wilwood
- AFXDC32DSX .. 67-69 ... Chrome Booster/Master - Black Wilwood
- AFXDC32DZX .. 67-69 ... Chrome Booster/Master - Red Wilwood



DISC BRAKE UPGRADE KITS INCLUDE

(Kit is Designed to Bolt to Stock Disc Brake Spindles)

- Wilwood 2-Piston Aluminum Calipers
- Cross-Drilled & Slotted Zinc Plated Rotors
- Braided Stainless Hoses
- Organic Brake Pads

DISC BRAKE UPGRADE KITS

- RCP69S 1969 Black 2-Piston Wilwood Calipers
- RCP69Z 1969 Red 2-Piston Wilwood Calipers
- RCP70S70-78..... Black 2-Piston Wilwood Calipers
- RCP70Z70-78..... Red 2-Piston Wilwood Calipers
- RCP79S79-81 Black 2-Piston Wilwood Calipers
- RCP79Z79-81 Red 2-Piston Wilwood Calipers

FIREBIRD SIGNATURE SERIES CONVERSIONS



DISC BRAKE CONVERSION KITS



DESIGNED FOR 17\"/>

Bold looks define the Signature Series line of brake kits. Large diameter zinc plated rotors, powder coated calipers, fully machined caliper brackets, & braided stainless brake hoses. Only premium quality components make the grade. We back every kit with industry leading technical support. Signature Series kits are amazing brakes at a great price. Add a "No Brainer" Brake Line Kit for a true bolt-on install.

SIGNATURE SERIES FRONT KIT

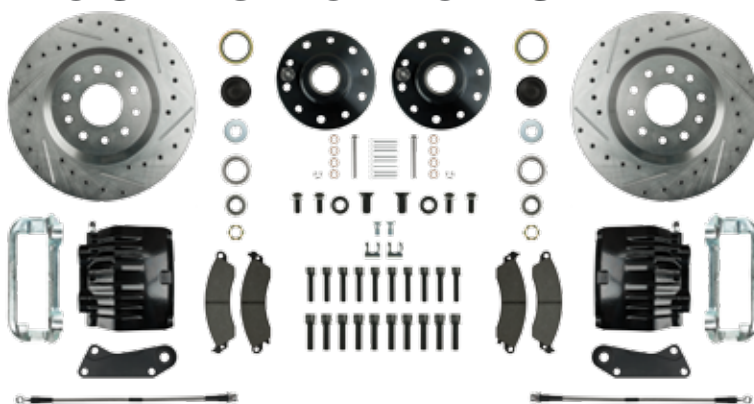

U.S.A. Made **TIMKEN** Bearings



STOCK HEIGHT FRONT KITS

Uses existing drum or disc brake spindles

- AFXWK31CS67-69.....Front Wheel Kit - Black Calipers
- AFXWK31CZ67-69.....Front Wheel Kit - Red Calipers
- AFXSD31CS.....67-69.....Manual Kit - Black Calipers
- AFXSD31CZ.....67-69.....Manual Kit - Red Calipers
- AFXDC31CS67-69.....Power Kit - Black Calipers
- AFXDC31CZ67-69.....Power Kit - Red Calipers

STOCK HEIGHT 4-WHEEL KITS

Stock Height - Non-Staggered Shocks

- AFXWK51CS67-69.....Front Wheel Kit - Black Calipers
- AFXWK51CZ67-69.....Front Wheel Kit - Red Calipers
- AFXSD51CS.....67-69.....Manual Kit - Black Calipers
- AFXSD51CZ.....67-69.....Manual Kit - Red Calipers
- AFXDC51CS67-69.....Power Kit - Black Calipers
- AFXDC51CZ67-69.....Power Kit - Red Calipers

Stock Height - Staggered Shocks

- AFXWK55CS67-69.....Front Wheel Kit - Black Calipers
- AFXWK55CZ67-69.....Front Wheel Kit - Red Calipers
- AFXSD55CS.....67-69.....Manual Kit - Black Calipers
- AFXSD55CZ.....67-69.....Manual Kit - Red Calipers
- AFXDC55CS67-69.....Power Kit - Black Calipers
- AFXDC55CZ67-69.....Power Kit - Red Calipers

2" DROP FRONT KITS

Includes new 2" drop spindles

- AFXWK31DS67-69.....Front Wheel Kit - Black Calipers
- AFXWK31DZ67-69.....Front Wheel Kit - Red Calipers
- AFXSD31DS.....67-69.....Manual Kit - Black Calipers
- AFXSD31DZ.....67-69.....Manual Kit - Red Calipers
- AFXDC31DS67-69.....Power Kit - Black Calipers
- AFXDC31DZ67-69.....Power Kit - Red Calipers

2" DROP 4-WHEEL KITS

Stock Height - Non-Staggered Shocks

- AFXWK51DS67-69.....Front Wheel Kit - Black Calipers
- AFXWK51DZ67-69.....Front Wheel Kit - Red Calipers
- AFXSD51DS.....67-69.....Manual Kit - Black Calipers
- AFXSD51DZ.....67-69.....Manual Kit - Red Calipers
- AFXDC51DS67-69.....Power Kit - Black Calipers
- AFXDC51DZ67-69.....Power Kit - Red Calipers

Stock Height - Staggered Shocks

- AFXWK55DS67-69.....Front Wheel Kit - Black Calipers
- AFXWK55DZ67-69.....Front Wheel Kit - Red Calipers
- AFXSD55DS.....67-69.....Manual Kit - Black Calipers
- AFXSD55DZ.....67-69.....Manual Kit - Red Calipers
- AFXDC55DS67-69.....Power Kit - Black Calipers
- AFXDC55DZ67-69.....Power Kit - Red Calipers

X-TRIM DISC BRAKE CONVERSION UPGRADES



X-TRIM UPGRADE 4-WHEEL KITS

Non-Staggered Shocks

- AFXSD51CSX....67-69... Manual Kit - Black Calipers - Stock Height
- AFXSD51CZX....67-69... Manual Kit - Red Calipers - Stock Height
- AFXDC51CSX ...67-69... Power Kit - Black Calipers - Stock Height
- AFXDC51CZX ...67-69... Power Kit - Red Calipers - Stock Height
- AFXSD51DSX....67-69... Manual Kit - Black Calipers - 2" Drop
- AFXSD51DZX....67-69... Manual Kit - Red Calipers - 2" Drop
- AFXDC51DSX....67-69... Power Kit - Black Calipers - 2" Drop
- AFXDC51DZX ...67-69... Power Kit - Red Calipers - 2" Drop

Staggered Shocks

- AFXSD55CSX....67-69... Manual Kit - Black Calipers - Stock Height
- AFXSD55CZX....67-69... Manual Kit - Red Calipers - Stock Height
- AFXDC55CSX ...67-69... Power Kit - Black Calipers - Stock Height
- AFXDC55CZX ...67-69... Power Kit - Red Calipers - Stock Height
- AFXSD55DSX....67-69... Manual Kit - Black Calipers - 2" Drop
- AFXSD55DZX....67-69... Manual Kit - Red Calipers - 2" Drop
- AFXDC55DSX....67-69... Power Kit - Black Calipers - 2" Drop
- AFXDC55DZX ...67-69... Power Kit - Red Calipers - 2" Drop

Start turning heads with a show finished upper assembly. Manual kits get a chrome plated master cylinder and combination valve with bracket. Power kits also include an 8" dual chrome booster.



X-TRIM UPGRADE FRONT KITS

Stock Height uses existing spindles

- AFXSD31CSX....67-69... Manual Kit - Black Calipers - Stock Height
- AFXSD31CZX....67-69... Manual Kit - Red Calipers - Stock Height
- AFXDC31CSX ...67-69... Power Kit - Black Calipers - Stock Height
- AFXDC31CZX ...67-69... Power Kit - Red Calipers - Stock Height

2" Drop includes new spindles

- AFXSD31DSX....67-69... Manual Kit - Black Calipers - 2" Drop
- AFXSD31DZX....67-69... Manual Kit - Red Calipers - 2" Drop
- AFXDC31DSX....67-69... Power Kit - Black Calipers - 2" Drop
- AFXDC31DZX ...67-69... Power Kit - Red Calipers - 2" Drop



REAR DISC BRAKE CONVERSION KITS

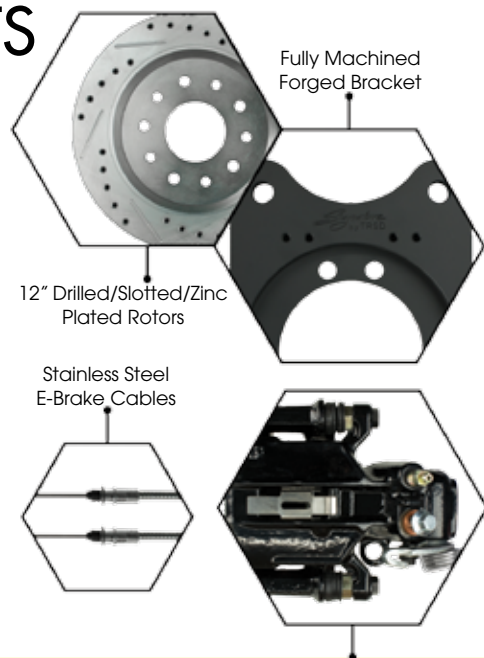
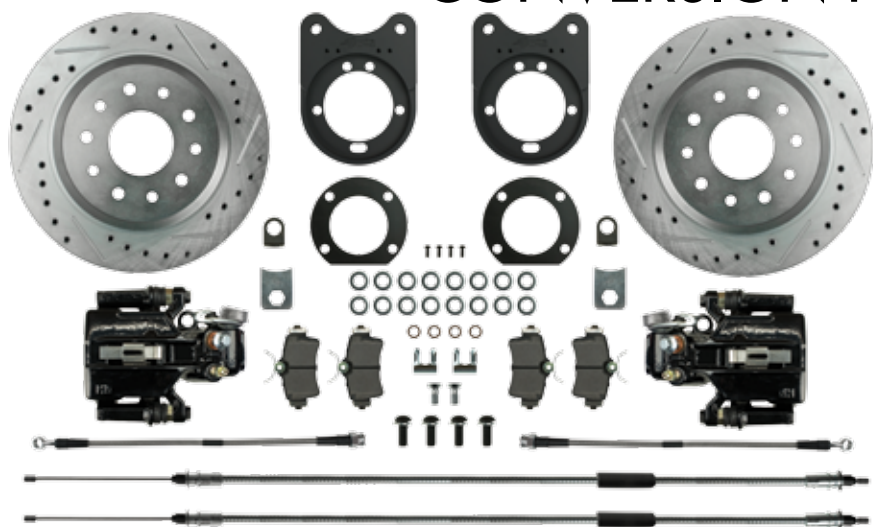

REAR DISC CONVERSION KITS

- AFXRD31S67-69..... 10/12-Bolt Non-Staggered Shocks - Black
- AFXRD31Z67-69..... 10/12-Bolt Non-Staggered Shocks - Red
- AFXRD35S67-69..... 10/12-Bolt Staggered Shocks - Black
- AFXRD35Z67-69..... 10/12-Bolt Staggered Shocks - Red
- AFXRD36S70-74..... 10/12-Bolt Staggered Shocks - Black
- AFXRD36Z70-74..... 10/12-Bolt Staggered Shocks - Red
- AFXRD37S75-81..... 10/12-Bolt Staggered Shocks - Black
- AFXRD37Z75-81..... 10/12-Bolt Staggered Shocks - Red



No Brainer BRAKE LINE KITS FOR DISC CONVERSIONS

Black or Red Calipers

Disc Brake Conversions require special brake lines that fit your new disc conversion setup. See page 154 for your application



No Brainer **BRAKE LINE KITS**

DESIGNED FOR DISC CONVERSIONS

When you add disc brakes to your car you are using a new valve that has different size holes pointing different directions. Even if your lines are brand new or great originals, you are going to have issues trying to use them. Our No Brainer Brake Line Kit fixes all these issues from your master cylinder all the way back to your rear wheel cylinders or rear calipers. We give you all the lines to complete the installation. We also include the rear flex hose and a full clip set to install your lines. Extremely discounted prices and great instructions make this kit a No Brainer.

SIMPLIFY YOUR DISC BRAKE CONVERSION INSTALLATION WITH ALL OF THE BRAKE LINES YOU WILL NEED.

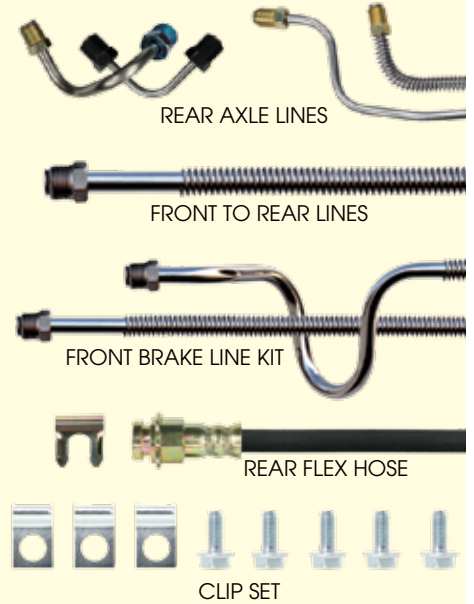

MANUAL - NO VACUUM BOOSTER FRONT DISC/REAR DRUM LINES

- POM67H2 1967OE Steel Brake Line Kit
- PSM67H2 1967Stainless Steel Brake Line Kit
- POM68H2 1968OE Steel Brake Line Kit
- PSM68H2 1968Stainless Steel Brake Line Kit
- POM69H2 1969OE Steel Brake Line Kit
- PSM69H2 1969Stainless Steel Brake Line Kit

POWER - WITH VACUUM BOOSTER FRONT DISC/REAR DRUM LINES

- POP67H2 1967OE Steel Brake Line Kit
- PSP67H2 1967Stainless Steel Brake Line Kit
- POP68H2 1968OE Steel Brake Line Kit
- PSP68H2 1968Stainless Steel Brake Line Kit
- POP69H2 1969OE Steel Brake Line Kit
- PSP69H2 1969Stainless Steel Brake Line Kit

4-WHEEL DISC LINES

- POM67H4 1967OE Steel Brake Line Kit
- PSM67H4 1967Stainless Steel Brake Line Kit
- POM68H4 1968OE Steel Brake Line Kit
- PSM68H4 1968Stainless Steel Brake Line Kit
- POM69H4 1969OE Steel Brake Line Kit
- PSM69H4 1969Stainless Steel Brake Line Kit

4-WHEEL DISC LINES

- POP67H4 1967OE Steel Brake Line Kit
- PSP67H4 1967Stainless Steel Brake Line Kit
- POP68H4 1968OE Steel Brake Line Kit
- PSP68H4 1968Stainless Steel Brake Line Kit
- POP69H4 1969OE Steel Brake Line Kit
- PSP69H4 1969Stainless Steel Brake Line Kit

PROPORTIONING VALVES

DOES YOUR VALVE LOOK LIKE THIS?

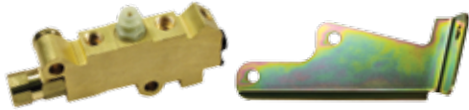

When upgrading to disc brakes or keeping them stock, make sure your proportioning valve is designed for the brake system that is specific to your vehicle.



- PVK71Disc/Drum Proportioning Valve - Brass Finish
- PVK72Disc/Disc Proportioning Valve - Brass Finish
- PVK71CDisc/Drum Proportioning Valve - Chrome Finish
- PVK72CDisc/Disc Proportioning Valve - Chrome Finish



FRONT BRAKE LINE KITS

Front brake line kits consist of all brake lines under the hood. This includes the master cylinder to the distribution, combination or metering valve. The left and right front lines that run to the front flex hoses are also included. Call for individual component pricing. These line kits are for vehicles with factory brake systems.

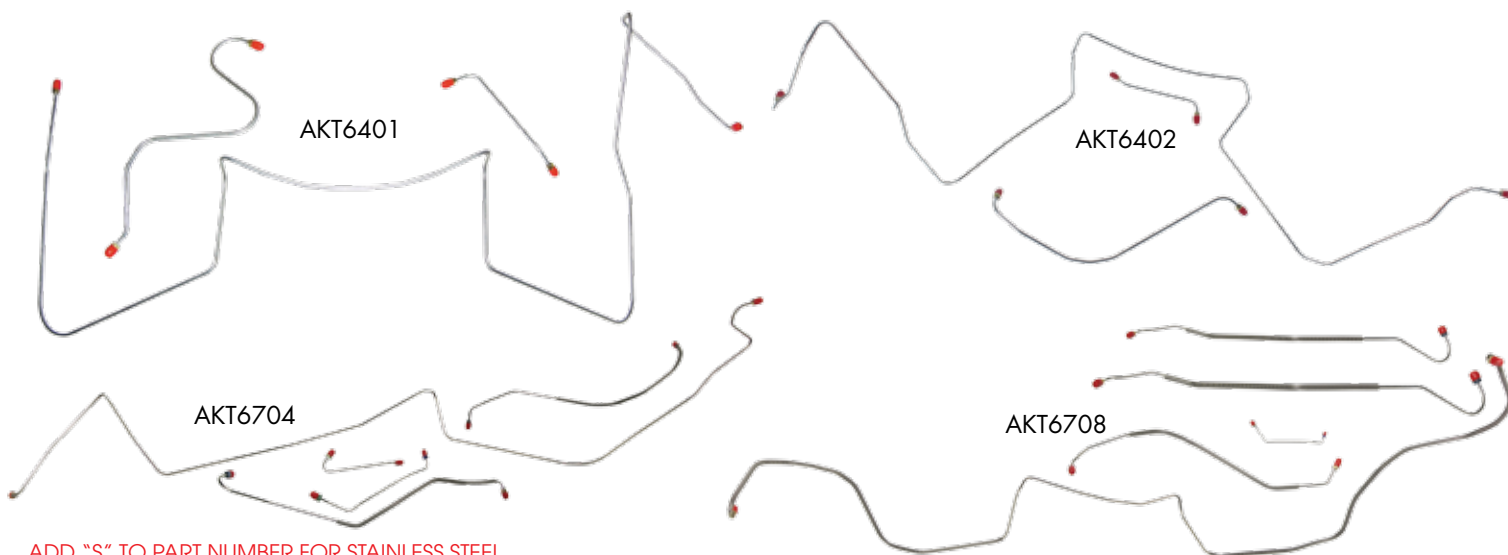

ADD "S" TO PART NUMBER FOR STAINLESS STEEL

AKT6401.. 64-65 ... Standard Drum.....	3-Pc
AKT6402.. 64-65 ... Power Drum.....	3-Pc
AKT6601.....66 Standard Drum.....	3-Pc
AKT6602.....66 Power Drum.....	3-Pc
AKT6701.....67 V-8 Except R/A & H.O. Standard Drum	4-Pc
AKT6702.....67 V-8 Except R/A & H.O. Power Drum	4-Pc
AKT6703.....67 6 Cylinder Power Drum.....	4-Pc
AKT6704.....67 V-8 Except R/A & H.O. Power Disc.....	5-Pc
AKT6705.....67 6 Cylinder, Standard Drum.....	4-Pc
AKT6706.....67 With R/A & H.O. Std. Drum.....	4-Pc
AKT6707.....67 With R/A & H.O. Power Drum...	4-Pc
AKT6708.....67 With R/A & H.O. Power Disc ...	5-Pc

AKT6801.....68 Std. Drum, with Wheel Lines.....	6-Pc
AKT6802.....68 Power Drum, with Wheel Lines...	6-Pc
AKT6803.....68 Power Disc	5-Pc
AKT6805.....68 Standard Disc	5-Pc
AKT6806.....68 Manual Disc	5-Pc
AKT6903.....69 Power Disc	5-Pc
AKT6905.....69 Standard Disc	5-Pc
AKT6901.. 69-72 ... Standard Drum w/Wheel Lines..	6-Pc
AKT6902.. 69-72 ... Power Drum, with Wheel Lines...	6-Pc
AKT7003.....70 Power Disc	5-Pc
AKT7005.....70 Standard Disc	5-Pc
AKT7103.. 71-72 ... Power Disc	4-Pc
AKT7305.. 73-75 ... Power Disc	5-Pc
AKT7401.....74 Power Drum, Ventura II.....	4-Pc
AKT7405.....74 Power Disc, Ventura.....	4-Pc

FRONT TO REAR BRAKE LINES

Front to rear brake lines go from the distribution, combination or metering valve along the length of the vehicle to the rear flex hose. Lines are manufactured in 1 or 2 pieces based on factory specifications.

*USES HOLD-OFF VALVE SHOWN ON PAGE 158

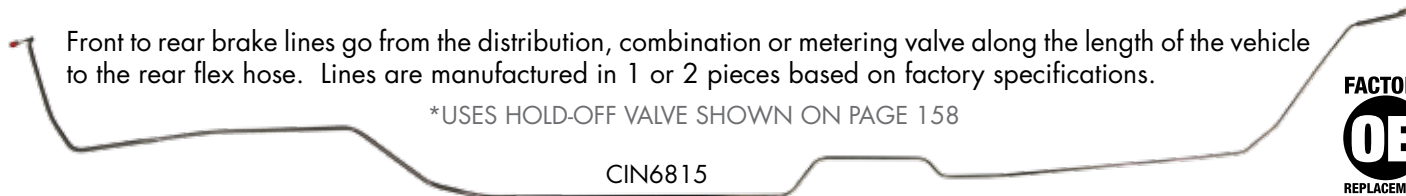

ADD "S" TO PART NUMBER FOR STAINLESS STEEL

CIN6402.... 64-65 Convertible
CIN6503.... 64-65 Hardtop
CIN6605.....66 Hardtop
CIN6606.....66 Convertible
AIN6701.....67 Hardtop
AIN6702.....67 Convertible
CIN6801.....68 Hardtop
CIN6802.....68 Convertible

CIN6815.....69 Hardtop
CIN6816.....69 Convertible
AIN7021.....70 Hardtop, Disc Only *, 2-Piece.
AIN7022.....70 Convertible, Disc Only *, 2-Piece.
CIN7002.....70 Wagon
CIN7131.... 71-72 Hardtop (Also 70 Drum)
CIN7132.... 71-72 Convertible (Also 70 Drum)
AIN7305.... 73-75 Power Disc
AIN7401.... 73-77 Power Disc
AIN7402.....74 Ventura II

REAR AXLE BRAKE LINES

Rear axle brake lines include a pair of lines that run across the rear axle housing. These lines connect the wheel cylinders or calipers to the flex hose in the middle of the rear end. These lines work with original housings that use factory brakes. Modifications such as rear disc brakes or narrowed rear ends will likely require special lines. Call for more information.

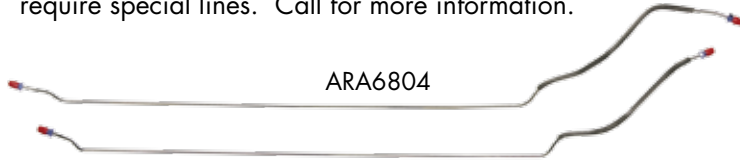

ADD "S" TO PART NUMBER FOR STAINLESS STEEL

- CRA640364-65.... All Cars
- ARA6602 66 All Cars
- ARA6702 67 All Cars
- ARA680468-72.... All Cars
- ARA7401 74 Ventura II
- ARA740273-77.... All Cars, Exc. Ventura II

DISC BRAKE CALIPER LINES

Front disc caliper lines connect the front flex hoses to the calipers. They were typically used on 4 piston calipers in the late 1960's. Several fitting sizes were available from the factory. Please verify fitting sizes before ordering as rebuilt calipers may not match the originals.



ADD "S" TO PART NUMBER FOR STAINLESS STEEL

- AFC6701 ...67 ... 3/8" x 3/8" with Armor..... 2 Pcs.
- AFC6702 ...67 ... 3/8" x 1/2" Right Port, 3/8" x 7/16" Left Port with Armor..... 2 Pcs.
- AFC6801 ...68 ... 3/8" x 3/8" 2 Pcs.
- AFC6802 ...68 ... 1/2" Right Port, 7/16" Left Port... 2 Pcs.

DISC BRAKE CLIPS

Brake line clip sets contain all the clips needed to fasten the brake tubes to the frame or body of the car. Individual clips and fasteners are available on pages 284-285.



- ACS01564-65..... Complete Set, 9-Piece
- ACS01666-67..... Except RA & HO, 9-Piece
- ACS01766-67..... with RA & HO, 10-Piece
- ACS01868-69..... Complete Set, 8-Piece
- ACS019 70 Complete Set, 8-Piece
- ACS02071-72..... Complete Set, 8-Piece

FRONT FLEX HOSES

Front flex hoses provide a flexible connection from the body or frame to the front calipers or wheel cylinders as they move during suspension travel. Choose between O.E. rubber or braided stainless steel. All of our hoses are D.O.T. approved. Hoses are priced individually.

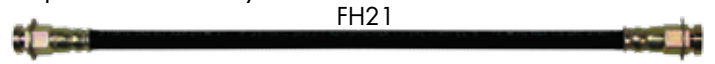

ADD "S" TO PART NUMBER FOR STAINLESS STEEL

- FH27 64-67 Drum
- FH26 67 Front Disc
- FH21 68-72 Drum, Also 68 Disc
- FH20 69-71 Disc
- FH24 72 Disc

REAR FLEX HOSES

Rear flex hoses carry brake fluid between the body of the car and the rear. Hoses are available in O.E. rubber and braided stainless steel. 'T' blocks are attached whenever factory correct. All of our hoses are D.O.T. approved. Prices are per hose.



ADD "S" TO PART NUMBER FOR STAINLESS STEEL

- FH17 64-65 All Cars
- FH28 66-67 All Cars
- FH25 68 All Cars
- FH06 69-71 All Cars
- FH15 72 All Cars

BRAKE HOSE BRACKETS

These brackets and hardware are used to secure flex hoses to various parts of the vehicle. Front brackets are sold in pairs.

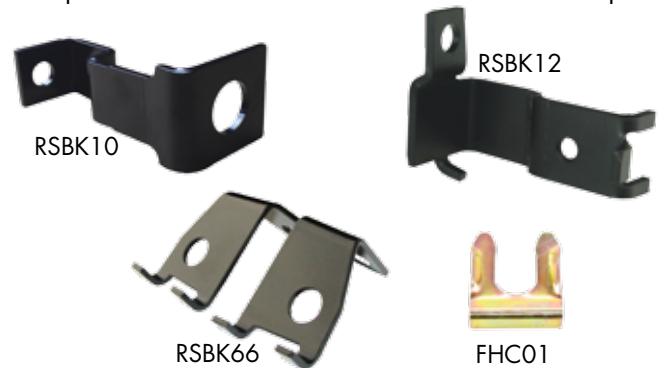

- CW6901 69 Copper Washer
- FHC01 All Correct Gold Cadmium Plated C Clips
- RSBK10 64-65 Rear Hose Bracket, Used with Screw On Block
- RSBB01 64-68 Rear Hose Brass 'T' Block
- RSBK02 66-67 Rear Hose Bracket, Used with Screw On Block
- RSBK66 68 4 Piston Inlet Line Brackets
- RSBK70 68-72 Front Hose Bracket, Disc Only
- RSBK12 68-72 12 Bolt Rear Hose Bracket

E-BRAKE CABLES

Parking brake cable sets contain all the individual cables and hardware needed to restore the system. Front, rear, & intermediate cables are also sold individually. Sold in O.E. mild steel and stainless steel. While supplies last.



SEE PAGE 286 FOR PICTURES OF E-BRAKE HARDWARE

ADD "S" TO PART NUMBER FOR STAINLESS STEEL

• E-Brake Cable Kits

RSBCA01..... 64-67Excluding Turbo 400
 RSBCA02..... 67-72Turbo 400
 RSBCA03..... 68-72Turbo 350 & 3-Speed
 RSBCA04..... 68-72Turbo 400
 RSBCA18..... 70.....Wagon
 RSBCA15..... 68-724 Speed
 RSBCA16..... 73-77Turbo 350*
 RSBCA17..... 73-77Turbo 400*

• Front Brake Cables

EBC7001..... 64-67GTO, Excl. Turbo 400
 EBC7024..... 64-67GTO, Turbo 400
 EBC7010..... 68-72GTO, Turbo 400, 4-Speed
 EBC7011..... 68-72GTO, T-350, 3-Speed

• Rear Brake Cables

EBC9001..... 64-67GTO, Excl. Turbo 400
 EBC9026..... 64-67GTO, Turbo 400
 EBC9007..... 68-72GTO, All

• Intermediate Brake Cables

EBC8001..... 64-67GTO, Excl. Turbo 400
 EBC8005..... 64-67GTO, Turbo 400
 EBC8010..... 68-72GTO, Turbo 400, 4-Speed
 EBC8011..... 68-72GTO, T-350, 3-Speed

• E-Brake Hardware

EBH3001..... 64-77 Olive Green Center Pull
 EBH3002..... 64-77 Center to Rear Silver Connector
 RSCLP23..... 64-77 Parking Brake Clip - Black
 EBH2006..... 64-67 Front Hook
 EBH1001..... 64-77 Jam Nut
 EBH2007..... 64-67 Side Hook Excl. T-400
 EBH2002..... 67 Side Hook T-400
 EBH1003..... 64-67 Silver Washer Excl. T-400
 EBH1004..... 64-67 Self Tapper Excl. T-400
 EBH2005..... 68-72 Silver Rear Hook
 EBH2013..... 68-72 7-3/8" Hook T-400
 EBH2002..... 70 Side Hook, Wagon Excl. T-400
 EBH2006..... 70 Front Hook, Wagon Excl. T-400
 EBH2003..... 73-77 12" Silver Hook

WHEEL CYLINDERS

Wheel cylinders are priced individually. Hardware is not included.



WC02



WC01

WC07..... 64-66 Rear
 WC01..... 64-67 Left Front
 WC02..... 64-67 Right Front
 WC03..... 67-72 Rear
 WC05..... 68-72 Left Front
 WC06..... 68-72 Right Front

DRUM BRAKES

Brake drums are sold individually.



BD01 67-71Rear Drum, Finned

CALIPER BRACKETS

Yellow zinc plating provides corrosion protection on these reproduction brackets.

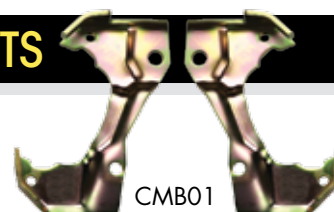

CMB01

CMB06 67-684 Piston Caliper Brackets (pr)
 CMB01 69-72Single Piston Caliper Brackets (pr)

BACKING PLATES

Often called dust shields, these plates provide some level of protection from road debris.



DBBP01

DBBP03

DBBP03 67-684 Piston Backing Plates (pr)
 DBBP01 69-72Single Piston Backing Plates (pr)

GTO/LEMANS FRONT BRAKES & SPINDLES

BRAKE CALIPERS

New calipers are supplied loaded with pads*, banjo bolts and copper washers. No core charge applies. Mounting pins are provided when applicable. Black and Red powder coating options provide a smooth, finished look that is unaffected by leaking brake fluid. *Rebuild and new 4 piston calipers do not include pads or hardware. Core charges apply as noted.

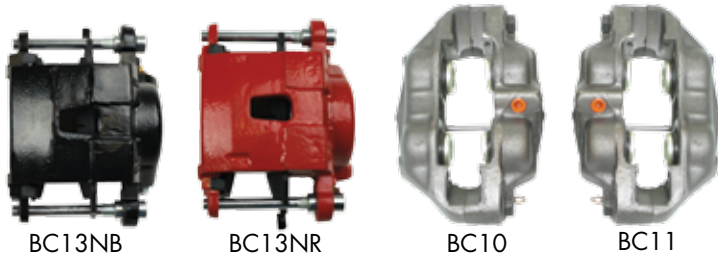

- BC1067-68..... 4 Piston, Left, with Exchange
- BC10C67-68..... Core Charge
- BC1167-68..... 4 Piston, Right, with Exchange
- BC11C67-68..... Core Charge
- CB6901 69 Caliper Bolts, Single Piston (ea.)
- BC14N.....69-72..... Left Front, New with pads
- BC15N.....69-72..... Right Front, New with pads
- BC141569-72..... Red or Black Powdercoat (pr)
- BC080973-77..... Red or Black Powdercoat (pr)
- BC12N.....78-81..... Left Front, New with pads
- BC13N.....78-81..... Right Front, New with pads
- BC121378-81..... Red, Black, or Powdercoat (pr)

DISC BRAKE PADS

Brake pads are sold in sets of four. Our base line is a midgrade standard offering. Step up to the Silencer Professional line for less dust, quieter braking, and longer pad life.



SILENCER PROFESSIONAL

- DPO167-68..... 4 Piston Caliper Pads (2 pr) - Standard
- DPO269-77..... Single Piston Front Pads (2 pr) - Silencer
- DPO2P69-77..... Single Piston Front Pads (2 pr) - Standard
- DP2378-81..... Single Piston Front Pads (2 pr) - Silencer
- DP23P78-81..... Single Piston Front Pads (2 pr) - Standard
- DP2364-81..... Rear Pads (2 pr), with RSD Rear Disc - Silencer
- DP23P64-81..... Rear Pads (2 pr), with RSD Rear Disc - Standard

BRAKE ROTORS

Brake rotors are shipped with bearing races installed. A Drilled-Slotted-Zinc Plated option is available on select rotors.



- BR01C.....67-68..... Front Rotor, 4 Piston, 1 Pc Design
- BR69C.....67-69..... Front Rotor, 4 Piston, 2 Pc Design
- BR02C.....69-72..... Front Rotor, 1 Pc Design
- BR03C.....73-77..... Front Rotor
- Call Us! 78 Front Rotor
- BR22C.....79-81..... Front Rotor

MINI KITS

Mini kits include a pair of spindles, caliper brackets, & backing plates. Kits are a great value to freshen up the front end on a restoration project, or to build out a drum to disc brake conversion.

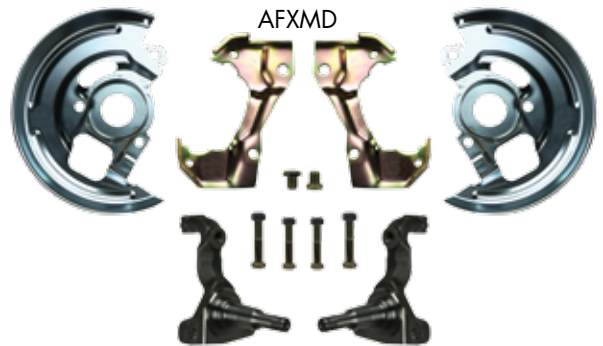

- AFXMD69-72..... Mini Conversion Kit, Includes: Spindles, Backing Plates, Caliper Brackets
- AFXMD469-72..... 2" Drop, Single Piston Calipers
- AFXMD367-68..... Standard Height, 4 Piston Piston Calipers

SPINDLES

Our spindles are forged steel with precision CNC machining. Two hard to find caliper mounting bolts are included with each pair of spindles. 2" drop installations require caliper bracket and backing plate modifications. All listings are for disc brake systems. Call for drum brake applications.



- DBSP01 67-72 Disc Brake Spindles with Large Bolts (pr)
- DBSP04 67-72 2" Drop Disc Brake Spindles with Bolts (pr)

GTO/LEMANS BOOSTERS & MASTER CYLINDERS

SLIMLINE BOOSTER MASTER COMBOS

J81315672

The slimline combos offer clean lines and plenty of power in a small package. The 8" dual is our favorite. Mounting brackets included.



J81315672 TOP VIEW

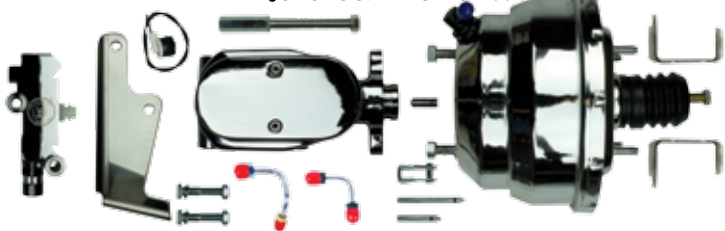

- G81310971 64-72 Gold 8" Dual, Disc/Drum
- J81315171 64-72 Chrome 8" Dual Disc/Drum
- G81310572 64-72 Gold 8" Dual, Disc/Disc
- J81315672 64-72 Chrome 8" Dual Disc/Disc
- G91020971 64-72 Gold 9" Single, Disc/Drum
- G91020572 64-72 Gold 9" Single, Disc/Disc

SLIMLINE BOOSTERS

Slimline boosters pack a lot of punch in a small, sleek package. Dual diaphragm versions provide 25% - 35% more assist than their single diaphragm equivalent. The 8" dual is our most popular for clearing big blocks while providing plenty of assist for two or four wheel disc brake systems. Mounting brackets included.



- RPB7137 64-72 7" Dual, Standard Gold
- RPB7137C 64-72 7" Dual, Chrome Plated
- RPB7137S 64-72 7" Dual, Polished Stainless
- RPB8131 64-72 8" Dual, Standard Gold
- RPB8131C 64-72 8" Dual, Chrome Plated
- RPB8131S 64-72 8" Dual, Polished Stainless
- RPB9102 64-72 9" Single, Standard Gold

DELCO BOOSTER MASTER COMBOS

Factory style for 67-72 GM. Can be tight on big block cars. The 11" is our most popular booster. Available with or without Delco stamping. Brackets included.



G91210971



- G91210971 64-72 Gold 9" Single Disc/Drum
- J91215171 64-72 Chrome 9" Single, Disc/Drum
- G91210572 64-72 Gold 9" Single Disc/Disc
- J91215672 64-72 Chrome 9" single, Disc/Disc
- FDC001 69 11" Single, Factory Correct Disc/Drum
- G10030971 67-72 Gold 11" Single Disc/Drum
- J10035171 67-72 Chrome 11" Single, Disc/Drum
- G10030572 67-72 Gold 11" Single Disc/Disc
- J10035672 67-72 Chrome 11" Single, Disc/Disc

DELCO BOOSTERS

Reproductions based on original factory units. GM licensed & feature a Delco Moraine stamping. This logo is available right side up and upside down. Unstamped boosters are of identical quality, but less expensive without the licensing fees. Includes mounting brackets.

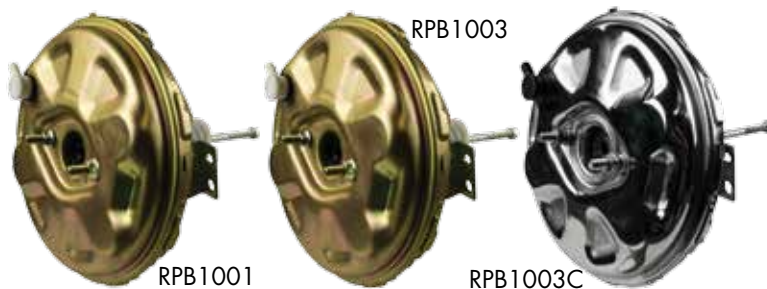

- RPB9121 64-72 9" Single Gold
- RPB9016 64-72 9" Standard Gold, with Delco Stamping
- RPB9121C 64-72 9" Single Chrome
- RPB1001 64-72 11" Single, Gold with Delco Stamp
- RPB1008 67-72 11" Single, Gold Upside Down Stamp
- RPB1003 67-72 11" Single Gold
- RPB1003C 67-72 11" Single Chrome

GTO/LEMANS MASTER CYLINDERS & VACUUM

MASTER CYLINDERS

Most master cylinders are completely new units with no core charge. A deep cylinder pocket with a removable plug provides compatibility with manual brakes as well as power-assisted applications.



- DBMC0864-65... Drum, Single Outlet, 1" Bore
- DBMC0967-70... Power Disc, 1-1/8" Bore
- DBMC1167-69... Power Disc, with Bleeders, 1-1/8" Bore, Deep, Exact Repo for '69, Delco Licensed
- DBMC1667-69... Power Disc, with Bleeders, 1 1/8" Bore, Deep, Same as DBMC11 without Casting Marks
- DBMC09C...67-69... 1-1/8" Bore, Chrome
- DBMC05C...67-69... 1" Bore, 4 Wheel Disc, Chrome
- DBMC51C...67-69... 1-1/8" Bore, Slimline Flat Top, Chrome
- DBMC56C...67-69... 1" Bore, Slimline Flat Top, Chrome
- DBMC0169-75... Power Disc, 1-1/8" Bore, Shallow
- DBMC1970..... Power Disc, 1-1/8" Bore, Square with Bleeders

QUADRAJET VACUUM LINES

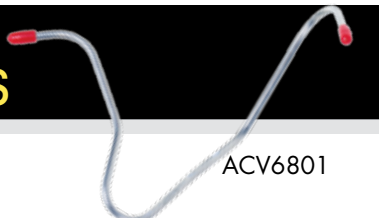

- ACV680168-69... Quadrajets Vacuum Line - OE Steel
- ACV6801S..68-69... Quadrajets Vacuum Line - Stainless

AIR CLEANER TUBES

Valve cover to air cleaner tubes.

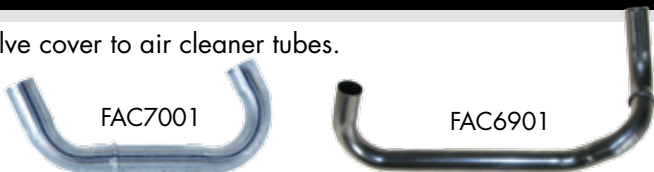

- FAC680168-74..... without Ram Air, RH Valve Cover
- FAC690169-70..... Ram Air, RH Valve Cover
- FAC700171-72..... Ram Air, RH Valve Cover
- FAC710171-75..... TA with Shaker Hood

VALVES & BLOCKS

We offer a full line of metering blocks, proportioning valves, distribution blocks and combination valves for factory drum and disc brake applications.

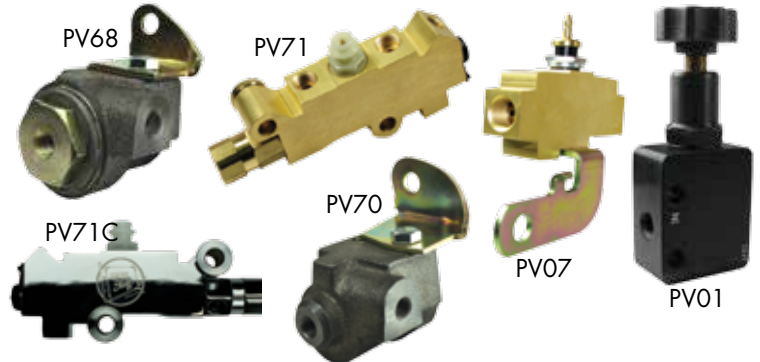

- PV01 All Adjustable Valve
- PV67C..... 67 Hold-Off Valve with Bracket
- PV06 67-69..... Distribution Block
- PV68 68-69..... Hold-Off Valve with Bracket
- PV70 70 Hold-Off Valve with Bracket
- PV07 70-72..... Distribution Block with Bracket
- PV71 71-77..... Disc/Drum Combination Valve, Brass
- PV71C..... 71-77..... Disc/Drum Combination Valve, Chrome
- PV72 71-77..... Disc/Disc Combination Valve, Brass
- PV72C..... 71-77..... Disc/Disc Combination Valve, Chrome
- PVB78 71-72..... Disc Brake Valve Bracket
- AMB7001..... Proportioning Valve

POWER VACUUM LINES

Power brake vacuum lines connect the intake manifold fitting to the rubber hose that runs to the power brake booster. Brackets are included as noted.

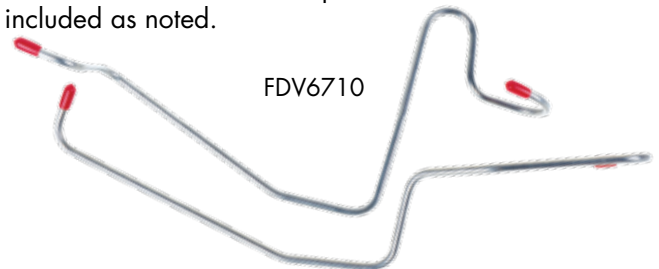

- FDV6706 67..... 6 Cylinder, Quadrajets
- FDV6710..... 67..... 400
- FDV6910..... 69..... 400, 4 BBL
- ABV6401 64-66 Tri-Power
- ABV6501 65-66 8 Cyl., with 2 or 4 BBL
- ABV6502 65-67 with 2 or 4 BBL

POWER STEERING LINES

Power steering lines can be either pressure or return feeds in a power steering system.



- ADD "S" TO PART NUMBER FOR STAINLESS STEEL
- APS6901 67-69 Power Steering Return Lines
- APS8100..... 70-81 Power Steering Return Lines

MAIN FUEL LINES

Main lines carry fuel from the tank in the rear of the car to the fuel pump or rail in the front. They are available in 3/8" and 5/16" tubing based on factory specifications. Multiple piece sets are noted. Call for 1/2" lines.

AGL7011

ADD "S" TO PART NUMBER FOR STAINLESS STEEL

AGL641164-66..... 5/16" Hardtop
 AGL643164-66..... 3/8" Hardtop
 AGL641264-66..... 5/16" Convertible
 AGL6711 67 5/16" Hardtop
 AGL6731 67 3/8" Hardtop
 AGL6712 67 5/16" Convertible
 AGL6715 67 5/16" 6 Cylinder, Hardtop
 AGL6716 67 5/16" 6 Cylinder, Convertible
 AGL681168-69..... 3/8" Hardtop without ECS
 AGL681268-69..... 3/8" Convertible without ECS

AGL701170-72..... 3/8" Hardtop without ECS
 AGL701270-72..... 3/8" Convertible without ECS
 AGL701570-72..... 3/8" Hardtop with ECS
 AGL701670-72..... 3/8" Convertible with ECS
 AGL7005 70 3/8" Wagon
 AGL7401 74 3/8" Main Fuel Line
 AGL741173-74..... 3/8" Ventura II, 2 Pcs.
 AGL730573-75..... 3/8" Main Line
 AGL7707 77 400 ci Main Fuel Line
 *ECS=Emission Control System

RETURN FUEL LINES

Return lines carry excess fuel from fuel pump or fuel filter back to the tank. Not all vehicles were equipped with a return line. They are typically made of 1/4" diameter tubing. Multiple piece sets are noted..

AGL7018

*ECS=Emission Control System

ADD "S" TO PART NUMBER FOR STAINLESS STEEL

AGL641364-66..... 1/4" Hardtop
 AGL641464-66..... 1/4" Convertible
 AGL6713 67 1/4" Hardtop, Use With 6711
 AGL6714 67 1/4" Conv, Use With 6712
 AGL681368-69..... 1/4" Hardtop
 AGL681468-69..... 1/4" Convertible
 AGL701370-72..... 1/4" Hardtop, without ECS,
 Use With 7011, 2-Piece

AGL701470-72..... 1/4" Convertible, without ECS,
 Use With 7012
 AGL701770-72..... 1/4" Hardtop, with ECS,
 Use With 7015
 AGL701870-72..... 1/4" Convertible, with ECS,
 Use With 7016
 AGL7006 70 Wagon, Return Line, 2-Piece
 AGL7402 74 1/4" Return Line
 AGL741273-74..... 1/4" Return Line, Ventura II, 2-Pc
 AGL730673-75..... 1/4" Return Line

FUEL VAPOR RETURN LINES

Emission control systems use these 5/16" lines to handle fuel vapors. Some vehicles use a single front to rear line. Others utilize a charcoal canister and require 3 or 4 additional small lines. Multiple piece sets are noted.

*ECS=Emission Control System

ADD "S" TO PART NUMBER FOR STAINLESS STEEL

AEM6901.... 69..... Hardtop
 AEM7001.... 70..... Hardtop
 AEM7004.... 70..... Convertible
 AEM7101..71-72 .. Hardtop
 AEM7102..71-72 .. Convertible
 AGL7307 ..73-75 .. 5/16" Vapor Line
 AGL7403 74..... 5/16" Vapor Line, With ECS

FUEL LINE CLIPS

Fuel line clips hold tubing to the frame or body of the car. Fasteners are included as noted. See page 284-285 for individual clips.

ACS024

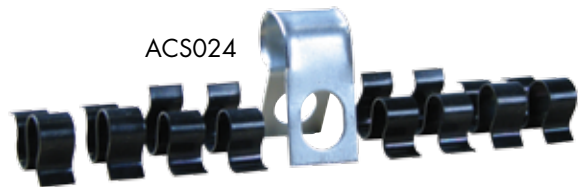

ACS023 ... 64-67 ... with 5/16" Fuel Line & 1/4" Return
 ACS024 ... 64-67 ... with 3/8" Fuel Line & 1/4" Return
 ACS025 ... 68-69 ... with 3/8" Fuel Line & 1/4" Return
 ACS02670 with 3/8" Fuel Line & 1/4" Return
 ACS02770 with 3/8" Fuel Line Only
 ACS028 ... 71-72 with 3/8" 1/4" & 5/16" EMS
 ACS029 ... 71-72 with 3/8" Fuel Line

FUEL PUMP TO CARB LINES

Fuel pump to carburetor lines connect the fuel pump to the carburetor. Brass blocks and fittings are included as noted. These lines are intended to work only with factory pump, motor, intake and carburetor combinations.

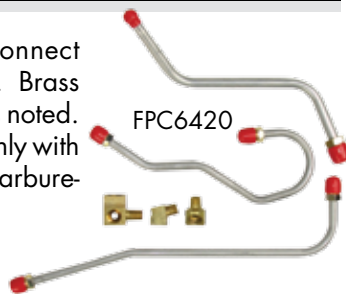

ADD "S" TO PART NUMBER FOR STAINLESS STEEL

- PPC6304 .. 63-65 ... 326, 2 BBL, Aluminum
- FPC640164 8 Cylinder, 4 BBL, Aluminum
- FPC6420 .. 64-65 ... Tri-Power, 3 Alum. Lines, Front Fuel Block, 45 Degree and 105 Degree Fittings
- FPC6423 .. 64-65 ... Lines Only, Tri-Power, Aluminum
- FPC650165 8 Cylinder, 4 BBL, Aluminum
- FPC660166 8 Cylinder, 4 BBL, Short 90 Deg. Tube
- FPC6601B ...66 FPC6601 Mounting Bracket
- FPC662066 Tri- Power, 3 Alum. Lines, Front Fuel Block & Two 105 Degree Fittings
- FPC662266 Lines Only From FPC6620, Aluminum
- FPC670467 GTO, 400, 4BBL
- FPC670667 6 Cylinder, Quadrijet
- FPC672067 8 Cylinder, 4 BBL without Vent Line
- FPC672167 8 Cyl, 4 BBL HO Kit, 3 Lines with Vent
- FPC6723 .. 67-71 ... 2 BBL Bottom Outlet Pump
- FPC672467 326, 2BBL
- FPC682068 4 BBL
- FPC692069 4 BBL
- FPC692169 Ram Air 4
- FPC692269 Ram Air V Fuel Line Kit
- FPC702070 400, 4 BBL
- FPC702170 Ram Air 3, Late Pump
- FPC702270 Ram Air 4
- FPC702370 455, 4 BBL
- FPC712071 400 or 455, 4 BBL
- FPC7220 .. 71-72 ... 400 or 455, 4 BBL, with HO



TRANSMISSION COOLER LINES

Transmission cooler lines are sold as pairs. Be sure to verify the type of transmission in your project before ordering. These lines are intended to work only with factory motor, transmission, and radiator combinations.

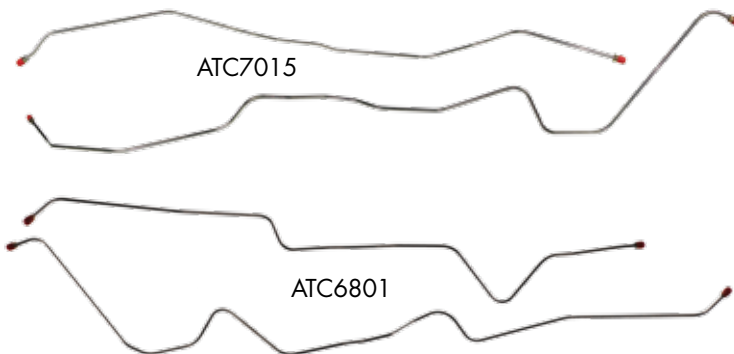

- ATC6411 ...64-66... Powerglide, 3/8" Lines
- ATC6715 67 Turbo 400 & Powerglide, Except H.O.
- ATC6716 67 Turbo 400 H.O. Only
- ATC6801 68 ST300 Buick 2 Spd.
- ATC7003 ...68-72... Turbo 350
- ATC7015 ...68-72... Turbo 400
- ATC7305 ...73-75... Turbo 400

TRANSMISSION VACUUM LINES

Transmission vacuum lines connect automatic transmissions to intake vacuum.

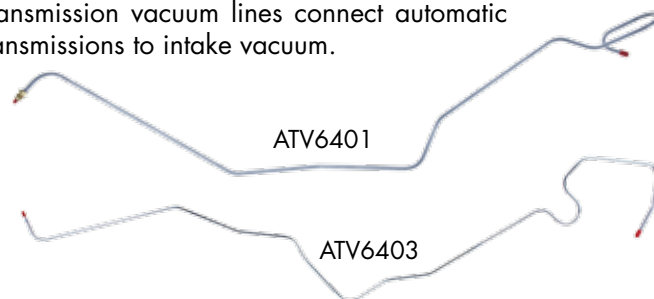

- ATV6403 64-66 with Tri-Power
- ATV6401 64-67 with 2 or 4 BBL, Powerglide
- ATV6703 67 with Turbo 400
- ATV6704 67 GTO 335HP, Except H.O., T400
- ATV7005 68-72 with Turbo 400
- ATV7001 70 Wagon

THERMAL CHOKE LINES

Thermal choke lines carry heat from the exhaust system to the choke coil on the carburetor. Some applications route thru the intake manifold on their way to the carburetor.

- FCH6401 64 Tri-Power
- FCH6402 64 4 BBL
- FCH6501 65 Tri-Power
- FCH6502 65-66... 4 BBL

SUSPENSION COMPONENTS

UPPER & LOWER BALL JOINTS

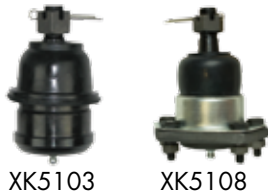

XK5103

XK5108

XK5103 64-72 Lower
 XK5108 64-72 Upper
 XK6145 73-81 Lower
 XK5208 73-81 Upper

UPPER & LOWER CONTROL ARM BUSHING KITS



XK5196

**COMING
IN 2017**

XK5144 64-68 Lower, Circular Hole
 XK5149 69-72 Lower, Oval Hole
 XK5196 64-72 Upper
 XK6108 73 Upper
 XK6109 73-77 Lower
 XK6144 74-77 Upper
 XK6176 78-81 Upper
 XK6177 78-81 Lower

INNER & OUTER TIE RODS & SLEEVES



XES681N

XES681N 64-65 Inner
 XES681N 68-70 Inner
 XES333RL 64-70 Outer
 XES2032S 64-70 Adjusting Sleeve
 XES2032S 78-81 Adjusting Sleeve
 XES2034RL 78-81 Inner
 XES2033RL 78-81 Outer
 XES2004S 71-77 Adjusting Sleeve
 XES2020RL 73-77 Inner
 XES427R 73-77 Outer

STEERING ARMS

DBSA01 64-72 Steering Arm

SUSPENSION KITS

Standard rubber kits meet O.E. specifications. Polyurethane kits provide better handling and a firmer ride. Poly kits include upgraded control arm bushings, sway bar bushings, and sway bar links. Pre-packaged kits offer huge savings over individual suspension parts. Most kits include the following:

- Lower Ball Joints (2)
- Upper Ball Joints (2)
- Lower Ctrl. Arm Bushings (4)
- Upper Ctrl. Arm Bushings (4)
- Inner Tie Rods (2) (Extra Value)
- Sway Bar Link Kits (2)
- Tie Rod Adj. Sleeves (2)
- Sway Bar Bushings (2)
- Outer Tie Rods (2)



CSK6501 ... 64-68 ... Kit, Circular Hole in Control Arm, 22-Piece*.
 CSK6501U ... 64-68 ... Kit, Circular Hole in Ctrl. Arm, 22-Piece (Poly)*
 CSK7001 ... 64-72 ... Kit, Oval Hole in Control Arm, 22-Piece
 CSK7001U ... 64-72 ... Kit, Oval Hole in Control Arm, 22-Piece (Poly)
 CSK7301 73 Kit with Mounting Tabs on Sway Bar
 CSK7302 73 Kit without Mounting Tabs on Sway Bar with
 1", 1-1/16", 1-1/8" Sway Bar
 CSK7303 73 Kit without Mounting Tabs on Sway Bar with
 1 3/16" or Greater Sway Bar
 CSK7401 ... 74-75 ... Front Rebuild Kit, 22-Piece

CSK7402 ... 74-77 ... Kit without Mounting Tabs on Sway Bar with 1",
 1-1/16", 1-1/8" Sway Bar
 CSK7403 ... 76-77 ... Kit w/ Mounting Tabs on Sway Bar with 1-1/8",
 1-3/16" Sway Bar
 CSK7801 ... 78-88 ... Front Rebuild Kit, 24 Ps. with 1" & 1-1/16" Sway
 Bar without Tabs on Mounting Clamps
 CSK7802 ... 78-88 ... Front Rebuild Kit, 24 Ps. with 1-1/8" & 1-1/4"
 Sway Bar without Tabs on Mounting Clamps
 CSK7803 ... 78-88 ... Front Rebuild Kit, 24 Ps. with 1-5/16" & 1-7/16"
 Sway Bar without Tabs on Mounting Clamps

GTO/LEMANS FRONT BRAKE CONVERSIONS

**STREET
SERIES**

FRONT DISC BRAKE CONVERSION KITS

U.S.A. Made
TIMKEN Bearings

FRONT CONVERSIONS INCLUDE:

- 11" Rotors
- Forged Spindles (OE or 2" Drop)
- Timken Bearings
- New Calipers
- Caliper Brackets
- Organic Pads
- Backing Plates
- Flex Hoses & Clips
- Valve Bracket & Hardware
- Banjo Bolts & Copper Washers
- Dust Caps
- Castle Nuts & Pins
- Washers
- Grease Seals
- Spindle Gaskets
- Steering Arm Bolts
- Master Cylinder
- Combination Valve
- Pedal Rod Extension
- Brake Switch Pigtail

WORKS WITH FACTORY 14" & LARGER DISC BRAKE WHEELS

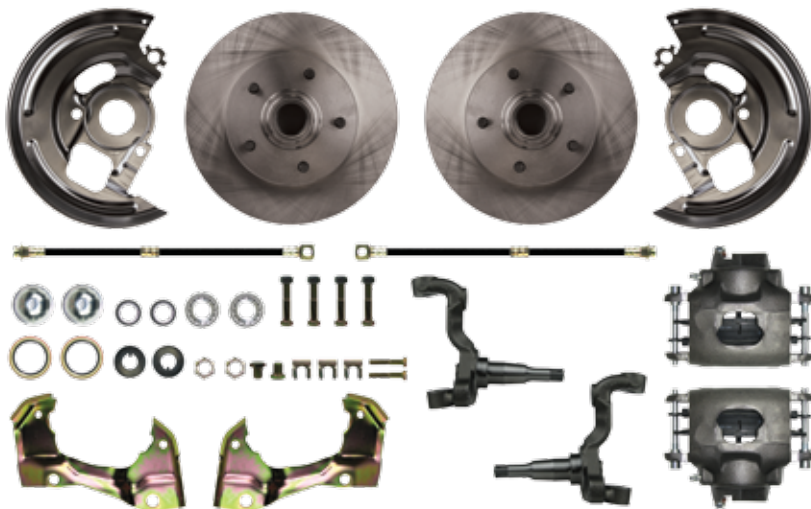

Right Stuff disc conversions are the most complete kits in the industry at the right price. High quality components, professional packaging, and after-sale support by "hands-on" technicians create an unbeatable value. Consider one of our complete brake line packages for a carefree installation.



Packages include At-the-Wheel Disc Conversion Kit & Master Cylinder with Valve (Manual) or Master Cylinder with Booster and Valve (Power).

POWER PACKAGE

MANUAL PACKAGE

9" or 11" inch booster, Call for other diameters

UPGRADES

The next page offers upgrades to fully customize your conversion kit.

AT-THE-WHEEL FRONT KITS From

STOCK HEIGHT FRONT KITS

- AFXWK01C64-72..... At-the-Wheel Disc Conversion Kit
- AFXSD01C.....64-72..... Manual Disc Conversion Package
- AFXDC01C64-72..... 9" Power Disc Conversion Package
- AFXDC06C67-72..... 11" Power Disc Conversion Package

2" DROP FRONT KITS

- AFXWK01D64-72..... At-the-Wheel Disc Conversion Kit
- AFXSD01D.....64-72..... Manual Disc Conversion Package
- AFXDC01D64-72..... 9" Power Disc Conversion Package
- AFXDC06D67-72..... 11" Power Disc Conversion Package

SUSPENSION KITS

**COMING
IN 2017**

Standard rubber kits meet O.E. specifications. Polyurethane kits provide better handling and a firmer ride. Poly kits include upgraded control arm bushings, sway bar bushings, and sway bar links. Pre-packaged kits offer huge savings over individual suspension parts. Most kits include the following:

- Lower Ball Joints (2)
- Upper Ball Joints (2)
- Lower Ctrl. Arm Bushings (4)
- Upper Ctrl. Arm Bushings (4)
- Inner Tie Rods (2) (Extra Value)
- Sway Bar Link Kits (2)
- Tie Rod Adj. Sleeves (2)
- Sway Bar Bushings (2)
- Outer Tie Rods (2)

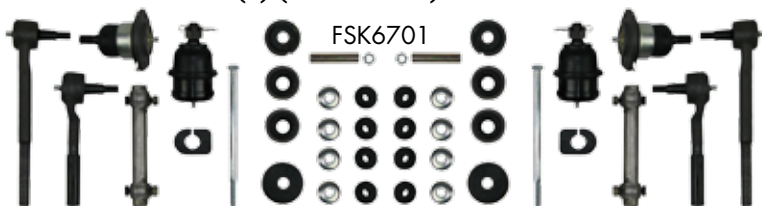

- FSK6701 67-69 ... Front Rebuild Kit, 22-Piece
- FSK6701U.. 67-69 ... Front Rebuild Kit, 22-Piece - (Poly)
- FSK7001 70-72 ... Front Rebuild Kit, 24-Piece
- FSK730173 Front Rebuild Kit, 24-Piece
- FSK740174 Front Rebuild Kit, 24-Piece
- FSK750175 Front Rebuild Kit, 24-Piece
- FSK7601 76-79 ... Front Rebuild Kit, 26-Piece with 15/16", 1-1/8", & 1-3/16" Sway Bar with Tabs on Mounting Clamps
- FSK7602 76-79 ... Front Rebuild Kit, 24-Piece with 1" & 1 1/16" Sway Bar without Tabs on Mounting Clamps
- FSK7603 76-79 ... Front Rebuild Kit, 24-Piece with 1-1/8" & 1-3/16" Sway Bar without Tabs on Mounting Clamps
- FSK7604 76-79 ... Front Rebuild Kit, 26-Piece with 1-1/4", 1-5/16", & 1-7/16" Sway Bar without Tabs on Mounting Clamps

FRONT DISC BRAKE CONVERSION UPGRADES

STREET SERIES

SHOW'N GO UPGRADE TRIM KITS

These At-the-Wheel Disc Conversion Kits (stock height or 2" drop) include upgraded drilled slotted rotors with zinc plating, powder coated calipers in red or black, and braided stainless hoses.



STOCK HEIGHT SHOW'N GO

AFXWK01CS 64-72 ... At-the-Wheel Disc Conversion Kit - Black
 AFXWK01CZ 64-72 ... At-the-Wheel Disc Conversion Kit - Red
 AFXSD01CS..... 64-72 ... Manual Disc Conversion Package - Black
 AFXSD01CZ..... 64-72 ... Manual Disc Conversion Package - Red
 AFXDC01CS 64-72 ... Power Disc Conversion Package - Black
 AFXDC01CZ 64-72 ... Power Disc Conversion Package - Red

2" DROP SHOW'N GO

AFXWK01DS 64-72 ... At-the-Wheel Disc Conversion Kit - Black
 AFXWK01DZ 64-72 ... At-the-Wheel Disc Conversion Kit - Red
 AFXSD01DS..... 64-72 ... 2" Drop Manual Disc Conv Pkg - Black
 AFXSD01DZ..... 64-72 ... 2" Drop Manual Disc Conv Pkg - Red
 AFXDC01DS 64-72 ... 2" Drop Power Disc Conv Pkg - Black
 AFXDC01DZ 64-72 ... 2" Drop Power Disc Conv Pkg - Red

SHOW STOPPER TRIM PACKAGES

Includes At-the-Wheel Front Disc Conversion Kit (stock height or 2" drop) with natural finish calipers. The Manual Packages get an upgraded chrome plated master cylinder and combination valve with bracket. Power Packages include an upgraded 8" dual chrome booster.

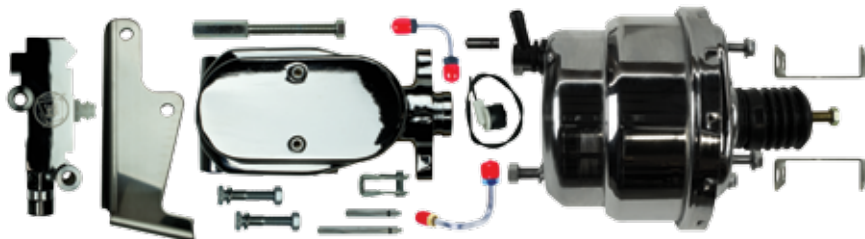

STOCK HEIGHT SHOW STOPPER

AFXSD01CX.....64-72.... Manual Disc Conversion Package
 AFXDC01CX 64-72 ... Power Disc Conversion Package

2" DROP SHOW STOPPER

AFXSD01DX.....64-72.... Manual Disc Conversion Package
 AFXDC01DX64-72.... Power Disc Conversion Package

BEST OF SHOW TRIM PACKAGES

Includes At-the-Wheel Front Disc Conversion Kit (stock height or 2" drop) with black or red calipers, drilled & slotted rotors & braided stainless hoses. The Manual Packages get an upgraded chrome plated master cylinder and combination valve with bracket. Power Packages include an upgraded 8" dual chrome booster.



STOCK HEIGHT BEST OF SHOW

AFXSD01CSX....64-72... Manual Disc Conversion Package - Black
 AFXSD01CZX....64-72... Manual Disc Conversion Package - Red
 AFXDC01CSX ...64-72... 8" Power Disc Conversion Package - Black
 AFXDC01CZX ...64-72... 8" Power Disc Conversion Package - Red

2" DROP BEST OF SHOW

AFXSD01DSX....64-72... Manual Disc Conversion Package - Black
 AFXSD01DZX....64-72... Manual Disc Conversion Package - Red
 AFXDC01DSX....64-72... 8" Power Disc Conversion Package - Black
 AFXDC01DZX ...64-72... 8" Power Disc Conversion Package - Red



Disc Brake Conversions require special brake lines that fit your new disc conversion setup. Right Stuff offers "No Brainer" Brake Line Kits that include all components needed from your master cylinder back to your rear wheel cylinder or calipers. They include front brake line kit, front to rear line, rear axle lines & flex hose, & clip set.

See page 174 for your application

GTO/LEMANS 4-WHEEL BRAKE CONVERSIONS

**STREET
SERIES**

FOUR WHEEL DISC BRAKE CONVERSION KITS

U.S.A. Made
TIMKEN Bearings

FRONT CONVERSIONS INCLUDE:

- 11" Rotors
- Forged Spindles (OE or 2" Drop)
- Timken Bearings
- New Calipers
- Caliper Brackets
- Organic Pads
- Backing Plates
- Flex Hoses & Clips
- Valve Bracket & Hardware
- Banjo Bolts & Copper Washers
- Dust Caps
- Castle Nuts & Pins
- Washers
- Grease Seals
- Spindle Gaskets
- Steering Arm Bolts
- Master Cylinder
- Combination Valve
- Pedal Rod Extension
- Brake Switch Pigtail

REAR CONVERSIONS INCLUDE:

- 11" Rotors
- Caliper Brackets & Spacers
- Weld-On Hose Brackets
- Flex Hoses
- Backing Plates (Exclusive), not for AFXRD78 or AFXRDM78
- New Loaded Caliper
- E-Brake Cables
- Hardware

Right Stuff disc conversions are the most complete kits in the industry at the right price. High quality components, professional packaging, and after-sale support by "hands-on" technicians create an unbeatable value. Consider one of our complete brake line packages for a carefree installation. See page 169 to verify axle flange measurements for these kits.



Packages include At-the-Wheel Disc Conversion Kits & Master Cylinder with Valve (Manual) or Master Cylinder with Booster and Valve (Power).

WORKS WITH 15" AND LARGER WHEELS

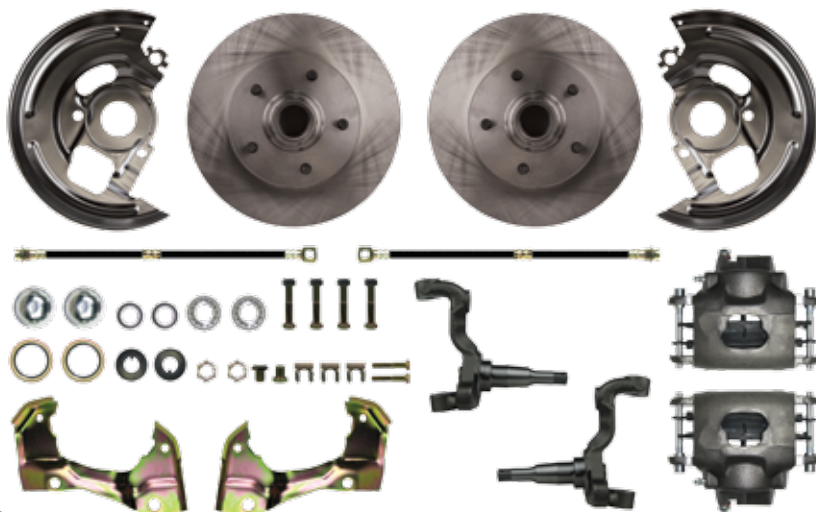

AT-THE-WHEEL FRONT KIT

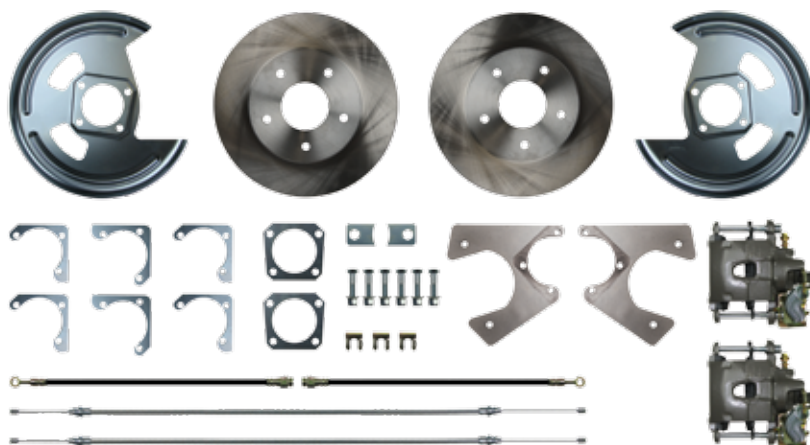

AT-THE-WHEEL REAR KIT

6-3/16" INSIDE ROTOR DIAMETER - 2.78" CENTER HOLE

STOCK HEIGHT 4-WHEEL KITS

- AFXSD41C..... 64-72 Manual Disc Brake Conversion Package
- AFXDC41C 64-72 9" Power Disc Brake Conversion Package
- AFXDC46C 67-72 11" Power Disc Brake Conversion Package

2" DROP 4-WHEEL KITS

- AFXSD41D..... 64-72 Manual Disc Brake Conversion Package
- AFXDC41D 64-72 9" Power Disc Brake Conversion Package
- AFXDC46D 67-72 11" Power Disc Brake Conversion Package



UPGRADES The next page offers upgrades to fully customize your conversion kit.

GTO/LEMANS 4-WHEEL BRAKE UPGRADES

4-WHEEL DISC BRAKE CONVERSION UPGRADES

STREET SERIES

SHOW'N GO UPGRADE TRIM KITS

These At-the-Wheel Disc Conversion Kits (stock height or 2" drop) include upgraded drilled slotted rotors with zinc plating, powder coated calipers in red or black, and braided stainless hoses.



STOCK HEIGHT SHOW'N GO

AFXSD41CS...64-72... Manual Disc Brake Conv Package - Black
AFXSD41CZ...64-72... Manual Disc Brake Conv Package - Red
AFXDC41CS...64-72... Power Disc Brake Conv Package - Black
AFXDC41CZ...64-72... Power Disc Brake Conv Package - Red

2" DROP SHOW'N GO

AFXSD41DS...64-72... 2" Drop Manual Disc Brake Conv Pkg - Black
AFXSD41DZ...64-72... 2" Drop Manual Disc Brake Conv Pkg - Red
AFXDC41DS...64-72... 2" Drop Power Disc Brake Conv Pkg - Black
AFXDC41DZ...64-72... 2" Drop Power Disc Brake Conv Pkg - Red

SHOW STOPPER TRIM PACKAGES

Includes At-the-Wheel Front Disc Conversion Kit (stock height or 2" drop) with natural finish calipers. The Manual Packages get an upgraded chrome plated master cylinder and combination valve with bracket. Power Packages include an upgraded 8" dual chrome booster.

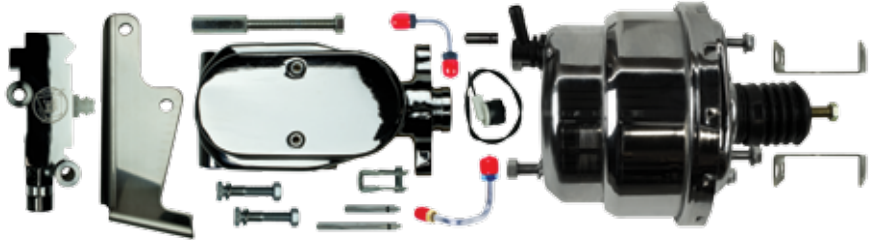

STOCK HEIGHT SHOW STOPPER

AFXSD41CX...64-72... Manual Disc Brake Conversion Package
AFXDC41CX...64-72... 8" Power Disc Brake Conversion Package

2" DROP SHOW STOPPER

AFXSD41DX...64-72... Manual Disc Brake Conversion Package
AFXDC41DX...64-72... 8" Power Disc Brake Conversion Package

BEST OF SHOW TRIM PACKAGES

Includes At-the-Wheel Front Disc Conversion Kit (stock height or 2" drop) with black or red calipers, drilled & slotted rotors & braided stainless hoses. The Manual Packages get an upgraded chrome plated master cylinder and combination valve with bracket. Power Packages include an upgraded 8" dual chrome booster.



STOCK HEIGHT BEST OF SHOW

AFXSD41CSX...64-72... Manual Disc Brake Conversion Pkg - Black
AFXSD41CZX...64-72... Manual Disc Brake Conversion Pkg - Red
AFXDC41CSX...64-72... 8" Power Disc Brake Conversion Pkg - Black
AFXDC41CZX...64-72... 8" Power Disc Brake Conversion Pkg - Red

2" DROP BEST OF SHOW

AFXSD41DSX...64-72... Manual Disc Brake Conversion Pkg - Black
AFXSD41DZX...64-72... Manual Disc Brake Conversion Pkg - Red
AFXDC41DSX...64-72... 8" Power Disc Brake Conversion Pkg - Black
AFXDC41DZX...64-72... 8" Power Disc Brake Conversion Pkg - Red



Disc Brake Conversions require special brake lines that fit your new disc conversion setup. Right Stuff offers "No Brainer" Brake Line Kits that include all components needed from your master cylinder back to your rear wheel cylinder or calipers. They include front brake line kit, front to rear line, rear axle lines & flex hose, & clip set.

See page 174 for your application

STREET SERIES

REAR DISC BRAKE CONVERSION KITS

REAR CONVERSIONS INCLUDE:

- 11" Rotors
- Caliper Brackets & Spacers
- Weld-On Hose Brackets
- Flex Hoses
- Backing Plates (Exclusive), not for AFXRD78 or AFXRDM78
- New Loaded Caliper
- E-Brake Cables
- Hardware

Right Stuff disc conversions are the most complete kits in the industry at the right price. High quality components, professional packaging, and after-sale support by "hands-on" technicians create an unbeatable value. Consider one of our complete brake line packages for a carefree installation. See the next page to verify axle flange measurements for these kits.

NOTE:
 FITS FACTORY REAR ENDS
 CALL FOR CUSTOM APPLICATIONS

WORKS WITH 15" AND LARGER WHEELS

6-3/16" INSIDE ROTOR DIAMETER - 2.78" CENTER HOLE

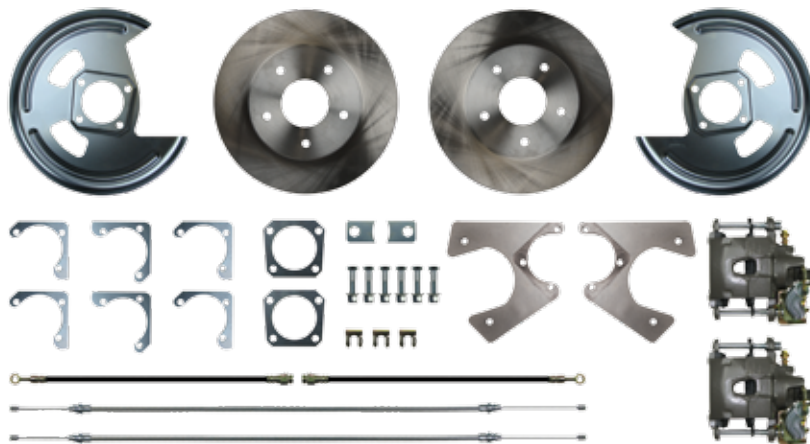

ATTENTION Before you order, be sure to measure the axle flange on your vehicle.

REAR KITS WITH E-BRAKE

- AFXRD01 64-77 10 & 12 Bolt
- AFXRD78 78-81 10 Bolt

REAR KITS WITHOUT E-BRAKE

- AFXRDM1 64-77 10 & 12 Bolt
- AFXRDM78 78-81 10 Bolt

REAR DISC BRAKE CONVERSION UPGRADES

STREET SERIES

SHOW'N GO UPGRADE TRIM PACKAGES

These Rear Disc Conversion Kits include upgraded drilled slotted rotors with zinc plating, powder coated calipers in red or black, and braided stainless hoses.



REAR UPGRADE WITH E-BRAKE

- AFXRD01S 64-77 10 & 12 Bolt - Black
- AFXRD01Z 64-77 10 & 12 Bolt - Red
- AFXRD78S 78-81 10 Bolt - Black
- AFXRD78Z 78-81 10 Bolt - Red

REAR UPGRADE W/O E-BRAKE

- AFXRDM1S 64-77 ... 10 & 12 Bolt - Black
- AFXRDM1Z 64-77 ... 10 & 12 Bolt - Red
- AFXRDM78S ... 78-81 ... 10 Bolt - Black
- AFXRDM78Z ... 78-81 ... 10 Bolt - Red



TECH QUESTION?

STREET SERIES

REAR +2 DISC BRAKE CONVERSION KITS

REAR +2 CONVERSIONS INCLUDE:

- 11" Drilled-Slotted-Zinc Rear Rotors
- Black or Red Rear Powder Coated Calipers
- Braided Stainless Rear Hoses
- Brackets, Spacers, Hardware
- Weld-On Hose Brackets
- Backing Plates *TRSD Exclusive
- E-Brake Cables

+2 KITS ALSO INCLUDE

- Drilled-Slotted-Zinc Front Rotors
- Black or Red Powder Coated Front Calipers
- Braided Stainless Front Hoses

Right Stuff disc conversions are the most complete kits in the industry at the right price. High quality components, professional packaging, & after-sale support by "hands-on" technicians create an unbeatable value. Get a rear conversion & matching front upgrades with a single part number.



FRONT ROTORS
DRILLED & SLOTTED

NOTE:
FITS FACTORY
REAR ENDS
CALL FOR CUSTOM
APPLICATIONS

WORKS WITH 15" AND LARGER WHEELS

REAR DISC BRAKES + MATCHING FRONT UPGRADES
6-3/16" INSIDE ROTOR DIAMETER - 2.78" CENTER HOLE

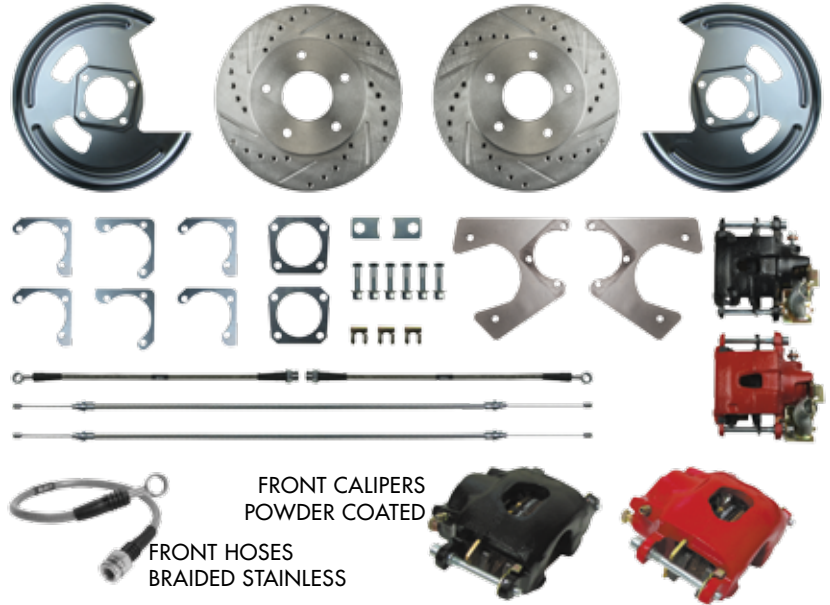

FRONT CALIPERS
POWDER COATED

FRONT HOSES
BRAIDED STAINLESS

REAR +2 KITS WITH E-BRAKE

- A69RD01S 69-72 Black Calipers, Drilled/Slotted
- A69RD01Z 69-72 Red Calipers, Drilled/Slotted
- A73RD01S 73-77 Black Calipers, Drilled/Slotted
- A73RD01Z 73-77 Red Calipers, Drilled/Slotted
- A78RD78S 78 Black Calipers, Drilled/Slotted
- A78RD78Z 78 Red Calipers, Drilled/Slotted
- A79RD78S 79-81 Black Calipers, Drilled/Slotted
- A79RD78Z 79-81 Red Calipers, Drilled/Slotted

REAR +2 KITS WITHOUT E-BRAKE

- A69RDM1S..... 69-72 Black Calipers, Drilled/Slotted
- A69RDM1Z 69-72 Red Calipers, Drilled/Slotted
- A73RDM1S..... 73-77 Black Calipers, Drilled/Slotted
- A73RDM1Z 73-77 Red Calipers, Drilled/Slotted
- A78RDM78S..... 78 Black Calipers, Drilled/Slotted
- A78RDM78Z 78 Red Calipers, Drilled/Slotted
- A79RDM78S..... 79-81 Black Calipers, Drilled/Slotted
- A79RDM78Z 79-81 Red Calipers, Drilled/Slotted

AXLE FLANGE DIAGRAMS

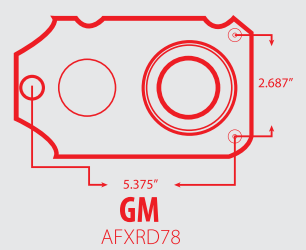
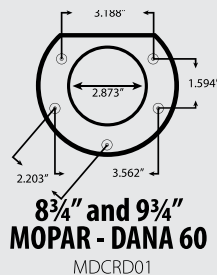
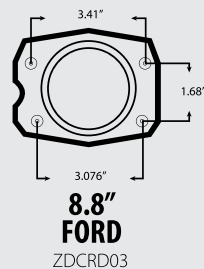
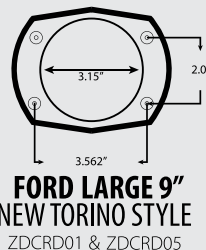
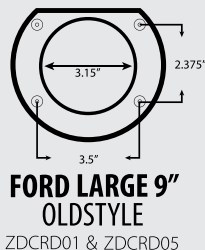
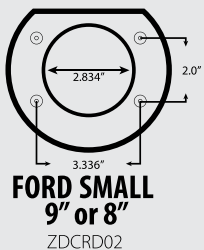
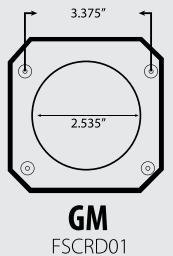
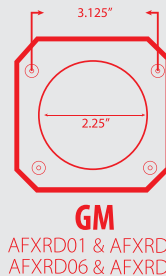
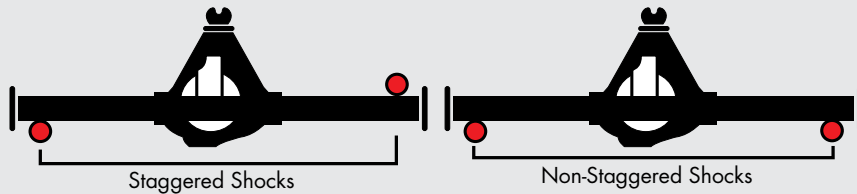

GTO/LEMANS EZ FIT CONVERSION KITS



BRAKE•KITS

Fits stock 14" wheel. Bolts to stock drum or disc brake spindles. Minimal offset for better fenderwell clearance. Proprietary rotor.

EZ FIT BRAKE CONVERSION KITS

HALF THE INSTALL TIME
KEEP YOUR FACTORY
14" WHEELS

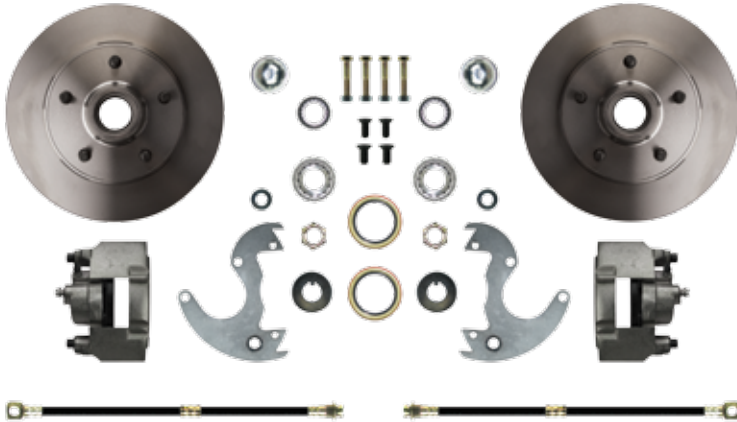

FRONT AT-THE WHEEL KITS

Bolts to your stock drum or disc brake spindles.

Available with standard stock-style rotors or upgraded drilled, slotted & zinc rotors.

FRONT 14" - STANDARD ROTORS

AFXWK14 ...64-72.....Front At-the-Wheel Disc Conversion Kit
 AFXSD14.....64-72.....Front Manual Disc Conversion Package
 AFXDC1464-72.....Front Power Disc Conversion Package

FRONT 14" - UPGRADE ROTORS

AFXWK14A ...64-72.... Front At-the-Wheel Disc Conversion Kit
 AFXSD14A.....64-72.... Front Manual Disc Conversion Package
 AFXDC14A64-72.... Front Power Disc Conversion Package

REAR 14" - STANDARD ROTORS

AFXRD1464-77.... Rear Kit, Non-Staggered

REAR 14" - UPGRADE ROTORS

AFXRD14A.....64-77.... Rear Kit, Non-Staggered



LOOKING FOR A DIFFERENT BOOSTER + MASTER CYLINDER IN YOUR KIT?

Simply purchase an At-The-Wheel Kit above along with any Booster + Master combo on page 159.



EZ FIT FRONT CONVERSIONS INCLUDE:

- 10" Rotors with Organic Pads
- New Calipers & Brackets
- Banjo Bolts & Copper Washers
- Dust Caps, Castle Nuts & Pins
- Brake Switch Pigtail
- Master Cylinder (Power/Manual Kits)
- Timken Bearings
- Flex Hoses & Kit
- Grease Seals
- Steering Arm Bolts
- Combination Valve
- 9" Booster (Power)

EZ FIT REAR CONVERSIONS INCLUDE:

- Fits 14" wheels
- Uses proprietary rotor
- Built in e-brake (No cables included)



Packages include At-the-Wheel Disc Conversion Kits & Master Cylinder with Valve (Manual) or Master Cylinder with Booster and Valve (Power).

POWER PACKAGE



MANUAL PACKAGE



Disc Brake Conversions require special brake lines that fit your new disc conversion setup. Right Stuff offers "No Brainer" Brake Line Kits that include all components needed from your master cylinder back to your rear wheel cylinder or calipers. They include front brake line kit, front to rear line, rear axle lines & flex hose, & clip set.

See page 174 for your application



COMPLETE DISC BRAKE CONVERSION KITS



U.S.A. Made
TIMKEN Bearings

Right Stuff Performance Series disc conversions are the most complete kits in the industry at the right price. Designed for the performance street machine with high quality components, professional packaging, and after-sale support by "hands-on" technicians and many DIY videos at rightstuff create an unbeatable value.

Kits are available as a **Disc Brake Upgrade** that bolts to stock front disc brake spindles, or as an **At-The-Wheel Kit** that includes everything for a front disc brake conversion, and as a **Complete Conversion Kit** which includes everything in the At-The-Wheel Kit with the addition of the master cylinder, booster and prop valve (Power or Manual).

AT-THE-WHEEL CONVERSION KITS INCLUDE:

- 11" Drilled & Slotted Rotors
- Wilwood Dual Piston Calipers
- Caliper Brackets
- Backing Plates
- Timken Bearings
- Castle Nuts & Pins
- Dust Caps
- Spindles
- Organic Pads
- Washers
- Grease Seals
- Spindle Gaskets
- Steering Arm Bolts
- Hardware

COMPLETE CONVERSION KITS ALSO INCLUDE

- Master Cylinder - Chrome or Standard Finish
- Flex Hoses & Clips
- Valve Bracket & Hardware
- Banjo Bolts & Copper Washers
- Combination Valve
- Brake Switch Pigtail
- Pedal Rod Extension

WORKS WITH 15" AND LARGER WHEELS

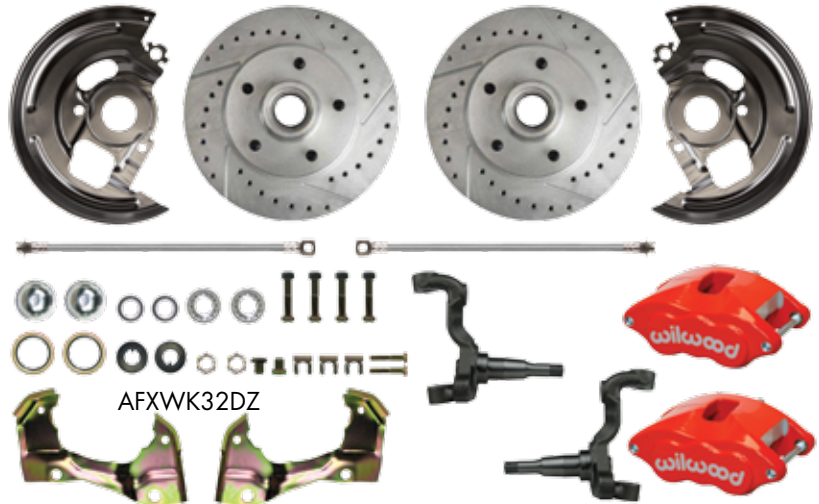

FRONT AT-THE-WHEEL KITS From



STANDARD PACKAGE

CHROME PACKAGE

Packages include At-the-Wheel Disc Conversion Kits and Chrome or Standard Finish Master Cylinder with Booster and Valve (Power).



DISC BRAKE UPGRADE KITS INCLUDE (Kit is Designed to Bolt to Stock Disc Brake Spindles)

- Wilwood 2-Piston Aluminum Calipers
- Cross-Drilled & Slotted Zinc Plated Rotors
- Braided Stainless Hoses
- Organic Brake Pads

DISC BRAKE UPGRADE KITS

RCP69S 64-72 Black 2-Piston Wilwood Calipers
RCP69Z 64-72 Red 2-Piston Wilwood Calipers

AT-THE-WHEEL FRONT DISC KITS

AFXWK32S..... 64-72... At-the-Wheel Stock Height - Black Wilwood
AFXWK32Z 64-72... At-the-Wheel Stock Height - Red Wilwood
AFXWK32DS ... 64-72... At-the-Wheel 2" Drop - Black Wilwood
AFXWK32DZ ... 64-72... At-the-Wheel 2" Drop - Red Wilwood

STOCK HEIGHT FRONT KITS

AFXDC32S..... 64-72... Standard Booster/Master - Black Wilwood
AFXDC32Z 64-72... Standard Booster/Master - Red Wilwood
AFXDC32SX..... 64-72... Chrome Booster/Master - Black Wilwood
AFXDC32ZX..... 64-72... Chrome Booster/Master - Red Wilwood

2" DROP FRONT KITS

AFXDC32DS 64-72... Standard Booster/Master - Black Wilwood
AFXDC32DZ 64-72... Standard Booster/Master - Red Wilwood
AFXDC32DSX... 64-72... Chrome Booster/Master - Black Wilwood
AFXDC32DZX .. 64-72... Chrome Booster/Master - Red Wilwood



DISC BRAKE CONVERSION KITS



DESIGNED FOR 17\"/>

Bold looks define the Signature Series line of brake kits. Large diameter zinc plated rotors, powder coated calipers, fully machined caliper brackets, & braided stainless brake hoses. Only premium quality components make the grade. We back every kit with industry leading technical support. Signature Series kits are amazing brakes at a great price. Add a "No Brainer" Brake Line Kit for a true bolt-on install.

SIGNATURE SERIES FRONT KIT

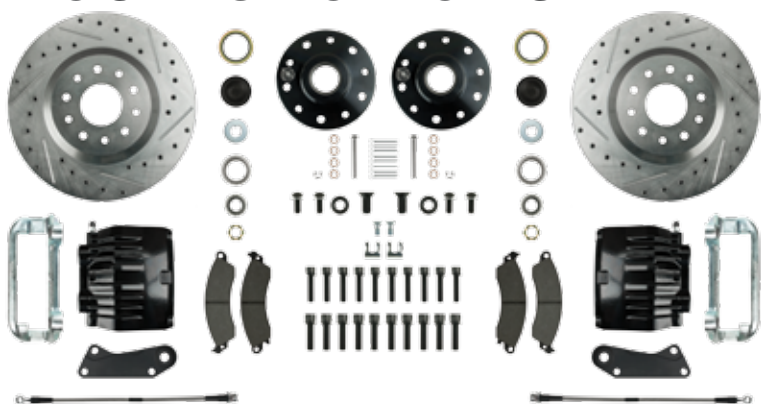

U.S.A. Made **TIMKEN** Bearings



STOCK HEIGHT FRONT KITS

Uses Existing Drum or Disc Brake Spindles

- AFXWK31CS 64-72..... At-the-Wheel Kit - Black Calipers
- AFXWK31CZ 64-72..... At-the-Wheel Kit - Red Calipers
- AFXSD31CS 64-72..... Manual Kit - Black Calipers
- AFXSD31CZ 64-72..... Manual Kit - Red Calipers
- AFXDC31CS 64-72..... Power Kit - Black Calipers
- AFXDC31CZ 64-72..... Power Kit - Red Calipers

STOCK HEIGHT 4-WHEEL KITS

Stock Height - Non-Staggered Shocks

- AFXWK51CS 64-72..... At-the-Wheel Kit - Black Calipers
- AFXWK51CZ 64-72..... At-the-Wheel Kit - Red Calipers
- AFXSD51CS 64-72..... Manual Kit - Black Calipers
- AFXSD51CZ 64-72..... Manual Kit - Red Calipers
- AFXDC51CS 64-72..... Power Kit - Black Calipers
- AFXDC51CZ 64-72..... Power Kit - Red Calipers

2" DROP FRONT KITS

Includes New 2" Drop Spindles

- AFXWK31DS 64-72..... At-the-Wheel Kit - Black Calipers
- AFXWK31DZ 64-72..... At-the-Wheel Kit - Red Calipers
- AFXSD31DS 64-72..... Manual Kit - Black Calipers
- AFXSD31DZ 64-72..... Manual Kit - Red Calipers
- AFXDC31DS 64-72..... Power Kit - Black Calipers
- AFXDC31DZ 64-72..... Power Kit - Red Calipers

2" DROP 4-WHEEL KITS

2" Drop - Non-Staggered Shocks

- AFXWK51DS 64-72..... At-the-Wheel Kit - Black Calipers
- AFXWK51DZ 64-72..... At-the-Wheel Kit - Red Calipers
- AFXSD51DS 64-72..... Manual Kit - Black Calipers
- AFXSD51DZ 64-72..... Manual Kit - Red Calipers
- AFXDC51DS 64-72..... Power Kit - Black Calipers
- AFXDC51DZ 64-72..... Power Kit - Red Calipers



Disc Brake Conversions require special brake lines that fit your new disc conversion setup. Right Stuff offers "No Brainer" Brake Line Kits that include all components needed from your master cylinder back to your rear wheel cylinder or calipers. They include front brake line kit, front to rear line, rear axle lines & flex hose, & clip set.

See page 174 for your application

X-TRIM DISC BRAKE CONVERSION UPGRADES



Start turning heads with a show finished upper assembly. Manual kits get a chrome plated master cylinder and combination valve with bracket. Power kits also include an 8" dual chrome booster.



X-TRIM UPGRADE FRONT KITS

Stock Height uses Existing Spindles

- AFXSD31CSX.... 64-72 ... Manual Kit - Black Calipers - Stock Height
- AFXSD31CZX.... 64-72 ... Manual Kit - Red Calipers - Stock Height
- AFXDC31CSX ... 64-72 ... Power Kit - Black Calipers - Stock Height
- AFXDC31CZX ... 64-72 ... Power Kit - Red Calipers - Stock Height

2" Drop Includes New Spindles

- AFXSD31DSX..... 64-72.....Manual Kit - Black Calipers - 2" Drop
- AFXSD31DZX..... 64-72.....Manual Kit - Red Calipers - 2" Drop
- AFXDC31DSX..... 64-72.....Power Kit - Black Calipers - 2" Drop
- AFXDC31DZX 64-72.....Power Kit - Red Calipers - 2" Drop

X-TRIM UPGRADE 4-WHEEL KITS

Non-Staggered Shocks

- AFXSD51CSX... 64-72... Manual Kit - Black Calipers - Stock Height
- AFXSD51CZX... 64-72... Manual Kit - Red Calipers - Stock Height
- AFXDC51CSX .. 64-72... Power Kit - Black Calipers - Stock Height
- AFXDC51CZX .. 64-72... Power Kit - Red Calipers - Stock Height

- AFXSD51DSX... 64-72... Manual Kit - Black Calipers - 2" Drop
- AFXSD51DZX... 64-72... Manual Kit - Red Calipers - 2" Drop
- AFXDC51DSX... 64-72... Power Kit - Black Calipers - 2" Drop
- AFXDC51DZX .. 64-72... Power Kit - Red Calipers - 2" Drop



REAR DISC BRAKE CONVERSION KITS

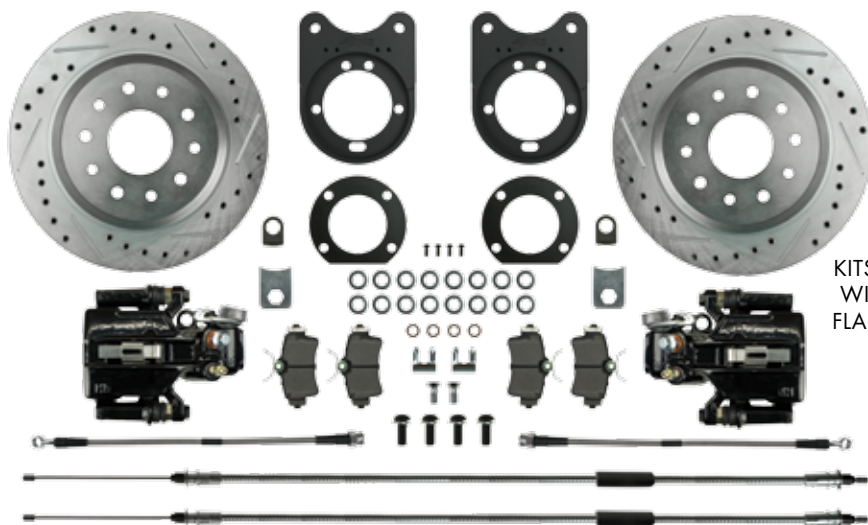

KITS FIT AXLES WITH 3-1/8" FLANGE ONLY

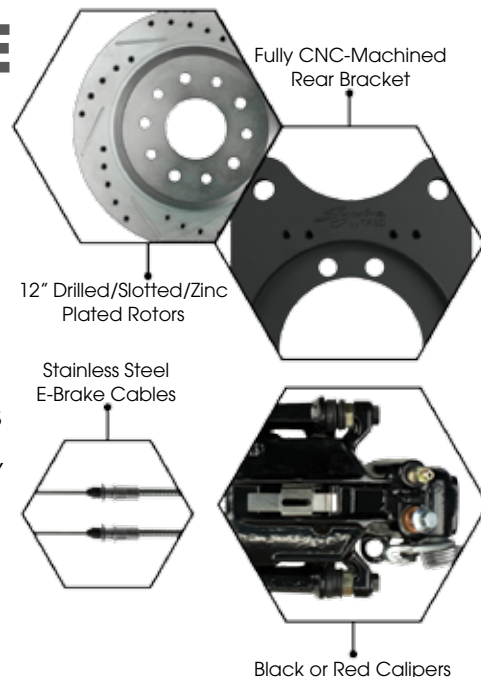

REAR DISC CONVERSION KITS

AFXRD31S 64-77 Rear Disc Conversion - Black

AFXRD31Z 64-77 Rear Disc Conversion - Red





No Brainer BRAKE LINE KITS FOR DISC CONVERSIONS

When you add disc brakes to your car you are using a new valve that has different size ports pointing in different directions. Even if your lines are brand new or great originals, you are going to have issues trying to use them. Our "No Brainer" Brake Line Kit fixes all these issues from your master cylinder all the way back to your rear wheel cylinders or rear calipers. We give you all the lines to complete the installation. We also include the rear flex hose and a full clip set to install your lines. Extremely discounted prices and great instructions make this kit a No Brainer.

SIMPLIFY YOUR DISC BRAKE CONVERSION INSTALLATION WITH ALL OF THE BRAKE LINES YOU WILL NEED.

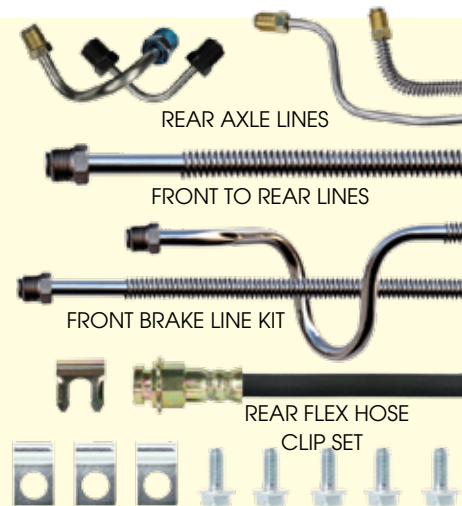

MANUAL - NO VACUUM BOOSTER

FRONT DISC/REAR DRUM LINES

AOM64H2 64-65 OE Steel, Hardtop
 ASM64H2 64-65 Stainless, Hardtop
 AOM64C2 64-65 OE Steel, Convertible
 ASM64C2 64-65 Stainless, Convertible
 AOM66H2 66 OE Steel, Hardtop
 ASM66H2 66 Stainless, Hardtop
 AOM66C2 66 OE Steel, Convertible
 ASM66C2 66 Stainless, Convertible
 AOM67H2 67 OE Steel, Hardtop
 ASM67H2 67 Stainless, Hardtop
 AOM67C2 67 OE Steel, Convertible
 ASM67C2 67 Stainless, Convertible
 AOM68H2 68 OE Steel, Hardtop
 ASM68H2 68 Stainless, Hardtop
 AOM68C2 68 OE Steel, Convertible
 ASM68C2 68 Stainless, Convertible
 AOM69H2 69-72 OE Steel, Hardtop
 ASM69H2 69-72 Stainless, Hardtop
 AOM69C2 69-72 OE Steel, Convertible
 ASM69C2 69-72 Stainless, Convertible

POWER - WITH VACUUM BOOSTER

FRONT DISC/REAR DRUM LINES

AOP64H2..... 64-65 OE Steel, Hardtop
 ASP64H2..... 64-65 Stainless, Hardtop
 AOP64C2..... 64-65 OE Steel, Convertible
 ASP64C2 64-65 Stainless, Convertible
 AOP66H2..... 66 OE Steel, Hardtop
 ASP66H2..... 66 Stainless, Hardtop
 AOP66C2..... 66 OE Steel, Convertible
 ASP66C2 66 Stainless, Convertible
 AOP67H2..... 67 OE Steel, Hardtop
 ASP67H2..... 67 Stainless, Hardtop
 AOP67C2..... 67 OE Steel, Convertible
 ASP67C2 67 Stainless, Convertible
 AOP68H2..... 68 OE Steel, Hardtop
 ASP68H2..... 68 Stainless, Hardtop
 AOP68C2..... 68 OE Steel, Convertible
 ASP68C2 68 Stainless, Convertible
 AOP69H2..... 69-72 OE Steel, Hardtop
 ASP69H2..... 69-72 Stainless, Hardtop
 AOP69C2..... 69-72 OE Steel, Convertible
 ASP69C2 69-72 Stainless, Convertible

4-WHEEL DISC LINES

AOM64H4 64-65 OE Steel, Hardtop
 ASM64H4 64-65 Stainless, Hardtop
 AOM64C4 64-65 OE Steel, Convertible
 ASM64C4 64-65 Stainless, Convertible
 AOM66H4 66 OE Steel, Hardtop
 ASM66H4 66 Stainless, Hardtop
 AOM66C4 66 OE Steel, Convertible
 ASM66C4 66 Stainless, Convertible
 AOM67H4 67 OE Steel, Hardtop
 ASM67H4 67 Stainless, Hardtop
 AOM67C4 67 OE Steel, Hardtop
 ASM67C4 67 Stainless, Convertible
 AOM68H4 68 OE Steel, Hardtop
 ASM68H4 68 Stainless, Hardtop
 AOM68C4 68 OE Steel, Convertible
 ASM68C4 68 Stainless, Convertible
 AOM69H4 69-72 OE Street, Hardtop
 ASM69H4 69-72 Stainless, Hardtop
 AOM69C4 69-72 OE Steel, Convertible
 ASM69C4 69-72 Stainless, Convertible

4-WHEEL DISC LINES

AOP64H4..... 64-65 OE Steel, Hardtop
 ASP64H4..... 64-65 Stainless, Hardtop
 AOP64C4..... 64-65 OE Steel, Convertible
 ASP64C4 64-65 Stainless, Convertible
 AOP66H4..... 66 OE Steel, Hardtop
 ASP66H4..... 66 Stainless, Hardtop
 AOP66C4..... 66 OE Steel, Convertible
 ASP66C4 66 Stainless, Convertible
 AOP67H4..... 67 OE Steel, Hardtop
 ASP67H4..... 67 Stainless, Hardtop
 AOP67C4..... 67 OE Steel, Convertible
 ASP67C4 67 Stainless, Convertible
 AOP68H4..... 68 OE Steel, Hardtop
 ASP68H4..... 68 Stainless, Hardtop
 AOP68C4..... 68 OE Steel, Convertible
 ASP68C4 68 Stainless, Convertible
 AOP69H4..... 69-72 OE Steel, Hardtop
 ASP69H4..... 69-72 Stainless, Hardtop
 AOP69C4..... 69-72 OE Steel, Convertible
 ASP69C4 69-72 Stainless, Convertible

FRONT BRAKE LINE KITS

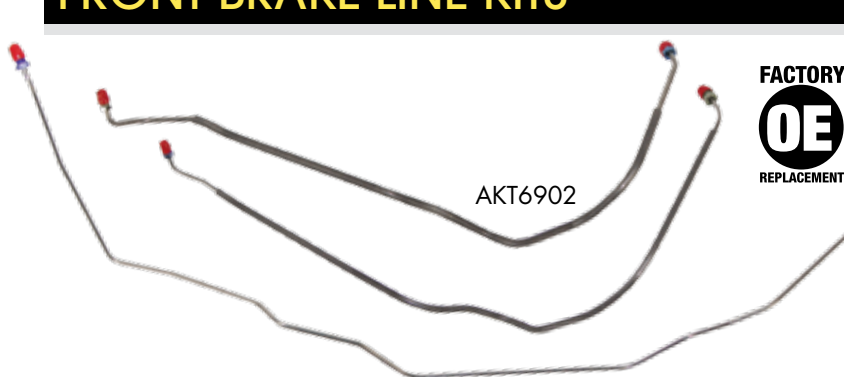

Front brake line kits consist of all brake lines under the hood. This includes the master cylinder to the distribution, combination or metering valve. The left and right front lines that run to the front flex hoses are also included. Call for individual component pricing. These line kits are for vehicles with factory brake systems.

ADD "S" TO PART NUMBER FOR STAINLESS STEEL

AKT6403...64-66... Standard Drum.....	3 Pcs.
AKT6404...64-66... Power Drum.....	3 Pcs.
AKT6715..... 67 Standard Drum.....	4 Pcs.
AKT6716..... 67 Power Drum.....	4 Pcs.
AKT6717..... 67 Power Disc	5 Pcs.
AKT6903...68-69... Power Disc	5 Pcs.

AKT6901 ...68-72... Standard Drum.....	6 Pcs.
AKT6902...68-72... Power Drum.....	6 Pcs.
AKT7003..... 70 Power Disc	5 Pcs.
AKT7103...71-72... Power Disc	4 Pcs.
AKT8603..... 81 Power Disc, Grand National....	4 Pcs.
AKT8201..... 82 Power Disc, Grand National....	4 Pcs.
AKT8603...83-87... Power Disc, Grand National....	4 Pcs.
QKT8601..... 86 Skyhawk	5 Pcs.

FRONT TO REAR BRAKE LINES

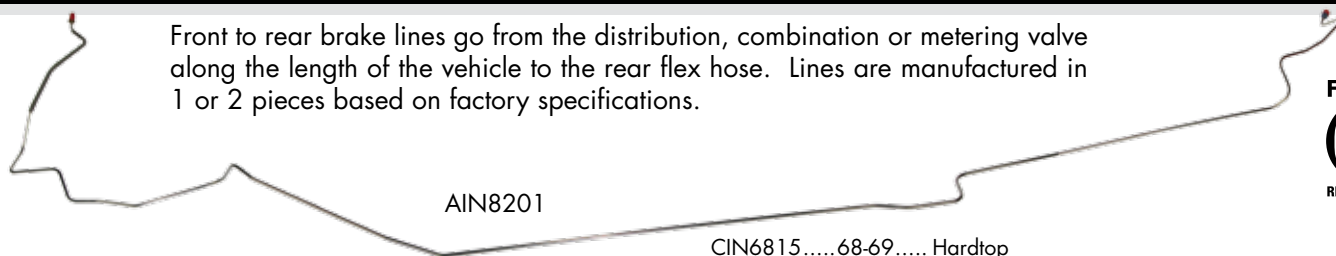

Front to rear brake lines go from the distribution, combination or metering valve along the length of the vehicle to the rear flex hose. Lines are manufactured in 1 or 2 pieces based on factory specifications.

ADD "S" TO PART NUMBER FOR STAINLESS STEEL

AIN6201.....62-63..... Hardtop
CIN6402.....64-66..... Convertible, 3/16"
CIN6503.....64-66..... Hardtop, 3/16"
CIN6402.....65-66..... GS Hardtop
CIN6605..... 66 Hardtop
CIN6606..... 66 Convertible
AIN6701..... 67 Hardtop
AIN6702..... 67 Convertible
AIN6702..... 67 GS Hardtop, with BB

CIN6815.....68-69..... Hardtop
CIN6816.....68-69..... Convertible
CIN7021..... 70 Hardtop, Disc Only *, 2-Piece.
CIN7022..... 70 Convertible, Disc Only *, 2-Piece
CIN7131.....71-72..... Hardtop, (Also 70 Drum)
CIN7132.....71-72..... Convertible, (Also 70 Drum)
AIN8601..... 81 Hardtop, Grand National
AIN8601..... 81-87..... Hardtop, Grand National
AIN8201..... 82 Hardtop, Grand National
QIN8606..... 86 Skyhawk, Line 1 of 2
QIN8607..... 86 Skyhawk, Line 2 of 2

REAR AXLE BRAKE LINES

Rear axle brake lines include a pair of lines that run across the rear axle housing. These lines connect the wheel cylinders or calipers to the flex hose in the middle of the rear end. These lines work with original housings that use factory brakes. Modifications such as rear disc brakes or narrowed rear ends will likely require special lines. Call for more information.

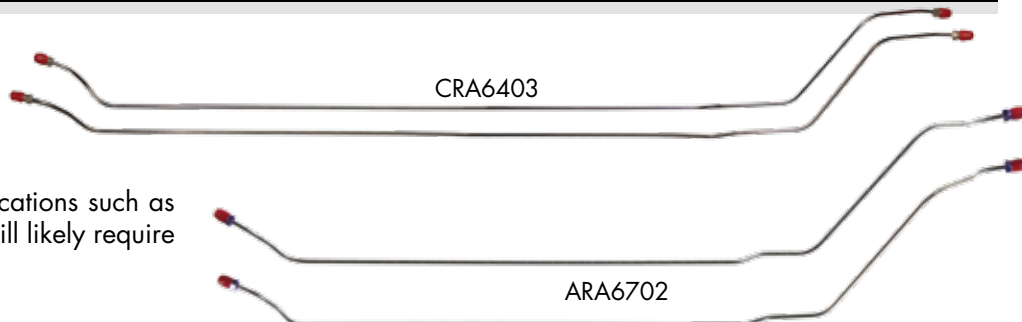

ADD "S" TO PART NUMBER FOR STAINLESS STEEL

CRA6403.....64-66..... All Cars
ARA6702..... 67 All Cars
ARA6804.....68-72..... All Cars

ARA8601..... 81 Grand National
ARA8201..... 82 Grand National
ARA8601..... 83-87..... Grand National

DISC BRAKE CALIPER LINES

Front disc caliper lines connect the front flex hoses to the calipers. They were typically used on 4 piston calipers in the late 1960's. Several fitting sizes were available from the factory. Please verify fitting sizes before ordering as rebuilt calipers may not match the originals.



ADD "S" TO PART NUMBER FOR STAINLESS STEEL

- AFC6701 ...67 ... 3/8" x 3/8" with Armor 2 Pcs.
- AFC6702 ...67 ... 3/8" x 1/2" Right Port, 3/8" x 7/16" Left Port with Armor 2 Pcs.
- AFC6801 ...68 ... 3/8" x 3/8" 2 Pcs.
- AFC6802 ...68 ... 1/2" Right Port, 7/16" Left Port .. 2 Pcs.

DISC BRAKE CLIPS

Brake line clip sets contain all the clips needed to fasten the brake tubes to the frame or body of the car. Individual clips and fasteners are available on pages 284-285.



- ACS01564-65..... Complete Set, 9-Piece
- ACS01666-67..... Except RA & HO, 9-Piece
- ACS01766-67..... with RA & HO, 10-Piece
- ACS01868-69..... Complete Set, 8-Piece
- ACS01970..... Complete Set, 8-Piece
- ACS02071-72..... Complete Set, 8-Piece

BRAKE HOSE BRACKETS

These brackets and hardware are used to secure flex hoses to various parts of the vehicle. Front brackets are sold in pairs.



- RSBK10 64-68 ... Rear Hose Bracket, Used with Screw On Block
- RSBB01 64-68 ... Rear Hose Brass 'T' Block
- RSBK66 68..... 4 Piston Inlet Line Brackets (pr)
- RSBK70 68-72 ... Front Hose Bracket, Disc Only (pr)
- RSBK12 68-72 ... 12 Bolt Rear Hose Bracket
- PVB78 71-72 ... Disc Brake Valve Bracket
- FHC01 Correct Gold Cadmium Plated C Clips
- CW6901 ... 69-72 ... Copper Washer

FRONT FLEX HOSES

Flex hoses provide a flexible connection from the body or frame to the front calipers or wheel cylinders as they move during suspension travel. Available in O.E. rubber or braided stainless steel. Hoses are D.O.T. approved. Hoses are priced individually.



ADD "S" TO PART NUMBER FOR STAINLESS STEEL

- FH14.....67 Front Drum
- FH26.....67 Front Disc
- FH20.....68 Front Disc
- FH21 68-72 Front Drum
- FH20 69-72 Front Disc
- FH161 75-76 Front Disc
- FH08 77-78 Front Disc
- FH09 79 Front Disc
- FH204 80-83 Right Front Disc
- FH205 80-83 Left Front Disc

FRONT FLEX HOSES

Rear flex hoses carry brake fluid between the body of the car and the rear. Hoses are available in O.E. rubber and braided stainless steel. 'T' blocks are attached whenever factory correct. All of our hoses are D.O.T. approved. Prices are per hose.



ADD "S" TO PART NUMBER FOR STAINLESS STEEL

- FH2867 All Cars
- FH2568 All Cars
- FH06 69-72 All Cars
- FH5775 All Cars
- FH1576 All Cars
- FH13 77-79 All Cars
- FH206 80-81 All Cars
- FH207 82-84 All Cars
- FH208 85-90 All Cars

MINI KITS

Mini kits include a pair of spindles, caliper brackets, & backing plates. Kits are a great value to freshen up the front end on a restoration project, or to build out a drum to disc brake conversion.

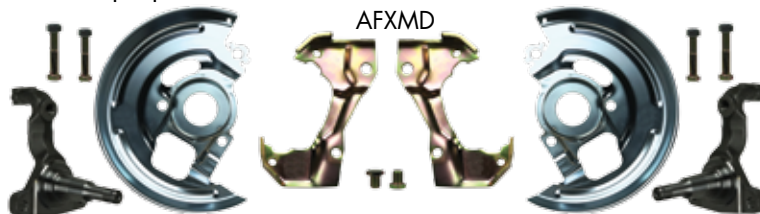

- AFXMD69-72 Mini Conversion Kit, Includes: Spindles, Backing Plates, Caliper Brackets
- AFXMD469-72 2" Drop, Single Piston Calipers
- AFXMD367-68 Standard Height, 4 Piston Piston Calipers

E-BRAKE CABLES

Parking brake cable sets contain all the individual cables and hardware needed to restore the system. Front, rear, & intermediate cables are also sold individually while supplies last. Sold in O.E. mild steel and stainless steel.

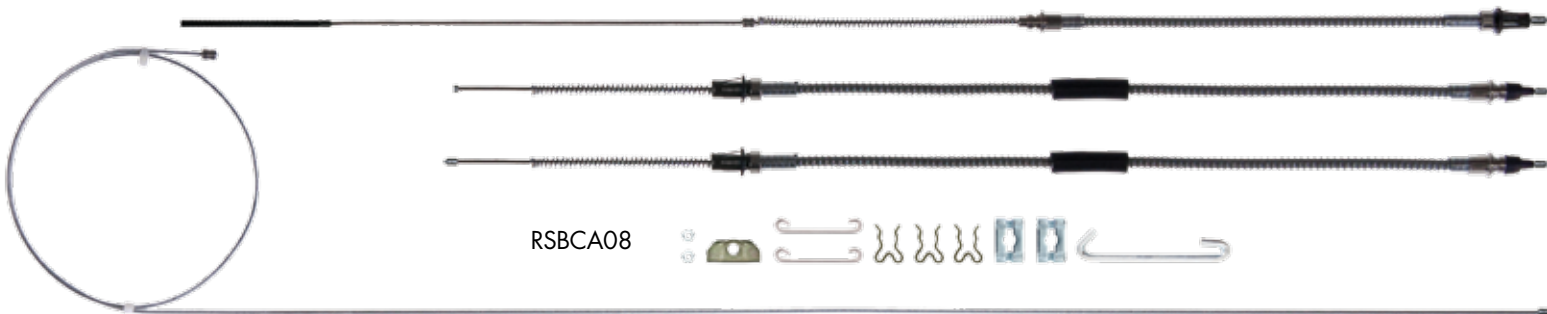

ADD "S" TO PART NUMBER FOR STAINLESS STEEL

• E-Brake Cable Kits

RSBCA08..... 64-67 Excluding Turbo 400
 RSBCA09.....67 Turbo 400
 RSBCA10..... 68-72 Excluding Turbo 400
 RSBCA11..... 68-72 Turbo 400
 RSBCA12..... 73-77 Century Regal, GS*
 RSBCA13..... 75-79 Skylark Apollo*
 RSBCA14..... 78-88 Grand National & Regal*

• Intermediate Brake Cables

EBC8013.....67 Skylark, Turbo 400
 EBC8014..... 68-72 Skylark, Excl. Turbo 400
 EBC8026..... 68-72 Skylark, TH400

• Rear Brake Cables

EBC9027..... 64-67 Skylark, Excl. Turbo 400
 EBC9001.....67 Skylark, Turbo 400
 EBC9007..... 68-72 Skylark, Excl. Turbo 400

• E-Brake Hardware

EBH1001..... 64-72 Jam Nut
 EBH3002..... 64-72 Center to Rear Silver Connector
 RSCLP23..... 64-72 Parking Brake Clip - Black
 EBH2002..... 64-67 Side Hook, Excl. T-400
 EBH2001..... 64-72 6" Silver Front Hook, Excl. T-400
 EBH3001..... 64-67 Olive Green Center Pull
 EBH2005.....67 Silver Rear Hook, T-400
 EBH2006.....67 Front Hook, T-400
 EBH2005..... 68-72 Silver Rear Hook
 EBH2006..... 68-72 Front Hook, Excl. T-400
 EBH2013..... 68-72 7 3/8" Hook, T-400

• Front Brake Cables

EBC7025..... 64-67 Skylark, Excl. Turbo 400
 EBC7010.....67 Skylark, Turbo 400
 EBC7001..... 68-72 Skylark, Excl. Turbo 400
 EBC7030..... 68-72 Skylark, Turbo 400

DRUM BRAKE SHOES

Shoes are sold in sets of four. Upgrade to the Silencer Precision series for quiet, low dust braking and longer shoe life.

SILENCER PRECISION



BS245

BS01..... 67-69..... 9" Drum Shoes, 2 Pair
 BS245..... 67-81..... 9" Drum Shoes, 2 Pair, Silencer Precision
 BS246..... 71-74..... Front Silencer Precision Shoes

DRUM BRAKES

Brake drums are sold individually.



BD0167-72.....Rear Drum, Finned

WHEEL CYLINDERS

Wheel cylinders are priced individually. Hardware is not included.



WC28.....65-66..... Left Front Wheel Cylinder
 WC29.....65-66..... Right Front Wheel Cylinder
 WC04.....65-67..... Rear Wheel Cylinder
 WC09..... 67 Left Front Wheel Cylinder
 WC10..... 67 Right Front Wheel Cylinder
 WC115.....68-72..... Left Front Wheel Cylinder
 WC116.....68-72..... Right Front Wheel Cylinder
 WC118.....68-74..... Rear Wheel Cylinder
 WC09.....73-74..... Left Front Wheel Cylinder
 WC10.....73-74..... Right Front Wheel Cylinder

SKYLARK/GS FRONT BRAKES & TRANS LINES

BRAKE CALIPERS

New calipers are supplied loaded with pads*, banjo bolts and copper washers. No core charge applies. Mounting pins are provided when applicable. Black and Red powder coating options provide a smooth, finished look that is unaffected by leaking brake fluid. *Rebuild and new 4 piston calipers do not include pads or hardware. Core charges apply as noted.

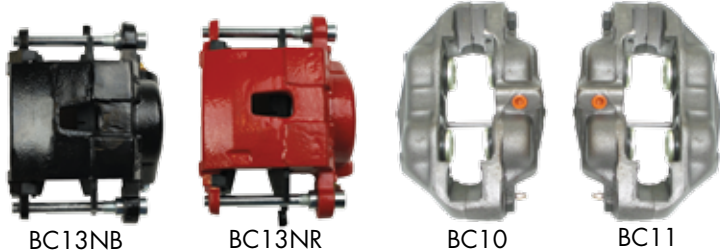

- BC10 67-68 4 Piston, Left, with Exchange
- BC10C 67-68 Core Charge
- BC11 67-68 4 Piston, Right, with Exchange
- BC11C 67-68 Core Charge
- CB6901 69 Caliper Bolts, Single Piston (ea.)
- BC14N 69-72 Left Front, New with pads
- BC15N 69-72 Right Front, New with pads
- BC1415 69-72 Red or Black Powdercoat (pr)
- BC0809 73-77 Red or Black Powdercoat (pr)
- BC12N 78-79 Left Front, Skylark/GS, New with pads
- BC13N 78-79 Right Front, Skylark/GS, New with pads
- BC1213 78-79 Skylark/GS - Red, Black, Powdercoat
- BC12N 78-87 Left Front, Regal/GN, New with pads
- BC13N 78-87 Right Front, Regal / GN, New with pads
- BC1213 78-87 Regal / GN - Red, Black, Powdercoat

DISC BRAKE PADS

Brake pads are sold in sets of four. Our base line is a midgrade standard offering. Step up to the Silencer Professional line for less dust, quieter braking, and longer pad life.



SILENCER PROFESSIONAL

- DP01 67-68 4 Piston Caliper Pads (2 pr) - Standard
- DP02 69-77 Single Piston Front Pads (2 pr) - Silencer
- DP02P 69-77 Single Piston Front Pads (2 pr) - Standard
- DP23 78-87 Single Piston Front Pads (2 pr) - Silencer
- DP23P 78-87 Single Piston Front Pads (2 pr) - Standard
- DP23 64-88 Rear Pads (2 pr), with RSD Rear Disc - Silencer
- DP23P 64-88 Rear Pads (2 pr), with RSD Rear Disc - Standard

TRANSMISSION VACUUM LINES

Transmission vacuum lines connect automatic transmissions to intake vacuum.

- ATV6805 68-72 with Turbo 400
- ATV6870 70 455 with T-400

BRAKE ROTORS

Brake rotors are shipped with bearing races installed. A Drilled-Slotted-Zinc Plated option is available on select rotors.



- BR01C 67-68 Front Rotor, 4 Piston, 1 Pc Design
- BR69C 67-69 Front Rotor, 4 Piston, 2 Pc Design
- BR02C 69-72 Front Rotor, 1 Pc Design
- BR03C 73-78 Front Rotor, Excl. '78 Regal, GN, GNX
- BR07C 78 Front Rotor, Regal, GN, GNX
- BR22C 79 Front Rotor, All
- BR22C 80-81 Front Rotor, Regal, GN, GNX
- BR03C 80-84 Front Rotor Excl. Regal, GN, GNX
- BR08C 82-87 Front Rotor, Regal, GN, GNX
- BR03C 85 Front Rotor, Skylark

TRANSMISSION COOLER LINES

Transmission cooler lines are sold as pairs. Be sure to verify the type of transmission in your project before ordering. These lines are intended to work only with factory motor, transmission, and radiator combinations.



- ATC6401 64 with Super Turbine 300 2 Pcs.
- ATC5701 57 All Cars
- ATC5901 59 All Cars
- ATC6705 67 with Turbo 400
- ATC6805 .. 68-72 ... T350/T400
- ATC8601 .. 81-87 ... Grand National, Excl. '82 4 Pcs.
- ATC8201 82 Grand National 2 Pcs.

SPINDLES

Our spindles are forged steel with precision CNC machining. Two hard to find caliper mounting bolts are included with each pair of spindles. 2" drop installations require caliper bracket and backing plate modifications. All listings are for disc brake systems. Call for drum brake applications.



- DBSP01 67-72 Disc Brake Spindles with Large Bolts (pr)
- DBSP04 67-72 2" Drop Disc Brake Spindles with Bolts (pr)

SKYLARK/GS BRAKE BOOSTERS & COMBOS

SLIMLINE BOOSTER MASTER COMBOS

J81315672

The slimline combos offer clean lines and plenty of power in a small package. The 8" dual is our favorite. Mounting brackets included.



J81315672 TOP VIEW

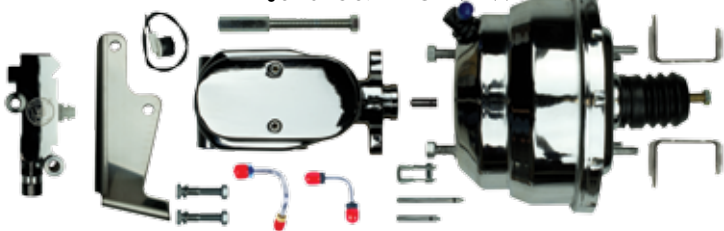

- G81310971 64-72 Gold 8" Dual, Disc/Drum
- J81315171 64-72 Chrome 8" Dual Disc/Drum
- G81310572 64-72 Gold 8" Dual, Disc/Disc
- J81315672 64-72 Chrome 8" Dual Disc/Disc
- G91020971 64-72 Gold 9" Single, Disc/Drum
- G91020572 64-72 Gold 9" Single, Disc/Disc

SLIMLINE BOOSTERS

Slimline boosters pack a lot of punch in a small, sleek package. Dual diaphragm versions provide 25% - 35% more assist than their single diaphragm equivalent. The 8" dual is our most popular for clearing big blocks while providing plenty of assist for two or four wheel disc brake systems. Mounting brackets included.



RPB7137



RPB7137C



RPB8131



RPB8131C

- RPB7137 64-72 7" Dual, Standard Gold
- RPB7137C 64-72 7" Dual, Chrome Plated
- RPB7137S 64-72 7" Dual, Polished Stainless
- RPB8131 64-72 8" Dual, Standard Gold
- RPB8131C 64-72 8" Dual, Chrome Plated
- RPB8131S 64-72 8" Dual, Polished Stainless
- RPB9102 64-72 9" Single, Standard Gold

DELCO BOOSTER MASTER COMBOS

Factory style for 67-72 GM. Can be tight on big block cars. The 11" is our most popular booster. Available with or without Delco stamping. Brackets included.



G91210971

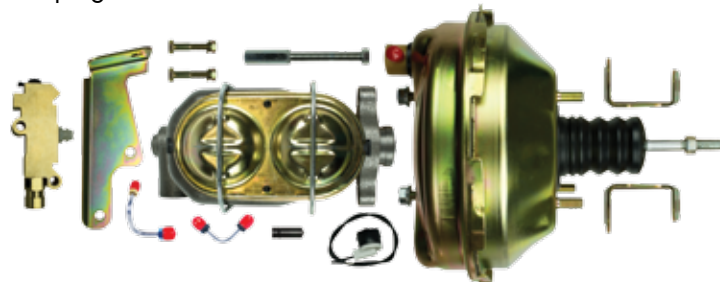

- 9" fits 1964-66 Factory and 11" fits 1967-72
- G91210971 64-72 Gold 9" Single Disc/Drum
- J91215171 64-72 Chrome 9" Single, Disc/Drum
- G91210572 64-72 Gold 9" Single Disc/Disc
- J91215672 64-72 Chrome 9" single, Disc/Disc
- G10030971 67-72 Gold 11" Single Disc/Drum
- J10035171 67-72 Chrome 11" Single, Disc/Drum
- G10030572 67-72 Gold 11" Single Disc/Disc
- J10035672 67-72 Chrome 11" Single, Disc/Disc

DELCO BOOSTERS

Reproductions based on original factory units. GM licensed & feature a Delco Moraine stamping. This logo is available right side up and upside down. Unstamped boosters are of identical quality, but less expensive without the licensing fees. Includes mounting brackets.



RPB1001



RPB1003



- RPB9121 64-66 9" Single Gold
- RPB9016 64-66 9" Standard Gold, with Delco Stamping
- RPB9121C 64-66 9" Single Chrome
- RPB1001 64-72 11" Single, Gold with Delco Stamp
- RPB1008 67-72 11" Single, Gold Upside Down Stamp
- RPB1003 67-72 11" Single Gold
- RPB1003C 67-72 11" Single Chrome

SKYLARK/GS MASTER CYLINDERS & FUEL TANKS

MASTER CYLINDERS

Most master cylinders are completely new units with no core charge. A deep cylinder pocket with a removable plug provides compatibility with manual brakes as well as power-assisted applications.



- DBMC0567-69... Power Disc, 1" Bore, Deep Pocket
- DBMC0864-66... Drum, Single Outlet, 1" Bore
- DBMC0767-72... Drum, 1" Bore, ** Rebuilt
- DBMC0967-70... Power Disc, 1-1/8" Bore
- DBMC1167-69... Power Disc, with Bleeders, 1-1/8" Bore, Deep, Exact Repo for '69, Delco Licensed
- DBMC1667-69... Power Disc, with Bleeders, 1-1/8" Bore, Deep, Same as DBMC11 without Casting Marks
- DBMC09C ...67-69... 1-1/8" Bore, Chrome
- DBMC05C ...67-69... 1" Bore, 4 Wheel Disc, Chrome
- DBMC51C...67-69... 1-1/8" Bore, Slimline Flat Top, Chrome
- DBMC56C...67-69... 1" Bore, Slimline Flat Top, Chrome
- DBMC0169-76... Power Disc, 1-1/8" Bore, Shallow
- DBMC19 70..... Power Disc, 1-1/8" Bore, Square with Bleeders

VAPOR RETURN LINES

Emission control systems use these 5/16" lines to handle fuel vapors. Some vehicles use a single front to rear line. Others utilize a charcoal canister and require 3 or 4 additional small lines. Multiple piece sets are noted.

- AGL7024..... 70-72 ... 5/16" Vapor, Hardtop2 Pcs.
- AGL7029..... 70-72 ... 5/16" Vapor, Convertible.....2 Pcs.
- AGL8602..... 81..... 5/16" Grand National
- AEM8201 82..... 5/16" Grand National
- QGL8605 86..... 5/16" Skyhawk
- AEM8701 87..... Vapor Return Set 4 Pcs.

VALVES & BLOCKS

We offer a full line of metering blocks, proportioning valves, distribution blocks and combination valves for factory drum and disc brake applications.

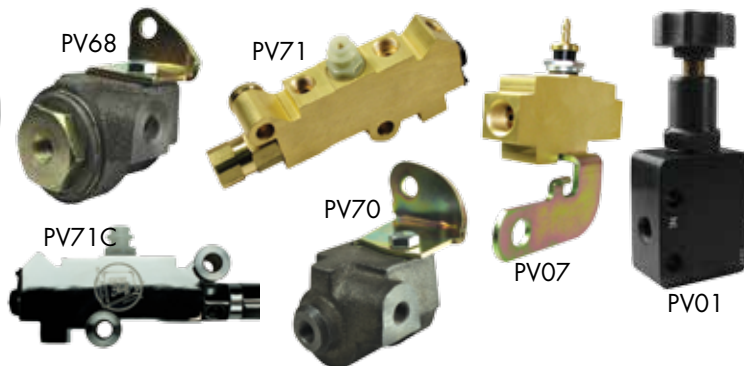

- PV01 All Adjustable Valve
- PV6867-69..... Factory Hold-Off Valve with Bracket
- PV0667-69..... Distribution Block
- PV70 70 Factory Hold-Off Valve with Bracket
- PV0770-72..... Distribution Block
- PV7171-72..... Disc/Drum Combination Valve, Brass
- PV71C.....71-72..... Disc/Drum Combination Valve, Chrome
- PV7271-72..... Disc/Disc Combination Valve, Brass
- PV72C.....71-72..... Disc/Disc Combination Valve, Chrome
- PVB7871-72..... Disc Brake Valve Bracket
- AMB7001..... Proportioning Valve

FUEL TANK VENT LINES

Fuel tank vent lines allow the air inside the fuel tank to escape as it is filled with fuel. They also prevent pressure from building up due to temperature changes.

- AFV8201 82..... Tank Vent Lines - OE Steel3 Pcs.
- AFV8201S..... 82..... Tank Vent Lines - Stainless3 Pcs.



MAIN FUEL LINES

Main lines carry fuel from the tank in the rear of the car to the fuel pump or rail in the front. They are available in 3/8" and 5/16" tubing based on factory specifications. Multiple piece sets are noted. Call for 1/2" lines.

AGL7025

ADD "S" TO PART NUMBER FOR STAINLESS STEEL

AGL6201 ... 62-63 ... 5/16" Hardtop
 AGL6411 ... 64-66 ... 5/16" Hardtop
 AGL6431 ... 64-66 ... 3/8" Hardtop
 AGL6412 ... 64-66 ... 5/16" Convertible
 AGL671167 5/16" Hardtop
 AGL671767 5/16" Convertible Main Line
 AGL6811 ... 68-69 ... 3/8" Hardtop without ECS

AGL6812 ... 68-69 ... 3/8" Convertible without ECS*
 AGL7025 ... 70-72 ... 3/8" Main Line, Hardtop2 Pcs.
 AGL7027 ... 70-72 ... 3/8" Convertible2 Pcs.
 AGL860181 3/8" Grand National3 Pcs.
 AGL820182 3/8" Grand National
 QGL860686 3/8" Skyhawk
 AGL870187 3/8" 3.8 Turbo2 Pcs.
 *Emission Control System

RETURN FUEL LINES

Return lines carry excess fuel from fuel pump or fuel filter back to the tank. Not all vehicles were equipped with a return line. They are typically made of 1/4" diameter tubing. Multiple piece sets are noted.

ADD "S" TO PART NUMBER FOR STAINLESS STEEL

AGL671867 1/4" Convertible
 AGL681368-69 1/4" Hardtop
 AGL681468-69 1/4" Convertible
 AGL702670-72 1/4" Hardtop2 Pcs.
 AGL702870-72 1/4" Convertible2 Pcs.
 AGL860381 1/4" Grand National2 Pcs.
 AGL820282 1/4" Grand National
 QGL860486 1/4" Skyhawk2 Pcs.
 AGL870287 1/4" Return Line

FUEL LINE CLIPS

Fuel line clips hold tubing to the frame or body of the car. Fasteners are included as noted. See p. 290-291 for individual clips.

ADD "S" TO PART NUMBER FOR STAINLESS STEEL

ACS02164-67 with 5/16" Fuel Line Only
 ACS02264-67 with 3/8" Fuel Line Only
 ACS02364-67 with 5/16" Fuel Line & 1/4" Return
 ACS02464-67 with 3/8" Fuel Line & 1/4" Return
 ACS02568-69 with 3/8" Fuel Line & 1/4" Return
 ACS02670 with 3/8" Fuel Line & 1/4" Return
 ACS02770 with 3/8" Fuel Line Only
 ACS02871-72 with 3/8", 1/4" & 5/16" EMS
 ACS02971-72 with 3/8" Fuel Line

FUEL PUMP TO CARB LINES

Fuel pump to carburetor lines connect the fuel pump to the carburetor. Brass blocks and fittings are included as noted. These lines are intended to work only with factory pump, motor, intake and carburetor combinations.

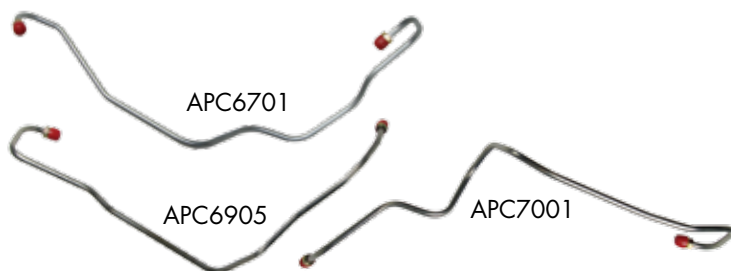

ADD "S" TO PART NUMBER FOR STAINLESS STEEL

APC6701 67-68 400 with 4 BBL
 APC6805 68-72 350 with 4 BBL
 APC690269 350 with 2 BBL
 APC6904 69-72 400 or 455, Except Stage 1
 APC6905 69-72 400 or 455, Stage 1
 APC7001 70-72 350 with 2 BBL
 FPC780278 301 with Quadrajet
 APC8208 78-83 3.8L Turbo

OIL COOLER LINES

AOL8601 81 Oil Cooler Line
 AOL8601S 81 Oil Cooler Line - Stainless
 ATL8201 82 Oil Cooler Line
 ATL8201S 82 Oil Cooler Line - Stainless

SUSPENSION COMPONENTS

UPPER & LOWER BALL JOINTS



XK5103 XK5108

XK510364-72.....Lower
 XK510864-72.....Upper
 XK614575-79.....Lower
 XK520875-79.....Upper

UPPER & LOWER CONTROL ARM BUSHING KITS



XK5196

XK514464-65.....Lower
 XK607666-72.....Lower
 XK519666-72.....Upper

INNER & OUTER TIE RODS & SLEEVES

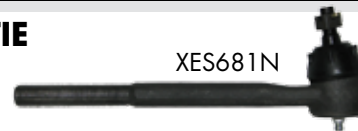

XES681N

XES681N64-70.....Inner
 XES333RL64-70.....Outer
 XES2032S ...64-70.....Adjusting Sleeve
 XES2004S ...71-79.....Adjusting Sleeve

IDLER ARMS

CIA640164-67.....Idler Arm with 7/8" Center Link
 CIA6801 64Idler Arm with 3/16" Center Link
 CIA680168-72.....Idler Arm with 3/16" Center Link

STEERING ARMS

DBSA0164-72.....Steering Arm, 1/2" Bolt Hole (pr)

SUSPENSION KITS

Standard rubber kits meet O.E. specifications. Polyurethane kits provide better handling and a firmer ride. Poly kits include upgraded control arm bushings, sway bar bushings, and sway bar links. Pre-packaged kits offer huge savings over individual suspension parts. Most kits include the following:

- Lower Ball Joints (2)
- Upper Ball Joints (2)
- Lower Ctrl. Arm Bushings (4)
- Upper Ctrl. Arm Bushings (4)
- Inner Tie Rods (2) (Extra Value)
- Sway Bar Link Kits (2)
- Tie Rod Adj. Sleeves (2)
- Sway Bar Bushings (2)
- Outer Tie Rods (2)

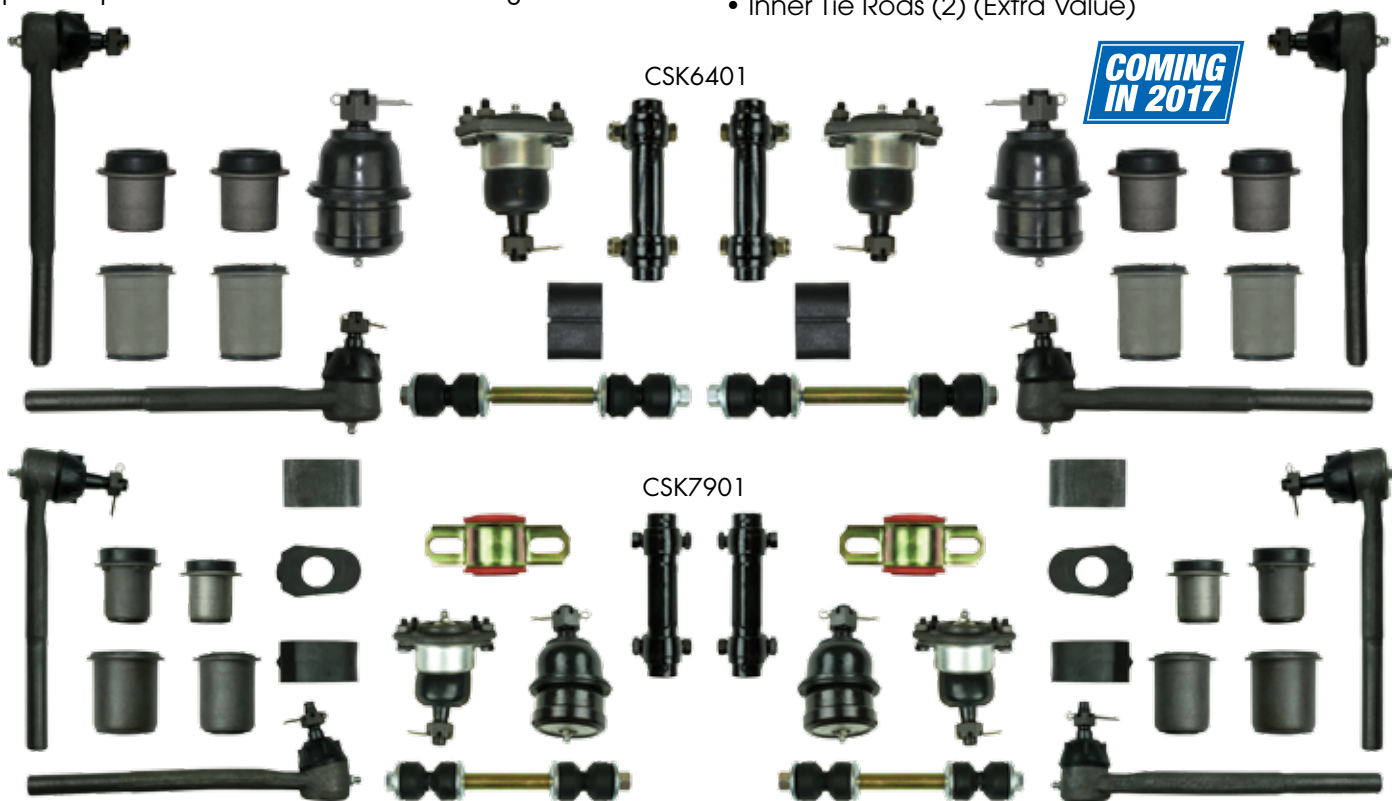

CSK6401

**COMING
IN 2017**

CSK7901

CSK640166-70... Kit, Circular Hole in Ctrl. Arm, 22-Piece
 CSK6401U ..66-70... Kit, Circular Hole in Ctrl. Arm, 22-Pc (Poly)
 CSK700170-72... Kit, Oval Hole in Ctrl. Arm, 22-Piece.
 CSK7001U ..70-72... Kit, Oval Hole in Ctrl. Arm, 22-Pc (Poly)
 CSK750175-77... Manual Steering, All

CSK750175-77... Power Steering, Rally Sport
 CSK790178-79... Manual Steering, All
 CSK790178-79... Power Steering, Rally Sport
 CSK790278-79... Power Steering, Excl. Rally Sport

FRONT BRAKE LINE KITS

Front brake line kits consist of all brake lines under the hood. This includes the master cylinder to the distribution, combination or metering valve. The left and right front lines that run to the front flex hoses are also included. Call for individual component pricing. These line kits are for vehicles with factory brake systems.

ADD "S" TO PART NUMBER FOR STAINLESS STEEL

QBS4001 40.....	Model 41, Full Brake Set.....	6 Pcs.
QBS4100 41.....	Full Brake Line Set	11 Pcs.
QKT4201	.. 42-48 ..	Roadmaster, Std. Drum.....	3 Pcs.
QKT5001 50.....	Standard Drum.....	3 Pcs.
QBS5401 54.....	Std Drum 56R Full Brake Line...6 Pcs.	
QKT5602 56.....	Roadmaster, Power Drum	3 Pcs.
QKT5701 57.....	Roadmaster, Standard Drum	3 Pcs.
QKT5801 58.....	Roadmaster, Standard Drum	4 Pcs.
QBS5901 59.....	Complete Brake Line Set.....	8 Pcs.
QKT6301 63.....	LeSabre & Wildcat, Power Drum	3 Pcs.
QKT6303 63.....	Buick Special, Std Drum	3 Pcs.
QKT6401 64.....	Wildcat, Standard Drum	3 Pcs.
QKT6501	.. 64-65 ..	Riviera, Standard Drum	3 Pcs.
QKT6601 66.....	Electra, Standard Drum	3 Pcs.
QKT6703 67.....	Wildcat, Power Drum.....	4 Pcs.
QKT6707 67.....	Wildcat, Power Disc	7 Pcs.
QKT6801 68.....	LeSabre, Manual Drum	4 Pcs.
QKT7005 70.....	LeSabre, Power Drum.....	4 Pcs.
QKT7201 71.....	Riviera Only, Power Disc	4 Pcs.
QKT7103	.. 71-72 ..	All Excl. Riviera, Power Disc	4 Pcs.
QKT7301 73.....	Riviera	4 Pcs.
QKT7701 77.....	LeSabre, Power Disc	4 Pcs.
QKT9001 90.....	Estate Wagon	4 Pcs.

VACUUM LINES

QBV6501 65-66...	Power Booster Line - OE Steel
QBV6501S	.. 65-66...	Power Booster Line - Stainless
QBV6601 66	425 ci 2x4 BBL Vacuum Tube - OE
QBV6601S 66	425 ci 2x4 BBL Vacuum Tube - Stainless

MISCELLANEOUS LINES

ADD "S" TO PART NUMBER FOR STAINLESS STEEL

QOL5002 50	320 ci, Filter to Pan
QDV5002 50	320 ci, Distributor Vacuum
QPV5002 50	Fuel Pump to Carb Vacuum
QWV5002	... 50	Wiper Vacuum
QWV5002	... 67	Caliper Inlet Lines

FRONT TO REAR BRAKE LINES

Front to rear brake lines go from the distribution, combination or metering valve along the length of the vehicle to the rear flex hose. Lines are manufactured in 1 or 2 pieces based on factory specifications.

ADD "S" TO PART NUMBER FOR STAINLESS STEEL

QIN4201 42-48.....	Roadmaster, Left & Right.....	2 Pcs.
QIN5003 50	Wagon	
QIN5601 56	Roadmaster	
QIN5701 57-58.....	Roadmaster.....	2 Pcs.
QIN6301 63	LeSabre & Wildcat	
QIN6303 63	Buick Special	
QIN6401 64	All	
QIN6502 65	Buick LeSabre, All	
QIN6601 66	Electra	
QIN6701 67	All	
QIN6801 67	LeSabre	
QIN7001 70	Electra	
QIN7201 71	Riviera	
QIN7132 71-72....	Centurion, Conv. Power Disc	
QIN7301 73	Riviera	
QIN7701 77	LeSabre	

REAR AXLE BRAKE LINES

Rear axle brake lines include a pair of lines that run across the rear axle housing. These lines connect the wheel cylinders or calipers to the flex hose in the middle of the rear end. These lines work with original housings that use factory brakes. Modifications such as rear disc brakes or narrowed rear ends will likely require special lines. Call for more information.

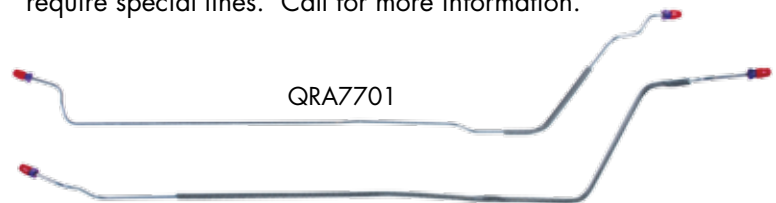

ADD "S" TO PART NUMBER FOR STAINLESS STEEL

QRA5601 56	Roadmaster
QRA5701 57-58.....	Roadmaster
QRA6301 63-64.....	LeSabre & Wildcat
QRA6303 63	Buick Special
QRA6501 64	425 ci, Electra & Riviera
QRA6502 65	Buick LeSabre, All
QRA6601 66	Electra
QRA6702 67	All Cars
QRA6801 68	LeSabre
QRA7001 70	Electra
QRA7201 71	Riviera
QRA7102 71-72.....	All Cars, Excl. Riviera
QRA7301 73	Riviera
QRA7701 77	LeSabre

FULL SIZE BUICK BRAKE HOSES & CYLINDERS

FRONT FLEX BRAKE HOSES

Flex hoses provide a flexible connection from the body or frame to the front calipers or wheel cylinders as they move during suspension travel. Choose between O.E. rubber or braided stainless steel. All of our hoses are D.O.T. approved. Hoses are priced individually.

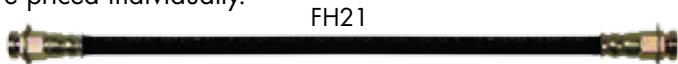

ADD "S" TO PART NUMBER FOR STAINLESS STEEL

- FH02..... 67-68 Front Disc
- FH21..... 69-70 Front Disc
- FH08..... 71-73 Front Disc
- FH161..... 74-76 Front Disc
- FH170..... 77-78 Front Disc
- FH171..... 79-85 Front Disc

REAR FLEX BRAKE HOSES



ADD "S" TO PART NUMBER FOR STAINLESS STEEL

- FH209.....67 All Cars
- FH10.....68 All Cars
- FH178..... 69-70 All Cars
- FH13..... 74-85 All Cars

WHEEL CYLINDERS

Wheel cylinders are priced individually. Hardware not included.



- WC20.....58-60..... Left Front
- WC21.....58-60..... Right Front
- WC106.....61-66..... Left Front, with Horizontal Mounting Holes
- WC107.....61-66..... Right Front, with Horizontal Mounting Holes
- WC119.....61-66..... Left Front, with Diagonal Mounting Holes
- WC120.....61-66..... Right Front, with Diagonal Mounting Holes
- WC121.....67-68..... Left Front
- WC122.....67-68..... Right Front
- WC123.....69-70..... Left Front
- WC124.....69-70..... Right Front
- WC125.....50-70..... Left Rear
- WC126.....50-70..... Right Rear
- WC58.....71-75..... All Cars
- WC127.....76..... All Cars
- WC58.....77-84..... 11 x 2 Brakes
- WC128.....85-86..... 11 x 2 Brakes



FUEL PUMP TO CARB LINES

Fuel pump to carburetor lines connect the fuel pump to the carburetor. Brass blocks and fittings are included as noted. These lines are intended to work only with factory pump, motor, intake and carburetor combinations.

ADD "S" TO PART NUMBER FOR STAINLESS STEEL

QPC5002..... 50.....320 ci, 1 BBL
 QPC6402.. 64-65 ...Dual Carter AFB 4's, 2 Lines with Block
 QPC6506.. 65-66 ...425 ci 2x4 BBL Carb to Filter
 QPC6507.. 65-66 ...425 ci 2x4 BBL 2nd Fuel line
 QPC6707.... 67.....V-8, 4 BBL
 APC6701 .. 67-68 ...400 with 4 BBL
 APC6805 .. 68-72 ...350 with 4 BBL
 APC6902 69.....350 with 2 BBL
 APC6904 .. 69-72 ...400 or 455, Except Stage 1
 APC6905 .. 69-72 ...400 or 455, Stage 1
 APC7001 .. 70-72 ...350 with 2 BBL
 QPC7201 71455, 4 BBL, Riviera
 QPC7301 73.....Riviera P/C 455 ci 4 BBL
 QPC7701 77.....LeSabre, V-8
 FPC7802 78.....301 with Quadrajel

MAIN FUEL LINES

Main lines carry fuel from the tank in the rear of the car to the fuel pump or rail in the front. They are available in 3/8" and 5/16" tubing based on factory specifications. Multiple piece sets are noted. Call for 1/2" lines.

ADD "S" TO PART NUMBER FOR STAINLESS STEEL

QGL5501 55.....Main Fuel Line
 QGL5601 56.....Roadmaster, Main Line
 QGL6301 63-64 3/8" Wildcat Convertible
 QGL6402..... 63-65 3/8" Main Line, Riviera
 QGL6501 64-65 3/8" Main, All, Buick LeSabre
 QGL6601 66..... 3/8" Main Fuel Line
 QGL6701 67..... 3/8" Main Fuel Line
 QGL7201 71 3/8" Riviera
 QGL7101 71-72 3/8" Centurion Convertible
 QGL7301 73..... 3/8" Riviera
 QGL7701 77..... 3/8" LeSabre

VAPOR RETURN LINES

Emission control systems use these 5/16" lines to handle fuel vapors. Some vehicles use a single front to rear line. Others utilize a charcoal canister and require 3 or 4 additional small lines. Multiple piece sets are noted.

ADD "S" TO PART NUMBER FOR STAINLESS STEEL

QEM7201 71Riviera, 4 Pc. Vapor Set
 QGL7303..... 73.....5/16" Centurion Convertible
 QGL7303..... 73.....5/16" Riviera
 QEM7701 77.....5/16" Vapor

TRANSMISSION COOLER LINES

Transmission cooler lines are sold as pairs. Be sure to verify the type of transmission in your project before ordering. These lines are intended to work only with factory motor, transmission, and radiator combinations.

ADD "S" TO PART NUMBER FOR STAINLESS STEEL

QTC5601 56.....Specialty, Dynaflo
 QTC5701 57.....All Cars
 QTC6301 63.....LeSabre
 QTC6401 64.....425 ci, Electra & Riviera
 QTC6502..... 65.....Buick LeSabre, All
 QTC6601 66.....Turbo 400, Electra
 QTC6901 69.....Turbo 400, Electra
 QTC7201 71Turbo 400, Riviera
 QTC7301 73.....Turbo 400 Riviera 455 ci
 QTC7401 74.....Turbo 350 LeSabre, V-8
 QTC7701 77LeSabre, V-8

TRANSMISSION VACUUM LINES

Transmission vacuum lines connect automatic transmissions to intake vacuum.

QTV7201 71 Turbo 400 - OE Steel
 QTV7201S 71 Turbo 400 - Stainless
 QTV7301 73..... Turbo 400 Riviera 455ci - OE Steel
 QTV7301S 73..... Turbo 400 Riviera 455ci - Stainless

THERMAL CHOKE LINES

Thermal choke lines carry heat from the exhaust system to the choke coil on the carburetor. Some applications route thru the intake manifold on their way to the carburetor.

ADD "S" TO PART NUMBER FOR STAINLESS STEEL

QCH6566 ...65-66... 4 bbl Carter Choke Control Line
 QCH5801 58..... 2 bbl Stromberg Choke Control Line
 QCH5701 57..... 4 bbl Carter AFB Choke Control Line

RETURN FUEL LINES

Return lines carry excess fuel from fuel pump or fuel filter back to the tank. Not all vehicles were equipped with a return line. They are typically made of 1/4" diameter tubing. Multiple piece sets are noted.

ADD "S" TO PART NUMBER FOR STAINLESS STEEL

QGL6401 63-65 1/4" Riviera
 QGL6502..... 64-65 1/4" All, Buick LeSabre
 QGL6702..... 67 1/4" Return
 QGL7202..... 71 1/4" Riviera
 QGL7102..... 71-72 1/4" Centurion Convertible
 QGL7302..... 73 1/4" Riviera

SKYLARK/GS FRONT BRAKE CONVERSIONS

**STREET
SERIES**

FRONT DISC BRAKE CONVERSION KITS

U.S.A. Made
TIMKEN Bearings

FRONT CONVERSIONS INCLUDE:

- 11" Rotors
- Spindles (OE or 2" Drop)
- Timken Bearings
- New Calipers
- Caliper Brackets
- Organic Pads
- Backing Plates
- Flex Hoses & Clips
- Valve Bracket & Hardware
- Banjo Bolts & Copper Washers
- Dust Caps
- Castle Nuts & Pins
- Washers
- Grease Seals
- Spindle Gaskets
- Steering Arm Bolts
- Master Cylinder
- Combination Valve
- Pedal Rod Extension
- Brake Switch Pigtail

Right Stuff disc conversions are the most complete kits in the industry at the right price. High quality components, professional packaging, and after-sale support by "hands-on" technicians create an unbeatable value. Consider one of our complete brake line packages for a carefree installation.



Packages include At-the-Wheel Disc Conversion Kit & Master Cylinder with Valve (Manual) or Master Cylinder with Booster and Valve (Power).

POWER PACKAGE

MANUAL PACKAGE

9" or 11" inch booster, Call for other diameters

UPGRADES

The next page offers upgrades to fully customize your conversion kit.

WORKS WITH FACTORY 14" DISC BRAKE WHEELS

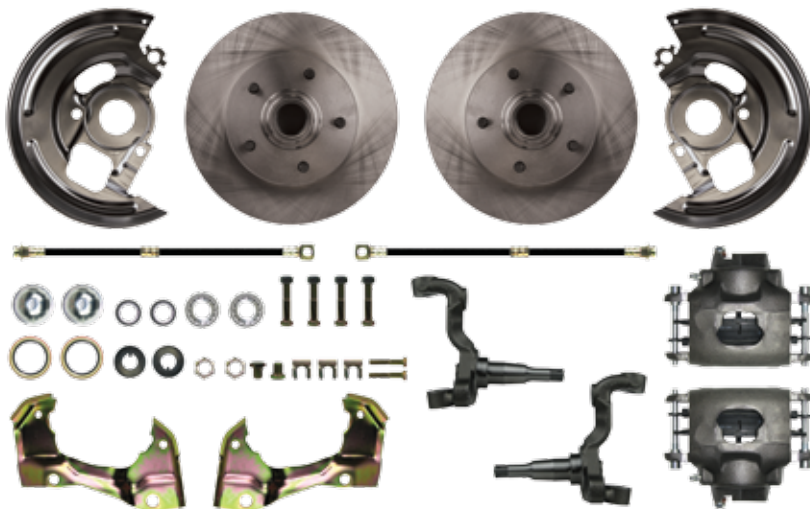

AT-THE-WHEEL FRONT KITS From

STOCK HEIGHT FRONT KITS

- AFXWK01C64-72..... At-the-Wheel Disc Conversion Kit
- AFXSD01C.....64-72..... Manual Disc Conversion Package
- AFXDC01C64-72..... 9" Power Disc Conversion Package
- AFXDC06C67-72..... 11" Power Disc Conversion Package

2" DROP FRONT KITS

- AFXWK01D64-72..... At-the-Wheel Disc Conversion Kit
- AFXSD01D.....64-72..... Manual Disc Conversion Package
- AFXDC01D64-72..... 9" Power Disc Conversion Package
- AFXDC06D67-72..... 11" Power Disc Conversion Package



SKYLARK/GS FRONT BRAKE UPGRADES

FRONT DISC BRAKE CONVERSION UPGRADES

STREET SERIES

SHOW'N GO UPGRADE TRIM KITS

These At-the-Wheel Disc Conversion Kits (stock height or 2" drop) include upgraded drilled slotted rotors with zinc plating, powder coated calipers in red or black, and braided stainless hoses.



STOCK HEIGHT SHOW'N GO

AFXWK01CS 64-72 ... At-the-Wheel Disc Conversion Kit - Black
 AFXWK01CZ 64-72 ... At-the-Wheel Disc Conversion Kit - Red
 AFXSD01CS 64-72 ... Manual Disc Conversion Package - Black
 AFXSD01CZ 64-72 ... Manual Disc Conversion Package - Red
 AFXDC01CS 64-72 ... Power Disc Conversion Package - Black
 AFXDC01CZ 64-72 ... Power Disc Conversion Package - Red

2" DROP SHOW'N GO

AFXWK01DS 64-72 ... At-the-Wheel Disc Conversion Kit - Black
 AFXWK01DZ 64-72 ... At-the-Wheel Disc Conversion Kit - Red
 AFXSD01DS 64-72 ... 2" Drop Manual Disc Conv Pkg - Black
 AFXSD01DZ 64-72 ... 2" Drop Manual Disc Conv Pkg - Red
 AFXDC01DS 64-72 ... 2" Drop Power Disc Conv Pkg - Black
 AFXDC01DZ 64-72 ... 2" Drop Power Disc Conv Pkg - Red

SHOW STOPPER TRIM PACKAGES

Includes At-the-Wheel Front Disc Conversion Kit (stock height or 2" drop) with natural finish calipers. The Manual Packages get an upgraded chrome plated master cylinder and combination valve with bracket. Power Packages include an upgraded 8" dual chrome booster.

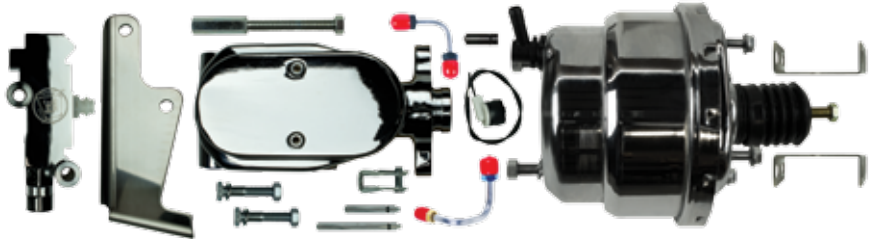

STOCK HEIGHT SHOW STOPPER

AFXSD01CX 64-72 ... Manual Disc Conversion Package
 AFXDC01CX 64-72 ... 8" Power Disc Conversion Package

2" DROP SHOW STOPPER

AFXSD01DX 64-72 ... Manual Disc Conversion Package
 AFXDC01DX 64-72 ... 8" Power Disc Conversion Package

BEST OF SHOW TRIM PACKAGES

Includes At-the-Wheel Front Disc Conversion Kit (stock height or 2" drop) with black or red calipers, drilled & slotted rotors & braided stainless hoses. The Manual Packages get an upgraded chrome plated master cylinder and combination valve with bracket. Power Packages include an upgraded 8" dual chrome booster.



STOCK HEIGHT BEST OF SHOW

AFXSD01CSX 64-72 ... Manual Disc Conversion Package - Black
 AFXSD01CZX 64-72 ... Manual Disc Conversion Package - Red
 AFXDC01CSX 64-72 ... 8" Power Disc Conversion Package - Black
 AFXDC01CZX 64-72 ... 8" Power Disc Conversion Package - Red

2" DROP BEST OF SHOW

AFXSD01DSX 64-72 ... Manual Disc Conversion Package - Black
 AFXSD01DZX 64-72 ... Manual Disc Conversion Package - Red
 AFXDC01DSX 64-72 ... 8" Power Disc Conversion Package - Black
 AFXDC01DZX 64-72 ... 8" Power Disc Conversion Package - Red



Disc Brake Conversions require special brake lines that fit your new disc conversion setup. Right Stuff offers "No Brainer" Brake Line Kits that include all components needed from your master cylinder back to your rear wheel cylinder or calipers. They include front brake line kit, front to rear line, rear axle lines & flex hose, & clip set.

See page 196 for your application

SKYLARK/GS 4-WHEEL BRAKE CONVERSIONS

**STREET
SERIES**

FOUR WHEEL DISC BRAKE CONVERSION KITS

U.S.A. Made
TIMKEN Bearings

FRONT CONVERSIONS INCLUDE:

- 11" Rotors
- Forged Spindles (OE or 2" Drop)
- Timken Bearings
- New Calipers
- Caliper Brackets
- Organic Pads
- Backing Plates
- Flex Hoses & Clips
- Valve Bracket & Hardware
- Banjo Bolts & Copper Washers
- Dust Caps
- Castle Nuts & Pins
- Washers
- Grease Seals
- Spindle Gaskets
- Steering Arm Bolts
- Master Cylinder
- Combination Valve
- Pedal Rod Extension
- Brake Switch Pigtail

REAR CONVERSIONS INCLUDE:

- 11" Rotors
- Caliper Brackets & Spacers
- Weld-On Hose Brackets
- Flex Hoses
- Backing Plates (Exclusive), not for AFXRD78 or AFXRDM78
- New Loaded Caliper
- E-Brake Cables
- Hardware

Right Stuff disc conversions are the most complete kits in the industry at the right price. High quality components, professional packaging, and after-sale support by "hands-on" technicians create an unbeatable value. Consider one of our complete brake line packages for a carefree installation. See page 191 to verify axle flange measurements for these kits.



Packages include At-the-Wheel Disc Conversion Kits & Master Cylinder with Valve (Manual) or Master Cylinder with Booster and Valve (Power).

WORKS WITH 15" AND LARGER WHEELS

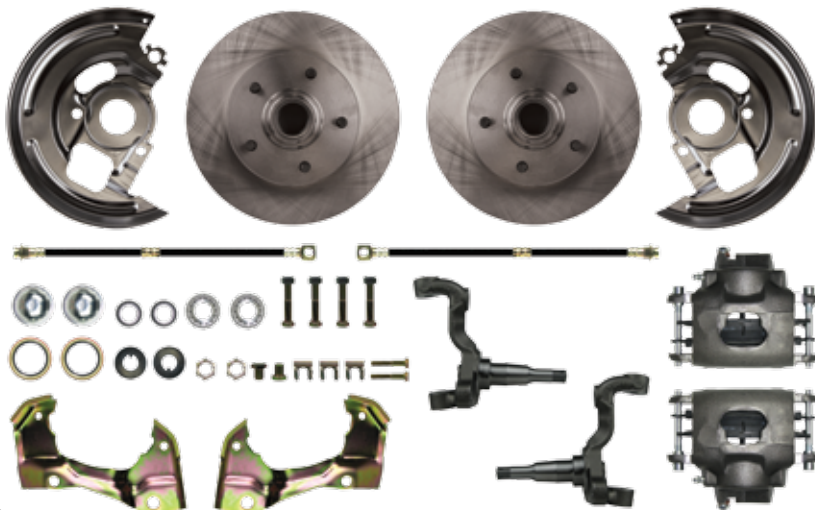

AT-THE-WHEEL FRONT KIT

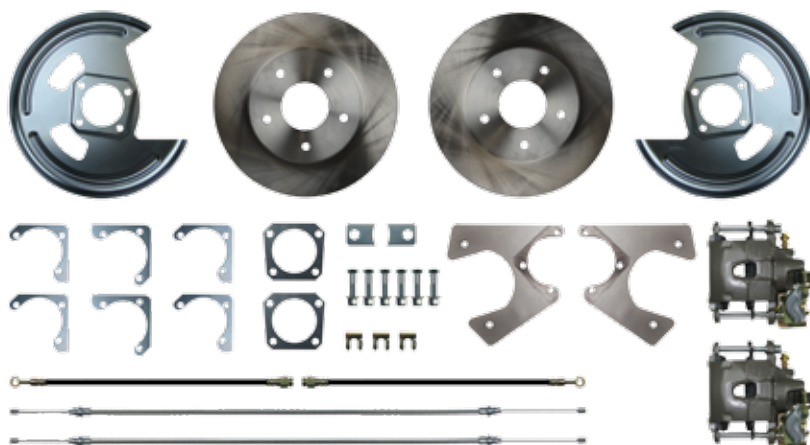

AT-THE-WHEEL REAR KIT

6-3/16" INSIDE ROTOR DIAMETER - 2.78" CENTER HOLE

STOCK HEIGHT 4-WHEEL KITS

- AFXSD41C... 64-72 ... Manual Disc Brake Conversion Package
- AFXDC41C ... 64-72 ... 9" Power Disc Brake Conversion Package
- AFXDC46C ... 67-72 ... 11" Power Disc Brake Conversion Package

2" DROP 4-WHEEL KITS

- AFXSD41D... 64-72 ... Manual Disc Brake Conversion Package
- AFXDC41D ... 64-72 ... 9" Power Disc Brake Conversion Package
- AFXDC46D ... 67-72 ... 11" Power Disc Brake Conversion Package



UPGRADES

The next page offers upgrades to fully customize your conversion kit.

SKYLARK/GS 4-WHEEL BRAKE UPGRADES

4-WHEEL DISC BRAKE CONVERSION UPGRADES **STREET SERIES**

SHOW'N GO UPGRADE TRIM KITS

These At-the-Wheel Disc Conversion Kits (stock height or 2" drop) include upgraded drilled slotted rotors with zinc plating, powder coated calipers in red or black, and braided stainless hoses.



STOCK HEIGHT SHOW'N GO

AFXSD41CS...64-72... Manual Disc Brake Conv Package - Black
 AFXSD41CZ...64-72... Manual Disc Brake Conv Package - Red
 AFXDC41CS...64-72... Power Disc Brake Conv Package - Black
 AFXDC41CZ...64-72... Power Disc Brake Conv Package - Red

2" DROP SHOW'N GO

AFXSD41DS...64-72... 2" Drop Manual Disc Brake Conv Pkg - Black
 AFXSD41DZ...64-72... 2" Drop Manual Disc Brake Conv Pkg - Red
 AFXDC41DS...64-72... 2" Drop Power Disc Brake Conv Pkg - Black
 AFXDC41DZ...64-72... 2" Drop Power Disc Brake Conv Pkg - Red

SHOW STOPPER TRIM PACKAGES

Includes At-the-Wheel Front Disc Conversion Kit (stock height or 2" drop) with natural finish calipers. The Manual Packages get an upgraded chrome plated master cylinder and combination valve with bracket. Power Packages include an upgraded 8" dual chrome booster.

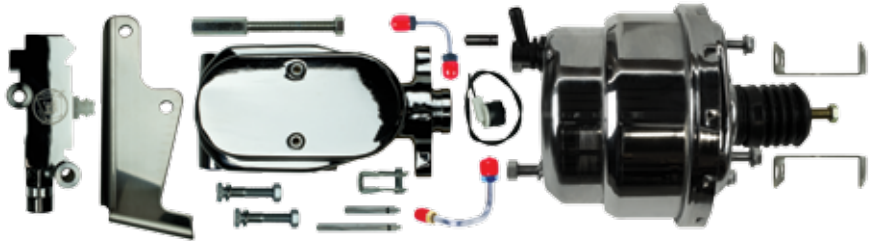

STOCK HEIGHT SHOW STOPPER

AFXSD41CX...64-72... Manual Disc Brake Conversion Package
 AFXDC41CX...64-72... 8" Power Disc Brake Conversion Package

2" DROP SHOW STOPPER

AFXSD41DX...64-72... Manual Disc Brake Conversion Package
 AFXDC41DX...64-72... 8" Power Disc Brake Conversion Package

BEST OF SHOW TRIM PACKAGES

Includes At-the-Wheel Front Disc Conversion Kit (stock height or 2" drop) with black or red calipers, drilled & slotted rotors & braided stainless hoses. The Manual Packages get an upgraded chrome plated master cylinder and combination valve with bracket. Power Packages include an upgraded 8" dual chrome booster.



STOCK HEIGHT BEST OF SHOW

AFXSD41CSX...64-72... Manual Disc Brake Conversion Pkg - Black
 AFXSD41CZX...64-72... Manual Disc Brake Conversion Pkg - Red
 AFXDC41CSX...64-72... 8" Power Disc Brake Conversion Pkg - Black
 AFXDC41CZX...64-72... 8" Power Disc Brake Conversion Pkg - Red

2" DROP BEST OF SHOW

AFXSD41DSX...64-72... Manual Disc Brake Conversion Pkg - Black
 AFXSD41DZX...64-72... Manual Disc Brake Conversion Pkg - Red
 AFXDC41DSX...64-72... 8" Power Disc Brake Conversion Pkg - Black
 AFXDC41DZX...64-72... 8" Power Disc Brake Conversion Pkg - Red



Disc Brake Conversions require special brake lines that fit your new disc conversion setup. Right Stuff offers "No Brainer" Brake Line Kits that include all components needed from your master cylinder back to your rear wheel cylinder or calipers. They include front brake line kit, front to rear line, rear axle lines & flex hose, & clip set.

See page 196 for your application

SKYLARK/GS REAR BRAKE CONVERSIONS

**STREET
SERIES**

REAR DISC BRAKE CONVERSION KITS

REAR CONVERSIONS INCLUDE:

- 11" Rotors
- Caliper Brackets & Spacers
- Weld-On Hose Brackets
- Flex Hoses
- Backing Plates (Exclusive), not for AFXRD78 or AFXRDM78
- New Loaded Caliper
- E-Brake Cables
- Hardware

Right Stuff disc conversions are the most complete kits in the industry at the right price. High quality components, professional packaging, and after-sale support by "hands-on" technicians create an unbeatable value. Consider one of our complete brake line packages for a carefree installation. See the next page to verify axle flange measurements for these kits.

NOTE:

FITS FACTORY
REAR ENDS
CALL FOR CUSTOM
APPLICATIONS

WORKS WITH 15" AND LARGER WHEELS

6-3/16" INSIDE ROTOR DIAMETER - 2.78" CENTER HOLE

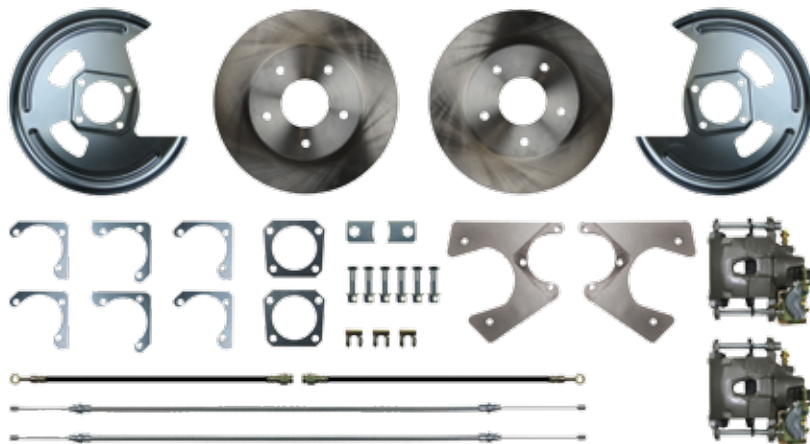

ATTENTION Before you order, be sure to measure the axle flange on your vehicle.

REAR KITS WITH E-BRAKE

AFXRD01 64-77 10 & 12 Bolt
AFXRD78 78-88 10 Bolt

REAR KITS WITHOUT E-BRAKE

AFXRDM1 64-77 10 & 12 Bolt
AFXRDM78 78-88 10 Bolt

REAR DISC BRAKE CONVERSION UPGRADES

**STREET
SERIES**

SHOW'N GO UPGRADE TRIM PACKAGES

These Rear Disc Conversion Kits include upgraded drilled slotted rotors with zinc plating, powder coated calipers in red or black, and braided stainless hoses.



REAR UPGRADE WITH E-BRAKE

AFXRD01S 64-77 10 & 12 Bolt - Black
AFXRD01Z 64-77 10 & 12 Bolt - Red
AFXRD78S 78-88 10 Bolt - Black
AFXRD78Z 78-88 10 Bolt - Red

REAR UPGRADE W/O E-BRAKE

AFXRDM1S 64-77 ... 10 & 12 Bolt - Black
AFXRDM1Z 64-77 ... 10 & 12 Bolt - Red
AFXRDM78S ... 78-88 ... 10 Bolt - Black
AFXRDM78Z ... 78-88 ... 10 Bolt - Red



SKYLARK/GS REAR +2 BRAKE CONVERSIONS

**STREET
SERIES**

REAR +2 DISC BRAKE CONVERSION KITS

REAR +2 CONVERSIONS INCLUDE:

- 11" Drilled-Slotted-Zinc Rear Rotors
- Black or Red Rear Powder Coated Calipers
- Braided Stainless Rear Hoses
- Brackets, Spacers, Hardware
- Weld-On Hose Brackets
- Backing Plates *TRSD Exclusive
- E-Brake Cables

+2 KITS ALSO INCLUDE

- Drilled-Slotted-Zinc Front Rotors
- Black or Red Powder Coated Front Calipers
- Braided Stainless Front Hoses

Right Stuff disc conversions are the most complete kits in the industry at the right price. High quality components, professional packaging, & after-sale support by "hands-on" technicians create an unbeatable value. Get a rear conversion & matching front upgrades with a single part number.



FRONT ROTORS
DRILLED & SLOTTED

NOTE:

FITS FACTORY
REAR ENDS
CALL FOR CUSTOM
APPLICATIONS

WORKS WITH 15" AND LARGER WHEELS

REAR DISC BRAKES + MATCHING FRONT UPGRADES
6-3/16" INSIDE ROTOR DIAMETER - 2.78" CENTER HOLE

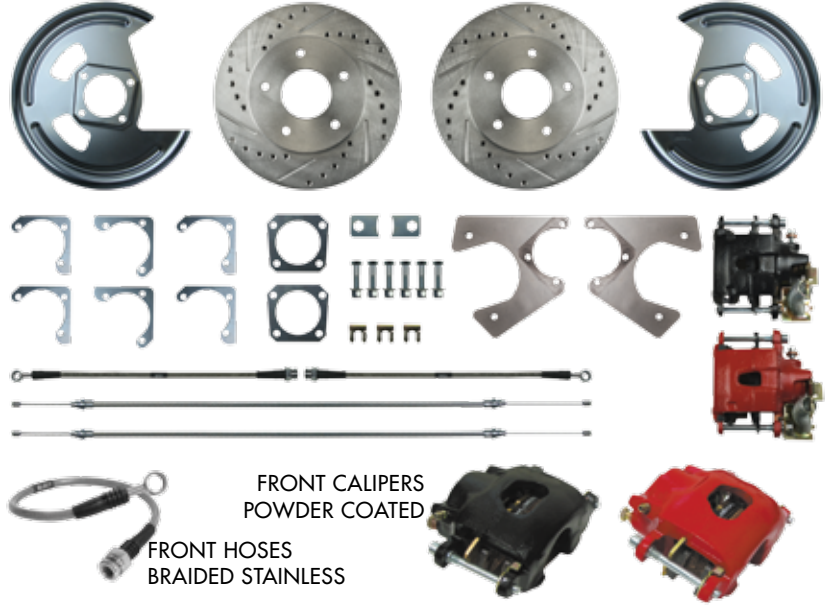

FRONT CALIPERS
POWDER COATED

FRONT HOSES
BRAIDED STAINLESS

REAR +2 KITS WITH E-BRAKE

- A69RD01S 69-72 Skylark/GS Black Calipers, Drilled/Slotted
- A69RD01Z 69-72 Skylark/GS Red Calipers, Drilled/Slotted
- A73RD01S 73-77 Skylark/GS Black Calipers, Drilled/Slotted
- A73RD01Z 73-77 Skylark/GS Red Calipers, Drilled/Slotted
- A78RD78S78..... Skylark/GS Black Calipers, Drilled/Slotted
- A78RD78Z78..... Skylark/GS Red Calipers, Drilled/Slotted
- A79RD78S 79-81 Skylark/GS Black Calipers, Drilled/Slotted
- A79RD78Z 79-81 Skylark/GS Red Calipers, Drilled/Slotted

- A82RD78S ..82-88.. Regal/GN/GNX Black Calipers, Drilled/Slotted
- A82RD78Z ..82-88.. Regal/GN/GNX Red Calipers, Drilled/Slotted

REAR +2 KITS WITHOUT E-BRAKE

- A69RDM1S..... 69-72 ... Skylark/GS Black Calipers, Drilled/Slotted
- A69RDM1Z 69-72 ... Skylark/GS Red Calipers, Drilled/Slotted
- A73RDM1S..... 73-77 ... Skylark/GS Black Calipers, Drilled/Slotted
- A73RDM1Z 73-77 ... Skylark/GS Red Calipers, Drilled/Slotted
- A78RDM78S.....78 Skylark/GS Black Calipers, Drilled/Slotted
- A78RDM78Z78 Skylark/GS Red Calipers, Drilled/Slotted
- A79RDM78S... 79-81 ... Skylark/GS Black Calipers, Drilled/Slotted
- A79RDM78Z .. 79-81 ... Skylark/GS Red Calipers, Drilled/Slotted

- A82RDM78S.. 82-88 ..Regal/GN/GNX Black Calipers, Drilled/Slotted
- A82RDM78Z.. 82-88 ..Regal/GN/GNX Red Calipers, Drilled/Slotted

AXLE FLANGE DIAGRAMS

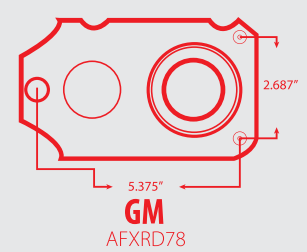
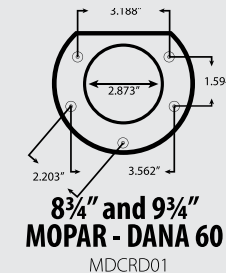
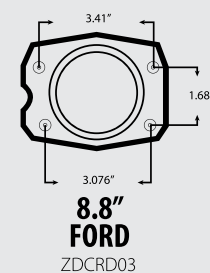
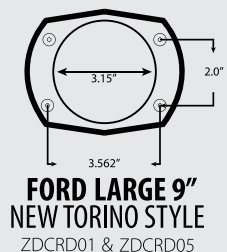
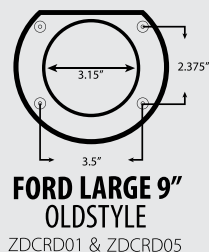
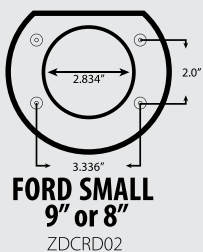
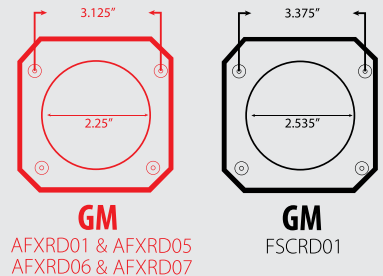
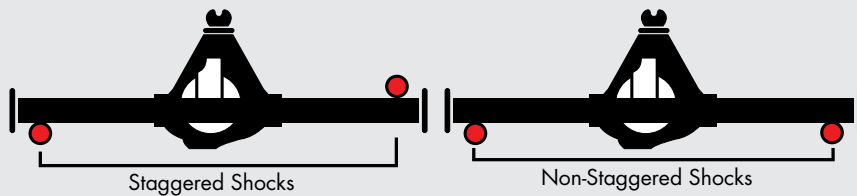

SKYLARK/GS EZ FIT BRAKE CONVERSIONS



BRAKE•KITS

Fits stock 14" wheel. Bolts to stock drum or disc brake spindles. Minimal offset for better fenderwell clearance. Proprietary rotor.

EZ FIT BRAKE CONVERSION KITS

HALF THE INSTALL TIME
KEEP YOUR FACTORY
14" WHEELS

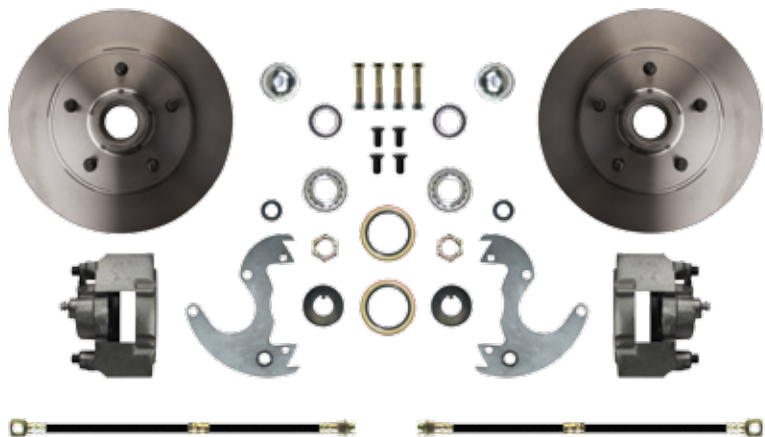

FRONT AT-THE WHEEL KITS

Bolts to your stock drum or disc brake spindles.

Available with standard stock-style rotors or upgraded drilled, slotted & zinc rotors.

FRONT 14" - STANDARD ROTORS

AFXWK1464-72..... Front At-the-Wheel Disc Conversion Kit
 AFXSD1464-72..... Front Manual Disc Conversion Package
 AFXDC1464-72..... Front Power Disc Conversion Package

REAR 14" - STANDARD ROTORS

AFXRD1464-77..... Rear Kit, Non-Staggered



LOOKING FOR A DIFFERENT BOOSTER + MASTER CYLINDER IN YOUR KIT?

Simply purchase an At-The-Wheel Kit above along with any Booster + Master combo on page 177.



EZ FIT FRONT CONVERSIONS INCLUDE:

- 10" Rotors with Organic Pads
- New Calipers & Brackets
- Banjo Bolts & Copper Washers
- Dust Caps, Castle Nuts & Pins
- Brake Switch Pigtail
- Master Cylinder (Power/Manual Kits)
- Timken Bearings
- Flex Hoses & Kit
- Grease Seals
- Steering Arm Bolts
- Combination Valve
- 9" Booster (Power)

EZ FIT REAR CONVERSIONS INCLUDE:

- Fits 14" wheels
- Uses proprietary rotor
- Built in e-brake (No cables included)



Packages include At-the-Wheel Disc Conversion Kits & Master Cylinder with Valve (Manual) or Master Cylinder with Booster and Valve (Power).

POWER PACKAGE



MANUAL PACKAGE

FRONT 14" - UPGRADE ROTORS

AFXWK14A ..64-72..... Front At-the-Wheel Disc Conversion Kit
 AFXSD14A....64-72..... Front Manual Disc Conversion Package
 AFXDC14A...64-72..... Front Power Disc Conversion Package

REAR 14" - UPGRADE ROTORS

AFXRD14A....64-77..... Rear Kit, Non-Staggered



Disc Brake Conversions require special brake lines that fit your new disc conversion setup. Right Stuff offers "No Brainer" Brake Line Kits that include all components needed from your master cylinder back to your rear wheel cylinder or calipers. They include front brake line kit, front to rear line, rear axle lines & flex hose, & clip set.

See page 196 for your application

SKYLARK/GS PERFORMANCE SERIES CONVERSIONS



COMPLETE DISC BRAKE CONVERSION KITS



U.S.A. Made
TIMKEN Bearings

Right Stuff Performance Series disc conversions are the most complete kits in the industry at the right price. Designed for the performance street machine with high quality components, professional packaging, and after-sale support by "hands-on" technicians and many DIY videos at rightstuff create an unbeatable value.

Kits are available as a **Disc Brake Upgrade** that bolts to stock front disc brake spindles, or as an **At-The-Wheel Kit** that includes everything for a front disc brake conversion, and as a **Complete Conversion Kit** which includes everything in the At-The-Wheel Kit with the addition of the master cylinder, booster and prop valve (Power or Manual).

AT-THE-WHEEL CONVERSION KITS INCLUDE:

- 11" Drilled & Slotted Rotors
- Wilwood Dual Piston Calipers
- Caliper Brackets
- Backing Plates
- Timken Bearings
- Castle Nuts & Pins
- Dust Caps
- Forged Spindles
- Organic Pads
- Washers
- Grease Seals
- Spindle Gaskets
- Steering Arm Bolts
- Hardware

COMPLETE CONVERSION KITS ALSO INCLUDE

- Master Cylinder - Chrome or Standard Finish
- Flex Hoses & Clips
- Valve Bracket & Hardware
- Banjo Bolts & Copper Washers
- Combination Valve
- Brake Switch Pigtail
- Pedal Rod Extension

WORKS WITH 15" AND LARGER WHEELS

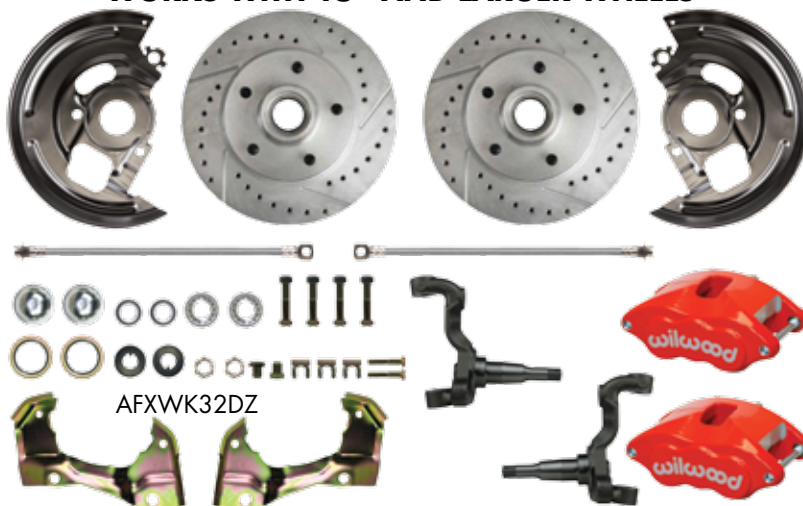

FRONT AT-THE-WHEEL KITS From

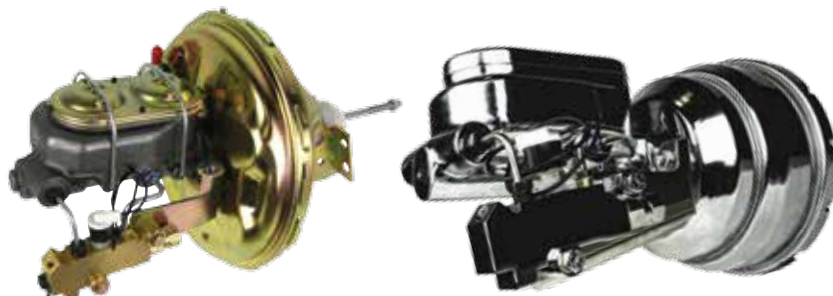

STANDARD PACKAGE

CHROME PACKAGE

Packages include At-the-Wheel Disc Conversion Kits and Chrome or Standard Finish Master Cylinder with Booster and Valve (Power).

AT-THE-WHEEL FRONT DISC KITS

- AFXWK32S..... 64-72... At-the-Wheel Stock Height - Black Wilwood
- AFXWK32Z 64-72... At-the-Wheel Stock Height - Red Wilwood
- AFXWK32DS ... 64-72... At-the-Wheel 2" Drop - Black Wilwood
- AFXWK32DZ ... 64-72... At-the-Wheel 2" Drop - Red Wilwood

STOCK HEIGHT FRONT KITS

- AFXDC32S..... 64-72... Standard Booster/Master - Black Wilwood
- AFXDC32Z 64-72... Standard Booster/Master - Red Wilwood
- AFXDC32SX..... 64-72... Chrome Booster/Master - Black Wilwood
- AFXDC32ZX..... 64-72... Chrome Booster/Master - Red Wilwood

2" DROP FRONT KITS

- AFXDC32DS 64-72... Standard Booster/Master - Black Wilwood
- AFXDC32DZ 64-72... Standard Booster/Master - Red Wilwood
- AFXDC32DSX... 64-72... Chrome Booster/Master - Black Wilwood
- AFXDC32DZX .. 64-72... Chrome Booster/Master - Red Wilwood



DISC BRAKE UPGRADE KITS INCLUDE (Kit is Designed to Bolt to Stock Disc Brake Spindles)

- Wilwood 2-Piston Aluminum Calipers
- Cross-Drilled & Slotted Zinc Plated Rotors
- Braided Stainless Hoses
- Organic Brake Pads

DISC BRAKE UPGRADE KITS

- RCP69S 64-72 Black 2-Piston Wilwood Calipers
- RCP69Z 64-72 Red 2-Piston Wilwood Calipers

SKYLARK/GS SIGNATURE SERIES CONVERSIONS



DISC BRAKE CONVERSION KITS

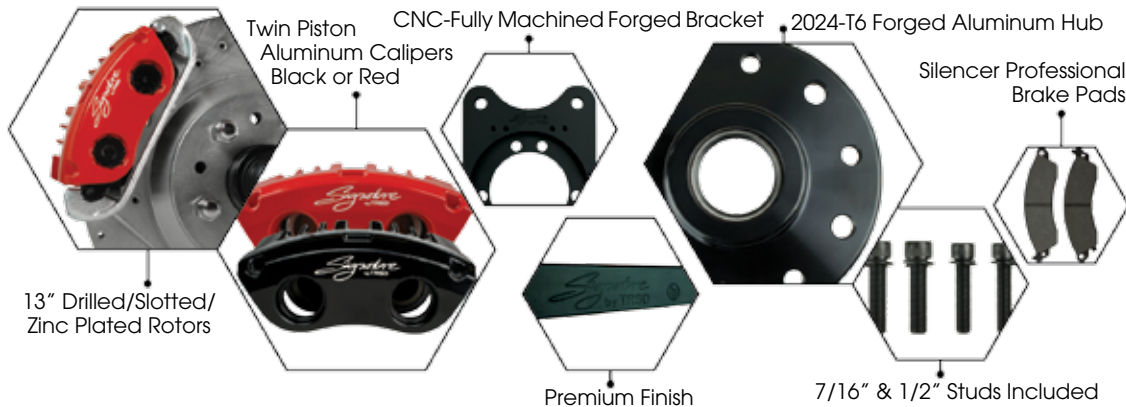

DESIGNED FOR 17\"/>

Bold looks define the Signature Series line of brake kits. Large diameter zinc plated rotors, powder coated calipers, fully machined caliper brackets, & braided stainless brake hoses. Only premium quality components make the grade. We back every kit with industry leading technical support. Signature Series kits are amazing brakes at a great price. Add a No Brainer Brake Line Kit for a true bolt-on install.

SIGNATURE SERIES FRONT KIT

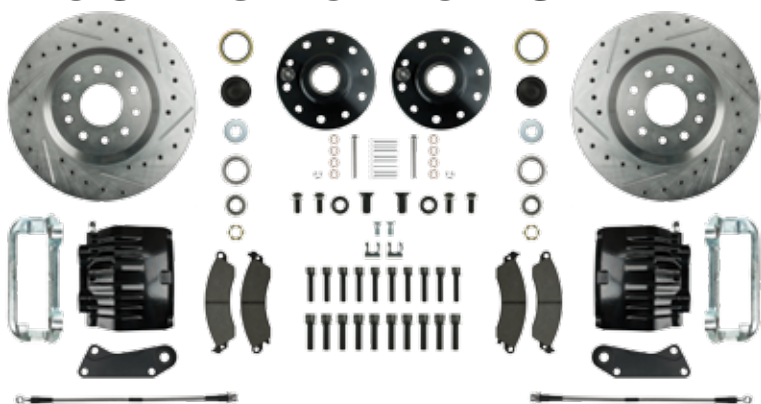

U.S.A. Made **TIMKEN** Bearings



STOCK HEIGHT FRONT KITS

Uses existing drum or disc brake spindles

- AFXWK31CS 64-72..... At-the-Wheel Kit - Black Calipers
- AFXWK31CZ 64-72..... At-the-Wheel Kit - Red Calipers
- AFXSD31CS 64-72..... Manual Kit - Black Calipers
- AFXSD31CZ 64-72..... Manual Kit - Red Calipers
- AFXDC31CS 64-72..... Power Kit - Black Calipers
- AFXDC31CZ 64-72..... Power Kit - Red Calipers

STOCK HEIGHT 4-WHEEL KITS

Stock Height - Non-Staggered Shocks

- AFXWK51CS 64-72..... At-the-Wheel Kit - Black Calipers
- AFXWK51CZ 64-72..... At-the-Wheel Kit - Red Calipers
- AFXSD51CS 64-72..... Manual Kit - Black Calipers
- AFXSD51CZ 64-72..... Manual Kit - Red Calipers
- AFXDC51CS 64-72..... Power Kit - Black Calipers
- AFXDC51CZ 64-72..... Power Kit - Red Calipers

2\"/>

Includes new 2\"/>

- AFXWK31DS 64-72..... At-the-Wheel Kit - Black Calipers
- AFXWK31DZ 64-72..... At-the-Wheel Kit - Red Calipers
- AFXSD31DS 64-72..... Manual Kit - Black Calipers
- AFXSD31DZ 64-72..... Manual Kit - Red Calipers
- AFXDC31DS 64-72..... Power Kit - Black Calipers
- AFXDC31DZ 64-72..... Power Kit - Red Calipers

2\"/>

2\"/>

- AFXWK51DS 64-72..... At-the-Wheel Kit - Black Calipers
- AFXWK51DZ 64-72..... At-the-Wheel Kit - Red Calipers
- AFXSD51DS 64-72..... Manual Kit - Black Calipers
- AFXSD51DZ 64-72..... Manual Kit - Red Calipers
- AFXDC51DS 64-72..... Power Kit - Black Calipers
- AFXDC51DZ 64-72..... Power Kit - Red Calipers



Disc Brake Conversions require special brake lines that fit your new disc conversion setup. Right Stuff offers "No Brainer" Brake Line Kits that include all components needed from your master cylinder back to your rear wheel cylinder or calipers. They include front brake line kit, front to rear line, rear axle lines & flex hose, & clip set.

See page 196 for your application

SKYLARK/GS SIGNATURE SERIES CONVERSIONS

X-TRIM DISC BRAKE CONVERSION UPGRADES



Start turning heads with a show finished upper assembly. Manual kits get a chrome plated master cylinder and combination valve with bracket. Power kits also include an 8" dual chrome booster.



X-TRIM UPGRADE FRONT KITS

Stock Height uses Existing Spindles

- AFXSD31CSX.... 64-72 ... Manual Kit - Black Calipers - Stock Height
- AFXSD31CZX.... 64-72 ... Manual Kit - Red Calipers - Stock Height
- AFXDC31CSX ... 64-72 ... Power Kit - Black Calipers - Stock Height
- AFXDC31CZX ... 64-72 ... Power Kit - Red Calipers - Stock Height

2" Drop Includes New Spindles

- AFXSD31DSX..... 64-72.....Manual Kit - Black Calipers - 2" Drop
- AFXSD31DZX..... 64-72.....Manual Kit - Red Calipers - 2" Drop
- AFXDC31DSX..... 64-72.....Power Kit - Black Calipers - 2" Drop
- AFXDC31DZX 64-72.....Power Kit - Red Calipers - 2" Drop

X-TRIM UPGRADE 4-WHEEL KITS

Non-Staggered Shocks

- AFXSD51CSX....64-72.... Manual Kit - Black Calipers - Stock Height
- AFXSD51CZX....64-72.... Manual Kit - Red Calipers - Stock Height
- AFXDC51CSX ...64-72.... Power Kit - Black Calipers - Stock Height
- AFXDC51CZX ...64-72.... Power Kit - Red Calipers - Stock Height

2" Drop Includes New Spindles

- AFXSD51DSX....64-72.... Manual Kit - Black Calipers - 2" Drop
- AFXSD51DZX....64-72.... Manual Kit - Red Calipers - 2" Drop
- AFXDC51DSX....64-72.... Power Kit - Black Calipers - 2" Drop
- AFXDC51DZX ...64-72.... Power Kit - Red Calipers - 2" Drop



REAR DISC BRAKE CONVERSION KITS

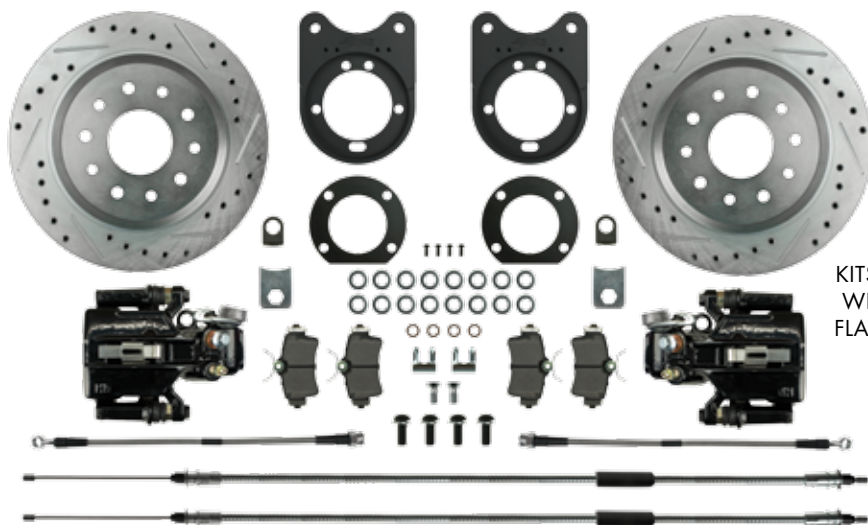

KITS FIT AXLES WITH 3-1/8" FLANGE ONLY

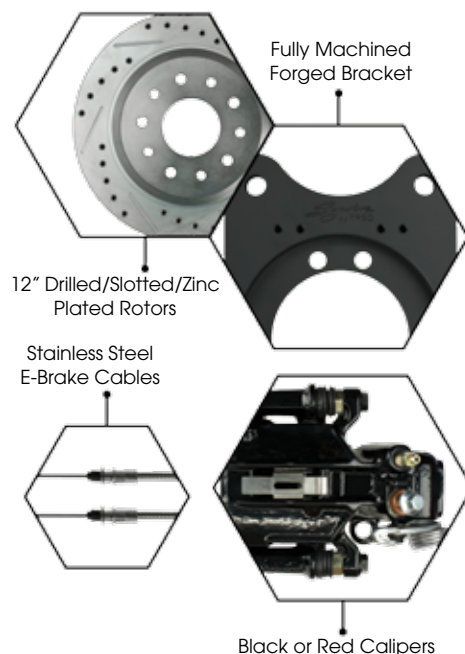

REAR DISC CONVERSION KITS

AFXRD31S 64-77 Rear Disc Conversion - Black

AFXRD31Z 64-77 Rear Disc Conversion - Red





No Brainer BRAKE LINE KITS FOR DISC CONVERSIONS

When you add disc brakes to your car you are using a new valve that has different size ports pointing in different directions. Even if your lines are brand new or great originals, you are going to have issues trying to use them. Our "No Brainer" Brake Line Kit fixes all these issues from your master cylinder all the way back to your rear wheel cylinders or rear calipers. We give you all the lines to complete the installation. We also include the rear flex hose and a full clip set to install your lines. Extremely discounted prices and great instructions make this kit a No Brainer.

SIMPLIFY YOUR DISC BRAKE CONVERSION INSTALLATION WITH ALL OF THE BRAKE LINES YOU WILL NEED.

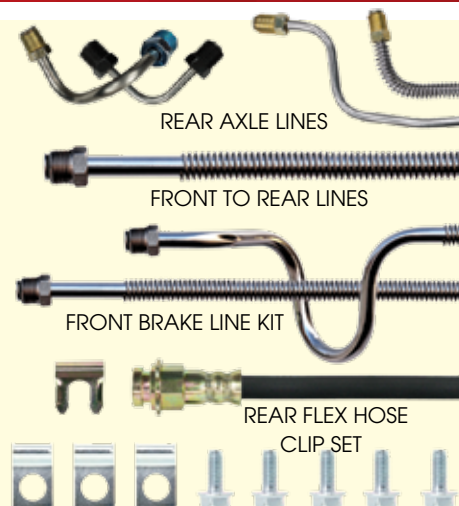

MANUAL - NO VACUUM BOOSTER

FRONT DISC/REAR DRUM LINES

AOM64H2 64-65 OE Steel, Hardtop
ASM64H2 64-65 Stainless, Hardtop
AOM64C2 64-65 OE Steel, Convertible
ASM64C2 64-65 Stainless, Convertible
AOM66H2 66 OE Steel, Hardtop
ASM66H2 66 Stainless, Hardtop
AOM66C2 66 OE Steel, Convertible
ASM66C2 66 Stainless, Convertible
AOM67H2 67 OE Steel, Hardtop
ASM67H2 67 Stainless, Hardtop
AOM67C2 67 OE Steel, Convertible
ASM67C2 67 Stainless, Convertible
AOM68H2 68 OE Steel, Hardtop
ASM68H2 68 Stainless, Hardtop
AOM68C2 68 OE Steel, Convertible
ASM68C2 68 Stainless, Convertible
AOM69H2 69-72 OE Steel, Hardtop
ASM69H2 69-72 Stainless, Hardtop
AOM69C2 69-72 OE Steel, Convertible
ASM69C2 69-72 Stainless, Convertible

POWER - WITH VACUUM BOOSTER

FRONT DISC/REAR DRUM LINES

AOP64H2 64-65 OE Steel, Hardtop
ASP64H2 64-65 Stainless, Hardtop
AOP64C2 64-65 OE Steel, Convertible
ASP64C2 64-65 Stainless, Convertible
AOP66H2 66 OE Steel, Hardtop
ASP66H2 66 Stainless, Hardtop
AOP66C2 66 OE Steel, Convertible
ASP66C2 66 Stainless, Convertible
AOP67H2 67 OE Steel, Hardtop
ASP67H2 67 Stainless, Hardtop
AOP67C2 67 OE Steel, Convertible
ASP67C2 67 Stainless, Convertible
AOP68H2 68 OE Steel, Hardtop
ASP68H2 68 Stainless, Hardtop
AOP68C2 68 OE Steel, Convertible
ASP68C2 68 Stainless, Convertible
AOP69H2 69-72 OE Steel, Hardtop
ASP69H2 69-72 Stainless, Hardtop
AOP69C2 69-72 OE Steel, Convertible
ASP69C2 69-72 Stainless, Convertible

4-WHEEL DISC LINES

AOM64H4 64-65 OE Steel, Hardtop
ASM64H4 64-65 Stainless, Hardtop
AOM64C4 64-65 OE Steel, Convertible
ASM64C4 64-65 Stainless, Convertible
AOM66H4 66 OE Steel, Hardtop
ASM66H4 66 Stainless, Hardtop
AOM66C4 66 OE Steel, Convertible
ASM66C4 66 Stainless, Convertible
AOM67H4 67 OE Steel, Hardtop
ASM67H4 67 Stainless, Hardtop
AOM67C4 67 OE Steel, Hardtop
ASM67C4 67 Stainless, Convertible
AOM68H4 68 OE Steel, Hardtop
ASM68H4 68 Stainless, Hardtop
AOM68C4 68 OE Steel, Convertible
ASM68C4 68 Stainless, Convertible
AOM69H4 69-72 OE Street, Hardtop
ASM69H4 69-72 Stainless, Hardtop
AOM69C4 69-72 OE Steel, Convertible
ASM69C4 69-72 Stainless, Convertible

4-WHEEL DISC LINES

AOP64H4 64-65 OE Steel, Hardtop
ASP64H4 64-65 Stainless, Hardtop
AOP64C4 64-65 OE Steel, Convertible
ASP64C4 64-65 Stainless, Convertible
AOP66H4 66 OE Steel, Hardtop
ASP66H4 66 Stainless, Hardtop
AOP66C4 66 OE Steel, Convertible
ASP66C4 66 Stainless, Convertible
AOP67H4 67 OE Steel, Hardtop
ASP67H4 67 Stainless, Hardtop
AOP67C4 67 OE Steel, Convertible
ASP67C4 67 Stainless, Convertible
AOP68H4 68 OE Steel, Hardtop
ASP68H4 68 Stainless, Hardtop
AOP68C4 68 OE Steel, Convertible
ASP68C4 68 Stainless, Convertible
AOP69H4 69-72 OE Steel, Hardtop
ASP69H4 69-72 Stainless, Hardtop
AOP69C4 69-72 OE Steel, Convertible
ASP69C4 69-72 Stainless, Convertible

FRONT BRAKE LINE KITS

Front brake line kits consist of all brake lines under the hood. This includes the master cylinder to the distribution, combination or metering valve. The left and right front lines that run to the front flex hoses are also included. Call for individual component pricing. These line kits are for vehicles with factory brake systems.

ADD "S" TO PART NUMBER FOR STAINLESS STEEL

WKT410141-42....	Standard Drum.....	3 Pcs.
WKT4901 49	Standard Drum.....	3 Pcs.
WKT5701 57	Power Drum.....	4 Pcs.
WKT5801 58	Manual Drum.....	3 Pcs.
WKT5901 59	Manual Drum.....	3 Pcs.
WKT6301 63	Manual Drum.....	3 Pcs.
WKT6601 66	Power Drum.....	3 Pcs.
WKT760172-76....	Power Disc, Eldorado	4 Pcs.

FRONT TO REAR LINE KITS

Front to rear brake lines go from the distribution, combination or metering valve along the length of the vehicle to the rear flex hose. Lines are manufactured in 1 or 2 pieces based on factory specifications.

ADD "S" TO PART NUMBER FOR STAINLESS STEEL

WIN4101 41	Manual Drum, 4 Door
WIN4201 42	Manual Drum
WIN4901 49	Manual Drum
WIN5701 57	Model 62, 129" WB
WIN5901 59	Manual Drum
WIN6301 63	Manual Drum
WIN6601 66	Power Drum
WIN760172-76....	Power Disc, Eldorado Convertible

REAR FLEX BRAKE HOSES

Rear flex hoses carry brake fluid between the body of the car and the rear. Hoses are available in O.E. rubber and braided stainless steel. 'T' blocks are attached whenever factory correct. All of our hoses are D.O.T. approved. Prices are per hose.

FH1072-76.....	El Dorado - OE Steel
FH10S72-76.....	El Dorado - Stainless

TRANSMISSION COOLER LINES

Transmission cooler lines are sold as pairs. Be sure to verify the type of transmission in your project before ordering. Intended to work only with factory motor, transmission, and radiator combinations. If your system is not 100% stock, call us for options.

WTC5801 58	365, Turbo Hydromatic - OE Steel
WTC5801S	... 58	365, Turbo Hydromatic - Stainless
WTC6601 66	TH 400 - OE Steel
WTC6601S	... 66	TH 400 - Stainless

REAR AXLE BRAKE LINES

Rear axle brake lines include a pair of lines that run across the rear axle housing. These lines connect the wheel cylinders or calipers to the flex hose in the middle of the rear end. These lines work with original housings that use factory brakes. Modifications such as rear disc brakes or narrowed rear ends will likely require special lines. Call for more information.

ADD "S" TO PART NUMBER FOR STAINLESS STEEL

WRA410141-42....	All Cars
WRA4901 49	All Cars
WRA5701 57	All Cars
WRA5902 59	All Cars
WRA6301 63	All Cars
WRA6601 66	All Cars
WRA760172-76....	Eldorado

FUEL PUMP TO CARB LINES

Fuel pump to carburetor lines connect the fuel pump to the carburetor. Brass blocks and fittings are included as noted. Lines are intended to work only with factory pump, motor, intake & carburetor combinations.

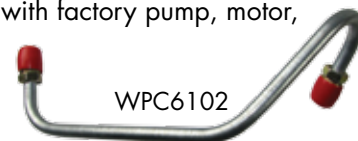

ADD "S" TO PART NUMBER FOR STAINLESS STEEL

WPC4101 41	346, 5/16"
WPC5001	... 50-51 ...	Carter 2 BBL Pump to Glass Filter
WPC5203	... 52-53 ...	Rochester 4 BBL carb to Glass Filter
WPC5406	... 54-56 ...	Rochester 4 BBL Pump to glass filter
WPC5408	... 54-56 ...	Carter 4 BBL Pump to Glass Filter
WPC5501 55	Rochester Dual 4 BBL Filter to Carb
WPC5557	... 55-57 ...	El Dorado 2-Piece.
WPC5701 57	Carter AFB 4 BBL
WPC5801 58	Carter AFB 4 BBL
WPC5803 58	Tri-Power Center to Rear
WPC5804 58	Tri-Power
WPC5806	... 58-62 ...	Carter 4 BBL Carb to Glass Filter
WPC5807 58	Rochester with AC, Carb to Glass Filter
WPC5901 59	Tri-Power 6-Piece.
WPC5906	... 61-62 ...	Carter 4 BBL Carb to glass filter
WPC5908	... 59-60 ...	Rochester 4 BBL w/AC Carb to Filter
WPC6102	... 61-62 ...	Rochester 4 BBL
WPC6301	... 63-66 ...	Carter AFB Carb to Glass Filter
WPC6304	... 63-64 ...	Pump to Glass Filter, All
WPC6501 65	Carter/Rochester Pump to Filter
WPC6601 66	472 2-Piece
WPC6701 67	Quadrajct
WPC6901	... 69-72 ...	5/16"

OIL SUPPLY LINES

WOL4101 41	Oil Supply Line - OE Steel
WOL4101S	... 41	Oil Supply Line - Stainless

CADILLAC & CUTLASS-442 LINES

THERMAL CHOKE LINES

Thermal choke lines carry heat from the exhaust system to the choke coil on the carburetor. Some applications route thru the intake manifold on their way to the carburetor.



ADD "S" TO PART NUMBER FOR STAINLESS STEEL

- WCH5001502 BBL Stromberg
- WCH5002502 BBL Carter
- WCH5201 ... 52-55 ...4 BBL Carter Choke Tube
- WCH5501 ... 54-55 ...4 BBL Rochester Choke Tube
- WCH560156Carter 4 BBL
- WCH560256Rochester 4 BBL

MAIN FUEL LINES

Main lines carry fuel from the tank in the rear of the car to the fuel pump or rail in the front. They are available in 3/8" and 5/16" tubing based on factory specifications. Multiple piece sets are noted. Call for 1/2" lines.

ADD "S" TO PART NUMBER FOR STAINLESS STEEL

- WGL4101 415/16" Main Fuel Line, 4 Door
- WGL5702 575/16", Model 62, 129" WB
- WGL6301 635/16" Main Fuel Line
- WGL6601 665/16" Main Fuel Line
- WGL7201 723/8" Main Line 2-Piece.

RETURN FUEL LINES

Return lines carry excess fuel from fuel pump or fuel filter back to the tank. Not all vehicles were equipped with a return line. They are typically made of 1/4" diameter tubing.

ADD "S" TO PART NUMBER FOR STAINLESS STEEL

- WGL6602 661/4" Return Line 2-Piece
- WGL7202 721/4" Return Line 2-Piece

VACUUM LINES

ADD "S" TO PART NUMBER FOR STAINLESS STEEL

- WDV4101 41 Distributor Vacuum Line
- WPV4101 41 5/16" Fuel Pump to Intake Line
- WPV4102 41 1/4" Carb to Bellhousing Area
- WVV4101 ... 41 Wiper Motor Vacuum Line
- WDV5206 ... 52-56 ... 4 BBL Distributor Vacuum Line
- WVC5401 ... 54-58 ... Vacuum Intake to Dash
- WBV5406 ... 54-56 ... 4 BBL Power Brake Vacuum Tube
- WVC5601 56 El Dorado Vacuum Canister Tube
- WDV5501 55 Rochester Dual 4 BBL Dist. Vacuum
- WCV5701 57 El Dorado Vacuum Canister Tube
- WBV5701 57 El Dorado Booster Vac. Tube 4 BBL
- WDV5701 ... 57-58 ... Carter AFB Distributor Vacuum
- WDV6201 62 Rochester AFB Distributor Vacuum
- WTV6405 ... 64-65 ... TH 400 Transmission Vacuum Line
- WTV6601 66 Transmission Vacuum Line
- WTV6701 67 TH 400
- WTV6807 ... 68-73 ... TH 400

TRANSMISSION COOLER LINES

Transmission cooler lines are sold as pairs. Be sure to verify the type of transmission in your project before ordering. These lines are intended to work only with factory motor, transmission, and radiator combinations.

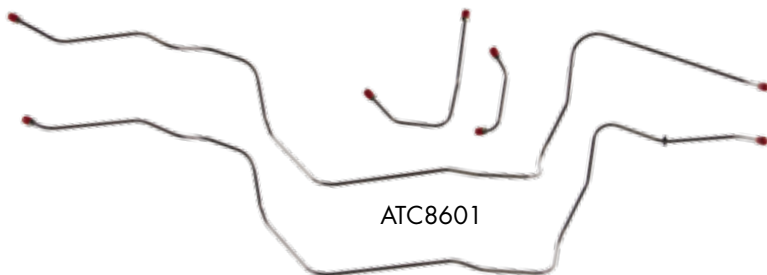

ADD "S" TO PART NUMBER FOR STAINLESS STEEL

- ATC6301 63 Starfire
- ATC6602 66-67 Jet-Away or T-400
- ATC6803 68-72 with T-350 or 400
- ATC70AX 70 442 with Aux. Cooler
- ATC7503 73-77 Hurst Olds with T-350
- ATC7901 78-79 200 (Metric)
- ATC8501 85 307 ci
- ATC8601 86-87 All Cars

VACUUM LINES

ADD "S" TO PART NUMBER FOR STAINLESS STEEL

- ATV6602 66T-400 & T-350, Trans. Vacuum
- ATV6701 67T-400, Trans. Vacuum excluding 442
- ATV6702 67T-400, Trans. Vacuum 442 only
- ATV6803 68-72T-400, Trans. Vacuum
- ATV6806 68-72T-350, Trans. Vacuum
- ABV6901 69400 ci, Brake Vacuum
- ABV7101 71455 ci, Brake Vacuum
- ATV7503 73-77T-350, Trans. Vacuum

POWER STEERING LINES

Power steering lines can be either pressure or return feeds in a power steering system.



- APH6501 65-67SS 396 External Power Steering Hose
- APH7001 70-71SS 396/454 Power Steering Hose
- APS7301 73-75Low Pressure Line
- APH6001 AllPower Steering Return Hose Kit

FRONT BRAKE LINE KITS

Front brake line kits consist of all brake lines under the hood. This includes the master cylinder to the distribution, combination or metering valve. The left and right front lines that run to the front flex hoses are also included. Call for individual component pricing. These line kits are for vehicles with factory brake systems.

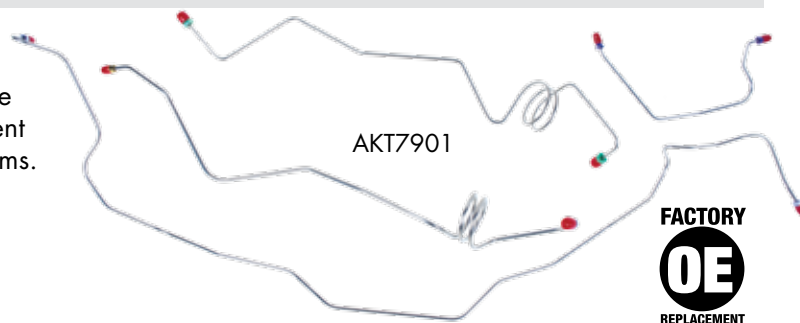

ADD "S" TO PART NUMBER FOR STAINLESS STEEL

AKT6102.....62.....Manual Drum.....	3 Pcs.
AKT6301.....63.....Standard Drum.....	3 Pcs.
AKT6501.....65.....Manual Drum.....	3 Pcs.
AKT6604.....66.....Manual Drum.....	3 Pcs.
AKT6605.....66.....Power Drum.....	3 Pcs.
AKT6711.....67.....Standard Drum.....	4 Pcs.
AKT6712.....67.....Power Drum, Automatic.....	4 Pcs.
AKT6713.....67.....Power Drum, 4 Speed.....	4 Pcs.
AKT6714.....67.....Power Disc.....	5 Pcs.
AKT6803.. 68-69... Power Disc.....	5 Pcs.

AKT6801.. 68-72 ... Std. Drum, with Wheel Lines
AKT6802.. 68-72 ... Power Drum, with Wheel Lines
AKT7003.....70.....Power Disc
AKT7004.....70.....Manual Disc
AKT7103.. 71-72 ... Power Disc
AKT7104.. 71-72 ... Manual Disc
AKT7503.. 73-77 ... Power Disc
AKT7901.. 78-87 ... Power Disc

FRONT TO REAR BRAKE LINES

Front to rear brake lines go from the distribution, combination or metering valve along the length of the vehicle to the rear flex hose. Lines are manufactured in 1 or 2 pieces based on factory specifications.

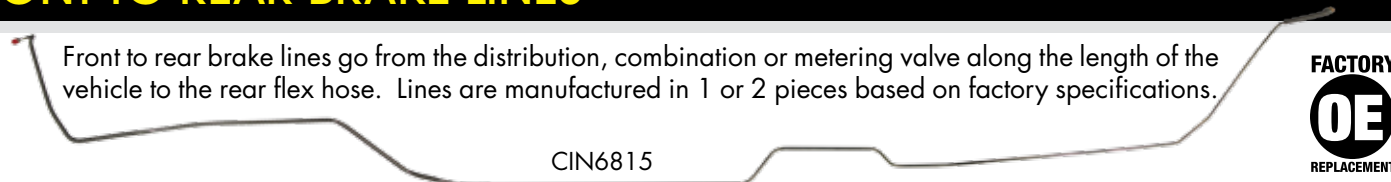

ADD "S" TO PART NUMBER FOR STAINLESS STEEL

AIN6201..... 62-63.....Hardtop
CIN6402..... 64-65.....Convertible
CIN6503..... 64-65.....Hardtop
CIN6605..... 66.....Hardtop
CIN6606..... 66.....Convertible
AIN6301..... 63.....Hardtop
AIN6701..... 67.....Hardtop, Automatic
AIN6702..... 67.....Convertible
AIN6707..... 67.....Hardtop, 4 Speed
CIN6801..... 68.....Hardtop

CIN6802..... 68.....Convertible
CIN6815..... 69.....Hardtop
CIN6816..... 69.....Convertible
CIN7021..... 70.....HT, Disc Only, Except 442 - See CIN7131, 2-Piece.
CIN7022..... 70.....Convertible, Disc Only, Except 442 - See CIN7132, 2-Piece
CIN7131..... 71-72.....HT, Also 70 442
CIN7132..... 71-72.....Convertible, Also 70 442
AIN7501..... 73-77.....Disc
AIN7901..... 78-87.....Cutlass Power Disc

REAR AXLE LINE KITS

Rear axle brake lines include a pair of lines that run across the rear axle housing. These lines connect the wheel cylinders or calipers to the flex hose in the middle of the rear end. These lines work with original housings that use factory brakes. Modifications such as rear disc brakes or narrowed rear ends will likely require special lines. Call for more information.

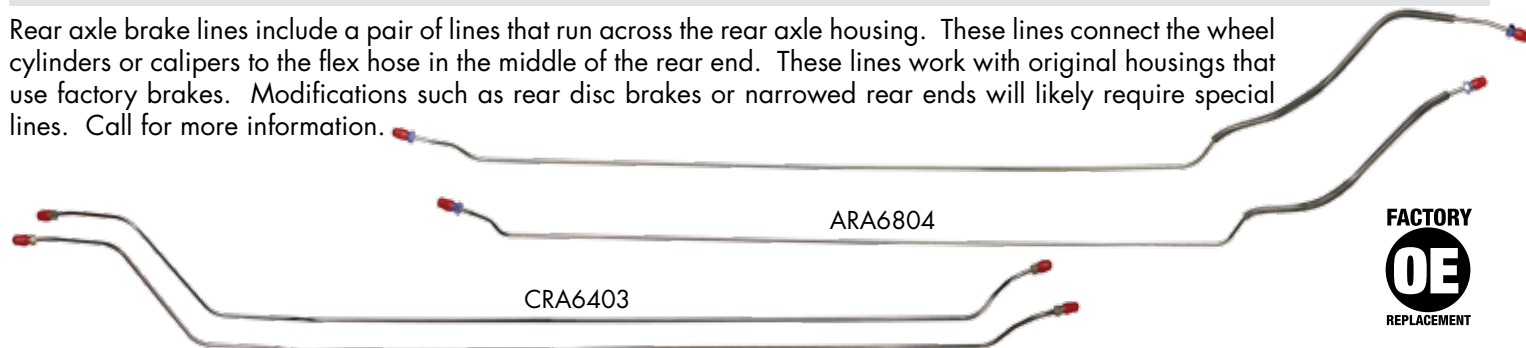

ADD "S" TO PART NUMBER FOR STAINLESS STEEL

ARA6102..... 62..... All Cars.....	2 Pcs.
ARA6301..... 63..... Starfire.....	2 Pcs.
CRA6403..... 64-65..... All Cars.....	2 Pcs.
ARA6603..... 66..... All Cars.....	2 Pcs.

ARA6702..... 67..... All Cars.....	2 Pcs.
ARA6804..... 68-72..... All Cars.....	2 Pcs.
ARA7501..... 73-77..... All Cars.....	2 Pcs.
ARA7901..... 78-87..... Cutlass.....	2 Pcs.
ARA8602..... 86..... Cutlass.....	2 Pcs.

CUTLASS - 442 BRAKE LINES

FRONT FLEX BRAKE HOSES

Front flex hoses provide a flexible connection from the body or frame to the front calipers or wheel cylinders as they move during suspension travel. Choose between O.E. rubber or braided stainless steel. All of our hoses are D.O.T. approved. Hoses are priced individually.



ADD "S" TO PART NUMBER FOR STAINLESS STEEL

- FH14..... 64-67 Drum
- FH26.....67 Disc
- FH21.....68 Disc
- FH21..... 68-72 Drum
- FH20..... 69-71 Disc
- FH24.....72 Disc
- FH161..... 75-76 Disc
- FH08.....77 Disc
- FH189.....78 Disc

REAR FLEX BRAKE HOSES

Rear flex hoses carry brake fluid between the body of the car and the rear. Hoses are available in O.E. rubber and braided stainless steel. 'T' blocks are attached whenever factory correct. All of our hoses are D.O.T. approved. Prices are per hose.



ADD "S" TO PART NUMBER FOR STAINLESS STEEL

- FH17..... 64-65 All
- FH28..... 66-67 All
- FH25.....68 All
- FH06..... 69-71 All
- FH15.....72 All

O.M. S.S

FLEX HOSES BRACKETS

These brackets and hardware are used to secure flex hoses to various parts of the vehicle. Front brackets are sold in pairs.



- RSBB01 64-68.....Rear Hose Brass 'T' Block (excl. 66-67)
- RSBK10 64-68.....Rear Hose Bracket, Used with Screw On Block
- RSBK66 684 Piston Inlet Line Brackets (pr)
- RSBK70 68-72.....Front Hose Brackets, Disc Only (pr)
- RSBK12 68-72.....12 Bolt Rear Hose Bracket
- BB6901 69-72.....Single Piston
- FHC01 AllCorrect Gold Cadmium Plated C Clips

200

DISC CALIPER BRAKE LINES

Front disc caliper lines connect the front flex hoses to the calipers. They were typically used on 4 piston calipers in the late 1960's. Several fitting sizes were available from the factory. Please verify fitting sizes before ordering as rebuilt calipers may not match the originals.

ADD "S" TO PART NUMBER FOR STAINLESS STEEL

- AFC670367 Power Disc
- AFC680168 3/8" x 3/8"
- AFC680268 1/2" Right, 7/16" Left

BRAKE LINE CLIPS

Brake line clip sets contain all the clips needed to fasten the brake tubes to the frame or body of the car. Individual clips and fasteners are available on pages 284-285.



- ACS030 64-66 ... Complete Set
- ACS031 67 Complete Set
- ACS032 68 Complete Set
- ACS033 69 Complete Set
- ACS03470-72 ... Complete Set

WHEEL CYLINDERS

Wheel cylinders are priced individually. Hardware is not included.



- WC07.....64-66.....Rear
- WC28.....64-67.....Left Front
- WC29.....64-67.....Right Front
- WC03..... 67Rear
- WC22.....68-69.....Left Rear
- WC23.....68-69.....Right Rear
- WC05.....68-72.....Left Front
- WC06.....68-72.....Right Front
- WC03.....70-72.....Rear

DRUM BRAKES

Brake drums are sold individually.



- BD1267-72.....Front Drum, Finned
- BD0167-75.....Rear Drum, Finned

E-BRAKE CABLES

Parking brake cable sets contain all the individual cables and hardware needed to restore the system. Front, rear, and intermediate cables are also sold individually while supplies last. Sold in O.E. mild steel and stainless steel. The complete cable kits and rear cables listed in this section are for rear drum vehicles. Call for options if you have rear disc.



ADD "S" TO PART NUMBER FOR STAINLESS STEEL

• Complete Cable Sets

RSBCA01.....64-67.....Excluding Turbo 400
 RSBCA02.....67.....Turbo 400
 RSBCA03.....68-72.....Excluding Turbo 400
 RSBCA04.....68-72.....Turbo 400
 RSBCA05T.....73-75.....Turbo 400
 RSBCA05N.....73-75.....Excluding Turbo 400
 RSBCA05L.....76-77.....All Cars
 RSBCA06.....78-88.....All Cars

• Intermediate Brake Cables

EBC8001.....64-67.....Cutlass, Excl. Turbo 400
 EBC8005.....64-67.....Cutlass, Turbo 400
 EBC8010.....68-72.....Cutlass, Turbo 400
 EBC8011.....68-72.....Cutlass, Excluding Turbo 400
 EBC8008.....73-75.....Cutlass, Turbo 400
 EBC8018.....76-77.....Cutlass, All Center

• Rear Brake Cables

EBC9001.....64-67.....Cutlass, Excl. Turbo 400
 EBC9026.....64-67.....Cutlass, Turbo 400
 EBC9007.....68-72.....Cutlass, All
 EBC9011.....73-75.....Cutlass, Turbo 400
 EBC9018.....76-77.....Cutlass, All
 EBC9030.....78-88.....Cutlass, Short
 EBC9031.....78-88.....Cutlass, Long

• E-Brake Hardware

EBH3001.....64-77.....Olive Green Center Pull
 EBH3002.....64-75.....Center To Rear Silver Connector
 RSCLP23.....64-88.....Parking Brake Clip - Black
 EBH2006.....64-67.....Front Hook
 EBH1001.....64-77.....Jam Nut
 EBH2007.....64-67.....Side Hook Excl. T-400
 EBH2002.....67.....Side Hook T-400
 EBH1003.....64-67.....Silver Washer Excl. T-400
 EBH1004.....64-67.....Self Tapper Excl. T-400
 EBH2005.....68-72.....Silver Rear Hook
 EBH2013.....68-72.....7-3/8" Hook T-400
 EBH2006.....68-75.....Front Hook Excl. T-400
 EBH2011.....73-77.....10-1/4 J Hook T-400
 EBH3004.....76-77.....Center to Rear Connector
 EBH2006.....76-77.....Front Hook
 EBH3002.....78-88.....Center to Rear Silver Connector
 EBH1005.....78-88.....5/16" Lock Nut
 EBH1006.....78-88.....5/16" x 3/4" Long Bolt
 EBH1007.....78-88.....Black Cable Clip

• Front Brake Cables

EBC7001.....64-67.....Cutlass, Excl. Turbo 400
 EBC7024.....64-67.....Cutlass, Turbo 400
 EBC7010.....68-72.....Cutlass, Turbo 400
 EBC7011.....68-72.....Cutlass, Excluding Turbo 400
 EBC7009.....73-75.....Cutlass, Turbo 400
 EBC7018.....76-77.....Cutlass, All
 EBC7028.....78-88.....Cutlass, All

SPINDLES

Our spindles are forged steel with precision CNC machining. Two hard to find caliper mounting bolts are included with each pair of spindles. 2" drop installations require caliper bracket and backing plate modifications. All listings are for disc brake systems. Call for drum brake applications.



DBSP01.....67-72.....Disc Brake Spindles with Large Bolts (pr)
 DBSP04.....67-72.....2" Drop Disc Brake Spindles with Bolts (pr)

BACKING PLATES

Often called dust shields, these plates provide some level of protection from road debris.



DBBP03.....67-68.....4 Piston Backing Plates (pr)
 DBBP01.....69-72.....Single Piston Backing Plates (pr)

CUTLASS - 442 CALIPERS, ROTORS & PADS

CALIPERS

New calipers are supplied loaded with pads*, banjo bolts and copper washers. No core charge applies. Mounting pins are provided when applicable. Black and Red powder coating options provide a smooth, finished look that is unaffected by leaking brake fluid. *Rebuild and new 4 piston calipers do not include pads or hardware. Core charges apply as noted.

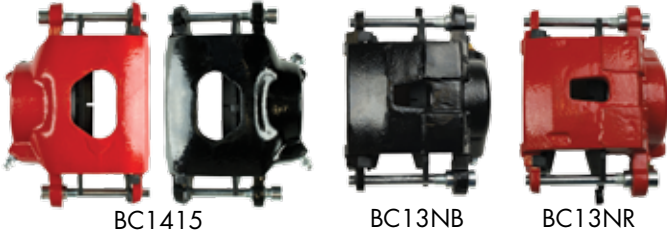

- BC1067-68..... 4 Piston, Left, with Exchange
- BC10C67-68..... Core Charge
- BC1167-68..... 4 Piston, Right, with Exchange
- BC11C67-68..... Core Charge
- CB6901 69 Caliper Bolts, Single Piston (ea.)
- BC14N.....69-72..... Left Front, New with pads
- BC15N.....69-72..... Right Front, New with pads
- BC141569-72..... Red, Black, or Powdercoat (pr)
- BC080973-77..... Red or Black Powdercoat (pr)
- BC12N.....78-88..... Left Front, New with Pads
- BC13N.....78-88..... Right Front, New with Pads
- BC121378-88..... Red or Black Powdercoat (pr)

ROTORS

Brake rotors are shipped with bearing races installed. A Drilled-Slotted-Zinc Plated option is available on select rotors.



- BR01C..... 67-68 Front Rotor, 4 Piston, 1 Pc Design
- BR69C..... 67-69 Front Rotor, 4 Piston, 2 Pc Design
- BR02C..... 69-72 Front Rotor, 1 Pc Design
- BR03C..... 73-77 Front Rotor
- Call Us! 78..... Front Rotor
- BR22C..... 79-81 Front Rotor
- Call Us! ... 82-88 Front Rotor, RWD

CALIPER BRACKETS

Yellow zinc plating provides corrosion protection on these reproduction brackets.

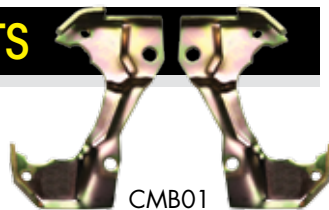

- CMB06 67-68 4 Piston Caliper Brackets (pr)
- CMB01 69-72 Single Piston Caliper Brackets (pr)

DISC BRAKE PADS

Brake pads are sold in sets of four. Our base line is a midgrade standard offering. Step up to the Silencer Professional line for less dust, quieter braking, and longer pad life.



SILENCER PROFESSIONAL

- DP01 67-68 4 Piston Caliper Pads (2 pr)
- DP02.... 69-77 Single Piston Caliper Pads (2 pr)
- DP23.... 78-88 Single Piston Caliper Pads (2 pr)
- DP23.... 64-88 Rear Pads (2 pr), with RSD Rear Disc

MINI KITS

Mini kits include a pair of spindles, caliper brackets, and backing plates. These kits are a great value to freshen up the front end on a restoration project, or to build out a drum to disc brake conversion.

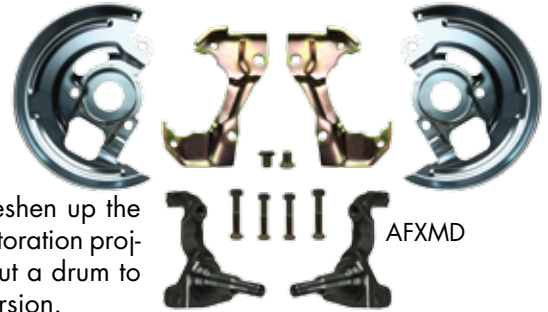

- AFXMD.....69-72..... Mini Conversion Kit, Includes: Spindles, Backing Plates, Caliper Brackets
- AFXMD4....69-72..... 2" Drop, Single Piston Calipers
- AFXMD367-68..... Standard Height, 4 Piston Piston Calipers

BRAKE SHOES

Shoes are sold in sets of four. Upgrade to the Silencer Precision series for quiet, low dust braking and longer shoe life.



- SILENCER PRECISION**
- Cost
- BS01 67-69 9" Drum Shoes, 2 pr
- BS245 64-72 9" Drum Shoes, 2 pr, Silencer Precision
- BS246.....70-71 Cutlass, Front Silencer Precision Shoes



CUTLASS - 442 BRAKE BOOSTER COMBOS

SLIMLINE BOOSTER MASTER COMBOS

J81315672

The slimline combos offer clean lines and plenty of power in a small package. The 8" dual is our favorite. Mounting brackets included.

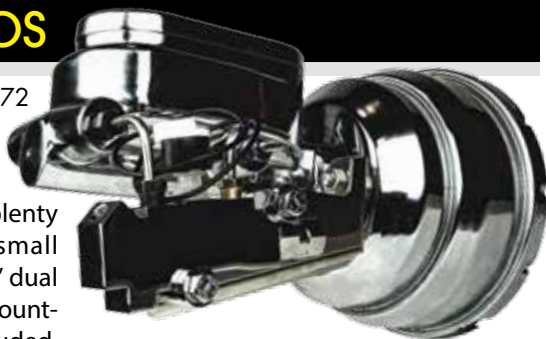

J81315672 TOP VIEW

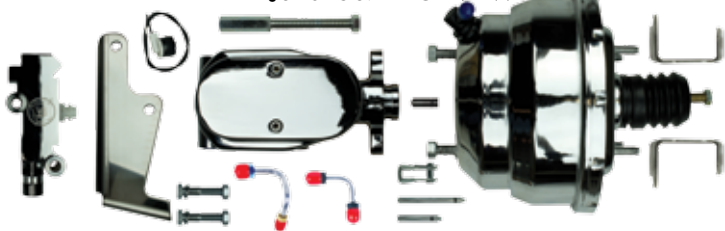

- G81310971 64-72 Gold 8" Dual, Disc/Drum
- J81315171 64-72 Chrome 8" Dual Disc/Drum
- G81310572 64-72 Gold 8" Dual, Disc/Disc
- J81315672 64-72 Chrome 8" Dual Disc/Disc
- G91020971 64-72 Gold 9" Single, Disc/Drum
- G91020572 64-72 Gold 9" Single, Disc/Disc

SLIMLINE BOOSTERS

Slimline boosters pack a lot of punch in a small, sleek package. Dual diaphragm versions provide 25% - 35% more assist than their single diaphragm equivalent. The 8" dual is our most popular for clearing big blocks while providing plenty of assist for two or four wheel disc brake systems. Mounting brackets included.



RPB7137



RPB7137C



RPB8131



RPB8131C

- RPB7137 64-72 7" Dual, Standard Gold
- RPB7137C 64-72 7" Dual, Chrome Plated
- RPB7137S 64-72 7" Dual, Polished Stainless
- RPB8131 64-72 8" Dual, Standard Gold
- RPB8131C 64-72 8" Dual, Chrome Plated
- RPB8131S 64-72 8" Dual, Polished Stainless
- RPB9102 64-72 9" Single, Standard Gold

DELCO BOOSTER MASTER COMBOS

Factory style for 67-72 GM. Can be tight on big block cars. Available with or without Delco stamping. Mounting brackets included. 11" is our most popular.



G91210971

G91210971 TOP VIEW



- G91210971 64-72 Gold 9" Single Disc/Drum
- J91215171 64-72 Chrome 9" Single, Disc/Drum
- G91210572 64-72 Gold 9" Single Disc/Disc
- J91215672 64-72 Chrome 9" single, Disc/Disc
- G10030971 67-72 Gold 11" Single Disc/Drum
- J10035171 67-72 Chrome 11" Single, Disc/Drum
- G10030572 67-72 Gold 11" Single Disc/Disc
- J10035672 67-72 Chrome 11" Single, Disc/Disc

DELCO BOOSTERS

Reproductions based on original factory units. GM licensed & feature a Delco Moraine stamping. This logo is available right side up and upside down. Unstamped boosters are of identical quality, but less expensive without the licensing fees. Includes mounting brackets.



RPB1001



RPB1003



RPB1003C

- RPB9121 64-72 9" Single Gold
- RPB9016 64-72 9" Standard Gold, with Delco Stamping
- RPB9121C 64-72 9" Single Chrome
- RPB1001 64-72 11" Single, Gold with Delco Stamp
- RPB1008 67-72 11" Single, Gold Upside Down Stamp
- RPB1003 67-72 11" Single Gold
- RPB1003C 67-72 11" Single Chrome

CUTLASS - 442 MASTER CYLINDERS & FUEL LINES

MASTER CYLINDERS

Master cylinders are completely new units with no core charge. A deep cylinder pocket with a removable plug provides compatibility with manual brakes as well as power-assisted applications.



- DBMC0567-69... Power Disc, 1" Bore, Deep Pocket
- DBMC08 64-66 ... Drum, Single Outlet, 1" Bore
- DBMC07 67-72 ... Drum, 1" Bore, ** Rebuilt
- DBMC09 67-70 ... Power Disc, 1-1/8" Bore, Deep
- DBMC11 67-68 ... Power Disc, with Bleeders, 1-1/8" Bore, Deep, Exact Repo for '69, Delco Licensed
- DBMC16 67-68 ... Power Disc, with Bleeders, 1-1/8" Bore, Deep, Same as DBMC11 without Casting Marks
- DBMC01 69-76 ... Power Disc, 1-1/8" Bore, Shallow
- DBMC09C.. 67-69 ... 1-1/8" Bore, Chrome
- DBMC05C.. 67-69 ... 1" Bore, 4 Wheel Disc, Chrome
- DBMC51C.. 67-69 ... 1-1/8" Bore, Slimline Flat Top, Chrome
- DBMC56C.. 67-69 ... 1" Bore, Slimline Flat Top, Chrome

VALVES & BLOCKS

We offer a full line of metering blocks, proportioning valves, distribution blocks and combination valves for factory drum and disc brake applications.

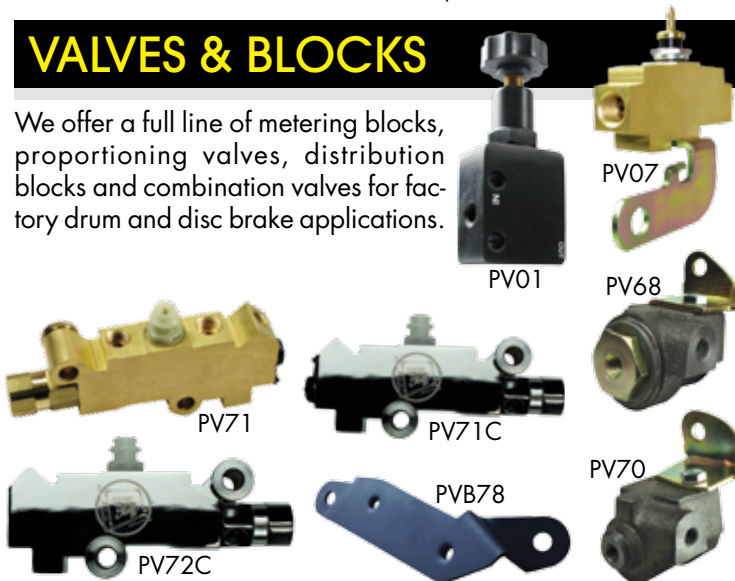

- PV01 Adjustable Valve
- PV6867-69..... Factory Hold-Off Valve with Bracket
- PV0667-69..... Distribution Block
- PV70 70 Hold-Off Valve with Bracket
- PV0770-72..... Distribution Block
- PV7171-77..... Disc/Drum Combination Valve, Brass
- PV71C.....71-77..... Disc/Drum Combination Valve, Chrome
- PV7271-77..... Disc/Disc Combination Valve, Brass
- PV72C.....71-77..... Disc/Disc Combination Valve, Chrome
- PVB7871-72..... Disc Brake Valve Bracket
- AMB7001..... Proportioning Valve

FUEL PUMP TO CARB LINES

Fuel pump to carburetor lines connect the fuel pump to the carburetor. Brass blocks and fittings are included as noted. These lines are intended to work only with factory pump, motor, intake and carburetor combinations.



ADD "S" TO PART NUMBER FOR STAINLESS STEEL

- APC5701 57 J2 Tri Carb
- APC6301 63 394, 4 BBL
- APC6502 65 442
- APC6602 ... 66-67 ... 8 Cylinder with 4 BBL
- APC6603 ... 66-67 ... 442, 389 Tri-Power
- APC6803 ... 68-69 ... 400, 4 BBL
- APC6801 ... 68-72 ... 8 Cylinder with 2 BBL
- APC68ED ... 68-72 ... 350, Edelbrock 4 BBL
- APC6930 69 Olds with 442 W-30/W-32 Ram Air
- APC7030 70 W-30 Only
- APC6802 ... 70-71 ... 8 Cylinder with 4 BBL
- APC7131 ... 71-72 ... W-31, 2-Pieces.
- APC7207 72 350, 4 BBL
- APC7204 ... 72-74 ... with 455
- FPC790379-81 ... with 403

MAIN FUEL LINES

Main lines carry fuel from the tank in the rear of the car to the fuel pump or rail in the front. They are available in 3/8" and 5/16" tubing based on factory specifications. Multiple piece sets are noted. Call for 1/2" lines.

ADD "S" TO PART NUMBER FOR STAINLESS STEEL

- AGL6101 . 61-62 ... 3/8" Main Line Hardtop
- AGL6201 . 62-63 ... 5/16" Hardtop
- AGL630163 Hardtop, Main
- AGL650165 3/8" Main, Vista Cruiser
- AGL650365 3/8" Main, 442, Convertible
- AGL650465 3/8" Main, 442, 400ci. Holiday Cpe
- AGL650565 3/8" Main Line Hardtop 442
- AGL660366 3/8" Convertible
- AGL660466 1/4" Convertible
- AGL6701 . 64-67 ... 3/8" Main Line Hardtop
- AGL6702 . 64-67 ... 3/8" Main Line Convertible
- AGL6801 . 68-69 ... 3/8" Main Line Hardtop
- AGL6803 . 68-69 ... 3/8" Main Line Convertible
- AGL7001 . 70-72 ... 3/8" Main Line Hardtop
- AGL7003 . 70-72 ... 3/8" Main Line Convertible
- AGL7501 . 73-77 ... 3/8" Main Line Hurst Olds
- AGL840184 3/8" Cutlass with 305 Main Line
- AGL8601 . 81-87 ... 3/8" Main Fuel Line, 3-Piece

RETURN FUEL LINES

Return lines carry excess fuel from fuel pump or fuel filter back to the tank. Not all vehicles were equipped with a return line. They are typically made of 1/4" diameter tubing.

ADD "S" TO PART NUMBER FOR STAINLESS STEEL

- AGL6102 ... 61-62 ... 1/4" Return
- AGL6302 63 1/4" Return, Hardtop
- AGL6710 67 1/4" Return Line Hardtop
- AGL6714 67 1/4" Return Line Convertible
- AGL6802 ... 68-69 ... 1/4" Return Line Hardtop
- AGL6804 ... 68-69 ... 1/4" Return Line Convertible
- AGL7002 ... 70-72 ... 1/4" Return Line Hardtop
- AGL7004 ... 70-72 ... 1/4" Return Line Convertible
- AGL7502 ... 73-77 ... 1/4" Return Line Hurst Olds, 2-Piece.
- AGL8603 ... 81-87 ... 1/4" Return Line

VAPOR RETURN LINES

Emission control systems use these 5/16" lines to handle fuel vapors. Some vehicles use a single front to rear line. Others utilize a charcoal canister and require 3 or 4 additional small lines.

ADD "S" TO PART NUMBER FOR STAINLESS STEEL

- AGL6103 61-62 ... 3/16" Vent
- AEM7004 70 Convertible
- AEM7103 ... 71-72 ... Hardtop
- AEM7104 ... 71-72 ... Convertible
- AGL7503 73-77 ... 5/16" Vapor Line, Hurst Olds
- AGL8602 81-87 ... 5/16" Vapor Line

FUEL HOSE KITS

These small rubber hoses and clips are used to connect fuel lines to the fuel pump and sending unit.



- FHK3800.....ALL..... 3/8" x 6", 3/8" x 13", + 4 Green Clamps
- FHK1438.....ALL..... 3/8" x 6", 3/8" x 13", 1/4" x 18"
with 4 Green Clamps and 4 Red Clamps

FUEL LINE CLIPS

Fuel line clips hold tubing to the frame or body of the car. Fasteners are included as noted. See pages 284-285 for individual clips.

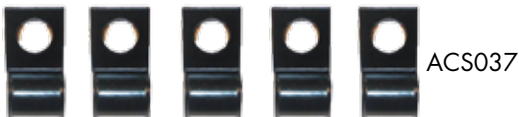

- ACS035 ... 64-67 ... with 5/16" Fuel Line Only 5 Pcs.
- ACS036 ... 64-67 ... with 5/16" Fuel Line & 1/4" Return 10 Pcs.
- ACS037 ... 64-67 ... with 3/8" Fuel Line Only 5 Pcs.
- ACS038 ... 64-67 ... with 3/8" Fuel Line & 1/4" Return 10 Pcs.
- ACS039 ... 68-69 ... with 3/8" Fuel Line Only 5 Pcs.
- ACS040 ... 68-69 ... with 3/8" Fuel Line & 1/4" Return 5 Pcs.
- ACS041 70 with 3/8" Fuel Line Only 5 Pcs.
- ACS042 70 with 3/8" Fuel Line & 1/4" Return 5 Pcs.
- ACS043 ... 71-72 ... with 3/8" Fuel & 5/16" Vapor 6 Pcs.

SUSPENSION PARTS

UPPER & LOWER BALL JOINTS

XK5103  XK5108 

- XK5103 64-72 Lower
- XK5108 64-72 Upper
- XK6145 73-87 Lower
- XK5208 73-87 Upper

INNER & OUTER TIE RODS & SLEEVES

XES681N 

- XES681N 64-70 Inner
- XES333RL 64-70 Outer
- XES2032S ... 64-70 Adjusting Sleeve
- XES2004S ... 71-77 Adjusting Sleeve
- XES427R 73-77 Outer

STEERING ARMS

DBSA01 64-72 Steering Arm, 1/2" Bolt Holes (pr)

UPPER & LOWER CONTROL ARM BUSHING KITS



- XK5144 64-66 Lower
- XK5196 64-72 Upper
- XK6076 66-72 Lower, Circular holes
- XK5149 66-72 Lower, Oval holes
- XK6108 73 Upper
- XK6109 73-77 Lower
- XK6144 74-77 Upper

SWAY BAR BUSHINGS



- XK5241 64-77 15/16" or Smaller
- XK5241 76-80 15/16" with Tabs on Mounting Clamp
- XK5253 64-75 1" or Larger Bar
- XK6161 76-80 1" to 1-1/8" Bar with Tabs on Clamp

IDLER ARMS



- CIA6401 64-67 Idler Arm with 7/8" Center Link
- CIA6801 64 Idler Arm with 3/16" Center Link
- CIA6801 68-72 Idler Arm with 3/16" Center Link

FUEL TANK VENT LINES

Fuel tank vent lines allow the air inside the fuel tank to escape as it is filled with fuel. They also prevent pressure from building up due to temperature changes.

- AFV6505 1965 ... 5/16" Fuel Vent Line - OE Steel
- AFV6505S ... 1965 ... 5/16" Fuel Vent Line - Stainless

CUTLASS - 442 FRONT BRAKE CONVERSIONS

**STREET
SERIES**

FRONT DISC BRAKE CONVERSION KITS

U.S.A. Made
TIMKEN Bearings

FRONT CONVERSIONS INCLUDE:

- 11" Rotors
- Forged Spindles
- Timken Bearings
- New Calipers
- Caliper Brackets
- Organic Pads
- Backing Plates
- Flex Hoses & Clips
- Valve Bracket & Hardware
- Banjo Bolts & Copper Washers
- Dust Caps
- Castle Nuts & Pins
- Washers
- Grease Seals
- Spindle Gaskets
- Steering Arm Bolts
- Master Cylinder
- Combination Valve
- Pedal Rod Extension
- Brake Switch Pigtail

WORKS WITH FACTORY 14" & LARGER DISC BRAKE WHEELS

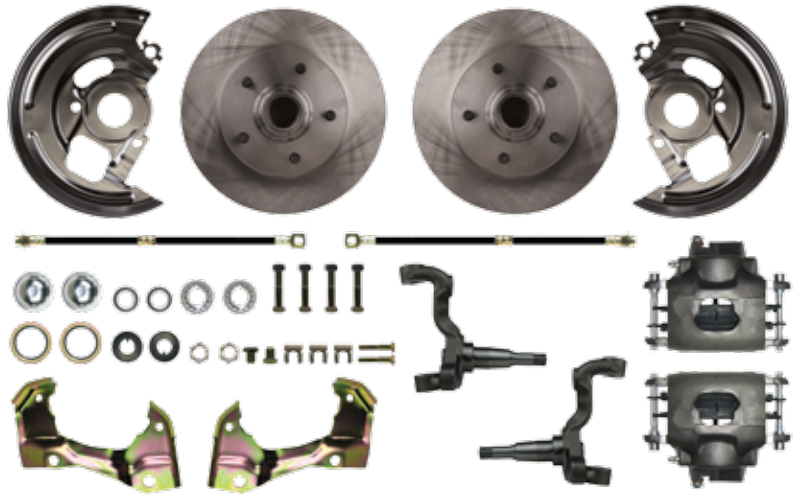

Packages include At-the-Wheel Disc Conversion Kit & Master Cylinder with Valve (Manual) or Master Cylinder with Booster and Valve (Power).

POWER PACKAGE

MANUAL PACKAGE

AT-THE-WHEEL FRONT KITS From

Disc conversions are the most complete kits in the industry at the right price. High quality components, professional packaging, and after-sale support by "hands-on" technicians. Consider one of our complete brake line packages for a care-free installation.

EARLY 4 LUG NOVAS WILL NEED PART DBSA02 STEERING ARMS (SEE PAGE 205) TO COMPLETE INSTALL

STOCK HEIGHT FRONT KITS

- AFXWK01C64-72..... At-the-Wheel Disc Conversion Kit
- AFXSD01C.....64-72..... Manual Disc Conversion Package
- AFXDC01C64-72..... 9" Power Disc Conversion Package
- AFXDC06C67-72..... 11" Power Disc Conversion Package

2" DROP FRONT KITS

- AFXWK01D64-72..... At-the-Wheel Disc Conversion Kit
- AFXSD01D.....64-72..... Manual Disc Conversion Package
- AFXDC01D64-72..... 9" Power Disc Conversion Package
- AFXDC06D67-72..... 11" Power Disc Conversion Package

SUSPENSION KITS

Standard rubber kits meet O.E. specifications. Polyurethane kits provide better handling and a firmer ride. Poly kits include upgraded control arm bushings, sway bar bushings, and sway bar links. Pre-packaged kits offer huge savings over individual suspension parts. Most kits include the following:

- Lower Ball Joints (2)
- Upper Ball Joints (2)
- Lower Ctrl. Arm Bushings (4)
- Upper Ctrl. Arm Bushings (4)
- Inner Tie Rods (2)
- Sway Bar Link Kits (2)
- Tie Rod Adj. Sleeves (2)
- Sway Bar Bushings (2)
- Outer Tie Rods (2)

**COMING
IN 2017**

CSK7301



- CSK6401 ... 66-70 ... Front Rebuild Kit, Circular Hole in Control Arm, 22-Piece
- CSK6401U . 66-70 ... Front Rebuild Kit, Circular Hole in Control Arm, 22-Piece (Poly)
- CSK6501 ... 64-65 ... Complete Kit, Circular Hole in Control Arm, 22-Piece, Uses 1.9" Bushing
- CSK6501 ... 64-65 ... Complete Kit, Circular Hole in Control Arm, 22-Piece (Poly), Uses 1.9" Bushing
- CSK7001 ... 66-72 ... Complete Kit, Oval Hole in Control Arm, 22-Pc
- CSK7001U . 66-72 ... Complete Kit, Oval Hole in Control Arm, 22-Piece (Poly)
- CSK7301 73 Front Rebuild Kit, 22-Piece
- CSK7401 ... 74-75 ... Front Rebuild Kit, 22-Piece
- CSK7601 ... 76-77 ... Front Rebuild Kit, 24-Piece with 1-1/8" & 1-3/16" Sway Bar with Tabs on Mounting Clamps
- CSK7801 ... 78-87 ... Front Rebuild Kit, 24-Piece with 1" & 1-1/16" Sway Bar without Tabs on Mounting Clamps
- CSK7802 ... 78-87 ... Front Rebuild Kit, 24-Piece with 1-1/8" & 1-1/4" Sway Bar without Tabs on Mounting Clamps
- CSK7803 ... 78-87 ... Front Rebuild Kit, 24 Ps. with 1-5/16" & 1-7/16" Sway Bar without Tabs on Mounting Clamps

FRONT DISC BRAKE CONVERSION UPGRADES

STREET SERIES

SHOW'N GO UPGRADE TRIM KITS

These At-the-Wheel Disc Conversion Kits (stock height or 2" drop) include upgraded drilled slotted rotors with zinc plating, powder coated calipers in red or black, and braided stainless hoses.



STOCK HEIGHT SHOW'N GO

AFXWK01CS 64-72 ... At-the-Wheel Disc Conversion Kit - Black
 AFXWK01CZ 64-72 ... At-the-Wheel Disc Conversion Kit - Red
 AFXSD01CS 64-72 ... Manual Disc Conversion Package - Black
 AFXSD01CZ 64-72 ... Manual Disc Conversion Package - Red
 AFXDC01CS 64-72 ... Power Disc Conversion Package - Black
 AFXDC01CZ 64-72 ... Power Disc Conversion Package - Red

2" DROP SHOW'N GO

AFXWK01DS 64-72 ... At-the-Wheel Disc Conversion Kit - Black
 AFXWK01DZ 64-72 ... At-the-Wheel Disc Conversion Kit - Red
 AFXSD01DS 64-72 ... 2" Drop Manual Disc Conv Pkg - Black
 AFXSD01DZ 64-72 ... 2" Drop Manual Disc Conv Pkg - Red
 AFXDC01DS 64-72 ... 2" Drop Power Disc Conv Pkg - Black
 AFXDC01DZ 64-72 ... 2" Drop Power Disc Conv Pkg - Red

SHOW STOPPER TRIM PACKAGES

Includes At-the-Wheel Front Disc Conversion Kit (stock height or 2" drop) with natural finish calipers. The Manual Packages get an upgraded chrome plated master cylinder and combination valve with bracket. Power Packages include an upgraded 8" dual chrome booster.



STOCK HEIGHT SHOW STOPPER

AFXSD01CX 64-72 ... Manual Disc Conversion Package
 AFXDC01CX 64-72 ... 8" Power Disc Conversion Package

2" DROP SHOW STOPPER

AFXSD01DX 64-72 ... Manual Disc Conversion Package
 AFXDC01DX 64-72 ... 8" Power Disc Conversion Package

BEST OF SHOW TRIM PACKAGES

Includes At-the-Wheel Front Disc Conversion Kit (stock height or 2" drop) with black or red calipers. The Manual Packages get an upgraded chrome plated master cylinder and combination valve with bracket. Power Packages include an upgraded 8" dual chrome booster.



STOCK HEIGHT BEST OF SHOW

AFXSD01CSX 64-72 ... Manual Disc Conversion Package - Blk
 AFXSD01CZX 64-72 ... Manual Disc Conversion Package - Red
 AFXDC01CSX 64-72 ... 8" Power Disc Conversion Package - Blk
 AFXDC01CZX 64-72 ... 8" Power Disc Conversion Package - Red

2" DROP BEST OF SHOW

AFXSD01DSX 64-72 ... Manual Disc Conversion Package - Blk
 AFXSD01DZX 64-72 ... Manual Disc Conversion Package - Red
 AFXDC01DSX 64-72 ... 8" Power Disc Conversion Package - Blk
 AFXDC01DZX 64-72 ... 8" Power Disc Conversion Package - Red



Disc Brake Conversions require special brake lines that fit your new disc conversion setup. Right Stuff offers "No Brainer" Brake Line Kits that include all components needed from your master cylinder back to your rear wheel cylinder or calipers. They include front brake line kit, front to rear line, rear axle lines & flex hose, & clip set.

See page 218 for your application

CUTLASS - 442 4-WHEEL BRAKE CONVERSIONS

**STREET
SERIES**

FOUR WHEEL DISC BRAKE CONVERSION KITS



FOUR WHEEL CONVERSIONS INCLUDE:

- 11" Rotors
- Forged Spindles
- Timken Bearings
- New Calipers
- Caliper Brackets
- Organic Pads
- Backing Plates
- Flex Hoses & Clips
- Valve Bracket & Hardware
- Banjo Bolts & Copper Washers
- Rear Bracket Spacers
- Weld-On Hose Brackets
- Dust Caps
- Castle Nuts & Pins
- Washers
- Grease Seals
- Spindle Gaskets
- Steering Arm Bolts
- Master Cylinder
- Combination Valve
- Pedal Rod Extension
- Brake Switch Pigtail
- E-Brake Cables

Right Stuff disc conversions are the most complete kits in the industry at the right price. High quality components, professional packaging, and after-sale support by "hands-on" technicians create an unbeatable value. Consider one of our complete brake line packages for a care-free installation. See page 211 to verify axle flange measurements for these kits.

WORKS WITH 15" AND LARGER WHEELS

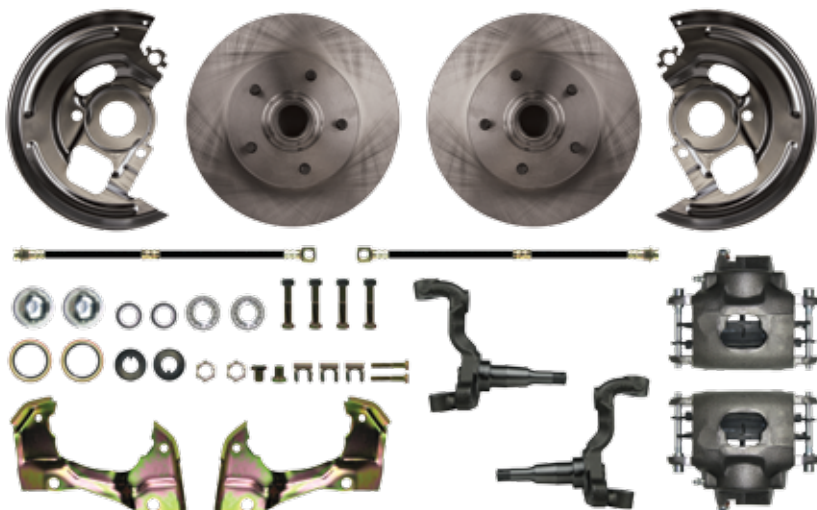

AT-THE-WHEEL FRONT KIT

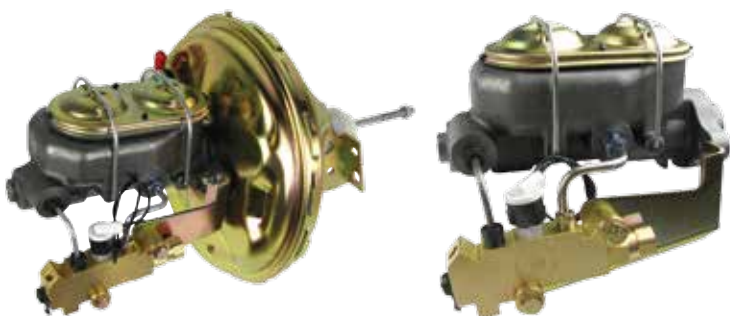

Packages include At-the-Wheel Disc Conversion Kits & Master Cylinder with Valve (Manual) or Master Cylinder with Booster and Valve (Power).

POWER PACKAGE

MANUAL PACKAGE

9" or 11" booster Call for other diameters

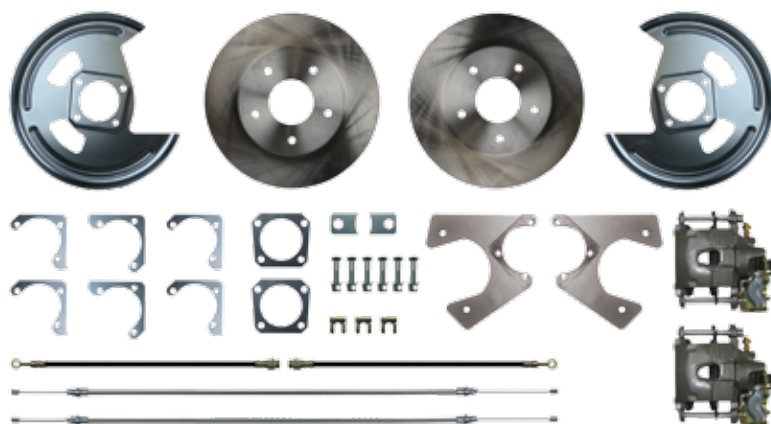

AT-THE-WHEEL REAR KIT

6-3/16" INSIDE ROTOR DIAMETER - 2.78" CENTER HOLE

STOCK HEIGHT 4-WHEEL KITS

- AFXSD41C... 64-72 ... Manual Disc Brake Conversion Package
- AFXDC41C... 64-72 ... 9" Power Disc Brake Conversion Package
- AFXDC46C... 67-72 ... 11" Power Disc Brake Conversion Package

2" DROP 4-WHEEL KITS

- AFXSD41D... 64-72 ... Manual Disc Brake Conversion Package
- AFXDC41D... 64-72 ... 9" Power Disc Brake Conversion Package
- AFXDC46D... 67-72 ... 11" Power Disc Brake Conversion Package

UPGRADES The next page offers upgrades to fully customize your conversion kit.



Disc Brake Conversions require special brake lines that fit your new disc conversion setup. Right Stuff offers "No Brainer" Brake Line Kits that include all components needed from your master cylinder back to your rear wheel cylinder or calipers. They include front brake line kit, front to rear line, rear axle lines & flex hose, & clip set.

See page 218 for your application

CUTLASS - 442 4-WHEEL BRAKE UPGRADES

4-WHEEL DISC BRAKE CONVERSION UPGRADES

STREET SERIES

SHOW'N GO UPGRADE TRIM KITS

These At-the-Wheel Disc Conversion Kits (stock height or 2" drop) include upgraded drilled slotted rotors with zinc plating, powder coated calipers in red or black, and braided stainless hoses.



STOCK HEIGHT SHOW'N GO

AFXSD41CS...64-72... Manual Disc Brake Conv Package - Black
AFXSD41CZ...64-72... Manual Disc Brake Conv Package - Red
AFXDC41CS...64-72... Power Disc Brake Conv Package - Black
AFXDC41CZ...64-72... Power Disc Brake Conv Package - Red

2" DROP SHOW'N GO

AFXSD41DS...64-72... 2" Drop Manual Disc Brake Conv Pkg - Black
AFXSD41DZ...64-72... 2" Drop Manual Disc Brake Conv Pkg - Red
AFXDC41DS...64-72... 2" Drop Power Disc Brake Conv Pkg - Black
AFXDC41DZ...64-72... 2" Drop Power Disc Brake Conv Pkg - Red

SHOW STOPPER TRIM PACKAGES

Includes At-the-Wheel Front Disc Conversion Kit (stock height or 2" drop) with natural finish calipers. The Manual Packages get an upgraded chrome plated master cylinder and combination valve with bracket. Power Packages include an upgraded 8" dual chrome booster.

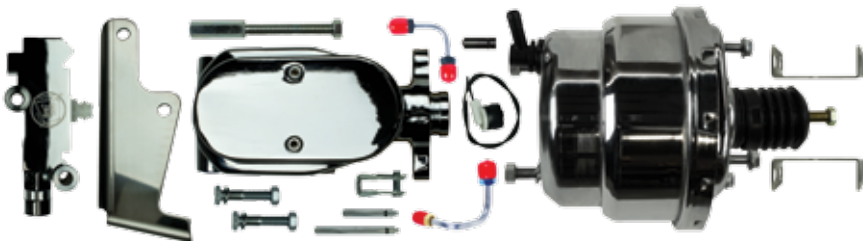

STOCK HEIGHT SHOW STOPPER

AFXSD41CX...64-72... Manual Disc Brake Conversion Package
AFXDC41CX...64-72... 8" Power Disc Brake Conversion Package

2" DROP SHOW STOPPER

AFXSD41DX...64-72... Manual Disc Brake Conversion Package
AFXDC41DX...64-72... 8" Power Disc Brake Conversion Package

BEST OF SHOW TRIM PACKAGES

Includes At-the-Wheel Front Disc Conversion Kit (stock height or 2" drop) with black or red calipers. The Manual Packages get an upgraded chrome plated master cylinder and combination valve with bracket. Power Packages include an upgraded 8" dual chrome booster.



STOCK HEIGHT BEST OF SHOW

AFXSD41CSX...64-72... Manual Disc Brake Conversion Pkg - Black
AFXSD41CZX...64-72... Manual Disc Brake Conversion Pkg - Red
AFXDC41CSX...64-72... 8" Power Disc Brake Conversion Pkg - Blk
AFXDC41CZX...64-72... 8" Power Disc Brake Conversion Pkg - Red

2" DROP BEST OF SHOW

AFXSD41DSX...64-72... Manual Disc Brake Conversion Pkg - Black
AFXSD41DZX...64-72... Manual Disc Brake Conversion Pkg - Red
AFXDC41DSX...64-72... 8" Power Disc Brake Conversion Pkg - Blk
AFXDC41DZX...64-72... 8" Power Disc Brake Conversion Pkg - Red



CUTLASS - 442 REAR BRAKE CONVERSIONS

**STREET
SERIES**

REAR DISC BRAKE CONVERSION KITS

REAR CONVERSIONS INCLUDE:

- 11" Rotors
- Caliper Brackets & Spacers
- Weld-On Hose Brackets
- Flex Hoses
- Backing Plates (Exclusive), not for AFXRD78 or AFXRDM78
- New Loaded Caliper
- E-Brake Cables
- Hardware

Right Stuff disc conversions are the most complete kits in the industry at the right price. High quality components, professional packaging, and after-sale support by "hands-on" technicians create an unbeatable value. Consider one of our complete brake line packages for a carefree installation. See the next page to verify axle flange measurements for these kits.

NOTE:

FITS FACTORY
REAR ENDS
CALL FOR CUSTOM
APPLICATIONS

WORKS WITH 15" AND LARGER WHEELS

6-3/16" INSIDE ROTOR DIAMETER - 2.78" CENTER HOLE

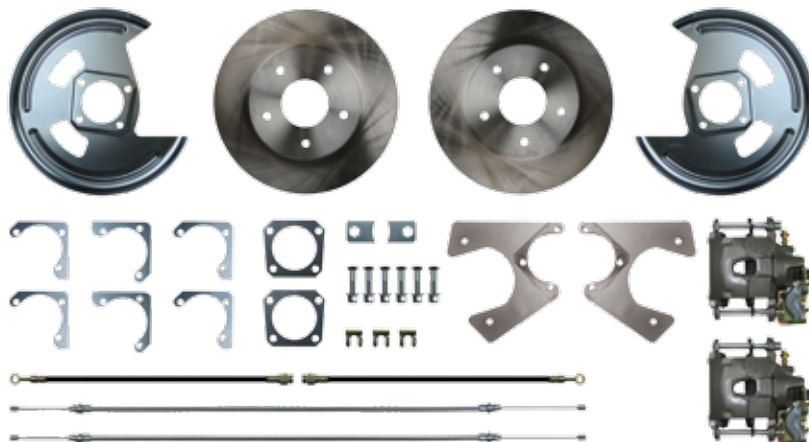

WANT MATCHING FRONT UPGRADES? SEE THE NEXT PAGE FOR OUR REAR+2 CONVERSIONS

ATTENTION Before you order, be sure to measure the axle flange on your vehicle.

REAR KITS WITH E-BRAKE

AFXRD01 64-77 10 & 12 Bolt
AFXRD78 78-88 10 Bolt

REAR KITS WITHOUT E-BRAKE

AFXRDM1 64-77 10 & 12 Bolt
AFXRDM78 78-88 10 Bolt

REAR DISC BRAKE CONVERSION UPGRADES

**STREET
SERIES**

SHOW'N GO UPGRADE TRIM PACKAGES

These Rear Disc Conversion Kits include upgraded drilled slotted rotors with zinc plating, powder coated calipers in red or black, and braided stainless hoses.



REAR UPGRADE WITH E-BRAKE

AFXRD01S 64-77 10 & 12 Bolt - Black
AFXRD01Z 64-77 10 & 12 Bolt - Red
AFXRD78S 78-88 10 Bolt - Black
AFXRD78Z 78-88 10 Bolt - Red

REAR UPGRADE W/O E-BRAKE

AFXRDM1S 64-77 ... 10 & 12 Bolt - Black
AFXRDM1Z 64-77 ... 10 & 12 Bolt - Red
AFXRDM78S ... 78-88 ... 10 Bolt - Black
AFXRDM78Z ... 78-88 ... 10 Bolt - Red

 **No Brainer
BRAKE LINE KITS**
DESIGNED FOR DISC CONVERSIONS

Disc Brake Conversions require special brake lines that fit your new disc conversion setup. Right Stuff offers "No Brainer" Brake Line Kits that include all components needed from your master cylinder back to your rear wheel cylinder or calipers. They include front brake line kit, front to rear line, rear axle lines & flex hose, & clip set.

See page 218 for your application

CUTLASS - 442 +2 BRAKE CONVERSIONS

STREET SERIES

REAR +2 DISC BRAKE CONVERSION KITS

REAR +2 CONVERSIONS INCLUDE:

- 11" Drilled-Slotted-Zinc Rear Rotors
- Black or Red Rear Powder Coated Calipers
- Braided Stainless Rear Hoses
- Brackets, Spacers, Hardware
- Weld-On Hose Brackets
- Backing Plates *TRSD Exclusive
- E-Brake Cables

Right Stuff disc conversions are the most complete kits in the industry at the right price. High quality components, professional packaging, and after-sale support by "hands-on" technicians create an unbeatable value. Get a rear conversion and matching front upgrades with a single part number.

NOTE:

FITS FACTORY REAR ENDS
CALL FOR CUSTOM APPLICATIONS

+2 KITS ALSO INCLUDE

- Drilled-Slotted-Zinc Front Rotors
- Black or Red Powder Coated Front Calipers
- Braided Stainless Front Hoses

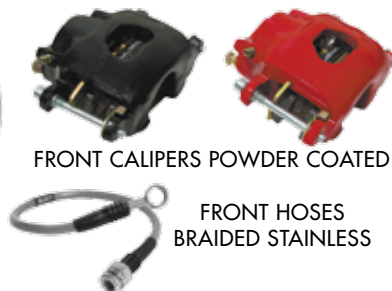

WORKS WITH 15" AND LARGER WHEELS
REAR DISC BRAKES + MATCHING FRONT UPGRADES
6-3/16" INSIDE ROTOR DIAMETER - 2.78" CENTER HOLE

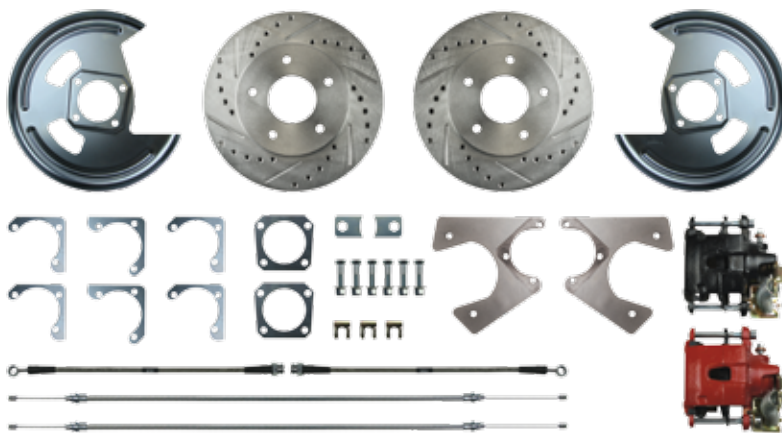

REAR +2 KITS WITH E-BRAKE

- A69RD01S 69-72 Black Calipers, Drilled/Slotted
- A69RD01Z 69-72 Red Calipers, Drilled/Slotted
- A73RD01S 73-77 Black Calipers, Drilled/Slotted
- A73RD01Z 73-77 Red Calipers, Drilled/Slotted
- A78RD78S 78 Black Calipers, Drilled/Slotted
- A78RD78Z 78 Red Calipers, Drilled/Slotted
- A79RD78S 79-81 Black Calipers, Drilled/Slotted
- A79RD78Z 79-81 Red Calipers, Drilled/Slotted
- A82RD78S 82-88 Black Calipers, Drilled/Slotted
- A82RD78Z 82-88 Red Calipers, Drilled/Slotted

REAR +2 KITS WITHOUT E-BRAKE

- A69RDM1S..... 69-72 Black Calipers, Drilled/Slotted
- A69RDM1Z 69-72 Red Calipers, Drilled/Slotted
- A73RDM1S..... 73-77 Black Calipers, Drilled/Slotted
- A73RDM1Z 73-77 Red Calipers, Drilled/Slotted
- A78RDM78S.....78 Black Calipers, Drilled/Slotted
- A78RDM78Z78 Red Calipers, Drilled/Slotted
- A79RDM78S... 79-81 Black Calipers, Drilled/Slotted
- A79RDM78Z .. 79-81 Red Calipers, Drilled/Slotted
- A82RDM78S... 82-88 Black Calipers, Drilled/Slotted
- A82RDM78Z .. 82-88 Red Calipers, Drilled/Slotted

AXLE FLANGE DIAGRAMS

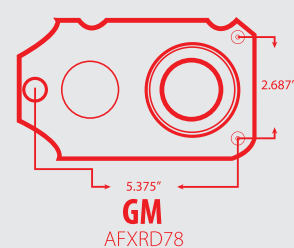
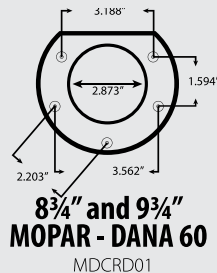
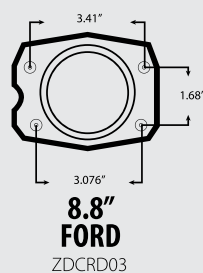
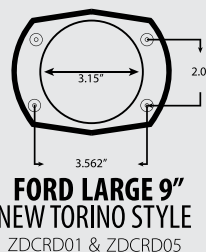
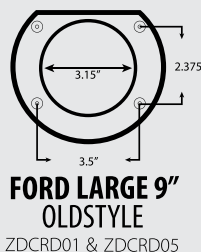
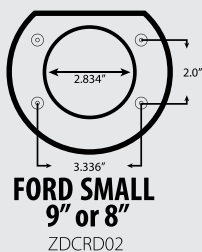
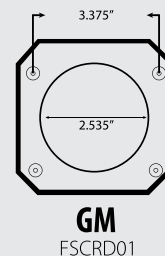
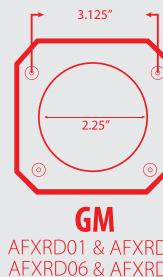
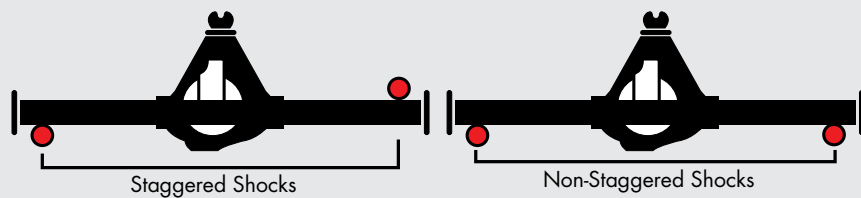

CUTLASS - 442 EZ FIT FRONT BRAKE CONVERSIONS



BRAKE•KITS

Fits stock 14" wheel. Bolts to stock drum or disc brake spindles. Minimal offset for better fenderwell clearance. Proprietary rotor.

EZ FIT BRAKE CONVERSION KITS

HALF THE INSTALL TIME
KEEP YOUR FACTORY
14" WHEELS

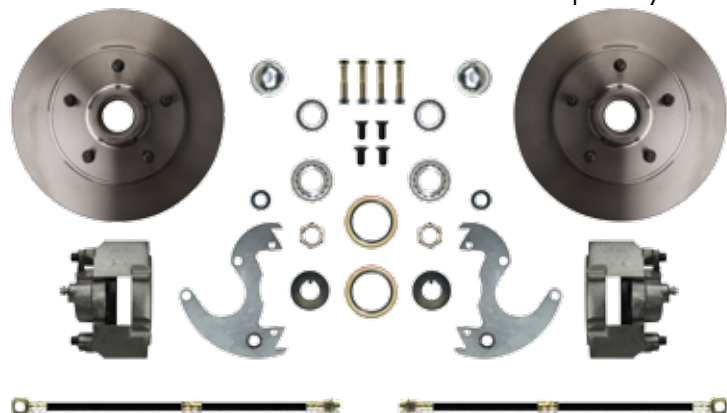

FRONT AT-THE WHEEL KITS

64-67 NOVA KITS COME WITH CORRECT 9 INCH 3 STUD BOOSTER

Available with standard stock-style rotors or upgraded drilled, slotted & zinc rotors.

FRONT 14" - STANDARD ROTORS

AFXWK14 ...64-72.....Front At-the-Wheel Disc Conversion Kit
 AFXSD14.....64-72.....Front Manual Disc Conversion Package
 AFXDC1464-72.....Front Power Disc Conversion Package

REAR 14" - STANDARD ROTORS

AFXRD14 64-77.... Rear Kit, Non-Staggered



LOOKING FOR A DIFFERENT BOOSTER + MASTER CYLINDER IN YOUR KIT?

Simply purchase an At-The-Wheel Kit above along with any Booster + Master combo on page 180.



EZ FIT FRONT CONVERSIONS INCLUDE:

- 10" Rotors with Organic Pads
- New Calipers & Brackets
- Banjo Bolts & Copper Washers
- Dust Caps, Castle Nuts & Pins
- Brake Switch Pigtail
- Master Cylinder (Power/Manual Kits)
- Timken Bearings
- Flex Hoses & Kit
- Grease Seals
- Steering Arm Bolts
- Combination Valve
- 9" Booster (Power)

EZ FIT REAR CONVERSIONS INCLUDE:

- Fits 14" wheels
- Uses proprietary rotor
- Built in e-brake (No cables included)



POWER PACKAGE



MANUAL PACKAGE

Packages include At-the-Wheel Disc Conversion Kits & Master Cylinder with Valve (Manual) or Master Cylinder with Booster and Valve (Power).

FRONT 14" - UPGRADE ROTORS

AFXWK14A ...64-72.... Front At-the-Wheel Disc Conversion Kit
 AFXSD14A.....64-72..... Front Manual Disc Conversion Package
 AFXDC14A64-72..... Front Power Disc Conversion Package

REAR 14" - UPGRADE ROTORS

AFXRD14A.....64-77.... Rear Kit, Non-Staggered



CUTLASS - 442 PERFORMANCE SERIES CONVERSIONS

Performance
SERIES

COMPLETE DISC BRAKE CONVERSION KITS

NEW

U.S.A. Made
TIMKEN Bearings

Right Stuff Performance Series disc conversions are the most complete kits in the industry at the right price. Designed for the performance street machine with high quality components, professional packaging, and after-sale support by "hands-on" technicians and many DIY videos at rightstuff create an unbeatable value.

Kits are available as a **Disc Brake Upgrade** that bolts to stock front disc brake spindles, or as an **At-The-Wheel Kit** that includes everything for a front disc brake conversion, and as a **Complete Conversion Kit** which includes everything in the At-The-Wheel Kit with the addition of the master cylinder, booster & prop valve (Power or Manual).

AT-THE-WHEEL CONVERSION KITS INCLUDE:

- 11" Drilled & Slotted Rotors
- Wilwood Dual Piston Calipers
- Caliper Brackets
- Backing Plates
- Timken Bearings
- Castle Nuts & Pins
- Dust Caps
- Forged Spindles
- Organic Pads
- Washers
- Grease Seals
- Spindle Gaskets
- Steering Arm Bolts
- Hardware

COMPLETE CONVERSION KITS ALSO INCLUDE

- Master Cylinder - Chrome or Standard Finish
- Flex Hoses & Clips
- Valve Bracket & Hardware
- Banjo Bolts & Copper Washers
- Combination Valve
- Brake Switch Pigtail
- Pedal Rod Extension

WORKS WITH 15" AND LARGER WHEELS

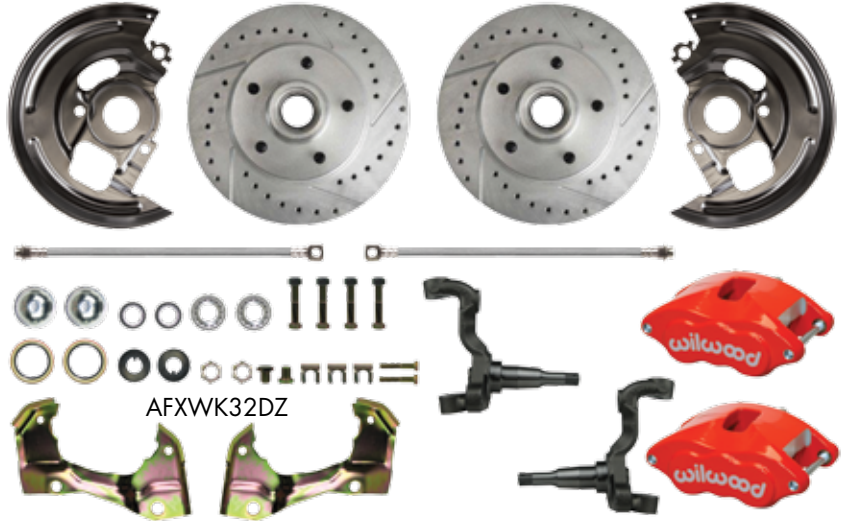

FRONT AT-THE-WHEEL KITS

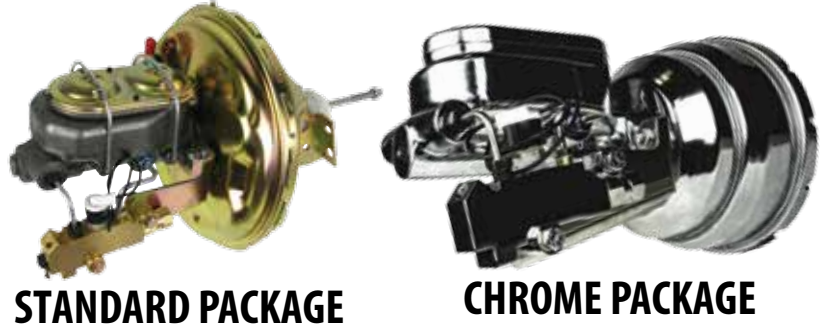

STANDARD PACKAGE

CHROME PACKAGE

Packages include At-the-Wheel Disc Conversion Kits and Chrome or Standard Finish Master Cylinder with Booster and Valve (Power).

AT-THE-WHEEL FRONT DISC KITS

AFXWK32S.....64-72... At-the-Wheel Stock Height - Black Wilwood
 AFXWK32Z64-72... At-the-Wheel Stock Height - Red Wilwood
 AFXWK32DS ...64-72... At-the-Wheel 2" Drop - Black Wilwood
 AFXWK32DZ ...64-72... At-the-Wheel 2" Drop - Red Wilwood

STOCK HEIGHT FRONT KITS

AFXDC32S.....64-72... Standard Booster/Master - Black Wilwood
 AFXDC32Z64-72... Standard Booster/Master - Red Wilwood
 AFXDC32SX.....64-72... Chrome Booster/Master - Black Wilwood
 AFXDC32ZX.....64-72... Chrome Booster/Master - Red Wilwood

2" DROP FRONT KITS

AFXDC32DS64-72... Standard Booster/Master - Black Wilwood
 AFXDC32DZ64-72... Standard Booster/Master - Red Wilwood
 AFXDC32DSX...64-72... Chrome Booster/Master - Black Wilwood
 AFXDC32DZX ..64-72... Chrome Booster/Master - Red Wilwood



DISC BRAKE UPGRADE KITS INCLUDE (Kit is Designed to Bolt to Stock Disc Brake Spindles)

- Wilwood 2-Piston Aluminum Calipers
- Cross-Drilled & Slotted Zinc Plated Rotors
- Braided Stainless Hoses
- Organic Brake Pads

DISC BRAKE UPGRADE KITS

RCP69S 69-72 Black 2-Piston Wilwood Calipers
 RCP69Z 69-72 Red 2-Piston Wilwood Calipers

CUTLASS - 442 SIGNATURE SERIES CONVERSION KITS



DISC BRAKE CONVERSION KITS

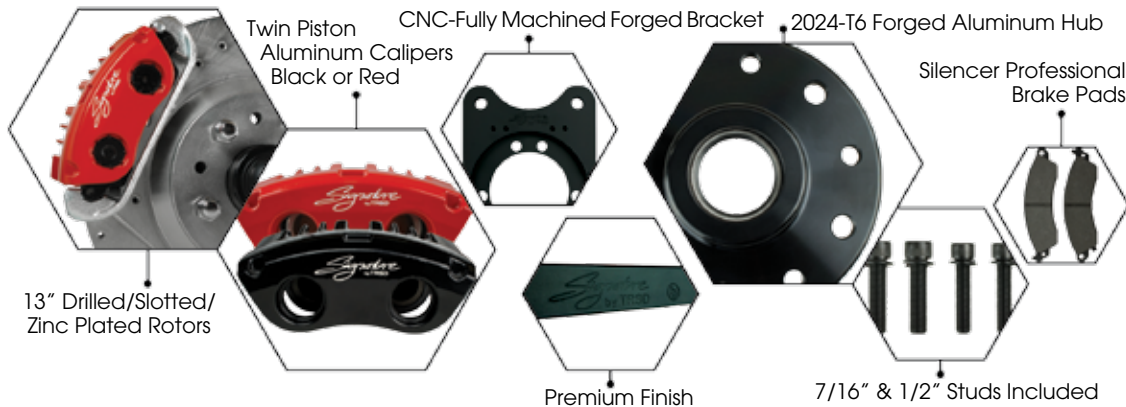

DESIGNED FOR 17\"/>

Bold looks define the Signature Series line of brake kits. Large diameter zinc plated rotors, powder coated calipers, fully machined caliper brackets, & braided stainless brake hoses. Only premium quality components make the grade. We back every kit with industry leading technical support. Signature Series kits are amazing brakes at a great price. Add a No Brainer Brake Line Kit for a true bolt-on install.

SIGNATURE SERIES FRONT KIT

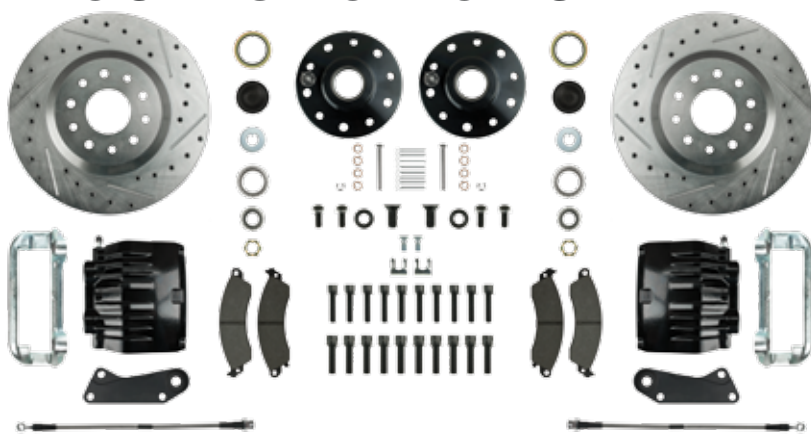

U.S.A. Made **TIMKEN** Bearings



STOCK HEIGHT FRONT KITS

Uses existing drum or disc brake spindles

- AFXWK31CS 64-72.....At-the-Wheel Kit - Black Calipers
- AFXWK31CZ 64-72.....At-the-Wheel Kit - Red Calipers
- AFXSD31CS 64-72.....Manual Kit - Black Calipers
- AFXSD31CZ 64-72.....Manual Kit - Red Calipers
- AFXDC31CS 64-72.....Power Kit - Black Calipers
- AFXDC31CZ 64-72.....Power Kit - Red Calipers

2" DROP FRONT KITS

Includes new 2" drop spindles

- AFXWK31DS 64-72.....At-the-Wheel Kit - Black Calipers
- AFXWK31DZ 64-72.....At-the-Wheel Kit - Red Calipers
- AFXSD31DS 64-72.....Manual Kit - Black Calipers
- AFXSD31DZ 64-72.....Manual Kit - Red Calipers
- AFXDC31DS 64-72.....Power Kit - Black Calipers
- AFXDC31DZ 64-72.....Power Kit - Red Calipers

STOCK HEIGHT 4-WHEEL KITS

Stock Height - Non-Staggered Shocks

- AFXWK51CS 64-72.....At-the-Wheel Kit - Black Calipers
- AFXWK51CZ 64-72.....At-the-Wheel Kit - Red Calipers
- AFXSD51CS 64-72.....Manual Kit - Black Calipers
- AFXSD51CZ 64-72.....Manual Kit - Red Calipers
- AFXDC51CS 64-72.....Power Kit - Black Calipers
- AFXDC51CZ 64-72.....Power Kit - Red Calipers

2" DROP 4-WHEEL KITS

2" Drop - Non-Staggered Shocks

- AFXWK51DS 64-72.....At-the-Wheel Kit - Black Calipers
- AFXWK51DZ 64-72.....At-the-Wheel Kit - Red Calipers
- AFXSD51DS 64-72.....Manual Kit - Black Calipers
- AFXSD51DZ 64-72.....Manual Kit - Red Calipers
- AFXDC51DS 64-72.....Power Kit - Black Calipers
- AFXDC51DZ 64-72.....Power Kit - Red Calipers

CUTLASS - 442 SIGNATURE SERIES CONVERSION KITS

X-TRIM DISC BRAKE CONVERSION UPGRADES

Start turning heads with a show finished upper assembly. Manual kits get a chrome plated master cylinder and combination valve with bracket. Power kits also include an 8" dual chrome booster.



Signature
SERIES

X-TRIM UPGRADE FRONT KITS

Uses Existing Drum or Disc Brake Spindles
 AFXSD31CSX..... 64-72 ... Stock Height Manual Kit - Black Calipers
 AFXSD31CZX..... 64-72 ... Stock Height Manual Kit - Red Calipers
 AFXDC31CSX ... 64-72 ... Stock Height Power Kit - Black Calipers
 AFXDC31CZX ... 64-72 ... Stock Height Power Kit - Red Calipers

Includes New 2" Drop Spindles
 AFXSD31DSX.....64-72.....2" Drop Manual Kit - Black Calipers
 AFXSD31DZX.....64-72.....2" Drop Manual Kit - Red Calipers
 AFXDC31DSX.....64-72.....2" Drop Power Kit - Black Calipers
 AFXDC31DZX ... 64-72.....2" Drop Power Kit - Red Calipers

X-TRIM UPGRADE 4-WHEEL KITS

Stock Height - Non-Staggered Shocks
 AFXSD51CSX..... 64-72 ... Stock Height Manual Kit - Black Calipers
 AFXSD51CZX..... 64-72 ... Stock Height Manual Kit - Red Calipers
 AFXDC51CSX ... 64-72 ... Stock Height Power Kit - Black Calipers
 AFXDC51CZX ... 64-72 ... Stock Height Power Kit - Red Calipers

Stock Height - Non-Staggered Shocks
 AFXSD51DSX..... 64-72 ... 2" Drop Manual Kit - Black Calipers
 AFXSD51DZX..... 64-72 ... 2" Drop Manual Kit - Red Calipers
 AFXDC51DSX..... 64-72 ... 2" Drop Power Kit - Black Calipers
 AFXDC51DZX ... 64-72 ... 2" Drop Power Kit - Red Calipers

Signature
SERIES

REAR DISC BRAKE CONVERSION KITS

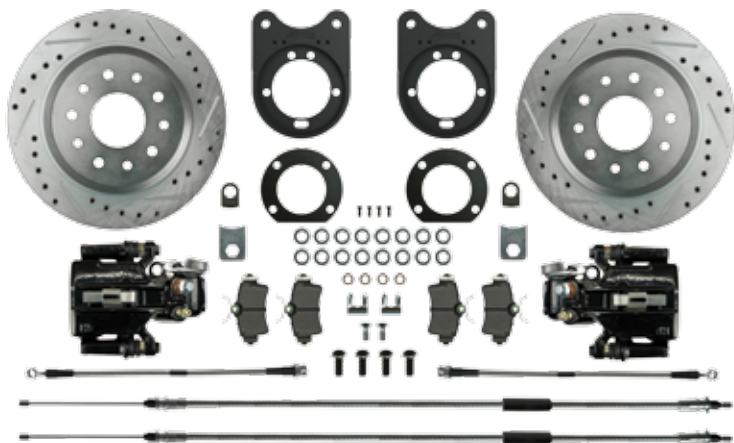

(Kit fits axles with 3-1/8 inch flange only)

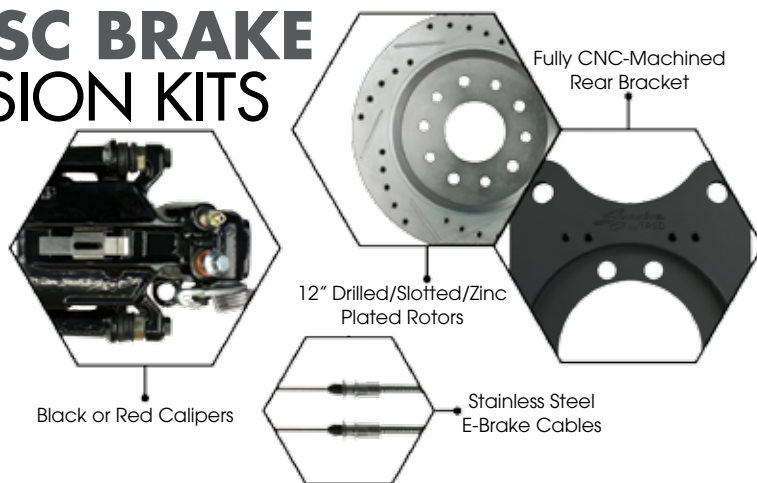

REAR DISC CONVERSION KITS

AFXRD31S 64-77 Rear Disc Conversion - Black
 AFXRD31Z 64-77 Rear Disc Conversion - Red

Disc Brake Conversions require special brake lines that fit your new disc conversion setup. Right Stuff offers "No Brainer" Brake Line Kits that include all components needed from your master cylinder back to your rear wheel cylinder or calipers. They include front brake line kit, front to rear line, rear axle lines & flex hose, & clip set.

See page 218 for your application

No Brainer
BRAKE LINE KITS
 FOR DISC CONVERSIONS

OE Steel Only **Stainless Steel**

PROPORTIONING VALVES

DOES YOUR VALVE
LOOK LIKE THIS?



When upgrading to disc brakes or keeping them stock, make sure your proportioning valve is designed for the brake system that is specific to your vehicle.

PVK71Disc/Drum Proportioning Valve - Brass Finish
 PVK72Disc/Disc Proportioning Valve - Brass Finish
 PVK71C.....Disc/Drum Proportioning Valve - Chrome Finish
 PVK72C.....Disc/Disc Proportioning Valve - Chrome Finish

FULL SIZE OLDSMOBILE BRAKE LINES

FRONT TO REAR LINES

Front to rear brake lines go from the distribution, combination or metering valve along the length of the vehicle to the rear flex hose. Lines are manufactured in 1 or 2 pieces based on factory specifications.

AIN7101



ADD "S" TO PART NUMBER FOR STAINLESS STEEL

- AIN4100.....41-4776/78
- AIN5701 57Super 88
- AIN6101 61Hardtop, 123" Wheel Base
- AIN6102.....61-62.....Convertible, 123" Wheel Base
- AIN6102.....61-62.....Convertible, 123" Wheel Base

- AIN650165Vista Cruiser
- AIN6605 66Delta 88
- AIN6709 67Olds 98, 425 Hardtop
- AIN6905 68Olds 98, Pwr. Drum
- AIN710171-76.....Delta 88, HT
- AIN7700.....77Toronado

FRONT BRAKE LINE KITS

Front brake line kits consist of all brake lines under the hood, including the master cylinder to the distribution, combination or metering valve. The left & right front lines that run to the front flex hoses are also included. Call for individual component pricing. These line kits are for vehicles with factory brake systems.



ADD "S" TO PART NUMBER FOR STAINLESS STEEL

- AKT3700.....37 4 Dr. Sedan 3 Pcs.
- AKT570157 Super 88.....4 Pcs.
- AKT6101 .. 61-62 ... Manual Drum.....3 Pcs.
- AKT6102.. 61-62 ... Power Drum.....3 Pcs.
- AKT650165 Vista Cruiser 4 Pcs.
- AKT6709.....67 Power Drum, Olds 98, 425 4 Pcs.
- AKT7105.. 71-76 ... Power Disc, Delta 88 4 Pcs.

FRONT BRAKE FLEX HOSES

Front flex hoses provide a flexible connection from the body or frame to the front calipers or wheel cylinders as they move during suspension travel. Choose between O.E. rubber or braided stainless steel. All are D.O.T. approved. Hoses are priced each.



FH08

ADD "S" TO PART NUMBER FOR STAINLESS STEEL

- FH80..... 61-69 ... Front Drum
- FH183..... 69-70 ... Front Disc
- FH20.....70 Front Drum
- FH08..... 71-73 ... Front Disc

REAR BRAKE FLEX HOSES

Rear flex hoses carry brake fluid between the body of the car and the rear. Hoses are available in O.E. rubber and braided stainless steel. 'T' blocks are attached whenever factory correct. All of our hoses are D.O.T. approved. Prices are per hose.

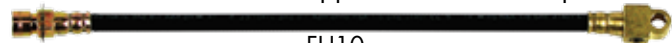

FH10

ADD "S" TO PART NUMBER FOR STAINLESS STEEL

- FH185..... 61-62 ... All Cars
- FH10..... 66-68 ... All Cars
- FH178..... 69-70 ... All Cars
- FH18..... 72-73 ... All Cars Exc. Station Wagon

REAR AXLE BRAKE LINES

Rear axle brake lines include a pair of lines that run across the rear axle housing & connect the wheel cylinders or calipers to the flex hose in the middle of the rear end. Work with original housings that use factory brakes. Modifications such as rear disc brakes or narrowed rear ends will likely require special lines. Call for more information.

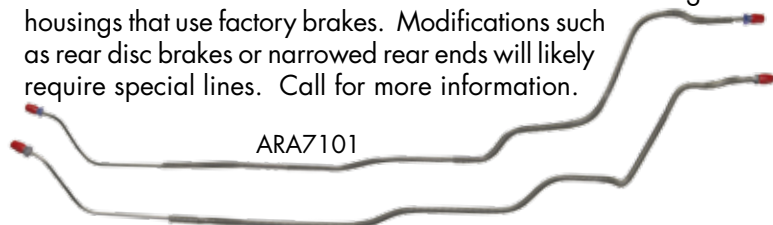

ARA7101

ADD "S" TO PART NUMBER FOR STAINLESS STEEL

- ARA3700 37 All Cars
- ARA4100 41-47 76/78
- ARA5701 57 Super 88
- ARA6101 61-62 All Cars
- ARA6301 63 Super 88
- ARA6501 65 Vista Cruiser
- ARA6605 66 Delta 88
- ARA6709 67 Olds 98, 425 Hardtop
- ARA7101 71-76 Delta 88
- ARA8001 77-82 All Cars

WHEEL CYLINDERS

Wheel cylinders are priced individually. Hardware is not included.

WC11



WC106



- WC106.....60-67.....Left Front, All Exc. Police
- WC107.....60-67.....Right Front, All Exc. Police
- WC11.....60-70.....Right Rear, All Exc. 646 Jester
- WC12.....60-70.....Left Rear, All Exc. 646 Jester
- WC04.....64-66.....Rear, Jester 15/16 Bore
- WC108.....68-70.....Left Front, All Cars & 63-67 Police
- WC109.....68-70.....Right Front, All Cars & 63-67 Police

MAIN FUEL LINES

Main lines carry fuel from the tank in the rear of the car to the fuel pump or rail in the front. They are available in 3/8" and 5/16" tubing based on factory specifications. Multiple piece sets are noted. Call for 1/2" lines.

ADD "S" TO PART NUMBER FOR STAINLESS STEEL

Call Us!37 4 Dr. Sedan
 AGL570157 Super 88, Main Line
 AGL6101 . 61-62 ... 3/8" Main Line
 AGL650165 3/8" Main LineViista Cruiser
 AGL650365 442 Cvt., 3/8" Main, Pass. Side
 AGL670367 3/8" Olds 98, 425 Hardtop
 AGL690169 3/8" Main Line, Delta 88
 AGL750175 3/8" Main Line
 AGL770077 3/8" Main Line, Toronado

RETURN FUEL LINES

Return lines carry excess fuel from fuel pump or fuel filter back to the tank. Not all vehicles were equipped with a return line. They are typically made of 1/4" diameter tubing. Multiple piece sets are noted..

ADD "S" TO PART NUMBER FOR STAINLESS STEEL

AGL6103 ... 61-62 ... 3/16" Return Line
 AGL670467 1/4" Return Line, Olds 98, 425 HT
 AGL690269 1/4" Return Line, Delta 88
 AGL750275 1/4" Return Line, 2-Piece.
 AGL770177 1/4" Return Line, Toronado
 AGL8002 ... 77-82 ... 1/4" Return Line, 116" Wheel Base

VAPOR RETURN LINES

Emission control systems use these 5/16" lines to handle fuel vapors. Some vehicles use a single front to rear line. Others utilize a charcoal canister and require 3 or 4 additional small lines. Multiple piece sets are noted.

ADD "S" TO PART NUMBER FOR STAINLESS STEEL

AGL770277 5/16" Vapor Line, Toronado
 AGL800380 5/16" Vapor Line, Malibu

THERMAL CHOKE LINES

Thermal choke lines carry heat from the exhaust system to the choke coil on the carburetor. Some applications route thru the intake manifold on their way to the carburetor.

ADD "S" TO PART NUMBER FOR STAINLESS STEEL

ACH5701..... 57J2 Choke Line
 ACH5758....57-58.... 4 bbl Choke Control Line

VACUUM WIPER LINES

ADD "S" TO PART NUMBER FOR STAINLESS STEEL

AMV3700 37 Wiper Vacuum Line
 AWW5601 56 From Fuel Pump to Wiper Motor
 AWW5701 57 From Fuel Pump to Wiper Motor

FUEL PUMP TO CARB LINES

Fuel pump to carburetor lines connect the fuel pump to the carburetor. Brass blocks and fittings are included as noted. These lines are intended to work only with factory pump, motor, intake and carburetor combinations.

ADD "S" TO PART NUMBER FOR STAINLESS STEEL

APC5601 56.....324, 4 BBL
 APC5701 57.....J2 Tri-Carb, 3-Piece
 APC6201 62.....394, 4 BBL, No A/C
 APC6602 66-67 8 Cylinder with 4 BBL
 APC6603 66-67 389 Tri-Power, Aluminum Lines,
 No Block, 4-Piece
 APC6803 68-69400, 4 BBL
 APC6801 68-72 8 Cylinder with 2 BBL
 APC68ED 68-72350, Edelbrock 4 BBL
 APC6901 69.....455, Quadrajel, Hurst Olds
 APC6802 70-71 8 Cylinder with 4 BBL
 APC7004 70.....Toronado 455, Quadrajel
 APC7207 72.....350, 4 BBL
 APC7204 72-74with 455
 APC7230 72.....with 442 W30
 APC7705 77.....Toronado
 APC7705 77.....455, 4 BBL
 FPC7903 79-81with 403

VACUUM LINES

ADD "S" TO PART NUMBER FOR STAINLESS STEEL

ABV5701 57 Brake Vacuum Line
 ABV5702 57 Firewall Vacuum Line, 1/2"
 ABV5707 57 Intake Vacuum Feed to Fuel Pump
 ABV5708 57 Olds J2 Power Brake Booster Line
 ABV5709 .. 57 -58 ... Olds J2 Dash Pot Feed on Intake

TRANSMISSION COOLER LINES

Transmission cooler lines are sold as pairs. Be sure to verify the type of transmission in your project before ordering. These lines are intended to work only with factory motor, transmission, and radiator combinations.

ADD "S" TO PART NUMBER FOR STAINLESS STEEL

ATC570157 Super 88
 ATC620162 Hydromatic

DISTRIBUTOR VACUUM LINES

Distributor vacuum lines supply intake vacuum to the distributor for timing control.

ADD "S" TO PART NUMBER FOR STAINLESS STEEL

ADV570157 Super 88
 ADV670767 6 Cyl, 4 BBL

CUTLASS - 442 BRAKE LINE KITS



No Brainer BRAKE LINE KITS FOR DISC CONVERSIONS

When you add disc brakes to your car you are using a new valve that has different size ports pointing in different directions. Even if your lines are brand new or great originals, you are going to have issues trying to use them. Our "No Brainer" Brake Line Kit fixes all these issues from your master cylinder all the way back to your rear wheel cylinders or rear calipers. We give you all the lines to complete the installation. We also include the rear flex hose and a full clip set to install your lines. Extremely discounted prices and great instructions make this kit a No Brainer.

SIMPLIFY YOUR DISC BRAKE CONVERSION INSTALLATION WITH ALL OF THE BRAKE LINES YOU WILL NEED.

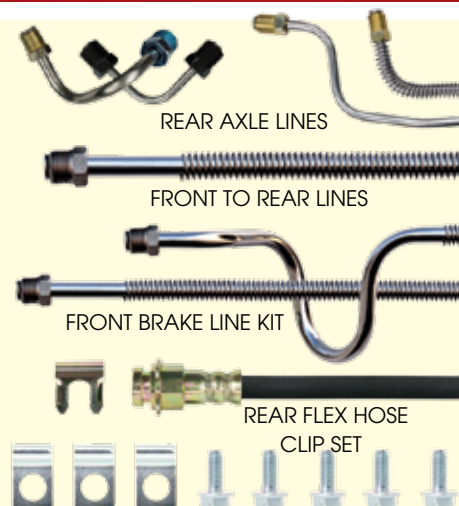

MANUAL - NO VACUUM BOOSTER

FRONT DISC/REAR DRUM LINES

AOM64H2 64-65 OE Steel, Hardtop
 ASM64H2 64-65 Stainless, Hardtop
 AOM64C2 64-65 OE Steel, Convertible
 ASM64C2 64-65 Stainless, Convertible
 AOM66H2 66 OE Steel, Hardtop
 ASM66H2 66 Stainless, Hardtop
 AOM66C2 66 OE Steel, Convertible
 ASM66C2 66 Stainless, Convertible
 AOM67H2 67 OE Steel, Hardtop
 ASM67H2 67 Stainless, Hardtop
 AOM67C2 67 OE Steel, Convertible
 ASM67C2 67 Stainless, Convertible
 AOM68H2 68 OE Steel, Hardtop
 ASM68H2 68 Stainless, Hardtop
 AOM68C2 68 OE Steel, Convertible
 ASM68C2 68 Stainless, Convertible
 AOM69H2 69-72 OE Steel, Hardtop
 ASM69H2 69-72 Stainless, Hardtop
 AOM69C2 69-72 OE Steel, Convertible
 ASM69C2 69-72 Stainless, Convertible

POWER - WITH VACUUM BOOSTER

FRONT DISC/REAR DRUM LINES

AOP64H2..... 64-65 OE Steel, Hardtop
 ASP64H2..... 64-65 Stainless, Hardtop
 AOP64C2..... 64-65 OE Steel, Convertible
 ASP64C2 64-65 Stainless, Convertible
 AOP66H2..... 66 OE Steel, Hardtop
 ASP66H2..... 66 Stainless, Hardtop
 AOP66C2..... 66 OE Steel, Convertible
 ASP66C2 66 Stainless, Convertible
 AOP67H2..... 67 OE Steel, Hardtop
 ASP67H2..... 67 Stainless, Hardtop
 AOP67C2..... 67 OE Steel, Convertible
 ASP67C2 67 Stainless, Convertible
 AOP68H2..... 68 OE Steel, Hardtop
 ASP68H2..... 68 Stainless, Hardtop
 AOP68C2..... 68 OE Steel, Convertible
 ASP68C2 68 Stainless, Convertible
 AOP69H2..... 69-72 OE Steel, Hardtop
 ASP69H2..... 69-72 Stainless, Hardtop
 AOP69C2..... 69-72 OE Steel, Convertible
 ASP69C2 69-72 Stainless, Convertible

4-WHEEL DISC LINES

AOM64H4 64-65 OE Steel, Hardtop
 ASM64H4 64-65 Stainless, Hardtop
 AOM64C4 64-65 OE Steel, Convertible
 ASM64C4 64-65 Stainless, Convertible
 AOM66H4 66 OE Steel, Hardtop
 ASM66H4 66 Stainless, Hardtop
 AOM66C4 66 OE Steel, Convertible
 ASM66C4 66 Stainless, Convertible
 AOM67H4 67 OE Steel, Hardtop
 ASM67H4 67 Stainless, Hardtop
 AOM67C4 67 OE Steel, Hardtop
 ASM67C4 67 Stainless, Convertible
 AOM68H4 68 OE Steel, Hardtop
 ASM68H4 68 Stainless, Hardtop
 AOM68C4 68 OE Steel, Convertible
 ASM68C4 68 Stainless, Convertible
 AOM69H4 69-72 OE Street, Hardtop
 ASM69H4 69-72 Stainless, Hardtop
 AOM69C4 69-72 OE Steel, Convertible
 ASM69C4 69-72 Stainless, Convertible

4-WHEEL DISC LINES

AOP64H4..... 64-65 OE Steel, Hardtop
 ASP64H4..... 64-65 Stainless, Hardtop
 AOP64C4..... 64-65 OE Steel, Convertible
 ASP64C4 64-65 Stainless, Convertible
 AOP66H4..... 66 OE Steel, Hardtop
 ASP66H4..... 66 Stainless, Hardtop
 AOP66C4..... 66 OE Steel, Convertible
 ASP66C4 66 Stainless, Convertible
 AOP67H4..... 67 OE Steel, Hardtop
 ASP67H4..... 67 Stainless, Hardtop
 AOP67C4..... 67 OE Steel, Convertible
 ASP67C4 67 Stainless, Convertible
 AOP68H4..... 68 OE Steel, Hardtop
 ASP68H4..... 68 Stainless, Hardtop
 AOP68C4..... 68 OE Steel, Convertible
 ASP68C4 68 Stainless, Convertible
 AOP69H4..... 69-72 OE Steel, Hardtop
 ASP69H4..... 69-72 Stainless, Hardtop
 AOP69C4..... 69-72 OE Steel, Convertible
 ASP69C4 69-72 Stainless, Convertible

INTERNATIONAL

TBS41IH41-49.. 1/2 & 3/4 Ton, K & KB Models,
Complete Brake & Fuel Set - OE Steel
TBS41IHS ..41-49.. 1/2 & 3/4 Ton, K & KB Models,
Complete Brake & Fuel Set - Stainless
TIN54IH 54 Harvester, 135" WB Front to Rear Brake Line -
OE Steel
TIN54IHS..... 54 Harvester, 135" WB Front to Rear Brake Line -
Stainless
TRA54IH 54 Harvester Rear Axle Lines - OE Steel 2 Pcs.
TRA54IHS 54 Harvester Rear Axle Lines - Stainless 2 Pcs.
TMC54IH..... 54 Harvester Master Cyl. Lines - OE Steel..... 2 Pcs.
TMC54IHS... 54 Harvester Master Cyl. Lines - Stainless 2 Pcs.
TGL54IH 54 Harvester Main Fuel Line - OE Steel
TGL54IHS 54 Harvester Main Fuel Line - Stainless
TPC54IH 54 Harvester Pumo To Carb Line - OE Steel
TPC54IHS 54 Harvester Pumo To Carb Line - Stainless

NASH

JIN3901 39 Front to Rear Brake Line - OE Steel
JIN3901S 39 Front to Rear Brake Line - Stainless
JIN4101 41 Front to Rear Brake Line - OE Steel
JIN4101S 41 Front to Rear Brake Line - Stainless
JGL4101 41 Front to Rear Brake Line - OE Steel
JGL4101S 41 Front to Rear Brake Line - Stainless
JKT4101 41 Front Brake Line Kit - OE Steel 2 Pcs.
JKT4101S 41 Front Brake Line Kit - Stainless 2 Pcs.
JKT3901 39 Front Bake Line Kit - OE Steel 3 Pcs.
JKT3901S 39 Front Bake Line Kit - Stainless 3 Pcs.
JPC3901 39 Lafayette Pump to Carb. - OE Steel
JPC3901S 39 Lafayette Pump to Carb. - Stainless
JRA3901 39 Rear Axle Brake Lines - OE Steel 2 Pcs.
JRA3901S 39 Rear Axle Brake Lines - Stainless 2 Pcs.
JRA4101 41 Rear Axle Brake Lines - OE Steel 2 Pcs.
JRA4101S 41 Rear Axle Brake Lines - Stainless 2 Pcs.
JPC4101 41 Fuel Pump to Carb Line - OE Steel
JPC4101S 41 Fuel Pump to Carb Line - Stainless
JWV4101 41 Vacuum Wiper Line - OE Steel
JWV4101S 41 Vacuum Wiper Line - Stainless
JPC4201 42 600 Pump to Carb Line - OE Steel
JPC4201S 42 600 Pump to Carb Line - Stainless
JDV4201 42 600 Vacuum Line - OE Steel
JDV4201S 42 600 Vacuum Line - Stainless
JPC4701 47 Ambassador Pump to Carb. 6cyl. - OE Steel
JPC4701S 47 Ambassador Pump to Carb. 6cyl. - Stainless
JRA6701 67-68... Ambassador - OE Steel
JRA6701S..... 67-68... Ambassador - Stainless

MG

IBS6900 69..... Complete Brake Line Set - OE Steel..... 9 Pcs.
IBS6900S 69..... Complete Brake Line Set - Stainless..... 9 Pcs.

PACKARD

IBS3701 37 ... Complete Brake Set - OE Steel..... 6 Pcs.
IBS3701S ... 37 ... Complete Brake Set - Stainless..... 6 Pcs.
IGL3701 37 ... Main Fuel Line - OE Steel..... 1 Pc.
IGL3701S ... 37 ... Main Fuel Line - Stainless 1 Pc.
IBS4101 41 ... Complete Brake Set, 110"WB - OE Steel.... 6 Pcs.
IBS4101S ... 41 ... Complete Brake Set, 110"WB - Stainless.... 6 Pcs.
IBS4102 41 ... Complete Brake Set, 120"WB - OE Steel.... 6 Pcs.
IBS4102S ... 41 ... Complete Brake Set, 120"WB - Stainless.... 6 Pcs.
ICH4101 41 ... Choke Tube - OE Steel..... 1 Pc.
ICH4101S ... 41 ... Choke Tube - Stainless..... 1 Pc.
ICV4101 41 ... Conv. Top Vacuum Lines - OE Steel 8 Pcs.
ICV4101S... 41 ... Conv. Top Vacuum Lines - Stainless..... 8 Pcs.
IDV4101 41 ... Distributor Vacuum Line - OE Steel 1 Pc.
IDV4101S... 41 ... Distributor Vacuum Line - Stainless..... 1 Pc.
IGL4101 41 ... 5/16" Main Fuel Line, 110"WB - OE Steel
IGL4101S ... 41 ... 5/16" Main Fuel Line, 110"WB - Stainless
IGL4102 41 ... 5/16" Main Fuel Line, 120"WB - OE Steel.. 2 Pc.
IGL4102S ... 41 ... 5/16" Main Fuel Line, 120"WB - Stainless. 2 Pc.
IPC4101 41 ... Fuel Pump to Carb. Line - OE Steel..... 2 Pcs.
IPC4101S... 41 ... Fuel Pump to Carb. Line - Stainless 2 Pcs.
ICV5401 54 ... Convertible, Along Floorboard - OE Steel ... 6 Pcs.
ICV5401S... 54 ... Convertible, Along Floorboard 6 Pcs.

STUDEBAKER

JBS5901 59 Silver Hawk Brake Set - OE Steel..... 6 Pcs.
JBS5901S 59 Silver Hawk Brake Set - Stainless..... 6 Pcs.
JRA6401 64 Avanti Rear Axle Lines - OE Steel 2 Pcs.
JRA6401S 64 Avanti Rear Axle Lines - Stainless..... 2 Pcs.
JIN6401 64 Avanti Front to Rear Brake - OE Steel 2 Pcs.
JIN6401S 64 Avanti Front to Rear Brake - Stainless 2 Pcs.
JGL6403 64 Avanti 3/8" Main Fuel - OE Steel..... 2 Pcs.
JGL6403S 64 Avanti 3/8" Main Fuel - Stainless..... 2 Pcs.
JGL6404 64 Avanti 1/4" Return Fuel - OE Steel 2 Pcs.
JGL6404S 64 Avanti 1/4" Return Fuel - Stainless 2 Pcs.
JKT6401 64 Avanti Front Brake Kit - OE Steel 3 Pcs.
JKT6401S ... 64 Avanti Front Brake Kit - Stainless..... 3 Pcs.
JTC6401 64 Avanti Trans. Cooler - OE Steel 3 Pcs.
JTC6401S 64 Avanti Trans. Cooler - Stainless 3 Pcs.
JPC6403 64 Avanti Pump to Carb Set - OE Steel 3 Pcs.
JPC6403S 64 Avanti Pump to Carb Set - Stainless 3 Pcs.

NISSAN 240Z

IBS7201 71-72 .. Complete Brake & Fuel Set - OE Steel .. 13 Pcs.
IBS7201S .. 71-72 .. Complete Brake & Fuel Set - Stainless... 13 Pcs.

NISSAN 260Z

IBS7201 71-72 .. Complete Brake & Fuel Set - OE Steel .. 13 Pcs.
IBS7201S .. 71-72 .. Complete Brake & Fuel Set - Stainless... 13 Pcs.

KAISER

IBS5201 52 ... Delux, 4D, Complete Brake Set - OE Steel ... 6Pc.
IBS5201S ... 52 ... Delux, 4D, Complete Brake Set - Stainless.... 6Pc.

FRONT BRAKE LINE KITS

Front brake line kits consist of all brake lines under the hood. This includes the master cylinder to the distribution, combination or metering valve. The left and right front lines that run to the front flex hoses are also included. Call for individual component pricing. These line kits are for vehicles with factory brake systems.

ADD "S" TO PART NUMBER FOR STAINLESS STEEL

JKT6001	60	Manual Disc	3 Pcs.
JKT6501	65-66	Power Disc, Marlin	5 Pcs.
JKT6801	68-69	Power Disc Brakes	5 Pcs.
JKT6802	68-69	Manual Drum Brakes	5 Pcs.
JKT6803	68-69	Power Drum	5 Pcs.
JKT6901	69	Rambler, Power Disc	7 Pcs.
JKT7001	70	Power Disc	5 Pcs.
JKT7003	70	Power Drum	5 Pcs.
JKT7004	70	Power Disc, Rebel	5 Pcs.
JKT7005	70	Power Disc, Ambassador	5 Pcs.
JKT7002	70-72	Manual Drum Brakes	5 Pcs.
JKT7104	71-72	Power Drum	5 Pcs.
JKT7101	71-74	Power Disc Brakes	5 Pcs.
JKT7102	71	Manual Drum, Gremlin	5 Pcs.
JKT7201	72	Power Drum	5 Pcs.
JKT7202	72-74	Manual Disc, Gremlin	5 Pcs.
JKT7203	72-74	Power Drum	5 Pcs.
JKT7204	72-74	Power Disc, Gremlin	5 Pcs.
JKT7603	76	Manual Disc, Gremlin	5 Pcs.

FRONT TO REAR BRAKE LINES

Front to rear brake lines go from the distribution, combination or metering valve along the length of the vehicle to the rear flex hose. Manufactured in 1 or 2 pieces based on factory specs.

ADD "S" TO PART NUMBER FOR STAINLESS STEEL

JIN6501	65-66	Marlin with Power Disc	
JIN6801	68-70	AMX with Disc Brakes	2 Pcs.
JIN6802	68-70	AMX with Drum Brakes	
JIN6803	68-70	Javelin with Disc Brakes	2 Pcs.
JIN6804	68-70	Javelin with Drum Brakes	
JIN6901	69	SC Rambler	2 Pcs.
JIN7001	70	AMC Rebel	
JIN7201	72	Gremlin with Drum Brakes	
JIN7202	72	Gremlin with Power Disc	
JIN7101	71-74	Javelin or AMX, All Cars	
JIN7203	72	Gremlin with Manual Disc	

FRONT BRAKE FLEX HOSES

Front flex hoses provide a flexible connection from the body or frame to the front calipers or wheel cylinders as they move during suspension travel. O.E. rubber. All of our hoses are D.O.T. approved. Hoses are priced individually.

FH190

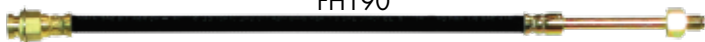

FH188	67-70	Front Disc, AMX, Javelin, Hornet, Rebel
FH190	71-74	Front Disc, AMX
FH189	73-76	Front Disc, Gremlin

REAR AXLE BRAKE LINES

Rear axle brake lines include a pair of lines that run across the rear axle housing. These lines connect the wheel cylinders or calipers to the flex hose in the middle of the rear end. These lines work with original housings that use factory brakes. Modifications such as rear disc brakes or narrowed rear ends will likely require special lines. Call for more information.

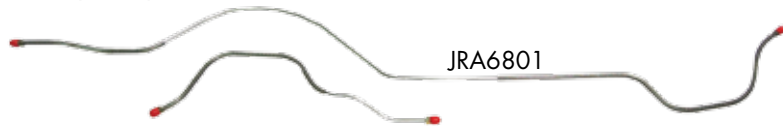

ADD "S" TO PART NUMBER FOR STAINLESS STEEL

JRA4601	46	Ambassador	2 Pcs.
JRA6401	64-69	All 6 Cylinder Models	2 Pcs.
JRA6501	65-66	Marlin	2 Pcs.
JRA6801	68-70	All V8 Models	2 Pcs.
JRA6901	69	SC/ Rambler, Power Disc	2 Pcs.
JRA6903	69-70	Ambassador with Front Drum	2 Pcs.
JRA7001	70	AMC Rebel, 5/16"	2 Pcs.
JRA7101	71-74	All Models	2 Pcs.
JRA7601	76	Pacer	2 Pcs.

MAIN FUEL LINES

Main lines carry fuel from the tank in the rear of the car to the fuel pump or rail in the front. They are available in 3/8" and 5/16" tubing based on factory specifications. Return lines are usually made in 3/16". Individual runs with multiple sections are noted. Call for 1/2" lines.

ADD "S" TO PART NUMBER FOR STAINLESS STEEL

JGL6401	64-69	5/16" Rambler, Main Fuel Line
JGL6402	64-69	5/16" Rambler V-8, Main Fuel Line
JGL6702	67-68	5/16" Rebel, Main Line
JGL6801	68-69	5/16" AMX, Main Line
JGL6803	68-69	3/8" AMX Main Line
JGL6802	68-69	5/16" Javelin 8 Cylinder, Main Line
JGL6803	68-69	3/8" AMX, Main Line
JGL7001	70	5/16" AMX, Main Line
JGL7002	70	3/16" AMX, Vapor Line
JGL7003	70	5/16" Javelin 8 Cylinder, Main Line
JGL7004	70	5/16" AMC Rebel, Mail Line
JGL7102	71-72	3/16" Javelin or AMX with V8, Return
JGL7101	71-74	5/16" Javelin or AMX with V8, Main
JGL7201	72	5/16" Gremlin with V8 Main
JGL7302	73-74	3/16" Javelin or AMX with V8, Return
JGL7305	73-75	5/16" Gremlin Main Fuel

FUEL TANK OVERFLOW LINES

Overflow tubes handle excess fuel when filled over capacity.

JFV6701	67	Marlin, 1/2" Tube
JFV6701	67-70	Rebel, 1/2" Tube
JFV6701	67-73	Ambassador, 1/2" Tube
JFV6701	71-73	Matador

BRAKE CALIPERS



Rebuilt calipers do not include pads or hardware. Core charges apply as noted.

BC1665-70..... Bendix 4 Piston Caliper,

DISC BRAKE CALIPER LINES

Front disc caliper lines connect the front flex hoses to the calipers. Typically used on 4 piston calipers in the late 1960's. Several fitting sizes were available from the factory. Verify fitting sizes before ordering, rebuilt calipers may not match the originals.

ADD "S" TO PART NUMBER FOR STAINLESS STEEL

JFB600160 Left Front

JFB6002660 Right Front

JFB6804 ... 68-70 ... Disc Brake Front Caliper Line Set for Bendix 4 Piston Calipers



THERMAL CHOKE LINES

Thermal choke lines carry heat from the exhaust system to the choke coil on the carburetor. Some applications route thru the intake manifold on their way to the carburetor.

ADD "S" TO PART NUMBER FOR STAINLESS STEEL

JCH6102 60-62 OHV, 1 BBL, Manual

JCH6101 61-63 OHV, 1 BBL, Automatic

JCH650265 6 Cyl, 232 ci, 2 BBL

JCH6501 65-66 V8, 4BBL 2 Pcs.

JCH6701 67-69 8 Cylinder with 4 BBL, AFB Carb.

JCH700270 304 with 2 BBL

JCH7004 70-71 V-8 with 4 BBL

TRANSMISSION VACUUM LINES

Trans vacuum lines connect automatic trans to intake vacuum.

ADD "S" TO PART NUMBER FOR STAINLESS STEEL

JTV680268 6 Cylinder, Ambassador

JTV6801 ... 68-71 ... 8 Cylinder, with Borg-Warner Auto

JTV7201 ... 72-74 ... 8 Cylinder, with 727

VACUUM WIPER LINES

ADD "S" TO PART NUMBER FOR STAINLESS STEEL

JWV650165-66.... 8 Cylinder

JWV6801 68 8 Cylinder

JWV690169-70.... 8 Cylinder

JWV7001 70 Javelin.....

OIL LINES

ADD "S" TO PART NUMBER FOR STAINLESS STEEL

JOL5201... 52-56 ... Rocker Oil Lines, Engine Block to Head Ambassador

JOL5801... 58-62 ... AMC Rambler Oil Filter Lines 3-Pc

TRANSMISSION COOLER LINES

Transmission cooler lines are sold as pairs. Be sure to verify the type of transmission in your project before ordering. These lines are intended to work only with factory motor, transmission, and radiator combinations.

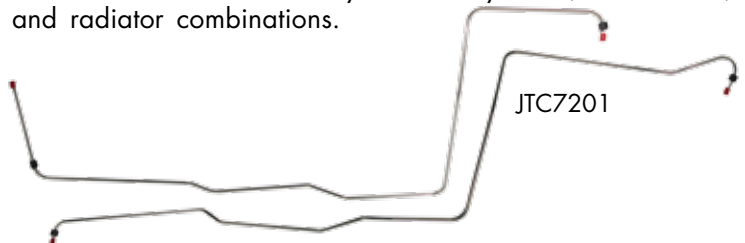

ADD "S" TO PART NUMBER FOR STAINLESS STEEL

JTC680168 AMX with Borg-Warner HD Trans, without Fittings at Radiator

JTC6701 ... 68-71 ... AMC Borg-Warner Heavy Duty Auto, with Clamp On Hose & Fittings

JTC6702... 68-71 ... AMC Borg-Warner Heavy Duty Auto, with Screw in Hoses at Radiator

JTC690169 AMX with Borg-Warner HD Trans, with Fittings at Radiator

JTC720672 6 Cylinder Gremlin

JTC7201 ... 72-74 .. with 727, 360, 401

DISTRIBUTOR VACUUM LINES

Distributor vacuum lines supply intake vacuum to the distributor for timing control.

ADD "S" TO PART NUMBER FOR STAINLESS STEEL

JDV6401 64 196 ci, 6 Cylinder, 1 BBL

JDV6501 65-66 V-8, 4 BBL

JDV6701 67 V-8, 2 BBL

JDV6702 67 V-8, 4 BBL

JDV6901 69 V-8, 4 BBL

JDV7001 70 V-8, 2 BBL

FUEL PUMP TO CARB LINES

Fuel pump to carburetor lines connect the fuel pump to the carburetor. Brass blocks and fittings are included as noted. These lines are intended to work only with factory pump, motor, intake and carburetor combinations. If your system is not 100% stock, call us to discuss available options..

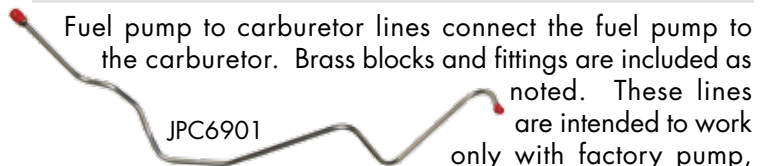

ADD "S" TO PART NUMBER FOR STAINLESS STEEL

JPC6401... 64-65 ... Rambler, 6 Cylinder 196ci, 1 BBL

JPC6402... 64-65 ... Rambler, 6 Cylinder Flathead

JPC6501... 65-66 ... V-8, 4 BBL with Electric Wipers

JPC6701 ... 67-68 ... V-8, 4 BBL, Pump-Carb.

JPC690169 V-8, 4 BBL, Pump-Carb.

JPC700270 V-8, 2 BBL, Upper Line

JPC7001... 70-71 ... V-8, 2 or 4 BBL, w/Elec. Wipers, Lower

JPC7004... 70-74 ... Fuel Filter Vacuum Line

JPC7005... 70-74 ... V-8, 4 BBL, Upper Line

JPC7201... 72-74 ... V-8, 4 BBL, Lower Line, 1-Pc

JPC7301... 71-73 ... Gremlin, 258 6 cyl. Manual Drum

JPC7306... 73-74 ... V-6, All

FORD FRONT BRAKE CONVERSIONS

**STREET
SERIES**

FRONT DISC BRAKE CONVERSION KITS

FRONT CONVERSIONS INCLUDE:

- 11" Rotors
- New 4-Piston Calipers
- Caliper Brackets
- Organic Pads
- Backing Plates
- Flex Hoses & Clips
- Backing Plates
- Flex Hoses & Clips
- Banjo Bolts & Copper Washers
- Dust Caps
- Castle Nuts & Pins
- Washers
- Grease Seals
- Bearings
- Spindle Gaskets
- Steering Arm Bolts
- Master Cylinder
- Adjustable Valve

Right Stuff disc conversions are the most complete kits in the industry at the right price. High quality components, professional packaging, and after-sale support by "hands-on" technicians create an unbeatable value. Consider one of our complete brake line packages for a care-free installation.

We only carry front conversions for factory V8 cars. If you have a manual transmission, power conversions may present interference between your clutch linkage and brake booster.

Fits 1964.5-69 Mustang, 1963-69 Falcon, 1964.5-69 Fairlane/Ranchero/Comet/Cyclone, 1967-69 Cougar, 1968-69 Torino/Montego

WORKS WITH 14" FACTORY & LARGER WHEELS

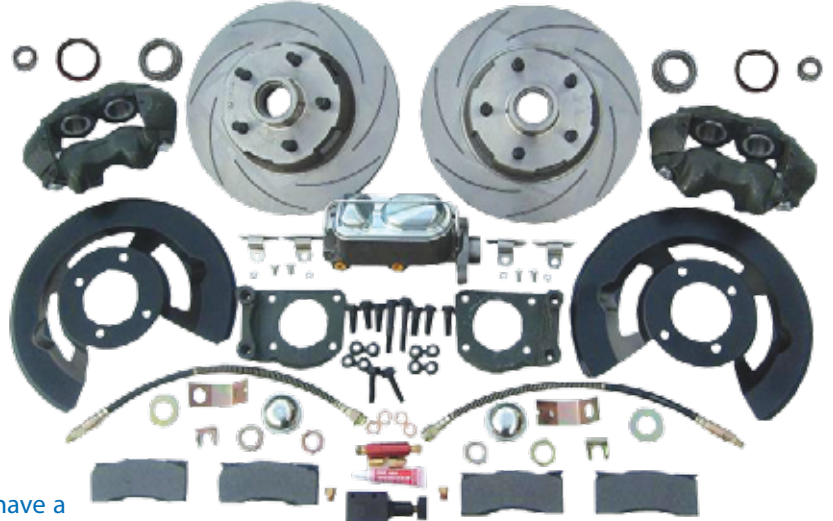

Kits Starting

STOCK HEIGHT MANUAL KITS

ZSD6405..... 64-66Manual Disc Conversion Package
ZSD6708..... 67-69Manual Disc Conversion Package

STOCK HEIGHT POWER KITS

ZDC6405 64-66Power Disc Conversion Package
ZDC6708 67-69Power Disc Conversion Package

AXLE FLANGE DIAGRAMS

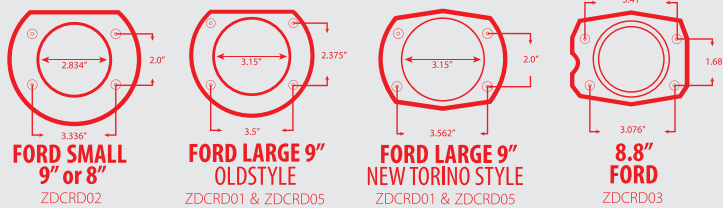

No Brainer
BRAKE LINE KITS
DESIGNED FOR DISC CONVERSIONS

OE Steel Only

Stainless Steel

Call today for your application



FORD REAR BRAKE CONVERSIONS

**STREET
SERIES**

REAR DISC BRAKE CONVERSION KITS

REAR CONVERSIONS INCLUDE:

- 11" Rotors
- Flex Hoses
- New Loaded Calipers
- Weld-On Hose Brackets
- Caliper Brackets & Spacers
- Hardware

Right Stuff disc conversions include high quality components, professional packaging, and superior tech support. *Verify the axle flange measurements for your kit.*

Available Emergency Brakes - All of our Ford rear conversions are available with or without an emergency brake system. The mechanism is built into the rear calipers on kit with an emergency brake. Generic cables are provided to tie into your existing cable system. Modification may be required.

Our rear conversions are compatible with aftermarket rear ends like Moser, Strange or Currie. Make sure your aftermarket axle tube ends match our listing before ordering.

WORKS WITH 15" AND LARGER WHEELS

6-5/16" INSIDE ROTOR DIAMETER - 2.78" CENTER HOLE

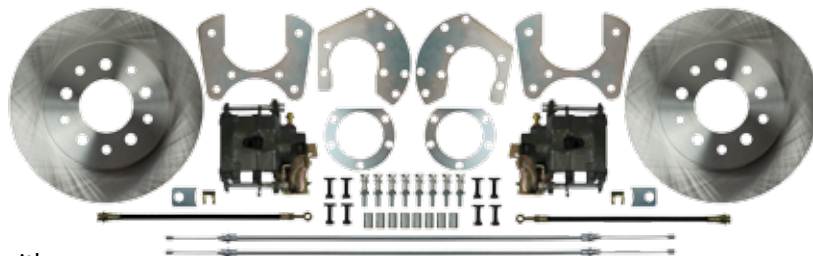

ATTENTION Before you order, be sure to measure the axle flange on your vehicle.

REAR KITS WITH E-BRAKE

- ZDCRD01 9" Large Bearing, Old Style
- ZDCRD01 9" Large Bearing, New/Torino Style
- ZDCRD02 9" Small Bearing
- ZDCRD02 8" Small Bearing
- ZDCRD03 8.8" (Requires 5-Lug Axles)
- ZDCRD04 8.8" with 5-Lug Axles Included
- ZA05 79-93 5-Lug Axles (pr) Convert 4-Lug Rear to 5-Lug

REAR KITS WITHOUT E-BRAKE

- ZDCRDM1 9" Large Bearing, Old Style
- ZDCRDM1 9" Large Bearing, New/Torino Style
- ZDCRDM2 9" Small Bearing
- ZDCRDM2 8" Small Bearing
- ZDCRDM3 8.8" (Requires 5-Lug Axles)
- ZDCRDM4 8.8" with 5-Lug Axles Included
- ZA05 79-93 5-Lug Axles (pr) Convert 4-Lug Rear to 5-Lug

FRONT DISC BRAKE CONVERSION UPGRADES

**STREET
SERIES**

SHOW'N GO UPGRADE TRIM KITS

Rear Disc Brake Conversion Kits include upgraded drilled slotted rotors with zinc plating, powder coated calipers in red or black, and braided stainless hoses.



REAR KITS WITH E-BRAKE

- ZDCRD01S 9" Large Bearing, Old Style - Black
- ZDCRD01Z 9" Large Bearing, Old Style - Red
- ZDCRD01S 9" Large Bearing, New/Torino Style - Black
- ZDCRD01Z 9" Large Bearing, New/Torino Style - Red
- ZDCRD02S 9" Small Bearing - Black
- ZDCRD02Z 9" Small Bearing - Red
- ZDCRD02S 8" Small Bearing - Black
- ZDCRD02Z 8" Small Bearing - Red
- ZDCRD03S 8.8" (Requires 5-Lug Axles) - Black
- ZDCRD03Z 8.8" (Requires 5-Lug Axles) - Red
- ZDCRD04S 8.8" with 5-Lug Axles Included - Black
- ZDCRD04Z 8.8" with 5-Lug Axles Included - Red
- ZA05 79-93 5-Lug Axles Convert 4-Lug Rear to 5-Lug (pr)

REAR KITS WITHOUT E-BRAKE

- ZDCRDM1S 9" Large Bearing, Old Style - Black
- ZDCRDM1Z 9" Large Bearing, Old Style - Red
- ZDCRDM1S 9" Large Bearing, New/Torino Style - Black
- ZDCRDM1Z 9" Large Bearing, New/Torino Style - Red
- ZDCRDM2S 9" Small Bearing - Black
- ZDCRDM2Z 9" Small Bearing - Red
- ZDCRDM2S 8" Small Bearing - Black
- ZDCRDM2Z 8" Small Bearing - Red
- ZDCRDM3S 8.8" (Requires 5-Lug Axles) - Black
- ZDCRDM3Z 8.8" (Requires 5-Lug Axles) - Red
- ZDCRDM4S 8.8" with 5-Lug Axles Included - Black
- ZDCRDM4Z 8.8" with 5-Lug Axles Included - Red
- ZA05 79-93 5-Lug Axles (pr) Convert 4-Lug Rear to 5-Lug

FORD SIGNATURE SERIES CONVERSIONS



FRONT "COBRA" DISC BRAKE CONVERSION KITS

U.S.A. Made **TIMKEN** Bearings

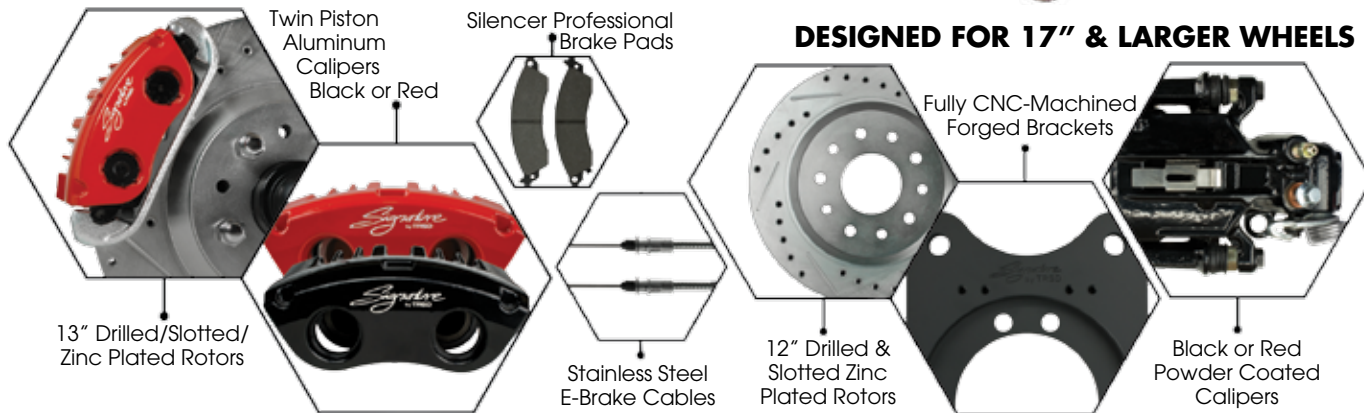

FRONT CONVERSIONS INCLUDE:

- 13" Drilled & Slotted Zinc Plated Rotors
- Twin Piston Aluminum Calipers
- Premium Brake Pads

These Cobra Brake Upgrades will bolt directly on a 94-04 Mustang GT. Also can be used on 79-93 vehicles if SN95 spindles are purchased separately. (Spindles currently not available through The Right Stuff).

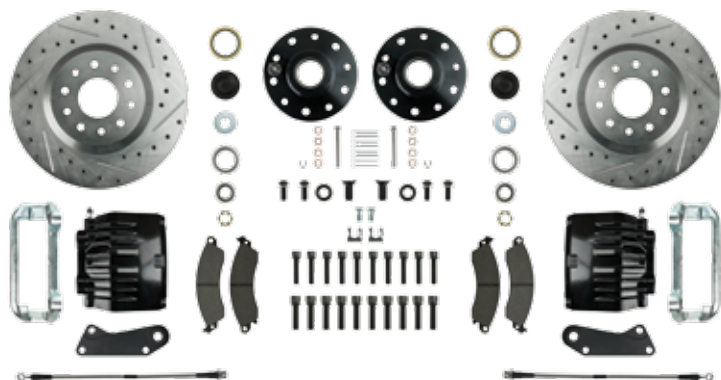

Bold looks define the Signature Series line of brake kits. Large diameter zinc plated rotors, powder coated calipers, fully machined caliper brackets, & braided stainless brake hoses. Only premium quality components make the grade. We back every kit with industry leading technical support. Signature Series kits are amazing brakes at a great price.

FRONT "COBRA" BRAKE KITS

- ZRK94S94-04..... Cobra Brake Kit - Black Calipers
- ZRK94Z94-04..... Cobra Brake Kit - Red Calipers
- ZRK94S79-93*..... Cobra Brake Kit - Black Calipers
- ZRK94Z79-93*..... Cobra Brake Kit - Red Calipers
- * 1979-93 vehicles require SN95 spindles



REAR "COBRA" DISC BRAKE CONVERSION KITS

REAR CONVERSIONS INCLUDE:

- 12" Drilled & Slotted Zinc Plated Rotors
- 5 x 4.75" & 5 x 4.5" Bolt Pattern
- Premium Brake Pads
- Intergrated Parking Brake

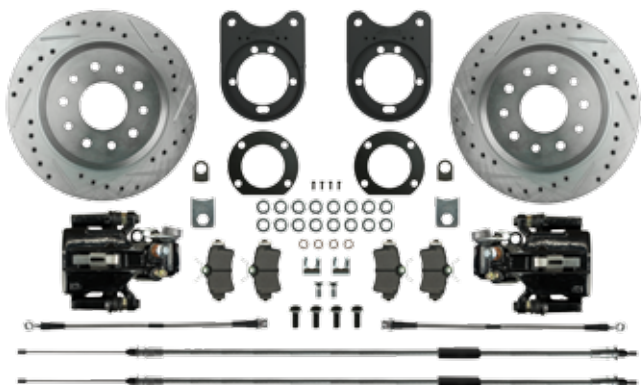

AXLE FLANGE DIAGRAMS

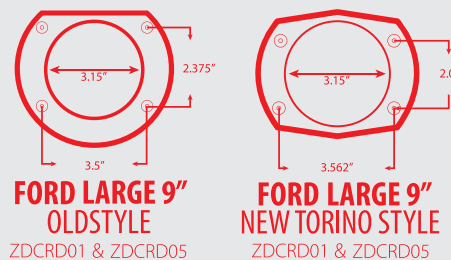

REAR "COBRA" BRAKE KITS

- ZDCRD31S9" Ford Large Bearing, Old/New - Black Calipers
- ZDCRD31Z9" Ford Large Bearing, Old/New - Red Calipers

FRONT BRAKE LINE KITS

Front brake line kits consist of all brake lines under the hood. This includes the master cylinder to the distribution, combination or metering valve. The left and right front lines that run to the front flex hoses are also included. Call for individual component pricing. Kits are for vehicles with factory brake systems.

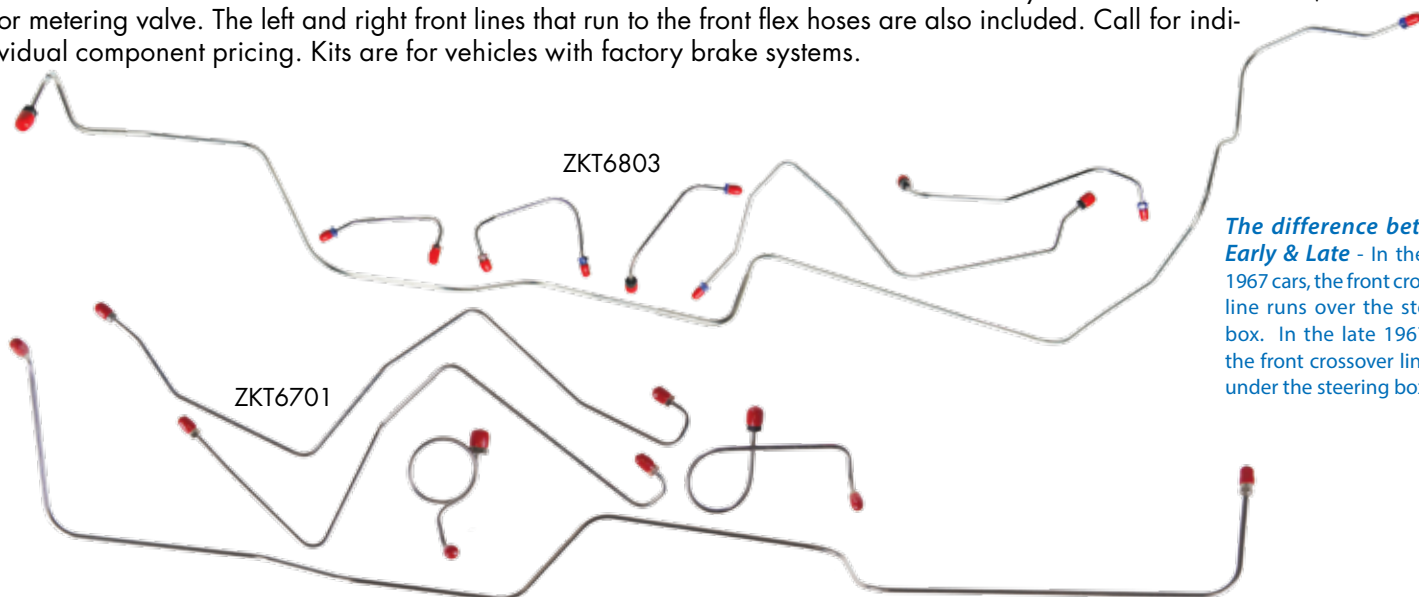

The difference between Early & Late - In the early 1967 cars, the front crossover line runs over the steering box. In the late 1967 cars, the front crossover line runs under the steering box.

ADD "S" TO PART NUMBER FOR STAINLESS STEEL

ZKT6401 .. 64-65... Standard Drum	3 Pcs.
ZKT6402 .. 64-65... Power Drum	3 Pcs.
ZKT6503 .. 65-66... Front Disc	6 Pcs.
ZKT6601 66 Standard Drum	3 Pcs.
ZKT6602 66 Power Drum	3 Pcs.
ZKT6701 67 Std. Drum, Before 2/1/67	5 Pcs.
ZKT6702 67 Standard Drum, After 2/1/67 ..	5 Pcs.
ZKT6703 67 Front Disc, Before 2/1/67	6 Pcs.
ZKT6704 67 Front Disc, Late	6 Pcs.
ZKT6705 67 Power Drum, Before 2/1/67,	
RF Over Column	5 Pcs.
ZKT6706 67 Power Drum, After 2/1/67,	
RF Under Column	5 Pcs.
ZKT6801 .. 68-69... Standard Drum	5 Pcs.

ZKT6802 .. 68-69... Power Drum	5 Pcs.
ZKT6803 .. 68-69... Front Disc	6 Pcs.
ZKT6901 69 Boss 429, Power Disc	6 Pcs.
ZKT7001 70 Standard Drum	5 Pcs.
ZKT7002 70 Power Disc	4 Pcs.
ZKT7003 70 Boss 429, Power Disc	4 Pcs.
ZKT7102 .. 71-72... Front Disc	5 Pcs.
ZKT7101 .. 71-73... Front Drum	5 Pcs.
ZKT7302 73 Front Disc	5 Pcs.
ZKT7801 .. 76-78... Front Disc	4 Pcs.
ZKT8201 82 Pwr. Disc Front Brake Line Kit ..	5 Pcs.
ZKT8501 .. 84-86... Front Disc	5 Pcs.
ZKT8701 .. 87-93... Front Disc	5 Pcs.
ZKT9001 92 4 cyl, Front Disc, Rear Drum ..	5 Pcs.
ZKT9608 .. 96-98... Cobra, SVT, 4W Disc, ABS	6 Pcs.

FRONT TO REAR BRAKE LINES

Front to rear brake lines go from the distribution, combination or metering valve along the length of the vehicle to the rear flex hose. Lines are manufactured in 1 or 2 pieces based on factory specs.

ADD "S" TO PART NUMBER FOR STAINLESS STEEL

ZIN6401 64-66Front Drum, Factory Single Exhaust	
ZIN6402 64-66Front Drum, Factory Dual Exhaust	
ZIN6403 64-66Front Disc, Factory Single Exhaust	
ZIN6404 64-66Front Disc, Factory Dual Exhaust	
ZIN6701 67Front Drum, Before 2/1/67	
ZIN6702 67Front Disc, Before 2/1/67, 2-Piece	
ZIN6703 67Front Drum, After 2/1/67	
ZIN6704 67Front Disc, After 2/1/67, 2-Piece	
ZIN6706 67Front Disc, with Prop Valve,	
Under Distribution Block	

ZIN6801 68-69All	
ZIN7001 70Front Drum Brakes	
ZIN7002 70Front Disc Brakes	
ZIN7101 71Front Drum Brakes	
ZIN7102 71Front Disc Brakes	
ZIN7201 72-73Front Drum Brakes	
ZIN7202 72-73Front Disc Brakes	
ZIN7801 76-78Front Disc Brakes	
ZIN8501 84-86Front Disc Brakes	
ZIN8502 85Disc/Drum, 4 cyl, Single Exhaust	
ZIN8201 82Front to Rear Brake Line	
ZIN8701 87-93Front Disc Brakes	
ZIN9201 87-93LX, Disc/Drum	
ZIN9608 96-98Cobra, SVT, 4W Disc, ABS, 2-Piece.	

MUSTANG BRAKE LINES

REAR AXLE BRAKE LINES



Rear axle brake lines include a pair of lines that run across the rear axle housing. These lines connect the wheel cylinders or calipers to the flex hose in the middle of the rear end. These lines work with original housings that use factory brakes. Modifications such as rear disc brakes or narrowed rear ends will likely require special lines. Call for more information.

ADD "S" TO PART NUMBER FOR STAINLESS STEEL

- ZRA6401....64-66... 6 Cylinder
- ZRA6402....64-66... 8" with Fact.Single Exhaust
- ZRA6403....64-66... 8" or 9", with Dual Exhaust
- ZRA6404....64-65... Shelby 9" with Track Package
- ZRA6703.....67 9", 28 Spline Axles
- ZRA6701....67-69... 6 Cylinder
- ZRA6702....67-69... 8"
- ZRA6801.....68 9", 28 Spline Axles
- ZRA6802....68-69... 9" (CJ or Boss), 31 Spline
- ZRA6901.....69 9", 28 Spline Axles

- ZRA7002.....70 8"
- ZRA7003.....70 9"
- ZRA7102....71-73... 8" or 9"
- ZRA7601.....76 before 7/12/76, 6 Cylinder
- ZRA7801....76-78... All Cars, After 7/12/76
- ZRA8401....84-86... SVO Rear Disc
- ZRA8501....84-86... All Cars
- ZRA8701....87-93... All Cars
- ZRA9001....90-92... Drum Brakes
- ZRA9608....96-98... Cobra, SVT, 4W Disc, ABS

DISC BRAKE CALIPER LINES

Front disc caliper lines connect the front flex hoses to the calipers. They were typically used on 4 piston calipers in the late 1960's. Please verify fitting sizes before ordering as rebuilt calipers may not match the originals



- ZFC640165-67... Caliper Crossover Lines, Kelsey-Hayes
4 Piston - OE Steel, 2-Piece
- ZFC6401S...65-67... Caliper Crossover Lines, Kelsey-Hayes
4 Piston - Stainless, 2-Piece

GENERIC LINE CLIP SETS

These sets consist of generic clips that get the job done. See separate clips on pages 284-285.



- ZCS640164-67..... Brake & 1 Pc Fuel Line
- ZCS670167-70..... Brake & 2-Piece 5/16" Fuel Line
- ZCS670367-70..... Brake & 2-Piece 3/8" Fuel Line
- ZCS760176 Brake Clip Set
- ZCS760376 5/16" Main, 1/4" Return Fuel Set

FLEX HOSE C-CLIP

Hose hardware is used to secure flex hoses to various parts of the vehicle.



- FHC01 Correct Gold Cadmium Plated C Clips

FACTORY LINE CLIP SETS

Brake line clip sets contain all the clips needed to fasten the brake tubes to the fram or body of the car.



- ZCS6501 ...65-66... 6 Cylinder
- ZCS6502 ...65-66... 8 Cyl, Drum
- ZCS6503 ...65-66... 8 Cyl, Disc
- ZCS670467 6 Cyl, 1 Pc Front to Rear
- ZCS670667 6 Cyl, 2 Pc Front to Rear, Convertible
- ZCS670767 6 Cyl, 2 Pc Front to Rear, Hardtop
- ZCS670567 8 Cyl, 1 Pc Front to Rear
- ZCS670867 8 Cyl, 2 Pc Front to Rear, Convertible
- ZCS670967 8 Cyl, 2 Pc Front to Rear, Hardtop
- ZCS680168 6 Cyl, Convertible
- ZCS680268 6 Cyl, Hardtop
- ZCS680368 8 Cyl, Convertible
- ZCS680468 8 Cyl, Hardtop
- ZCS690169 6 Cyl, Convertible
- ZCS690269 6 Cyl, Hardtop
- ZCS690369 8 Cyl, Convertible
- ZCS690469 8 Cyl, Hardtop
- ZCS700170 6 Cyl, Convertible
- ZCS700270 6 Cyl, Hardtop
- ZCS700370 8 Cyl, Convertible
- ZCS700470 8 Cyl, Hardtop
- ZCS700570 8 Cyl, Convertible, with Vapor Line
- ZCS700670 8 Cyl, Hardtop, with Vapor Line
- ZCS7101 ...71-73... 6 Cyl
- ZCS7102 ...71-73... 8 Cyl, Drum
- ZCS7103 ...71-73... 8 Cyl, Disc

FRONT BRAKE FLEX HOSES

Front flex hoses provide a flexible connection from the body or frame to the front calipers or wheel cylinders as they move during suspension travel. Available in O.E. rubber. All of our hoses are D.O.T. approved. Hoses are priced individually.

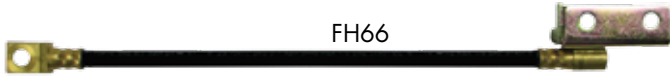

- FH60..... 64-66 Front Drum
- FH63..... 65-66 Front Disc
- FH64..... 67..... Front Disc
- FH61..... 67-70 Front Drum
- FH65..... 68-70 Disc, Left
- FH66..... 68-70 Disc, Right
- FH62..... 71-73 Front Drum
- FH95..... 71-73 Front Disc, Left
- FH96..... 71-73 Front Disc, Right

REAR BRAKE FLEX HOSES

Rear flex hoses carry brake fluid between the body of the car and the rear. Hoses are available in O.E. rubber 'T' blocks are attached whenever factory correct. All of our hoses are D.O.T. approved. Prices are per hose.

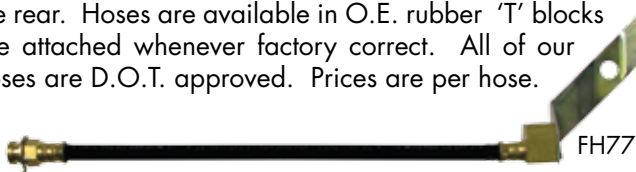

- FH67..... 64-66 All 8" Single Exhaust
- FH77..... 65-66 with Factory Dual Exhaust
- FH68..... 67-69 All Except 31 Spline
- FH52..... 68-69 31 Spline Rear Only
- FH53..... 70..... All Cars
- FH54..... 71-73 All Cars

POWER VACUUM LINES

Power brake vacuum lines connect the intake manifold fitting to the rubber hose that runs to the power brake booster. Brackets are included as noted.



ADD "S" TO PART NUMBER FOR STAINLESS STEEL

- ZBV640164-65.... 8 Cylinder, 260 & 289
- ZBV6702..... 67 428, Shelby Dual Four
- ZBV6802....67-69.... 390, 428 / Pi & CJ, Mustang Only
- ZBV6801....68-69.... 428 CJ, Torino & Cyclone Only
- ZBV6803....68-69.... 302, 351 W., & Boss 302



WHEEL CYLINDERS

Wheel cylinders are priced individually. Hardware is not included.



- WC93..... 64-73..... Left Front, 1-1/18" Bore, 8 Cyl.
- WC94..... 64-73..... Right Front, 1-1/18" Bore, 8 Cyl.
- WC95..... 67-68..... Left Front, 1-3/32" Bore, 390
- WC96..... 67-68..... Right Front, 1-3/32" Bore, 390
- WC95..... 69 Left Front, 1 -3/32" Bore, 351, 390, 428
- WC96..... 69 Right Front, 1-3/32" Bore, 351, 390, 428
- WC100.... 64-66..... Right Rear, 29/32" Bore, 8 Cyl, Before 4/15/66
- WC99..... 64-66..... Left Rear, 29/32" Bore, 8 Cyl, Before 4/15/66
- WC92..... 64-70..... Left and Right Rear, 27/32" Bore, After 8/17/64
- WC64..... 66-73..... Left Rear, 7/8" Bore, 8 Cyl., After 4/15/66
- WC65..... 66-73..... Right Rear, 7/8" Bore, 8 Cyl., After 4/15/66
- WC51..... 67-68..... Left & Right Rear, 13/16" Bore, 390
- WC100..... 70..... Right Rear, 29/32" Bore, 351, 428
- WC99..... 70..... Left Rear, 29/32" Bore, 351, 428
- WC100.... 71-72..... Right Rear, 29/32" Bore, 302, 351, 428
- WC99..... 71-72..... Left Rear, 29/32" Bore, 302, 351, 428

THERMAL CHOKE LINES

Thermal choke lines carry heat from the exhaust system to the choke coil on the carburetor. Some applications route thru the intake manifold on their way to the carburetor.



ADD "S" TO PART NUMBER FOR STAINLESS STEEL

- ZCH6502.. 64-65 ..170, 6 Cylinder, Single Line
- ZCH6503 65.....302, 5-Piece.
- ZCH6501 .. 65-69 ..289-302, Enters Under Choke, 2-Piece.
- ZCH6601 .. 66-68 ..200, 6 Cylinder, Single Line
- ZCH6701 67.....428 Shelby Dual Quad.
- ZCH6702 ..67-68 ..390, 4 BBL, GT
- ZCH6802 68.....428 P.I. w/ Tall Valve Covers
- ZCH6801 .. 68-69 ..428 CJ, KR (Over Valve Cover)
- ZCH6805 68.....302ci., 4 valve motor, J-Code, 2-Piece.
- ZCH6901 69.....351 W. Enter Under Choke Housing
- ZCH6902 69.....351 W. Enters Thru Choke Cover
- ZCH6903 69.....390, 4 BBL (Called 390 GT)
- ZCH7001 ..70-73 ..351 C., 2 BBL
- ZCH7002 ..70-73 ..351 C., 4 BBL, w/ Autolite Carb.
- ZCH7801 78.....302
- ZCH8301 83.....302 GT 5-Speed

MUSTANG FUEL & TRANSMISSION LINES

MAIN FUEL LINES

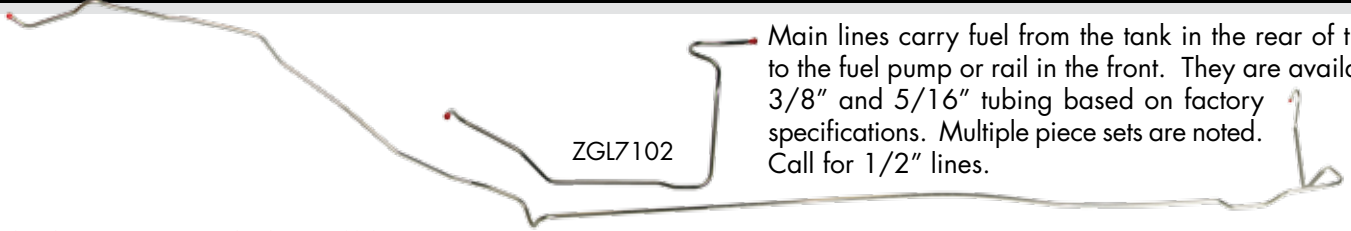

Main lines carry fuel from the tank in the rear of the car to the fuel pump or rail in the front. They are available in 3/8" and 5/16" tubing based on factory specifications. Multiple piece sets are noted. Call for 1/2" lines.

ADD "S" TO PART NUMBER FOR STAINLESS STEEL

ZGL6401 64 6 Cylinder
ZGL6402 64 5/16" Main Fuel Line
ZGL6403 64 3/8" Main Fuel Line
ZGL6501 65-66 ... 6 Cylinder
ZGL6502 65-66 ... 8 Cylinder
ZGL6503 65-66 ... "R" Model (3/8" Diameter)
ZGL6702 67 8 Cylinder, Before 2/12/67
ZGL6703 67 8 Cylinder, After 2/12/67
ZGL6706 67 6 Cylinder, Before 2/1/67
ZGL6710 67 5/16" GT-500
ZGL6701 67-70 ... 6 Cylinder, After 2/1/67

ZGL6802 68 4 Speed, Cobra Jet Only 2 Pcs.
ZGL6803 68 8 Cylinder, Ex. CJ with 4-Spd ... 2 Pcs.
ZGL6902 69 8 Cylinder 2 Pcs.
ZGL7002 70 8 Cylinder 2 Pcs.
ZGL7108 71 3/8" Boss 351 2 Pcs.
ZGL7102 71-73 ... 3/8" Main Line
ZGL7801 76-78 ... 5/16" Main Line
ZGL8201 82 5/16" Main Line
ZGL8401 84 5/16" Main Line
ZGL8501 84-86 ... 5/16" Main Line
ZGL8702 87-93 ... 5/16" Main Line, Hose Bead Ends

RETURN FUEL LINES

Return lines carry excess fuel from fuel pump or fuel filter back to the tank. Not all vehicles were equipped with a return line.

ADD "S" TO PART NUMBER FOR STAINLESS STEEL

ZGL7104 71-73 3/16" Return Line
ZGL7802 78 1/4" Return Line
ZGL8202 82 1/4" Return Line
ZGL8502 84-86 1/4" Return Line
ZGL8701 87-93 1/4" Return Line, Hose Bead Ends

HOLLEY CARB FUEL LINES

These transfer tubes join the two float bowls on factory style Holley Carburetors.

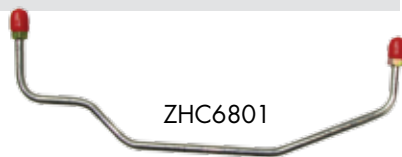

ADD "S" TO PART NUMBER FOR STAINLESS STEEL

ZHC6401 64-67 ... 715 CFM Center Pivot, w/o Grommet
ZHC6701 67-69 ... 600 CFM, Center Pivot
ZHC6801 68-71 ... 700, 730, 735, & 780 CFM

VAPOR RETURN LINES

Emission control systems use these lines to handle fuel vapors.

ADD "S" TO PART NUMBER FOR STAINLESS STEEL

ZGL7013 70 5/16" Vapor Line to Emissions
Can at Right Front of Car
ZGL7109 71 5/16" Boss 351
ZGL7103 71-73 5/16" Vapor Return Line
ZGL7803 76-78 1/4" Vapor Line, Standard
ZGL7603 76-78 6 Cylinder, Vapor Canister Line
ZGL7804 78 1/4" Vapor Line, King Cobra
ZGL7804 78 1/4" Vapor, with Extended Range
ZGL8503 84-86 1/4" Vapor Line

TRANSMISSION COOLER LINES

Transmission cooler lines are sold as pairs. Be sure to verify the type of transmission in your project before ordering. These lines are intended to work only with factory motor, transmission, and radiator combinations.

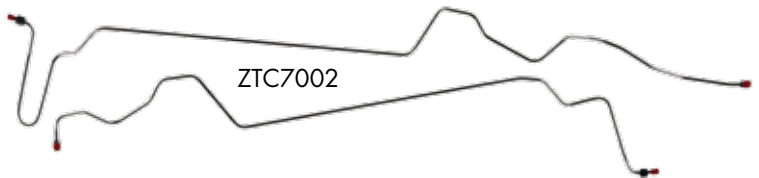

ADD "S" TO PART NUMBER FOR STAINLESS STEEL

ZTC6401 64-65 C4, 6 Cylinder, w/o Fittings at Rad.
ZTC6402 64-65 C4, 8 Cylinder, w/o Fittings at Rad.
ZTC6601 66 C4, 6 Cylinder
RSTF01 64-65 Hoses & Fittings For ZTC6401 & ZTC6402, 2 Hoses,
4 Clamps, 2 Radiator Fittings
ZTC6602 66 C4, 8 Cylinder
ZTC6703 67-68 C6, 8 Cylinder, 67-Early 68
ZTC6701 67-70 C4, 6 Cylinder
ZTC6702 67-70 C4, 8 Cylinder
RSTF02 67-73 Radiator Fittings, 2-Piece.
ZTC6803 68-70 C6, 8 Cylinder, Late 68-70
ZTC6901 69-70 FMX, 8 Cyl, 351W, Std. Cooling
ZTC6902 69-70 FMX, 8 Cyl, 351W, H.D. Cooling
ZTC6902 69-70 FMX, 8 Cyl, 351W, H.D. Cooling
ZTC7001 70 FMX, 351 C.
ZTC7002 70 C6, 428
ZTC7101 71-73 C4, 8 Cylinder
ZTC7102 71-73 FMX, 8 Cylinder
ZTC7103 71-73 C6, 8 Cylinder
ZTC7106 71-73 C4, 6 Cylinder
ZTC7801 78 All
ZTC8701 87-93 302 ci, AOD

FUEL PUMP TO CARB LINES

Fuel pump to carburetor lines connect the fuel pump to the carburetor. Brass blocks and fittings are included as noted. These lines are intended to work only with factory pump, motor, intake and carburetor combinations.

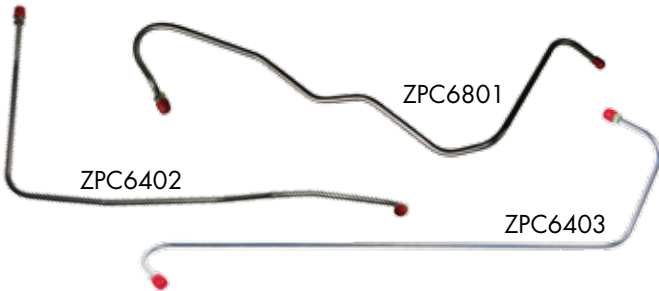

ADD "S" TO PART NUMBER FOR STAINLESS STEEL

- ZPC640164-65 6 Cylinder 170 & 200
- ZPC640264-65260 or 289, 2 or 4 BBL, Routed In Front of Distributor
- ZPC640364-65289 with 715 Holley CFM, (Shelby)
- ZPC640464-65260 or 289, 2 or 4 BBL, Routed Behind Distributor
- ZPC660166-67 6 Cylinder 200
- ZPC660366-67Shelby GT-350 with 715 CFM
- ZPC660266-68289, 2 or 4 BBL
- ZPC670167-68390 GT, 4 BBL
- ZPC6702 67428 (Shelby Dual Quad.)
- ZPC6703 67390, 2 BBL
- ZPC6704 67GT-350 Shelby with P.S.
- ZPC680168-69302, 4 BBL
- ZPC680268-70390/428, 4 BBL, (PI, CJ, SCJ)
- ZPC680368-70302 or 351 with 2 BBL
- ZPC680468-70 6 Cylinder, 250
- ZPC6901 69351 W, 4 BBL
- ZPC690269-70Boss 302
- ZPC690369-70Boss 429
- ZPC700170-73351 C., 4 BBL
- ZPC700270-73429 CJ with Spread Bore
- ZPC700370-73429 SCJ with Holley
- ZPC700470-73351 C., 2 BBL
- ZPC710271-73302, 2 BBL
- ZPC7801 78302
- ZPC8501 85302, HO

TRANSMISSION VACUUM LINES

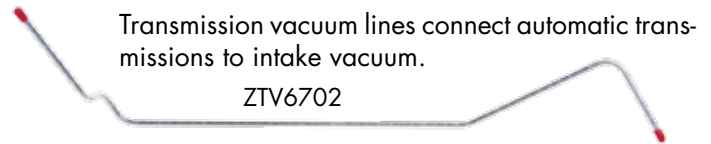

ADD "S" TO PART NUMBER FOR STAINLESS STEEL

- ZTV6401 64-65C4, 8 Cylinder with Fitting
- ZTV6402 64-68 170-200, 6 Cyl. with Fitting
- ZTV660166C4, 8 Cylinder with Hose Tip
- ZTV670367390
- ZTV6702 67-69C4, Small Block with Hose Tip
- ZTV6802 68-69C6, Big Block with Hose Tip
- ZTV700270C6, Big Block
- ZTV730173C6, 315
- ZTV780178All

DISTRIBUTOR VACUUM

Distributor vacuum lines supply intake vacuum to the distributor for timing control.

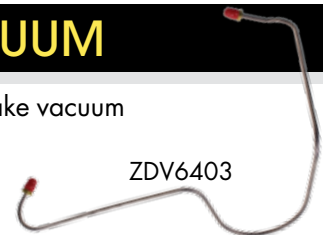

ADD "S" TO PART NUMBER FOR STAINLESS STEEL

- ZDV640164-65 6 Cylinder, 170
- ZDV640264-67289 with 4 BBL (Except Hipo)
- ZDV640364-67289 with 2 BBL
- ZDV660166-68 6 Cylinder, 200



FRONT TO REAR BRAKE LINES

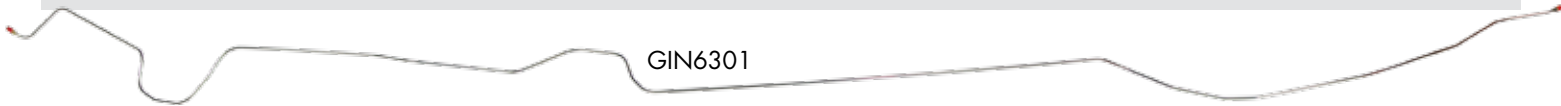

Front to rear brake lines go from the distribution, combination or metering valve along the length of the vehicle to the rear flex hose. Manufactured in 1 or 2 pieces based on factory specs.

ADD "S" TO PART NUMBER FOR STAINLESS STEEL

- GIN5301 53 Hardtop
- GIN5902 59 Hardtop
- GIN6101 ... 61-62 ... All Cars

- GIN6301 ... 63-64 ... All Cars
- GIN6501 65 Manual Drum
- GIN6601 66 Power Drum
- GIN6701 67 Manual Drum, Hardtop
- GIN6702 67 Manual Drum, Convertible
- GIN6801 68 Manual Drum
- GIN6802 68 Power Disc, Wagon

FRONT BRAKE LINE KITS

Front brake line kits consist of all brake lines under the hood. This includes the master cylinder to the distribution, combination or metering valve. The left & right front lines that run to the front flex hoses are also included. Call for individual component pricing. Kits are for vehicles with factory brake systems.

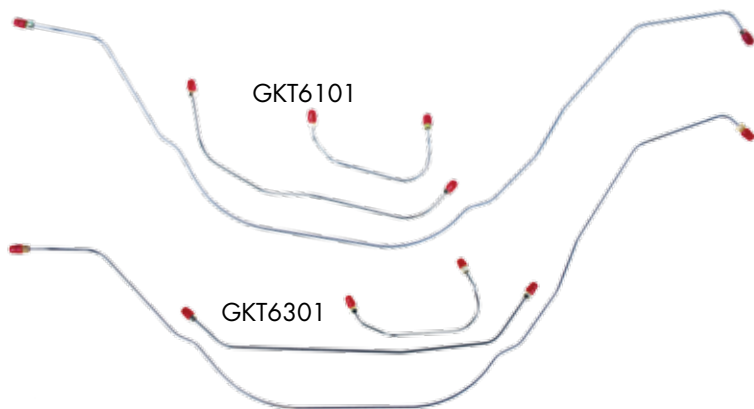

TECH TIP : 1961-1964 FRONT BRAKE KITS - On 1961-1964 Galaxies, there are two possible right front lines. Standard model cars run under the motor. Hi-performance model cars run along the radiator core support.

ADD "S" TO PART NUMBER FOR STAINLESS STEEL

- GKT5901 59 Standard Drum..... 3 Pcs.
- GKT6101 ... 61-62 ... Standard Model 3 Pcs.
- GKT6102 ... 61-62 ... Hi-Performance Model 3 Pcs.
- GKT6301 ... 63-64 ... Standard Model 3 Pcs.
- GKT6302 ... 63-64 ... Hi-Performance Model 3 Pcs.
- GKT6501 65 Standard Drum..... 3 Pcs.
- GKT6601 66 Power Drum..... 3 Pcs.
- GKT6701 67 Power Disc 7 Pcs.
- GKT6702 67 Standard Drum..... 4 Pcs.
- GKT6801 68 Power Disc 6 Pcs.
- GKT6901 69 Power Drum, Lincoln 12 Pcs.
- GKT6902 69 Power Disc 6 Pcs.
- GKT6903 69 Power Disc, 429 ci 6 Pcs.
- GKT6903 69 Manual Drum 4 Pcs.
- GKT6907 69 V-8 390 ci, Manual Drum 4 Pcs.
- GKT6906 69 Power Disc 6 Pcs.

REAR AXLE BRAKE LINES

Rear axle brake lines include a pair of lines that run across the rear axle housing. These lines connect the wheel cylinders or calipers to the flex hose in the middle of the rear end. These lines work with original housings that use factory brakes. Modifications such as rear disc brakes or narrowed rear ends will likely require special lines. Call for more information.

ADD "S" TO PART NUMBER FOR STAINLESS STEEL

- GRA6101 .. 61-62 ... All Cars
- GRA6301 .. 63-64 ... All Cars
- GRA6501 65 All Cars
- GRA6601 66 Galaxie
- GRA6701 67 All Cars, Excl. Monterey
- GRA6702 67 Monterey Only
- GRA6703 67 9" with 7/16" Fitting @ Hose
- GRA6801 68 Wagon
- GRA7001 70 All Cars

FRONT BRAKE FLEX HOSES

Front flex hoses provide a flexible connection from the body or frame to the front calipers or wheel cylinders as they move during suspension travel. Choose between O.E. rubber or braided stainless steel. Hoses are D.O.T. approved & priced individually.

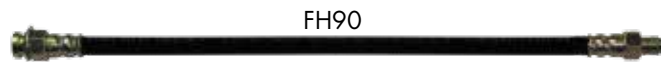

ADD "S" TO PART NUMBER FOR STAINLESS STEEL

- FH69 60-66 Front Drum - OE Steel
- FH179 67-68 Front Drum - OE Steel
- FH90 69-70 Front Drum, 240 & 302 - OE Steel

REAR BRAKE FLEX HOSES

Rear flex hoses carry brake fluid between the body of the car and the rear. Hoses are available in O.E. rubber. 'T' blocks are attached whenever factory correct. All of our hoses are D.O.T. approved. Prices are per hose.

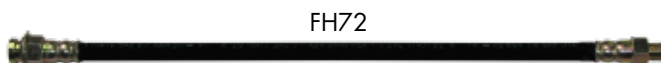

- FH72 60-64 All Cars, Rear - OE Steel

MAIN FUEL LINES

Main lines carry fuel from the tank in the rear of the car to the fuel pump or rail in the front. They are available in 3/8" and 5/16" tubing based on factory specifications. Multiple piece sets are noted. Call for 1/2" lines.

CGL6301

ADD "S" TO PART NUMBER FOR STAINLESS STEEL

GGL5901 59 5/16" Hardtop
 GGL5902 59 5/16" 6 Cylinder
 GGL6101 61-62 5/16" Standard
 GGL6102 61-62 3/8" Fuel Line for 427
 GGL6301 63-64 5/16" Standard

GGL6302 63-64 3/8" Fuel Line for 427
 GGL6701 67 5/16" Galaxie
 GGL6701 67 5/16" Monterey Convertible
 GGL6702 67 3/8" Monterey Hardtop, 2-Piece.
 GGL6801 68 5/16" Fuel Line
 GGL6903 69 3/8" Convertible

FUEL PUMP TO CARB LINES

Fuel pump to carburetor lines connect the fuel pump to the carburetor. Brass blocks and fittings are included as noted. These lines are intended to work only with factory pump, motor, intake and carburetor combinations.

ADD "S" TO PART NUMBER FOR STAINLESS STEEL

GPC5901 59 292
 GPC6101 61-64 427 or 390 with 2x4 BBL Carbs, or 3x2 BBL Carbs., 2 Line Set
 GPC6102 61-64 427, Single 4 BBL, 2 Line Set
 GPC6401 64 390, 4 BBL, 1 Pc. Line
 ZPC6402 64-65 260 or 289, 2 or 4 BBL, Routed In Front of Distributor
 ZPC6404 64-65 260 or 289, 2 or 4 BBL, Routed Behind Distributor
 GPC6501 65 352 or 390, 4 BBL
 ZPC6602 66-68 289, 2 or 4 BBL
 GPC6701 67 390, 4 BBL, Holley
 GPC6702 67 390 ci, 4 BBL, Autolite
 GPC6801 68 390 ci, 4BBL
 GPC6901 69 429 ci
 GPC6902 69 429 4 BBL

TRANSMISSION COOLER LINES

Transmission cooler lines are sold as pairs. Be sure to verify the type of transmission in your project before ordering. These lines are intended to work only with factory motor, transmission, and radiator combinations. Transmission vacuum lines connect automatic transmissions to intake vacuum.

ADD "S" TO PART NUMBER FOR STAINLESS STEEL

GTC6101 61-64 Small Block Set
 GTC6102 61-64 Big Block Set
 GTC6601 66 FMX, 289
 GTC6701 67 C6, 390
 GTC6702 67 C6, 390, Monterey
 GTC6801 68 Big Block Set
 GTC6901 69 429ci., C6
 GTC6901 69 429ci, 4 BBL
 GTV6101 61 Small Block
 GTV6301 63 Small Block
 GTV6501 65 390 ci, 4 BBL (upper)
 GTV6502 65 390 ci, 4 BBL (lower)
 GTV6701 67 Big Block
 GTV6702 67 Big Block, Monterey
 GTV6801 68 Big Block
 GTV6901 69 C6
 GTV6901 69 429 4 BBL Modulator Line

WHEEL CYLINDERS

Wheel cylinders are priced each. Hardware is not included.



WC60 60-72 Left Front 1-3/32"
 WC61 60-72 Right Front, 1-3/32"
 WC62 60-72 Left Rear, 15/16"
 WC63 60-72 Right Rear, 15/16"
 WC64 62-66 Left Rear, 7/8", Metallic Lining
 WC65 62-66 Right Rear, 7/8", Metallic Lining
 WC66 65-68 Left Rear, 3-1/32"
 WC67 65-68 Right Rear, 3-1/32"

CALIPER CROSSOVER

GFC6601 66 Caliper Crossover - OE Steel 2 Pcs.
 GFC6601S 66 Caliper Crossover - Stainless 2 Pcs.



MAVERICK & COMET LINES

FRONT BRAKE LINE KITS

Front brake line kits consist of all brake lines under the hood. This includes the master cylinder to the distribution, combination or metering valve. The left & right front lines that run to the front flex hoses are also included. Call for individual component pricing. Line kits are for vehicles with factory brake systems.

ADD "S" TO PART NUMBER FOR STAINLESS STEEL

LKT610161 Standard Drum
LKT650265 Standard Drum
LKT700170 Standard Drum
LKT7101 ... 71-74 ... Standard Drum
LKT7601 ... 76-77 ... Power Disc
LKT7602 ... 76-77 ... Standard Disc

FRONT TO REAR BRAKE LINES

Front to rear brake lines go from the distribution, combination or metering valve along the length of the vehicle to the rear flex hose. Lines are made in 1 or 2 pieces based on factory specifications.

ADD "S" TO PART NUMBER FOR STAINLESS STEEL

LIN6101 61All Cars
LIN6502 65All Cars
LIN7001 70All Cars
LIN710171-74Drum
LIN7501 75All Cars
LIN760176-77All Cars

THERMAL CHOKE LINES

Thermal choke lines carry heat from the exhaust system to the choke coil on the carburetor. Some applications route thru the intake manifold on their way to the carburetor.

ADD "S" TO PART NUMBER FOR STAINLESS STEEL

Call Us!65 Choke Line
LCH700170 6 Cylinder, 250 C.I.
LCH710171 200 C.I.
LCH720172 302 with C4, 2-Piece

FUEL LINES



ADD "S" TO PART NUMBER FOR STAINLESS STEEL

LDV620162 Fuel Tank Vent Line
LGL650165 5/16" Main Line, Maverick
LGL650365 5/16" Main Line, Comet
LPC650165 289, 4 BBL, Pump to Carburetor
LPC650265 289, 2 BBL, Pump to Carburetor
LGL700170 3/8" Main Line, 2-Piece.
LPC700170 250, 6 Cylinder, Pump to Carb
LGL7101 .. 71-74 ... 3/8" Main Line, 2-Piece.
LGL750175 5/16" Main Line

TRANSMISSION LINES

ADD "S" TO PART NUMBER FOR STAINLESS STEEL

LDV6501 ...65Distributor Vacuum
LTC650165C4, Transmission Cooler
LTV650165Transmission Vacuum
LTC720172302 with C4, Transmission Cooler
LTV720172302 with C4, Trans. Vac.
LTC750175Transmission Cooler

REAR AXLE BRAKE LINES

Rear axle brake lines include a pair of lines that run across the rear axle housing. These lines connect the wheel cylinders or calipers to the flex hose in the middle of the rear end. These lines work with original housings that use factory brakes. Modifications such as rear disc brakes or narrowed rear ends will likely require special lines. Call for more information.



ADD "S" TO PART NUMBER FOR STAINLESS STEEL

LRA6101 61All Cars
LRA6501 65All Cars
LRA7001 70All Cars
LRA710171-74All Cars



FRONT TO REAR BRAKE LINES

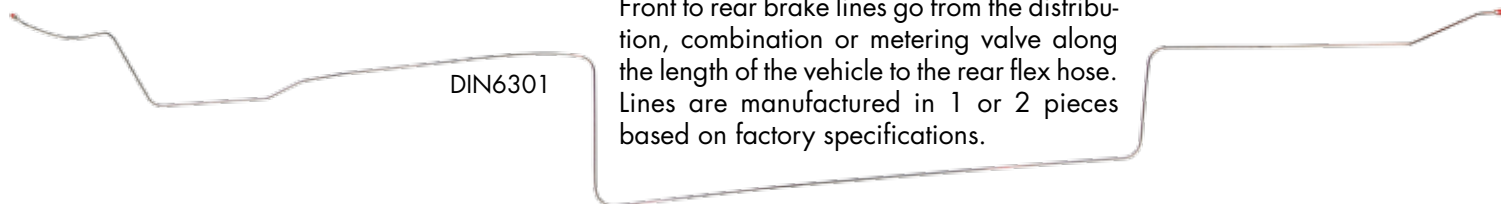

Front to rear brake lines go from the distribution, combination or metering valve along the length of the vehicle to the rear flex hose. Lines are manufactured in 1 or 2 pieces based on factory specifications.

ADD "S" TO PART NUMBER FOR STAINLESS STEEL

DIN5902 59 Fairlane
 DIN6301 62-65 All Cars
 DIN6601 66 Front Drum, Convertible
 DIN6602 66 Front Drum, Hardtop
 DIN6701 67 with Front Drum
 DIN6702 67 with Front Disc
 DIN6703 67 Fairlane Standard Drum

DIN6803 68 with Front Drum
 DIN6802 68-69 with Front Disc
 DIN7001 70-71 Ranchero
 DIN7002 70-71 All Cars, Except Cyclone
 DIN7008 70-71 Torino 500
 DIN7102 71 Cyclone Only
 DIN7401 74 with Front Disc
 DIN7402 74 Montego

FRONT BRAKE LINE KITS

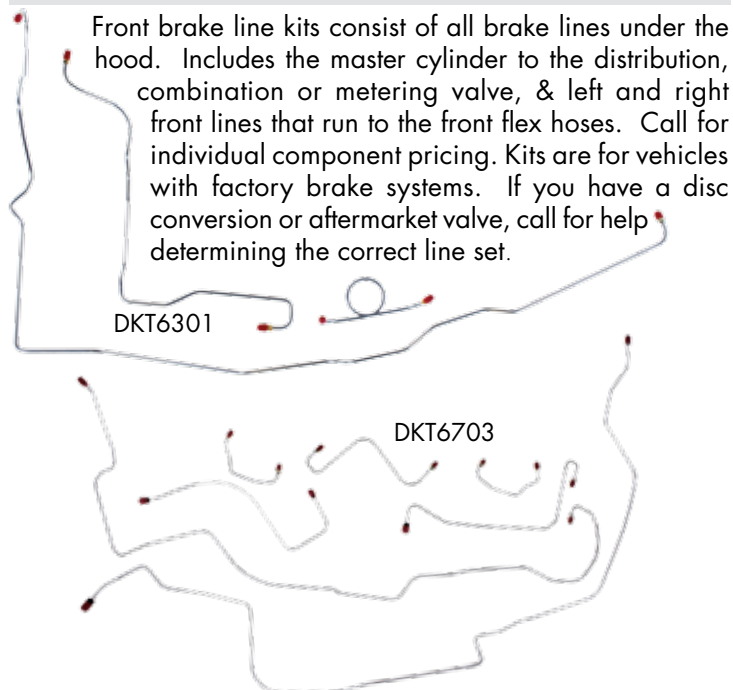

Front brake line kits consist of all brake lines under the hood. Includes the master cylinder to the distribution, combination or metering valve, & left and right front lines that run to the front flex hoses. Call for individual component pricing. Kits are for vehicles with factory brake systems. If you have a disc conversion or aftermarket valve, call for help determining the correct line set.

ADD "S" TO PART NUMBER FOR STAINLESS STEEL

DKT6301 62-65 Standard Drum Brakes
 DKT6601 66 Standard Drum Brakes
 DKT6602 66 Power Drum Brakes
 DKT6603 66 GTA, Manual Disc
 DKT6605 66 GTA, Power Drum
 DKT6701 67 Power Drum
 DKT6702 67 Standard Drum
 DKT6703 67 Power Disc Brakes
 DKT6801 68-69 Standard Drum
 DKT6802 68-69 Power Disc
 DKT7001 70-71 Power Disc, Ex. Cyclone
 DKT7002 70-71 Power Drum
 DKT7003 70-71 Torino 500, Manual Drum
 DKT7102 71 Power Disc, Cyclone
 DKT7401 72-74 Power Disc, Cyclone
 DKT7402 74 Montego

REAR AXLE BRAKE LINES

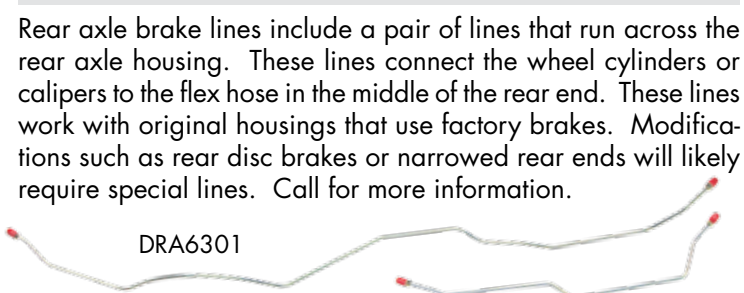

Rear axle brake lines include a pair of lines that run across the rear axle housing. These lines connect the wheel cylinders or calipers to the flex hose in the middle of the rear end. These lines work with original housings that use factory brakes. Modifications such as rear disc brakes or narrowed rear ends will likely require special lines. Call for more information.

ADD "S" TO PART NUMBER FOR STAINLESS STEEL

DRA6201 62 All, Pair
 DRA6301 63-65 8" Rear, Pair
 DRA6501 65 9" Rear
 DRA6601 66-67 8" & 9" Rear, Pair
 DRA6702 67 9" 28 Spline, Pair
 DRA6703 67 9", 31 Spline, Pair
 DRA6803 68-69 9" Rear, Ex. Cyclone, Pair
 DRA6901 69 8" Rear
 DRA7004 70-71 9" Rear, Ex. Cyclone, Pair
 DRA7008 70-71 Torino 500
 DRA7101 71 9", 31 Spline, Cyclone Only, Pair
 DRA7401 74 9" Rear, Pair
 DRA7402 74 Montego

DISC CALIPER LINES

Front disc caliper lines connect the front flex hoses to the calipers. They were typically used on 4 piston calipers in the late 1960's. Please verify fitting sizes before ordering as rebuilt calipers may not match the originals.



ZFC6401 65-67 ... Caliper X-Over Lines, Kelsey-Hayes
 4 Piston - OE Steel
 ZFC6401S .. 65-67 ... Caliper X-Over Lines, Kelsey-Hayes
 4 Piston - Stainless

FAIRLANE, TORINO & CYCLONE LINES

FRONT BRAKE FLEX HOSES

Front flex hoses provide a flexible connection from the body or frame to the front calipers or wheel cylinders as they move during suspension travel. Hoses are available in O.E. rubber. All of our hoses are D.O.T. approved. Hoses are priced individually.

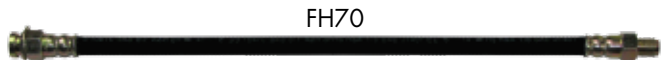

- FH69.....62-65..... Drum
- FH75..... 66..... Drum
- FH61.....67-70..... Drum
- FH70.....68-70..... Disc - Left
- FH71.....68-70..... Disc - Right

REAR BRAKE FLEX HOSES

Rear flex hoses carry brake fluid between the body of the car and the rear. Hoses are available in O.E. rubber. 'T' blocks are attached whenever factory correct. All of our hoses are D.O.T. approved. Prices are per hose.



- FH72.....62-65..... All Except 289, 4 BBL
- FH73..... 66..... All Cars

FUEL PUMP TO CARB LINES

Fuel pump to carburetor lines connect the fuel pump to the carburetor. Brass blocks and fittings are included as noted. These lines are intended to work only with factory pump, motor, intake and carburetor combinations.

ADD "S" TO PART NUMBER FOR STAINLESS STEEL

- ZPC6401.... 64-65 6 Cylinder 170 & 200
- ZPC6402.... 64-65 260 or 289 or 4 BBL, Routed in Front of Distributor
- ZPC6404.... 64-65 260 or 289, 2 or 4 BBL, Routed Behind Distributor
- DPC6603 66 390, with 4 BBL
- ZPC6601 66-67 6 Cylinder 200
- ZPC6602.... 66-68 289 or 4 BBL
- ZPC6701 67 390 4 BBL
- ZPC6703..... 67 390 2 BBL
- ZPC6801 68-69 302 4 BBL
- ZPC6802.... 68-70 390/428 4 BBL, (PI, CJ, SCJ)
- ZPC6803.... 68-70 302 or 351 with 2 BBL
- ZPC6804.... 68-70 6 Cylinder, 250
- ZPC6901 69 351 W, 4 BBL
- ZPC7001 70-73 351 C., 4 BBL
- ZPC7002.... 70-73 429 CJ with Spread Bore
- ZPC7003.... 70-73 429 SCJ with Holley
- ZPC7004.... 70-73 351 C. 2 BBL
- ZPC7102.... 71-73 Motorcraft Carb

WHEEL CYLINDERS

Wheel cylinders are priced each. Hardware is not included.

- WC93..... 66-69Left Front, S.W. 1-1/8"
- WC94..... 66-69Right Front, S.W. 1-1/8"
- WC95..... 66-69Left Front, Exc. S.W. 1-3/32"
- WC96..... 66-69Right Front, Exc. S.W. 1-1/32"
- WC93..... 70-71Left Front, 8 Cyl, 1-1/8"
- WC94..... 70-71Right Front, S.W. 1-1/8"
- WC95..... 70-71Left Front, All 1-3/32"
- WC96..... 70-71Right Front, All 1-3/32"

RETURN FUEL LINES

Return lines carry excess fuel from fuel pump or fuel filter back to the tank. Not all vehicles were equipped with a return line. Multiple piece sets are noted.

ADD "S" TO PART NUMBER FOR STAINLESS STEEL

- DGL7106 ..70-71 .. 3/16" Ranchero 2 Pcs.
- DGL7102 71..... 3/16" Cyclone with 429 2 Pcs.
- DGL7402 74..... 1/4" Montego

THERMAL CHOKE LINES

Thermal choke lines carry heat from the exhaust system to the choke coil on the carburetor. Some applications route thru the intake manifold on their way to the carburetor.

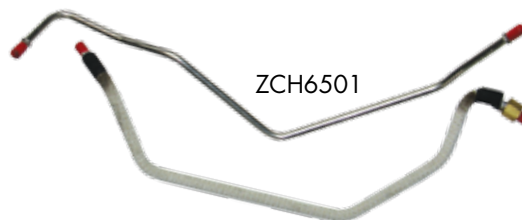

ADD "S" TO PART NUMBER FOR STAINLESS STEEL

- ZCH6502... 64-65 ... 170, 6 Cylinder, Single Line
- ZCH6501 ... 65-69 ... 289-302, Enters Under Choke Housing
- DCH6603.....66 390 with 4 BBL, 2-Piece.
- ZCH6601 ... 66-68 ... 200, 6 Cylinder, Single Line
- ZCH6702... 67-68 ... 390 4 BBL GT
- ZCH6801 ... 68-69 ... 428 CJ, KR (Over Valve Cover)
- ZCH6901 69 351 W, Enters under Choke Housing
- ZCH6902..... 69 351 W, Enters Thru Choke Cover
- ZCH7001 ... 70-73 ... 351 C., 2 BBL

MAIN FUEL LINES

Main lines carry fuel from the tank in the rear of the car to the fuel pump or rail in the front. They are available in 3/8" and 5/16" tubing based on factory specifications. Multiple piece sets are noted. Call for 1/2" lines.

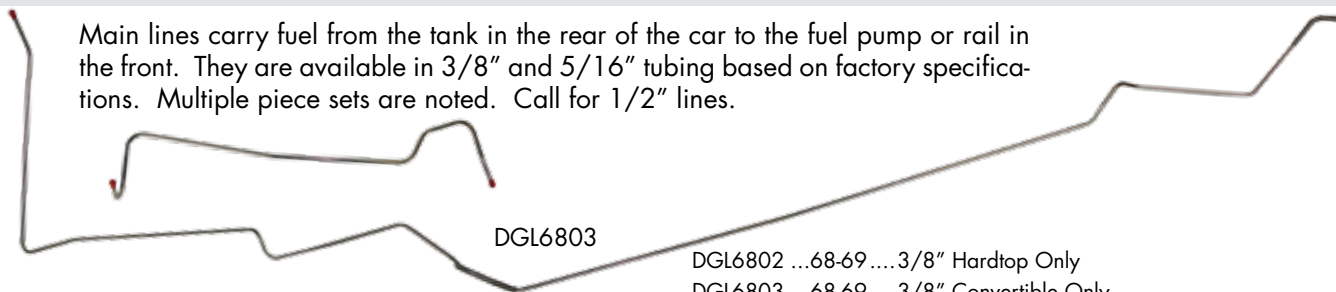

ADD "S" TO PART NUMBER FOR STAINLESS STEEL

DGL6301 ...63-65....5/16" Line

DGL6302 ...63-65....3/8" Line

DGL660466.....5/16" Main Fuel Line

DGL660566.....3/8" Line, 427 CI, HT

DGL6601 ...66-67....5/16" Line, Hardtop

DGL6602 ...66-67....3/8" Line, Hardtop

DGL6603 ...66-67....5/16", Convertible

DFV660166-67....Fuel Tank Vent Line

DGL670167.....Fairlane 500 HT

DGL670267.....3/8" Fairlane

DGL670367.....5/16" Late Fairlane Conv't.

DGL6801 ...68-69....3/8" Ranchero Only

DGL6802 ...68-69....3/8" Hardtop Only

DGL6803 ...68-69....3/8" Convertible Only

DGL6804 ...68-69....Cyclone, Hardtop

DGL680568.....Torino, Hardtop Main Fuel Line

DGL700170.....3/8" Automatic,
without Staggered Shocks

DGL700370.....3/8" 4-Speed,
with Staggered Shocks

DGL700570.....3/8" 4-Speed,
without Staggered Shocks

DGL700670.....Torino Convertible

DGL7104 ...70-71....3/8" Main, Ranchero

DGL7008 ...70-71....3/8" Torino 500

DGL7101 ...70-71....3/8" Cyclone/Montego

DGL740174.....3/8" Montego

VACUUM LINES

ADD "S" TO PART NUMBER FOR STAINLESS STEEL

GVW5901 ..59Wiper Vacuum Set, 2-Piece.

DDV640264Distributor Vacuum, 6 Cyl with 2 BBL

DBV660166Brake Vacuum Line

DBV660266Transmission Vacuum, 8 Cyl with C6

DDV660366Distributor Vacuum, 390 with 4 BBL

DTV660166Transmission Vacuum, 8 Cyl, with C4

VAPOR RETURN LINES

Emission control systems use these 5/16" lines to handle fuel vapors. Some vehicles use a single front to rear line. Others utilize a charcoal canister and require 3 or 4 additional small lines. Multiple piece sets are noted.

ADD "S" TO PART NUMBER FOR STAINLESS STEEL

DGL710570-71.....5/16" Ranchero

DGL700970-71.....5/16" Torino 500

DGL710371.....5/16" Cyclone with 429

DGL720372.....5/16" Vapor

HOLLEY CARB FUEL LINES

These transfer tubes join the two float bowls on factory style Holley Carburetors.

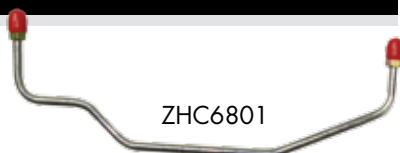

ADD "S" TO PART NUMBER FOR STAINLESS STEEL

ZHC640164-67.....715 CFM Center Pivot

ZHC670167-69.....600 CFM, Center Pivot

ZHC680168-71.....700, 730, 735, & 780 CFM

TRANSMISSION COOLER LINES

Transmission cooler lines are sold as pairs. Be sure to verify the type of transmission in your project before ordering. These lines are intended to work only with factory motor, transmission, and radiator combinations. Transmission vacuum lines connect automatic transmissions to intake vacuum.

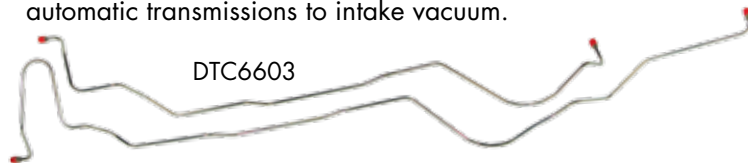

ADD "S" TO PART NUMBER FOR STAINLESS STEEL

DTC570157.....2 Speed

DTC640164.....Convertible with C4

DTC660266-69.....Small Block with C4

DTC660366-69.....Big Block with C6

DTC670367-69.....Small Block with C6

DTC680168-69.....390/428 Cobrajets with C6

DTC700170.....Big Block with C6

DTC700270.....351 with C6, 2-Piece

DTC700870-71.....Torino 500, with C4, 2-Piece

DTC710171.....Big Block with C4

DTC740174.....Small Block with FMX



FRONT BRAKE LINES

Front brake line kits consist of all brake lines under the hood. This includes the master cylinder to the distribution, combination or metering valve. The left and right front lines that run to the front flex hoses are also included. Call for individual component pricing. These line kits are for vehicles with factory brake systems.

ADD "S" TO PART NUMBER FOR STAINLESS STEEL

SKT5502	55	Power Brakes	3 Pcs.
SKT5501 ..	55-57 ...	Standard Brakes.....	3 Pcs.
SKT5602	56	Power Brakes	3 Pcs.
SKT5702	57	Power Brakes	4 Pcs.
SKT5801	58	Standard Brakes.....	3 Pcs.
SKT5901 ..	59-60 ...	Power Brakes, without Firewall Mounted Booster.....	3 Pcs.
SKT5902 ..	59-60 ...	Standard Brakes, with Firewall Mounted Booster.....	3 Pcs.
SKT6101 ..	61-63 ...	Power Brakes, with Firewall Mounted Booster.....	3 Pcs.
SKT6301 ..	63-64 ...	Power Brakes	3 Pcs.
SKT6501 ..	65-66 ...	Power Brakes	3 Pcs.
SKT7901 ..	77-79 ...	Power Disc	4 Pcs.

FRONT TO REAR BRAKE LINES

Front to rear brake lines go from the distribution, combination or metering valve along the length of the vehicle to the rear flex hose. Lines are manufactured in 1 or 2 pieces based on factory specifications.

SIN5501

ADD "S" TO PART NUMBER FOR STAINLESS STEEL

SIN5502	55	Rear Section
SIN5501	55-57	Front Section
SIN5602	56	Rear Section
SIN5702	57	Rear Section
SIN5801	58-60.....	All Cars
SIN6101	61-62.....	All Cars
SIN6201	63	All Cars
SIN6401	64-66.....	All Cars
SIN7901	77-79.....	All Cars

FRONT BRAKE FLEX HOSES

Front flex hoses provide a flexible connection from the body or frame to the front calipers or wheel cylinders as they move during suspension travel. Hoses are available in O.E. rubber. All of our hoses are D.O.T. approved. Hoses are priced individually.

FH113.....	55-57	Front
FH72.....	58	Front
FH69.....	59-60.....	Front
FH72.....	62-64.....	Front

236

REAR AXLE BRAKE LINES

Rear axle brake lines include a pair of lines that run across the rear axle housing. These lines connect the wheel cylinders or calipers to the flex hose in the middle of the rear end. These lines work with original housings that use factory brakes. Modifications such as rear disc brakes or narrowed rear ends will likely require special lines. Call for more information.

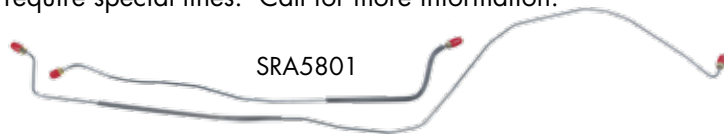

ADD "S" TO PART NUMBER FOR STAINLESS STEEL

SRA5501	55-56	All Cars	2 Pcs.
SRA5701	57	All Cars	2 Pcs.
SRA5801	58-60	All Cars	2 Pcs.
SRA6101	61-62	All Cars	2 Pcs.
SRA6201	63	All Cars	2 Pcs.
SRA6401	64-66	All Cars	2 Pcs.
SRA7101	71	All Cars	2 Pcs.
SRA7801	77-79	31 Spline Only.....	2 Pcs.
SRA7901	77-79	All Cars, Excl. 31 Spline.....	2 Pcs.

FUEL PUMP TO CARB LINES

Fuel pump to carburetor lines connect the fuel pump to the carburetor. Brass blocks and fittings are included as noted. These lines are intended to work only with factory pump, motor, intake and carburetor combinations.

ADD "S" TO PART NUMBER FOR STAINLESS STEEL

SPC5701	57	Pump to Carb. Set.....	2 Pcs.
SPC5702	57	Pump to Carb. Set.....	4 Pcs.
SPC5901	59	430	2 Pcs.
SPC5801	60	352	
SPC6201	62-65	332/390	
SPC6304	63	390 with Autolite 4100	
SPC6601	66	390	

WHEEL CYLINDERS

Wheel cylinders are priced individually. Hardware not included.

WC102.....	55-57	Left Front
WC103.....	55-57	Right Front
WC104.....	55-57	Left Rear
WC105.....	55-57	Right Rear

REAR BRAKE FLEX HOSES

Rear flex hoses carry brake fluid between the body of the car and the rear. Hoses are available in O.E. rubber. 'T' blocks are attached whenever factory correct. All of our hoses are D.O.T. approved. Prices are per hose.

FH114.....	55-57	Rear
FH72.....	59-60	Rear

VACUUM LINES

ADD "S" TO PART NUMBER FOR STAINLESS STEEL

SDV5701 57 Distributor Vacuum, All Cars
SDV5702 57 All Cars, Dist. Vacuum Line
SFV5703 57 Fuel Pump Vacuum..... 2 Pcs.
SMV5704 57 Manifold Vacuum 2 Pcs.
SDV5901	...59-60 Distributor Vacuum with 352ci
SFV5801 60 Fuel Pump Vac. Lines..... 2 Pcs.
SDV6101	...61-62 Distributor Vacuum, 390
STV6101	...61-64 390 Cruise-a-Matic
SDV6401 64 Distributor Vacuum, 390
STV6501	...65-66 390 Cruise-a-matic
STV6502	...65-66 390 Cruise-a-Matic with Cruise
GTV6601 66 C6, Trans. Vacuum

TRANSMISSION COOLER LINES

Transmission cooler lines are sold as pairs. Be sure to verify the type of transmission in your project before ordering. These lines are intended to work only with factory motor, transmission, and radiator combinations.

ADD "S" TO PART NUMBER FOR STAINLESS STEEL

STC5602 56-57 Without Expansion Loop
STC5603 56-57 With Expansion Loop
STC5901 58-60 All Cars
STC6001 60 All Cars 4 Pcs.
STC6201 61-63 With FMX 4 Pcs.
STC6402 64 C-4 4 Pcs.
STC6401 64-66 With FMX 4 Pcs.
STC6601 66 With C-6..... 4 Pcs.

MAIN FUEL LINES

Main lines carry fuel from the tank in the rear of the car to the fuel pump or rail in the front. They are available in 3/8" and 5/16" tubing based on factory specifications. Multiple piece sets are noted. Call for 1/2" lines.

ADD "S" TO PART NUMBER FOR STAINLESS STEEL

SGL5501 55-57 5/16" Main Line 2 Pcs.
SGL6001 58-60 5/16" Main Line
SGL6001 58-60 5/16" Main Line
SGL6102 61-62 5/16" Main Line 2 Pcs.
SGL6202 62-63 3/8" Main Line 2 Pcs.
SGL6402 64 3/8" Main Line 2 Pcs.
SGL6502 65 3/8" Main Line 2 Pcs.
SGL6602 66 3/8" Main Line 2 Pcs.
SGL7901 77-79 3/8" Main Line

POWER STEERING LINES

Power steering lines can be either pressure or return feeds in a power steering system.

SPS001 61-62 Power Steering Return Line - OE Steel
SPS001S 61-62 Power Steering Return Line - Stainless

THERMAL CHOKE LINES

Thermal choke lines carry heat from the exhaust system to the choke coil on the carburetor. Some applications route thru the intake manifold on their way to the carburetor.

ADD "S" TO PART NUMBER FOR STAINLESS STEEL

SCH5801 58-59 332/352 2 Lines & Insulator
SCH5901 59-61 430 Hot Air Line & Insulator
SCH6501 65 390 with 4 BBL



FALCON BRAKE LINES

FRONT TO REAR BRAKE LINES

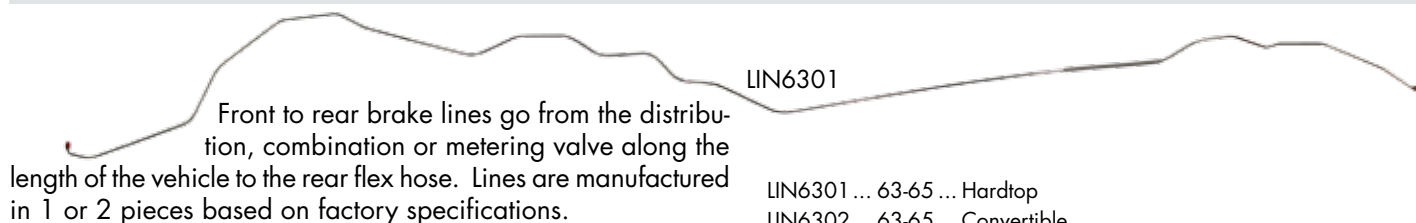

ADD "S" TO PART NUMBER FOR STAINLESS STEEL

- LIN600160 All Cars
- LIN620162 All Cars

LIN6301

- LIN6301 ... 63-65 ... Hardtop
- LIN6302 ... 63-65 ... Convertible
- LIN650465 Wagon
- LIN660166 All Cars
- LIN680168 6 Cylinder, Coupe

FRONT BRAKE LINES

Front brake line kits consist of all brake lines under the hood. This includes the master cylinder to the distribution, combination or metering valve. The left and right front lines that run to the front flex hoses are also included. Call for individual component pricing. These line kits are for vehicles with factory brake systems.

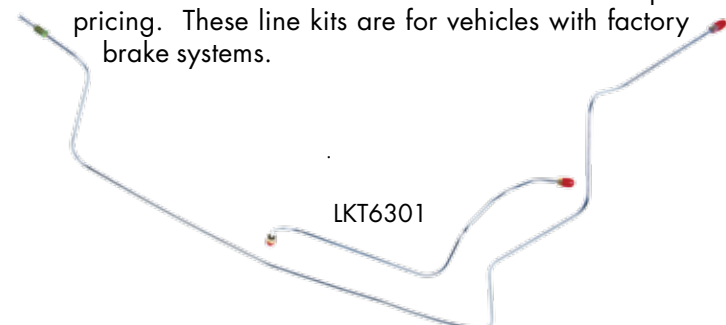

ADD "S" TO PART NUMBER FOR STAINLESS STEEL

- LKT600160 Standard Drum..... 2 Pcs.
- LKT620162 Left & Right Front, Std. Drum 2 Pcs.
- LKT6301 ... 63-65 ... Left & Right Front, Std. Drum 2 Pcs.
- LKT660166 Standard Drum..... 3 Pcs.
- LKT680168 Coupe, Standard Drum 5 Pcs.
- LKT690169 Standard Drum..... 6 Pcs.

TRANSMISSION COOLER LINES

Transmission cooler lines are sold as pairs. Be sure to verify the type of transmission in your project before ordering. These lines are intended to work only with factory motor, transmission, and radiator combinations.

- LTC620162-65.....With C-3, 2-Speed - OE Steel
- LTC6201S.....62-65.....With C-3, 2-Speed - Stainless
- LTC6402..... 64260, V-8, 2-Speed Auto - OE Steel
- LTC6402S..... 64260, V-8, 2-Speed Auto - Stainless

REAR BRAKE FLEX HOSES

Rear flex hoses carry brake fluid between the body of the car and the rear. 'T' blocks are attached whenever factory correct. All of our hoses are D.O.T. approved. Prices are per hose.

- FH78..... 60-65..... Rear
- FH69..... 66 Rear

REAR AXLE BRAKE LINES

Rear axle brake lines include a pair of lines that run across the rear axle housing. They connect the wheel cylinders or calipers to the flex hose in the middle of the rear end on original housings that use factory brakes. Modifications such as rear disc brakes or narrowed rear ends will likely require special lines.

ADD "S" TO PART NUMBER FOR STAINLESS STEEL

- LRA600160 All Cars..... 2 Pcs.
- LRA620162 6 Cylinder 2 Pcs.
- LRA630663 6 Cylinder Wagon 2 Pcs.
- LRA6301 .. 63-65 ... 6 Cylinder 2 Pcs.
- LRA6302 .. 63-65 ... 8" Rear 2 Pcs.
- LRA660166 All Cars..... 2 Pcs.
- LRA680168 6 Cylinder, Coupe..... 2 Pcs.
- LRA690169 All Cars..... 2 Pcs.

WHEEL CYLINDERS



Wheel cylinders are priced individually. Hardware is not included.

- WC97..... 60-64 Rear, S.W. 7/8"
- WC98..... 60-65 Rear, H. T. 13/16"
- WC62..... 63-66 Left Rear, 8 Cyl. S.W. 15/16"
- WC63..... 63-66 Right Rear, 8 Cyl. S.W. 15/16"
- WC100..... 63-68 Right Rear, 8 Cyl. H.T. 29/32"
- WC99..... 63-68 Left Rear, 8 Cyl. H.T. 29/32"
- WC93..... 63-70 Left Front, V-8, 1-1/8"
- WC94..... 63-70 Right Front, V-8, 1-1/8"
- WC92..... 66 Rear, All Exc. S.W. 1-1/16"
- WC95..... 66-70 Left Front, 8 Cyl. 1-3/32"
- WC96..... 66-70 Right Front, 8 Cyl. 1-3/32"

FRONT BRAKE FLEX HOSES

Front flex hoses provide a flexible connection from the body or frame to the front calipers or wheel cylinders as they move during suspension travel. Hoses are available in O.E. rubber. All are D.O.T. approved & sold each.

- FH78..... 60-64..... Front
- FH69..... 65-66..... Front

MAIN FUEL LINES

Main lines carry fuel from the tank in the rear of the car to the fuel pump or rail in the front. They are available in 3/8" and 5/16" tubing based on factory specifications. Multiple piece sets are noted. Call for 1/2" lines.

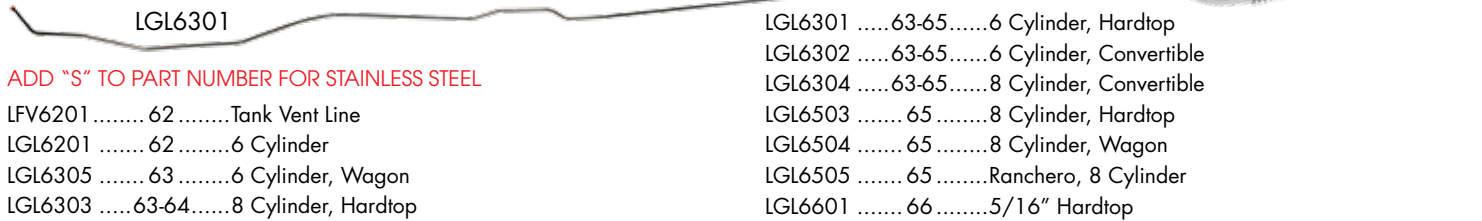

ADD "S" TO PART NUMBER FOR STAINLESS STEEL

- LFV6201 62 Tank Vent Line
- LGL6201 62 6 Cylinder
- LGL6305 63 6 Cylinder, Wagon
- LGL6303 63-64 8 Cylinder, Hardtop

- LGL6301 63-65 6 Cylinder, Hardtop
- LGL6302 63-65 6 Cylinder, Convertible
- LGL6304 63-65 8 Cylinder, Convertible
- LGL6503 65 8 Cylinder, Hardtop
- LGL6504 65 8 Cylinder, Wagon
- LGL6505 65 Ranchero, 8 Cylinder
- LGL6601 66 5/16" Hardtop

DISTRIBUTOR VACUUM LINES

Distributor vacuum lines supply intake vacuum to the distributor for timing control.

ADD "S" TO PART NUMBER FOR STAINLESS STEEL

- LDV6001 60 Dist. To Carb Line
- LDV6201 62 6 Cylinder
- LDV6301 63 6 Cylinder
- LDV6308 .. 63-65 ... 8 Cylinder

FUEL PUMP TO CARB LINES

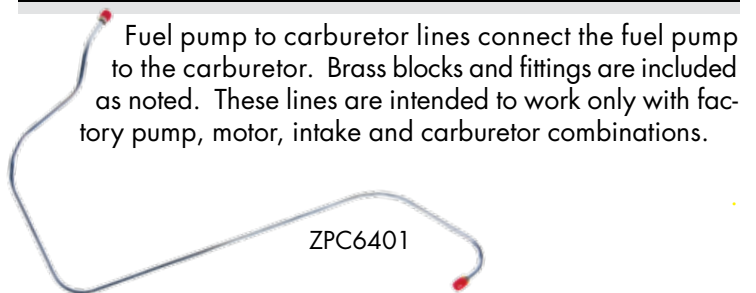

Fuel pump to carburetor lines connect the fuel pump to the carburetor. Brass blocks and fittings are included as noted. These lines are intended to work only with factory pump, motor, intake and carburetor combinations.

ADD "S" TO PART NUMBER FOR STAINLESS STEEL

- LPC6001 60 6 Cylinder
- LPC6201 62 6 Cylinder
- LPC6301 63 6 Cylinder
- ZPC6401 64-65 6 Cylinder 170 & 200
- ZPC6402 64-65 260 or 289 2 or 4 BBL, Routed In Front of Distributor
- ZPC6404 64-65 260 or 289, 2 or 4 BBL, Routed Behind Distributor
- LPC6501 65 6 Cylinder
- ZPC6601 66-67 6 Cylinder 200
- ZPC6602 66-68 289, 2 or 4 BBL

LINES NOT LISTED?



If you need a line that is not listed in our catalog and you have a good original, you may qualify for free lines. Call us today for details.



COUGAR BRAKE LINES

FRONT BRAKE LINES

Front brake line kits consist of all brake lines under the hood. This includes the master cylinder to the distribution, combination or metering valve. The left and right front lines that run to the front flex hoses are also included. Call for individual component pricing. These line kits are for vehicles with factory brake systems.

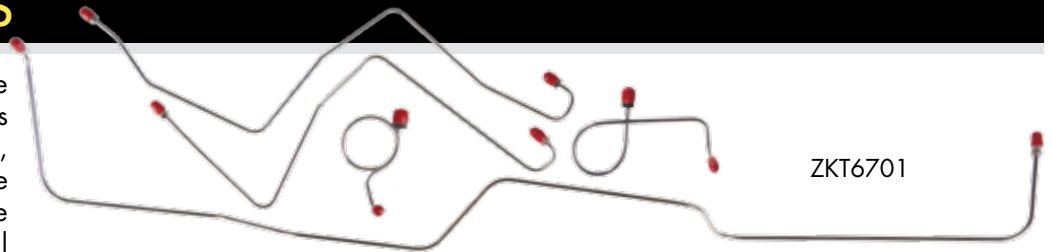

ADD "S" TO PART NUMBER FOR STAINLESS STEEL

- ZKT670167 Standard Drum, Early, Right Front
Runs Over Column5 Pcs.
- ZKT670267 Standard Drum, Late, Right Front
Runs Under Column.....5 Pcs.
- ZKT670367 Front Disc, Early, Right Front
Runs Over Column6 Pcs.
- ZKT670467 Front Disc, Late, Right Front
Runs Under Column.....6 Pcs.
- ZKT670567 Power Drum, Before 2/1/67,
Right Front Runs Over Column .5 Pcs.

- ZKT670667 Power Drum, After 2/1/67,
Right Under Column5 Pcs.
- ZKT680168 Standard Drum.....5 Pcs.
- ZKT6803 .. 68-69 ... Front Disc6 Pcs.
- ZKT690169 Front Disc, Boss 429.....6 Pcs.
- ZKT700170 Standard Drum.....5 Pcs.
- ZKT700270 Front Disc4 Pcs.
- ZKT7102 .. 71-72 ... Front Disc5 Pcs.
- ZKT7101 .. 71-73 ... Front Drum.....5 Pcs.
- ZKT730273 Front Disc5 Pcs.

FRONT TO REAR BRAKE LINES

Front to rear brake lines go from the distribution, combination or metering valve along the length of the vehicle to the rear flex hose. Lines are manufactured in 1 or 2 pieces based on factory specifications.

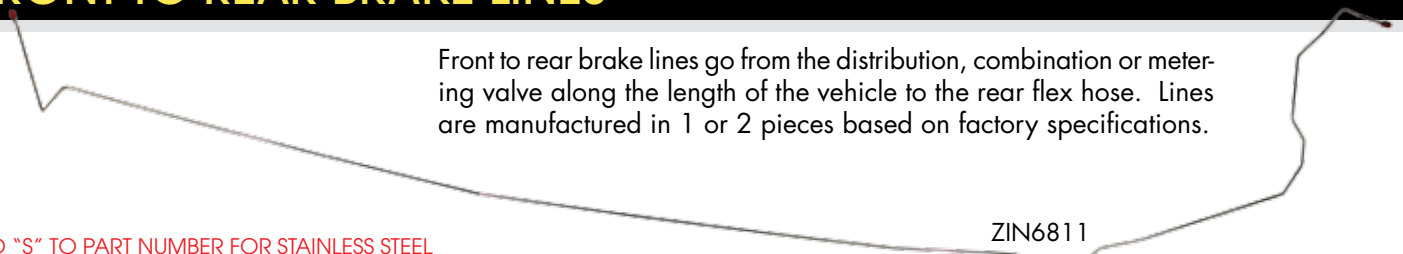

ADD "S" TO PART NUMBER FOR STAINLESS STEEL

- ZIN6711 67 Front Drum, Before 2/1/67
- ZIN6712 67 Front Disc, Before 2/1/67, 2-Piece
- ZIN6714 67 Front Disc, After 2/1/67, 2-Piece
- ZIN681168-69.... All Cars
- ZIN7011 70 Front Drum & 70 Rear Axle
- ZIN701270 Front Disc & 70 Rear Axle

- ZIN701370 Front Drum & 69 Rear Axle
- ZIN701470 Front Disc & 69 Rear Axle
- ZIN710171 Front Drum
- ZIN710271 Front Disc
- ZIN720172-73.... Front Drum
- ZIN720272-73.... Front Disc

FRONT BRAKE FLEX HOSES

Front flex hoses provide a flexible connection from the body or frame to the front calipers or wheel cylinders as they move during suspension travel. Hoses are available in O.E. rubber.. All of our hoses are D.O.T. approved. Hoses are priced individually.

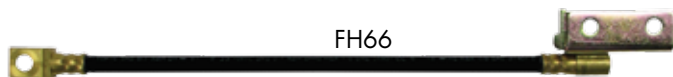

- FH64..... 67..... Front Disc
- FH61..... 67-70 Front Drum
- FH65..... 68-70 Front Disc, Left
- FH66..... 68-70 Front Disc, Right

REAR BRAKE FLEX HOSES

Rear flex hoses carry brake fluid between the body of the car and the rear. Hoses are available in O.E. rubber. 'T' blocks are attached whenever factory correct. D.O.T. approved. Prices are per hose.

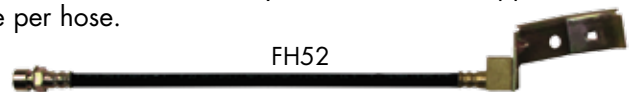

- FH68..... 67-69 Rear, All Except 31 Spline
- FH52..... 68-69 Rear, 31 Spline Rear
- FH53..... 70..... Rear, All Cars

LINES NOT LISTED?

If you need a line that is not listed in our catalog and you have a good original, you may qualify for free lines. Call us today for details.



REAR AXLE BRAKE LINES

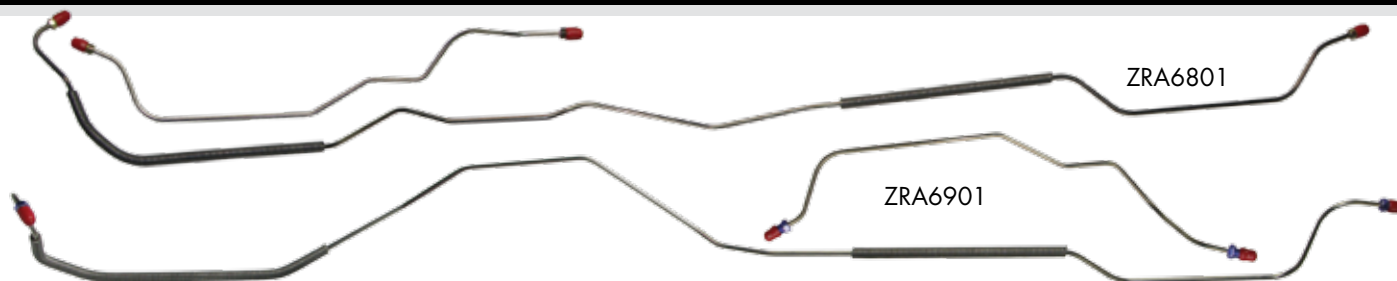

Rear axle brake lines include a pair of lines that run across the rear axle housing. These lines connect the wheel cylinders or calipers to the flex hose in the middle of the rear end. These lines work with original housings that use factory brakes. Modifications such as rear disc brakes or narrowed rear ends will likely require special lines. Call for more information.

ADD "S" TO PART NUMBER FOR STAINLESS STEEL

ZRA6703..... 67..... 9", 28 Spline Axle
 ZRA6702..... 67-69 8"
 ZRA6802..... 67-69 9", 31 Spline Axle
 ZRA6801..... 68..... 9", 28 Spline Axle

ZRA6901..... 69..... 9", 28 Spline Axle
 ZRA7002..... 70..... 8"
 ZRA7003..... 70..... 9"
 ZRA7102..... 71-73 8" or 9"

FACTORY LINE CLIP SETS

Brake line clip sets contain all the clips needed to fasten the brake tubes to the fram or body of the car.



ZCS6705 67..... 8 Cyl, 1 Pc Front to Rear 28 Pcs
 ZCS6709 67..... 8 Cyl, 2 Pc Front to Rear, Hardtop..... 34 Pcs
 ZCS6804 68..... 8 Cyl, Hardtop..... 31 Pcs
 ZCS6903 69..... 8 Cyl, Convertible 34 Pcs
 ZCS6904 69..... 8 Cyl, Hardtop..... 33 Pcs
 ZCS7003 70..... 8 Cyl, Convertible 37 Pcs
 ZCS7004 70..... 8 Cyl, Hardtop..... 37 Pcs
 ZCS7005 70..... 8 Cyl, Convertible, with Vapor Line 37 Pcs
 ZCS7006 70..... 8 Cyl, Hardtop, with Vapor Line 37 Pcs
 ZCS7102 ... 71-73 ... 8 Cyl, Drum 45 Pcs
 ZCS7103 ... 71-73 ... 8 Cyl, Disc 45 Pcs

GENERIC LINE CLIP SETS

These sets consist of generic clips that get the job done.



ZCS6401 67 Brake & 1 Pc Fuel Line
 ZCS6701 67-70... Brake & 2 Pc 5/16 Fuel Line
 ZCS6703 68 Brake & 2 Pc 3/8 Fuel Line
 ZCS7601 76 Brake Clip Set
 ZCS7603 76 5/16" Main, 1/4" Return Fuel Set

THERMAL CHOKE LINES

Thermal choke lines carry heat from the exhaust system to the choke coil on the carburetor. Some applications route thru the intake manifold on their way to the carburetor.

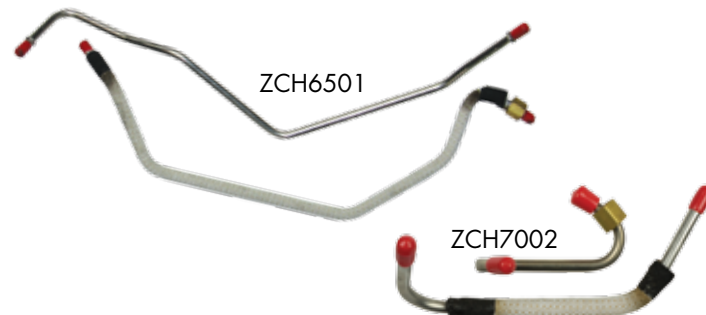

ADD "S" TO PART NUMBER FOR STAINLESS STEEL

ZCH6702.... 67-68..... 390 4 BBL GT
 ZCH6501 67-69..... 289-302, Enters Under Choke
 ZCH6802..... 68 428 P.I. with Tall Valve Covers
 ZCH6801 68-69..... 428 CJ, KR (Over Valve Covers)
 ZCH6901 69 351 W. Enters Under Choke
 ZCH6902..... 69 351 W. Enters Thru Choke Cover
 ZCH7001 70-73..... 351 C., 2 BBL
 ZCH7002.... 70-73..... 351 C., 4 BBL, with Autolite Carb.

WHEEL CYLINDERS

Wheel cylinders are priced individually. Hardware is not included.



WC51..... 67-68 Left & Right Rear, 13/16" Bore, 390
 WC93..... 67-69 Left Front, 1-1/18" Bore, 8 Cyl.
 WC94..... 67-69 Right Front, 1-1/18" Bore, 8 Cyl.
 WC95..... 67-69 Left Front, 1-3/32" Bore, 390
 WC96..... 67-69 Right Front, 1-3/32" Bore, 390
 WC64..... 67-73 Left Rear, 7/8" Bore, 8 Cyl., After 4/15/66
 WC65..... 67-73 Right Rear, 7/8" Bore, 8 Cyl., After 4/15/66
 WC93..... 70-72 Left Front, All Cars

COUGAR FUEL & TRANSMISSION LINES

FUEL PUMP TO CARB LINES

Fuel pump to carburetor lines connect the fuel pump to the carburetor. Brass blocks and fittings are included as noted. These lines are intended to work only with factory pump, motor, intake and carburetor combinations.

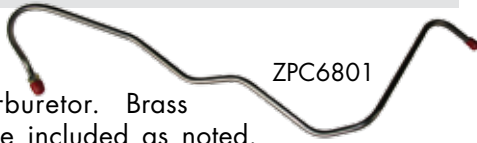

ADD "S" TO PART NUMBER FOR STAINLESS STEEL

ZPC6701.....67.....390, 4 BBL
ZPC6703.....67.....390, 2 BBL
ZPC6602.....67-68....289, 2 BBL or 4 BBL
ZPC6801.....68.....302, 4 BBL
ZPC6802.....68-70....390/428 4 BBL, P.I., C.J., or S.C. J.
ZPC6803.....68-70....302 or 351 W., 2 BBL
ZPC6901.....69.....351 W., 4 BBL
ZPC6902.....69-70....Eliminator with Boss 302
ZPC7001.....70-72....351 C., 4 BBL
ZPC7002.....70-73....429 C. J., with Spread Bore
ZPC7003.....70-73....429 S.C.J., with Holley
ZPC7004.....70-73....351 C., 2 BBL

MAIN FUEL LINES

Main lines carry fuel from the tank in the rear of the car to the fuel pump or rail in the front. They are available in 3/8" and 5/16" tubing based on factory specifications. Multiple piece sets are noted. Call for 1/2" lines.

ADD "S" TO PART NUMBER FOR STAINLESS STEEL

ZGL6712.....67...5/16", Early, (Runs In Tunnel).....1 Pc.
ZGL6713.....67...5/16", Late, (Runs By Rocker).....2 Pcs.
ZGL6812.....68...3/8", Staggered Shocks.....2 Pcs.
ZGL6813.....68...3/8", (w/o Staggered Shocks).....2 Pcs.
ZGL6912.....69...3/8".....2 Pcs.
ZGL7012.....70...3/8" 8 Cylinder.....2 Pcs.
ZGL7121.....71...3/8" Main Fuel Line
ZGL7122.....71...5/16" Fuel Vent Line

TRANSMISSION COOLER LINES

Transmission cooler lines are sold as pairs. Be sure to verify the type of transmission in your project before ordering. These lines are intended to work only with factory motor, transmission, and radiator combinations.

ADD "S" TO PART NUMBER FOR STAINLESS STEEL

ZTC6703....67-68.....C6, 8 Cylinder, Thru Early 68
ZTC6702....67-70.....C4, 8 Cylinder
ZTC6803....68-70.....C6, Late 68 Thru 70
ZTC6901....69-70.....351 W., FMX, Standard Cooling
ZTC6902....69-70.....351 W., FMX, H.D. Cooling
ZTC7001.....70.....351 C., FMX
ZTC7101....71-73.....C4, 8 Cylinder
ZTC7102....71-73.....FMX, 8 Cylinder

RETURN FUEL LINES

Return lines carry excess fuel from fuel pump or fuel filter back to the tank. Not all vehicles were equipped with a return line. They are typically made of 1/4" diameter tubing. Multiple piece sets are noted.

ZGL7123.....71.....3/16 Fuel Return Line - OE Steel
ZGL7123S.....71.....3/16 Fuel Return Line - Stainless

HOLLEY CARB FUEL LINES

These transfer tubes join the two float bowls on factory style Holley Carburetors.



ZHC6801....68-70...Holley, Auto Choke, 302 Boss, 428 - OE Steel
ZHC6801S..68-70...Holley, Auto Choke, 302 Boss, 428 - Stainless



FRONT BRAKE LINE KITS

Front brake line kits consist of all brake lines under the hood including the master cylinder to the distribution, combination or metering valve. The left & right front lines that run to the front flex hoses are also included. For vehicles with factory brake systems.

ADD "S" TO PART NUMBER FOR STAINLESS STEEL

GKT400140 Standard Drum.....	3 Pcs.
DBS410141 Mercury Club Coupe	6 Pcs.
GBS410041 Std. Drum, Complete Line Set...	6 Pcs.
GKT4601	. 46-48	... Standard Drum.....	4 Pcs.
GKT500150 Standard Drum.....	2 Pcs.
GKT6103	. 61-63	... Lincoln Continental	3 Pcs.
GKT650265 Lincoln Continental	4 Pcs.
GKT510151 All Cars.....	3 Pcs.
GKT530153 Standard Drum.....	2 Pcs.
GKT550155 Standard Drum.....	3 Pcs.
GKT550355 Crown Vic., Std. Drum	3 Pcs.
GKT550255 Montclair.....	3 Pcs.
GKT560156 Standard Drum.....	3 Pcs.
GKT560256 Power Brakes, Lincoln	3 Pcs.
GKT570157 Standard Drum.....	3 Pcs.
GKT570357 Std Drum, Retractable HT	3 Pcs.
GKT5702	. 57-58	... Fairlane, Standard Drum	3 Pcs.
GKT580168 Edsel Corsair	2 Pcs.
GKT580258 Power Drum, Retractable HT	3 Pcs.
GKT600160 Sunliner, Power Drum.....	3 Pcs.
GKT6103	. 61-63	... Lincoln Continental	3 Pcs.
GKT640164 Parkline.....	3 Pcs.
GKT650165 Power Drum, Wagon	3 Pcs.
GKT690169 Power Drum, Lincoln	12 Pcs.
GKT690469 Power Disc, Lincoln Mark III....	6 Pcs.
GKT690569 Power Disc, XL	6 Pcs.

WHEEL CYLINDERS



Wheel cylinders are priced individually. Hardware is not included.

WC10249-56 Left front, 1-1/8"
WC10349-56 Right Front, 1-1/8"
WC6249-68 Left Rear, S.W. & Conv. 15/16"
WC6349-68 Right Rear, S.W. & Conv. 15/16"
WC6449-69 Left Rear, All Exc. S.W. & Conv. 7/8"
WC6549-69 Right Rear, All Exc. S.W. & Conv. 7/8"
WC104 57 Left front, 1-1/8"
WC105 57 Right Front, 1-1/8"
WC104 59 Left Front, All Exc. Taxi, 1-1/8"
WC105 59 Right Front, All Exc. Taxi, 1-1/8"
WC60 59 Left Front, Police & Taxi
WC61 59 Right Front, Police & Taxi

DISTRIBUTOR VACUUM

GDV560156 368, 4 BBL	2 Pcs.
GDV560256 312/292, 4 BBL	2 Pcs.
GDV590159 8 Cylinder	
GDV600160 352 ci	
GDV640164 Parkline	

FRONT TO REAR BRAKE LINES

Front to rear brake lines go from the distribution, combination or metering valve along the length of the vehicle to the rear flex hose. Lines are manufactured in 1 or 2 pieces based on factory specifications.

ADD "S" TO PART NUMBER FOR STAINLESS STEEL

GIN400140 All Cars (No Rear Axle Lines), 2-Piece.
GIN4601	. 46-48	... All Cars, 2-Piece
GIN500150 All Cars
GIN510151 Hardtop
GIN550155 Hardtop
GIN550255 Convertible
GIN550355 Montclair
GIN560156 V-8, BBL
GIN560256 Convertible, Lincoln
GIN570157 Hardtop
GIN570257 Convertible, Fairlane
GIN580158 Edsel Corsair
GIN590159 Retractable, 3/16"
GIN600160 Sunliner, 2-Piece
GIN6102	. 61-63	... Lincoln Continental
GIN640164 Parkline Hardtop 2 Dr
GIN650165 Country Sedan Wagon, 2-Piece
GIN650365 Lincoln Continental, Disc/Drum
GIN690269 Power Disc, XL Convertible

REAR AXLE BRAKE LINES

Rear axle brake lines include a pair of lines that run across the rear axle housing. These lines connect the wheel cylinders or calipers to the flex hose in the middle of the rear end. These lines work with original housings that use factory brakes. Modifications such as rear disc brakes or narrowed rear ends will likely require special lines. Call for more information.

GRA4601 46 Pair - OE Steel.....	2 Pcs.
GRA4601S	... 46 Pair - Stainless.....	2 Pcs.
GRA5001 50 Pair - OE Steel.....	2 Pcs.
GRA5001S	... 50 Pair - Stainless.....	2 Pcs.
GRA5101 51 All Cars - OE Steel.....	2 Pcs.
GRA5101S	... 51 All Cars - Stainless.....	2 Pcs.
GRA5301 53 Pair - OE Steel.....	2 Pcs.
GRA5301S	... 53 Pair - Stainless.....	2 Pcs.
GRA5501 55 Pair - OE Steel.....	2 Pcs.
GRA5501S	... 55 Pair - Stainless.....	2 Pcs.

VACUUM WIPER LINES

ADD "S" TO PART NUMBER FOR STAINLESS STEEL

GVW5501	... 55 All Cars	
GVW5502	... 55 Montclair	
GVW5901	... 59 All Cars.....	2 Pcs.

VACUUM PUMP LINES

GVP5601 56 Vacuum Pump Line - OE Steel
GVP5601S 56 Vacuum Pump Line - Stainless

FULL SIZE FORD BRAKE, FUEL & TRANS LINES

FRONT BRAKE FLEX HOSES

Front flex hoses provide a flexible connection from the body or frame to the front calipers or wheel cylinders as they move during suspension travel. Hoses are available in O.E. rubber. All of our hoses are D.O.T. approved. Hoses are priced individually.

FH113..... 54-56 All
FH78.....57 All
FH72.....58 All
FH69..... 59-64 All

REAR BRAKE FLEX HOSES

Rear flex hoses carry brake fluid between the body of the car and the rear. Hoses are available in O.E. rubber. 'T' blocks are attached whenever factory correct. All of our hoses are D.O.T. approved. Prices are per hose.

FH187.....52-55.....All Except Station Wagon & Convertible
FH114.....55-56.....Station Wagon & Convertible
FH188.....56-58.....All Except Skyliner & Convertible
FH78..... 57Skyliner
FH187.....57-58.....Station Wagon
FH72..... 58Skyliner
FH72.....59-64.....All

FUEL PUMP TO CARB LINES

Fuel pump to carburetor lines connect the fuel pump to the carburetor. Brass blocks and fittings are included as noted. These lines are intended to work only with factory pump, motor, intake and carburetor combinations.

ADD "S" TO PART NUMBER FOR STAINLESS STEEL

GPC5501.....55 Montclair
GPC5601.....56 368, 4 BBL, Lincoln
GPC5601.....56 V-8, 4 BBL, Excl. Lincoln
GPC5801.....58 Edsel Corsair, 440ci
GPC5901.....59 8 Cylinder
GPC6001.....60 352 ci, 4 BBL
GPC6402.....64 Parkline

VACUUM LINES

ADD "S" TO PART NUMBER FOR STAINLESS STEEL

GFV5501 55 Montclair Fuel Vent Line
GTV5801 58 Edsel Corsair 440ci, 2-Piece
GTV6001 60 Big Block
GBV6001 60 Brake Vacuum
GCH6001 60 Choke Tube
GFV6001 60 Fuel Tank Vent
GTV6102 61-63.... Lincoln Continental
GTV6401 64 Parkline Trans. Vacuum Line
GTV6402 64 Parkline Trans. Vent Line

MAIN FUEL LINES

Main lines carry fuel from the tank in the rear of the car to the fuel pump or rail in the front. 3/8" or 5/16" based on factory specs. Multiple piece sets are noted. Call for 1/2" lines.

ADD "S" TO PART NUMBER FOR STAINLESS STEEL

GGL4001 40 Front to Rear Main Line
GGL5001 50 Front to Rear Main Line, 2-Piece
GGL5301 53 3/8" Main Line
GGL5501 55 Convertible
GGL5502 55 5/16" Hardtop
GGL5503 55 3/8" Montclair, 2-Piece
GGL5601 56 5/16" Main Line, Excl. Lincoln
GGL5602 56 5/16" Main Line, Lincoln
GGL5701 57 5/16" Main Line
GGL5702...57-58... 5/16" Fairlane
GGL5703 57 Retractable Fuel Line
GGL5801 58 Edsel Corsair 440ci
GGL5901...59-60... 5/16" Main Line
GGL6001 60 5/16" Main Line
GGL6103...61-63 .. 3/8" Main Line, Lincoln Continental
GGL6104...61-63... 3/16" Return, Lincoln Continental
GGL6401 64 Parkline Hardtop Main Line
GGL6501 65 3/8" Main, Lincoln Cont, 2-Piece
GGL6502 65 3/16" Fuel Line, Lincoln Cont.
GGL6901 69 Lincoln
GGL6903 69 3/8", XL Convertible

TRANSMISSION COOLER LINES

Transmission cooler lines are sold as pairs. Be sure to verify the type of transmission in your project before ordering. These lines are intended to work only with factory motor, transmission, and radiator combinations.

ADD "S" TO PART NUMBER FOR STAINLESS STEEL

GTC5701 57 Ford-O-Matic
GTC5802 58 Mercury Montclair, 2-Piece
GTC5801 58 Edsel Corsair 440 ci
GTC5901 59 Retractable
GTC6401 64 Parkline

INTAKE VACUUM LINES

GIV5501 55 All Cars - OE Steel
GIV5501S 55 All Cars - Stainless

TRUCK TRANS COOLER LINES

Intended for factory motor, transmission, and radiator combinations. If your system is not 100% stock, call us for options.

ADD "S" TO PART NUMBER FOR STAINLESS STEEL

TRS7379 .. 73-79 ... Aux. Transmission Cooler Line
TTC7901 .. 77-79 ... F-150, 2WD, C6.....2 Pcs.
TTC860086 F250, C6 w/ Cooler4 Pcs.
TTC9202 .. 92-97 ... Ford F250, 7.5L 4x4 E40D4 Pcs.

COMPLETE BRAKE SETS

ADD "S" TO PART NUMBER FOR STAINLESS STEEL

TBS500350Complete F-100 Brake Kit5 Pcs.
TBS520152Complete Brake Line Set5 Pcs.
GTS570157Complete Brake Line Set with Clutch Line7 Pcs.
TBS650165F100, 2wd, Longbed6 Pcs.
TBS670167Econoline Van Complete Set8 Pcs.
TBS860186Complete Brake Line Set7 Pcs.
TBS865086F250, 4WD, 8 ft. Bed6 Pcs.
TBS870587Power Disc, F350, 4WD8 Pcs.
TBS890289F250, 4WD, 8' Bed, Diesel6 Pcs.

FRONT BRAKE LINE KITS

Front brake line kits include the master cylinder to the distribution, combination or metering valve, & the left and right front lines that run to the front flex hoses. For vehicles with factory brake systems. If you have a disc conversion or aftermarket valve, call our technical staff for help determining the correct line set

ADD "S" TO PART NUMBER FOR STAINLESS STEEL

TKT3901391/2 Ton3 Pcs.
TKT530153F100, 6 Cylinder2 Pcs.
TKT5511	..55-56	..1/2Ton, Standard Drum2 Pcs.
TKT6602	..66-75	..Manual Drum9 Pcs.
TKT690369F100, 2WD4 Pcs.
TKT7010701/2Ton, 2WD, Standard Drum	...4 Pcs.
TKT7305731/2 Ton, 2 WD, Disc4 Pcs.
TKT770877Power Disc, 250, 4WD4 Pcs.
TKT7804	..73-79	..Power Disc, 2 WD, Short Bed4 Pcs.
TKT8201821/2 Ton, Power Disc4 Pcs.
TKT930293F150 Lightning 1/2 Ton4 Pcs.
TKT9306	..93-96	..F150 1/2 Ton, Xtra Cab 6' Bed	..4 Pcs.
TKT980198F150 Longbed Disc/Drum4 Pcs.
TKT980298Ranger Supercab 4WD ABS3 Pcs.

MAIN FUEL LINES

Main lines carry fuel from the tank in the rear of the car to the fuel pump or rail in the front. 3/8" and 5/16" factory sizes. Multiple piece sets are noted. Call for 1/2" lines.

ADD "S" TO PART NUMBER FOR STAINLESS STEEL

TGL4601465/16" Main Line
TGL5701575/16" Main Line
TGL6408645/16" F100, 2-Piece
TGL690369F100, 2WD, 3 Spd Main Fuel Line
TGL7010701/2 Ton, 2WD, Main Fuel Line
TGL7803	..76-79	..1/4" F-150 2WD, Short Bed
TGL7804	..76-79	..3/8" 2 WD, Short Bed
TGL797979Bronco, Main Fuel Line

VACUUM LINES

ADD "S" TO PART NUMBER FOR STAINLESS STEEL

GDV570157Distributor Vacuum Line	15.75
TTV730173-79F150 Transmission Vacuum Line	40.95
GTV860186Transmission Vacuum Line	40.95

FRONT TO REAR BRAKE LINES

Front to rear brake lines go from the distribution, combination or metering valve along the length of the vehicle to the rear flex hose. Manufactured in 1 or 2 pieces based on factory specs.

ADD "S" TO PART NUMBER FOR STAINLESS STEEL

TIN3901391/2 Ton2 Pcs.
TIN530153F100 6 Cylinder	
TIN5511	...55-56	...1/2 Ton, 6' Bed	
TIN6602	...66-75	...Manual Drum	
TIN690169F100, 2WD2 Pcs.
TIN7010701/2 Ton, 2WD, Shortbed2 Pcs.
TIN7305731/2 Ton, 2WD, Disc, Longbed	..2 Pcs.
TIN7303	...73-79	...F150-F350, 2WD, Super Cab Long Bed2 Pcs.
TIN7803	...76-79	...Power Disc, 2WD, Short Bed	...2 Pcs.
TIN797979Bronco Front to Rear Brake Line	
TIN8201821/2 Ton, 8' Bed2 Pcs.
TIN9302	...93-96	...F250/F350, 8' Bed2 Pcs.
TIN9306	...93-96	...F150 1/2 Ton, Xtra Cab, 6' Bed2 Pcs.
TIN930193F150 Lightning 1/2 Ton2 Pcs.
TIN970197F350, 4WD2 Pcs.
TIN980298F150 XLT Longbed Disc/Drum	
TIN980398Ranger Supercab 4WD ABS2 Pcs.
TIN2004004WD Superduty Crewcab	
TIN200900F350 Ext. Cab, 4WD Dually, 8' Bed	
TIN201100Ranger XLT, Super Cab, Step Side	

REAR AXLE BRAKE LINES

Rear axle brake lines include a pair of lines that run across the rear axle housing & connect the wheel cylinders or calipers to the flex hose in the middle of the rear end. (For original housings that use factory brakes). Call if you have modifications such as rear disc brakes or narrowed rear ends.

ADD "S" TO PART NUMBER FOR STAINLESS STEEL

TRA5511	..55-56	..9", Rear Axle Lines2 Pcs.
TRA6602	..68-77	..Bronco2 Pcs.
TRA690169F100, 2WD, 3 Spd2 Pcs.
TRA7010701/2 Ton, 2 WD Rear Axle2 Pcs.
TRA7305731/2 Ton, 2 WD2 Pcs.
TRA7804	..76-79	..F-150, 2 WD, Standard Duty2 Pcs.
TRA797979Bronco Rear Axle Brake Lines2 Pcs.
TRA8201821/2 Ton2 Pcs.
TRA9302	..93-94	..F250/F350 Sterling2 Pcs.
TRA930693F150 1/2 Ton & Lightning2 Pcs.
TRA980298Ranger Supercab 4WD ABS2 Pcs.

FUEL PUMP TO CARB LINES

Fuel pump to carburetor lines connect the fuel pump to the carburetor. Brass blocks and fittings are included as noted. For factory pump, motor, intake and carburetor combinations.

GPC570157Fuel Pump to Carb. Line - OE Steel
GPC5701S57Fuel Pump to Carb. Line - Stainless

MOPAR A-BODY BRAKE LINES

FRONT BRAKE LINE KITS

Front brake line kits consist of all brake lines under the hood. This includes the master cylinder to the distribution, combination or metering valve. The left & right front lines that run to the front flex hoses are also included. Call for individual component pricing. These line kits are for vehicles with factory brake systems.

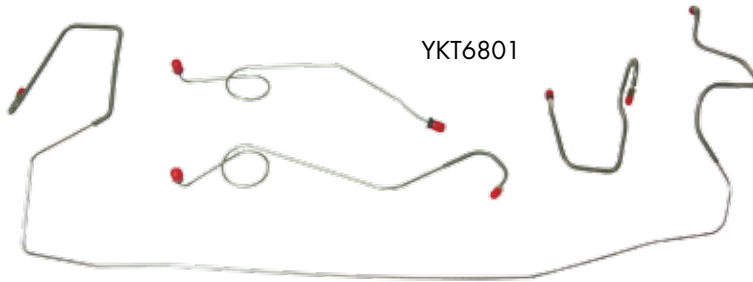

ADD "S" TO PART NUMBER FOR STAINLESS STEEL

YKT6201	62	Manual Drum.....	3 Pcs.
YKT6301	63	Manual Drum.....	3 Pcs.
YKT6501 ..	64-65 ...	Standard Brakes.....	3 Pcs.
YKT6601	66	Standard Brakes.....	3 Pcs.
YKT6701	67	Standard Brakes.....	4 Pcs.
YKT6702	67	Power Brakes.....	4 Pcs.
YKT6801 ..	68-72 ...	Standard Brakes.....	4 Pcs.
YKT6802 ..	68-72 ...	Power Brakes.....	4 Pcs.
YKT7301	73	Standard Brakes.....	4 Pcs.
YKT7302	73	Power Brakes.....	4 Pcs.
YKT7501	75	Standard Drum.....	4 Pcs.
YKT7501	75	Duster, Manual Disc.....	4 Pcs.

REAR AXLE BRAKE LINES

Rear axle brake lines include a pair of lines that run across the rear axle housing. These lines connect the wheel cylinders or calipers to the flex hose in the middle of the rear end. These lines work with original housings that use factory brakes. Modifications such as rear disc brakes or narrowed rear ends will likely require special lines. Call for more information.



ADD "S" TO PART NUMBER FOR STAINLESS STEEL

YRA6201	62	Dart
YRA6502 ..	63-66 ...	All Cars
YRA6701 ..	67-69 ...	7-1/4"
YRA6702 ..	67-69 ...	8-3/4" Flex Pumpkin
YRA7001 ..	70-72 ...	8-3/4" Flex Axle Tube
YRA7003 ..	70-72 ...	7-1/4"
YRA7301	73	8-3/4"
YRA7302	73	9-1/4"
YRA7303 ..	73-75 ...	8-1/4"
YRA7501	75	Swinger
YRA7503	75	Duster

FRONT TO REAR BRAKE LINES

Front to rear brake lines go from the distribution, combination or metering valve along the length of the vehicle to the rear flex hose. Lines are manufactured in 1 or 2 pieces based on factory specifications.



ADD "S" TO PART NUMBER FOR STAINLESS STEEL

YIN6201	62	All Cars	
YIN6301	63	All Cars	
YIN6302	63	4 Door	
YIN6502 ..	64-65 ...	All Cars, Except 4 Door	
YIN6504	65	Dart, 4 Door	
YIN6602	66	All Cars	
YIN6603	66	Custom Convertible	
YIN6701 ..	67-70 ...	Dart & Dart Swinger, Drum Brakes ¹	
YIN6702 ..	67-70 ...	Dart & Dart Swinger, Disc ^{1,2}	2 Pcs.
YIN6703 ..	67-70 ...	108" Wheel Base Cars, Drum ^{1,2}	2 Pcs.
YIN6704 ..	67-70 ...	108" Wheel Base Cars, Disc ^{1,2}	2 Pcs.
YIN6701 ..	71-72 ...	Dart & Dart Swinger, All Cars ¹	
YIN6703 ..	71-72 ...	108" Wheel Base Cars, All ¹	
YIN7301	73	111" Wheel Base Cars ¹	
YIN7302	73	108" Wheel Base Cars ¹	
YIN7401	74	Dart, with Power Disc	
YIN7501	75	Swinger, Standard Drum	

1 67-73 Dart/Swinger & 71-73 Scamp are 111" WB All others are 108"
2 Uses RMB6801 hold-off valve

FRONT BRAKE FLEX HOSES

Front flex hoses provide a flexible connection from the body or frame to the front calipers or wheel cylinders as they move during suspension travel. Choose between O.E. rubber or braided stainless steel. All hoses are D.O.T. approved. Priced individually.

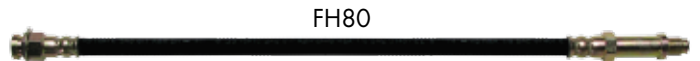

ADD "S" TO PART NUMBER FOR STAINLESS STEEL

FH91	63-66	with 9" Drums
FH80	65-69	with 10" Drums
FH88	70-72	All Cars
FH111	73-76	Disc

REAR BRAKE FLEX HOSES

Rear flex hoses carry brake fluid between the body of the car and the rear. Hoses are available in O.E. rubber and braided stainless steel. 'T' blocks are attached whenever factory correct. All of our hoses are D.O.T. approved. Prices are per hose.

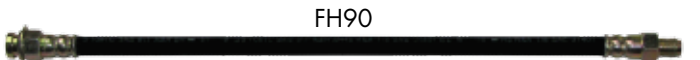

ADD "S" TO PART NUMBER FOR STAINLESS STEEL

FH89	65-69	All Cars
FH90	70-71	All Cars
FH86	72-76	All Cars

FRONT DRUM LINES

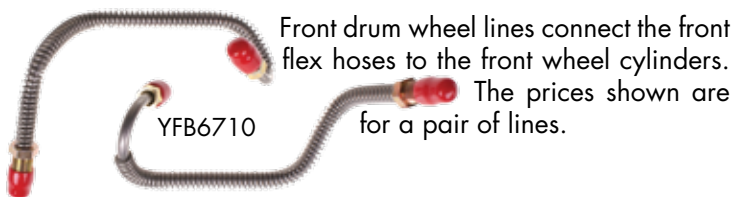

Front drum wheel lines connect the front flex hoses to the front wheel cylinders. The prices shown are for a pair of lines.

YFB6710

ADD "S" TO PART NUMBER FOR STAINLESS STEEL

- YFB6708 ... 67-74 ... Wheel Cylinder Lines, 2-Piece with 9" Drums, with 3/8" Fitting
- YFB6709 ... 67-74 ... Wheel Cylinder Lines, 2-Piece with 9" Drums, with 3/8" Fitting One End, Long 3/8" Fitting with Bubble Flare End
- YFB6710 ... 67-72 ... Wheel Cylinder Lines, 2-Piece with 10" Front Drums

WHEEL CYLINDERS

Wheel cylinders are priced each. Hardware is not included.



- WC79.....62-69..... Left Front, 10" Brakes, 1-1/8"
- WC80.....62-69..... Right Front, 10" Brakes, 1-1/8"
- WC83.....63-66..... Right Front, 9" Brakes, 1"
- WC81.....63-72..... Rear, 9" Brakes, 13/16"
- WC73.....65-69..... Rear, 10" Brakes, 15/16"
- WC68.....70-72..... Right Front, 10" Brakes, 1-3/16"
- WC69.....70-72..... Left Front, 10" Brakes, 1-3/16"
- WC74.....70-76..... Rear, 10" brakes, 15/16"
- WC88.....73-76..... Left Front, 9" Brakes, 1-1/16"
- WC89.....73-76..... Right Front, 9" Brakes, 1-1/16"

BRAKE LINE CLIPS

Brake line clip sets contain all the clips needed to fasten the brake tubes to the frame or body of the car. Individual clips and fasteners are available on pages 284-285.



ACS002

- ACS002 67-74 Brake Line Clip Set
- ACS011 67-74 3/8" Fuel Line Clips
- ACS012 67-74 5/16" Fuel Line Clips
- ACS010 70 5/16" & 5/16" Fuel Line Clips
- ACS013 72-75 5/16" & 1/4" Fuel Line Clip
- ACS014 72-75 3/8" & 1/4" Fuel Line Clips

HOSE BLOCKS

Breather bolts vent the rear end and hold the distribution block to the housing. Some cars have a block crimped directly to the hose. Others use the screw on blocks listed here. Verify the specifics of your application before ordering.

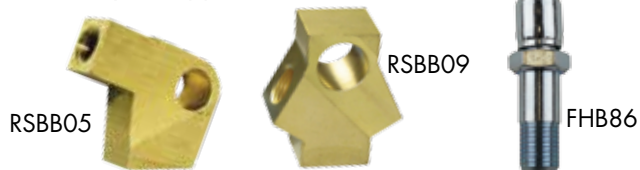

- FHB86 62-76 Breather Bolt
- RSBB09 62-66 "Y" Block on Rear Axle
- RSBB49 67-69 "Y" Block on Rear Axle
- RSBB09 70-72 "Y" Block on Rear Axle
- RSBB05 72-76 "L" Block on Rear Axle

DISC CALIPER LINES

Front disc caliper lines connect the front flex hoses to the calipers. They were typically used on 4 piston calipers in the late 1960's and early 1970's.

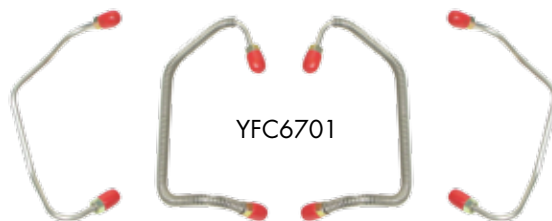

YFC6701

- YFC6701 66-72 Kelsey-Hayes Caliper Lines - OE Steel ... 4 Pcs
- YFC6701S ... 66-72 Kelsey-Hayes Caliper Lines - Stainless ... 4 Pcs

VALVES & BLOCKS

We offer a full line of metering blocks, proportioning valves, distribution blocks and combination valves for factory drum and disc brake applications.

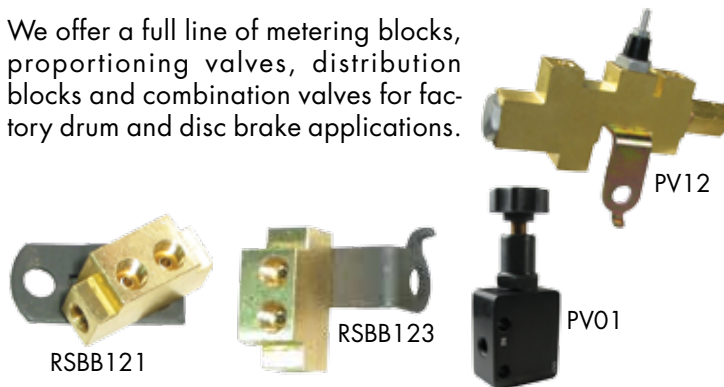

- RSBB121 62-64 Dual Master Conversion Block
- RSBB123 65-66 Dual Master Conversion Block
- PV01 All Adjustable Proportioning Valve
- PV11 67-75 Disc Brake Distribution Block, Used with Separate Proportioning Valve
- PV11 67-75 Drum Brake Distribution Block
- PV12 71-74 A-Body Disc Combo Valve, Single Valve Systems

MOPAR A-BODY E-BRAKE CABLES

E-BRAKE CABLES

Parking brake cable sets contain all the individual cables & hardware needed to restore the system. Front, rear, & intermediate cables are also sold individually while supplies last. Sold in O.E. mild steel and stainless steel. See our rear disc brake cables if you have a rear disc conversion.

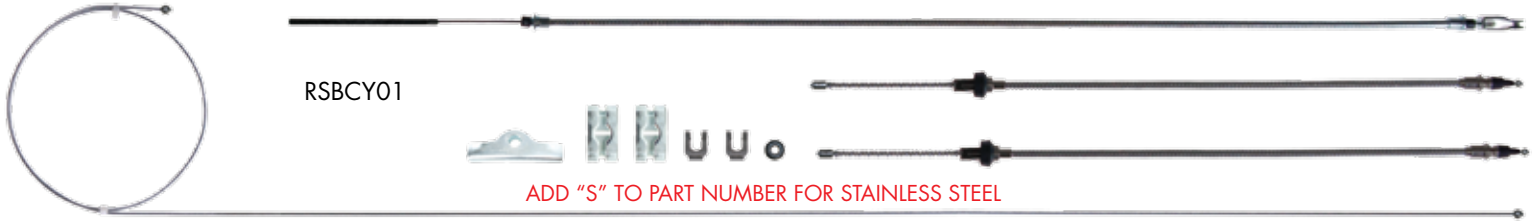

• Front Brake Cables

- EBC7013... 63-66 ...A-Body Plymouth
- EBC7034... 63-66 ...Dodge
- EBC7012... 67-74 ...108" Wheelbase, w/o Intermediate
- EBC7016... 67-74 ...111" Wheelbase
- EBC7036... 67-74 ...111" Wheelbase, with Intermediate

• Rear Brake Cables

- EBC9037... 63-66 ...Dodge
- EBC9041... 63-66 ...Plymouth
- EBC9016... 64-74 ...with Intermediate
- EBC9012... 67-71 ...108" WB, without Intermediate
- EBC9039... 67-74 ...111" WB, without, Intermediate Short
- EBC9040... 67-74 ...111" WB, without Intermediate Long

• Intermediate Brake Cables

- EBC8021... 63-66 ...A-Body Plymouth
- EBC8029... 63-66 ...Dodge
- EBC8012... 67-74 ...108" Wheelbase
- EBC8013... 67-74 ...111" Wheelbase

• E-Brake Cable Kits

- RSBCY01 ... 63-65 ...Plymouth
- RSBCY02 ... 63-65 ...Dodge
- RSBCY03 ... 67-71 ...w/o Intermediate, 108" Wheelbase
- RSBCY04 ... 72-74 ...with Intermediate, 108" Wheelbase
- RSBCY13 ... 67-71 ...w/o Intermediate, 111" Wheelbase
- RSBCY14 ... 72-74 ...with Intermediate, 111" Wheelbase

• E-Brake Hardware

- EBH3004.... 63-66 ... Center to Rear Converter
- EBH3006.... 63-66 ... Center Pull
- EBH1007.... 63-71 ... Black Cable Clip
- EBH1008.... 63-71 ... Jam Nut with Collar
- EBH3003.... 67-71 ... Silver Center Pull
- EBH3001.... 72-74 ... Olive Green Center Pull
- EBH3005.... 72-74 ... Fits All Cars - Equalizer
- EBH3004.... 72-74 ... Center to Rear Silver Connector
- EBH2029.... 72-74 ... 13 1/8 Hook
- EBH1001.... 72-74 ... Jam Nut

TRANSMISSION COOLER LINES

Transmission cooler lines are sold as pairs. Be sure to verify the type of transmission in your project before ordering. These lines are intended to work only with factory motor, transmission, and radiator combinations.



ADD "S" TO PART NUMBER FOR STAINLESS STEEL

- YTC6001 60..... Torque Flite.....2 Pcs.
- YTC6301 63..... 904.....3 Pcs.
- YTC6401 ... 64-68 ... Slant 6 with 904
- YTC6502.... 64-66 ... with V-8
- YTC6402..... 64..... V-8 Torque Flite
- YTC6403..... 64..... Dart, 225 with 904
- YTC6701 ... 67-69 ... 727 with Loop 12" From Radiator
- YTC6706.... 69-75 ... Slant 6 with 904
- YTC7204.... 67-72 ... 318 with 904
- YTC6901 ... 69-71 ... 340 ci with 727
- YTC7001 ... 69-72 ... 727 with Loop Near Radiator
- YTC720172-73 ... 340 with 727
- YTC7401 74..... Dart, 318 with 904
- YTC7501 75..... Swinger

BOOSTER/MASTER COMBOS

Buy your Booster & Master together at a discounted price. These brake boosters are a direct bolt on for manual brake cars. If you have factory power brakes, you will need to modify your firewall.



G800110



J800110

- G800110..... 8" Dual Booster - 1-1/16" Bore Master, Gold
- J800110..... 8" Dual Booster - 1-1/16" Bore Master, Chrome
- G800115..... 8" Dual Booster - 15/16" Bore Master, Gold
- J800115..... 8" Dual Booster - 15/16" Bore Master, Chrome

MOPAR A-BODY BOOSTERS & MASTER CYLINDERS

MASTER CYLINDERS

All master cylinders are completely new units with no core charge. A deep cylinder pocket with a removable plug provides compatibility with manual brakes as well as power-assisted applications.



- DBMC10 62-76 1-1/16" Bore Diameter
- DBMC10C 62-76 1-1/16" Bore Diameter Chrome
- DBMC15 62-76 1-5/16" Bore Diameter
- DBMC15C 62-76 1-5/16" Bore Diameter Chrome

BRAKE BOOSTERS

Boosters pack a lot of punch in a small, sleek package. Dual diaphragm versions provide 25%-35% more assist than their single diaphragm equivalent. The 8" dual is our most popular for clearing big blocks while providing plenty of assist for two or four wheel disc brake systems. These brake boosters are a direct bolt on for manual brake cars. If you have factory power brakes, you will need to modify your firewall.



- RPB8001 8" Dual Diaphragm with High Rise Bracket, Gold
- RPB8001C 8" Dual Diaphragm with High Rise Bracket, Chrome

MAIN FUEL LINES

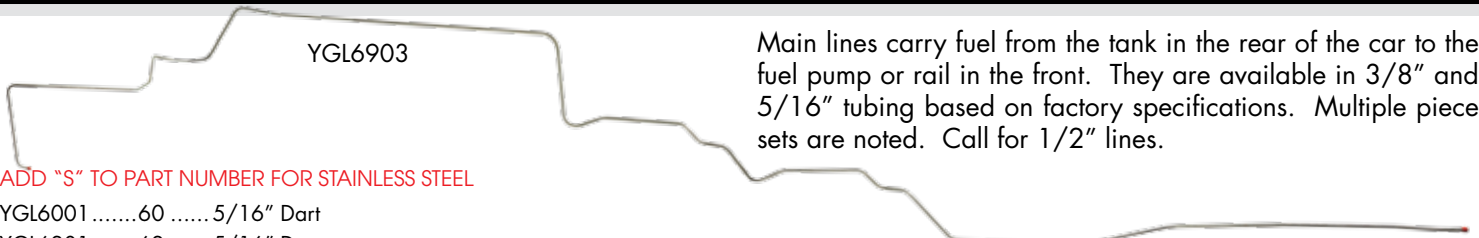

Main lines carry fuel from the tank in the rear of the car to the fuel pump or rail in the front. They are available in 3/8" and 5/16" tubing based on factory specifications. Multiple piece sets are noted. Call for 1/2" lines.

ADD "S" TO PART NUMBER FOR STAINLESS STEEL

- YGL600160 5/16" Dart
- YGL620162 5/16" Dart
- YGL630163 5/16" Dart
- YGL6501 64-66 5/16" Main Line
- YGL6502 64-66 3/8" Main Line
- YGL6701 67-68 5/16" Dart
- YGL6702 67-68 5/16" Barracuda or Valiant
- YGL6703 67-68 3/8" Dart
- YGL6704 67-68 3/8" Barracuda or Valiant
- YGL690269 5/16" Barracuda
- YGL690469 3/8" Barracuda

- YGL6901 69-72 5/16" Dart
- YGL6903 69-72 3/8" Dart
- YGL6902 69-72 5/16" Valiant/Duster
- YGL6904 69-72 3/8" Valiant/Duster
- YGL7301 72-73 5/16" Dart & Dart Swinger, Scamp
- YGL730473 3/8" Dart Sport, Duster, Valiant
- YGL7302 73-74 5/16" Dart Sport, Duster, Valiant
- YGL7303 73-74 3/8" Dart & Dart Swinger
- YGL750175 Swinger, Main

RETURN FUEL LINES

Return lines carry excess fuel from fuel pump or fuel filter back to the tank. Not all vehicles were equipped with a return line. Typically made of 1/4" diameter tubing. Multiple piece sets are noted.

- YGL720672 1/4" All - OE Steel2 Pcs.
- YGL7206S72 1/4" All - Stainless2 Pcs.
- YGL7306 73-74 1/4" Duster/Scamp - OE Steel2 Pcs.
- YGL7306S 73-74 1/4" Duster/Scamp - Stainless2 Pcs.
- YGL750275 1/4" Swinger - OE Steel
- YGL7502S75 1/4" Swinger - Stainless
- YGL750475 1/4" Dart - OE Steel2 Pcs.
- YGL7504S75 1/4" Dart - Stainless2 Pcs.

VAPOR RETURN LINES

Emission control systems use these 5/16" lines to handle fuel vapors. Some vehicles use a single front to rear line. Others utilize a charcoal canister and require 3 or 4 additional small lines. Multiple piece sets are noted.

YGL7105 CLOSE UP VIEW

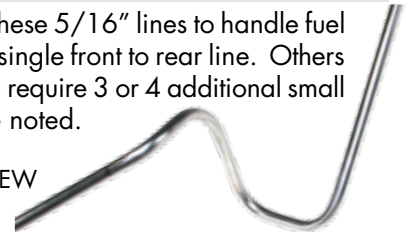

- YGL7104 71 5/16" Scamp - OE Steel 2 Pcs.
- YGL7104S 71 5/16" Scamp - Stainless 2 Pcs.
- YGL7105 71 5/16" Demon - OE Steel 2 Pcs.
- YGL7105S 71 5/16" Demon - Stainless 2 Pcs.
- YGL7205 72 5/16" Demon - OE Steel 2 Pcs.
- YGL7205S 72 5/16" Demon - Stainless 2 Pcs.
- YGL7305 71-72 .. 5/16" Scamp & Dart Swinger - OE Steel .. 2 Pcs.
- YGL7305S .. 71-72 .. 5/16" Scamp/Dart Swinger - Stainless .. 2 Pcs.

MOPAR A-BODY FUEL & SUSPENSION

FUEL TANKS

Fuel tanks are constructed of Ni-Terne steel. Hardware is not included.



YFT6301

YFT6701

- YFT6870.....68-70... without ECS - Fuel Tank
- YST687068-70... Fuel Tank without ECS, with Strap
- YFT7106.....71-76... Late with ECS, 1 Vent on Front
- YST710671-76... Late with ECS, 1 Vent on Front, with Strap

CARBURETOR LINES

Fuel pump to carburetor lines connect the fuel pump to the carburetor. Brass blocks and fittings are included as noted. These lines are intended to work only with factory pump, motor, intake and carburetor combinations.

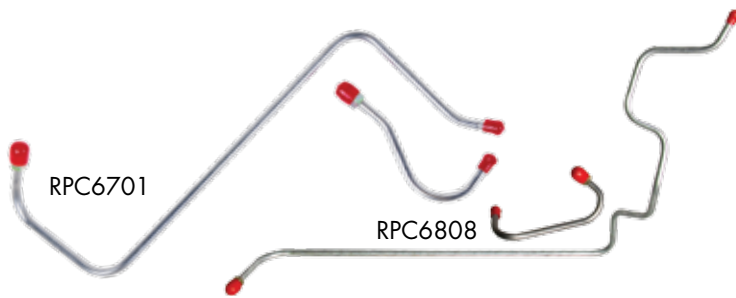

ADD "S" TO PART NUMBER FOR STAINLESS STEEL

- RPC6201 62 318 with 2 BBL..... 2 Pcs.
- RPC6204 62 318 with 4 BBL..... 2 Pcs.
- RPC6406 64 Slant 6, 225 2 Pcs.
- RPC6501 65 225 ci
- RPC6605 66 273 ci
- RPC6701 67-72 273, 318 with 2 BBL
- RPC6806 67-72 340 with Carter AVS..... 2 Pcs.
- RPC6807 67-72 383 with Carter AVS..... 2 Pcs.
- RPC6808 67-72 400, 440 with Thermoquad..... 2 Pcs.
- RPC6809 67-72 383, 440 with Single Inlet Holley
- RPC6906 69 225 Slant 6 2 Pcs.
- RPC7001 70-72 440 with Carter AVS, 4 BBL..... 2 Pcs.
- RPC6805 71 340 with Carter T-Quad 2 Pcs.
- RPC7101 71 Dart Sport, Weber 2 BBL
- RPC7106 71 225 Slant 6 2 Pcs.
- RPC7202 72 340 with Carter T-Quad
- RPC7204 72 318, 4 BBL
- RPC7306 73-76 360 ci 2 Pcs.

SUSPENSION KITS

COMING
IN 2017

Standard rubber kits meet O.E. specifications. Pre-packaged kits offer huge savings over individual suspension parts. Most kits include the following:

- Lower Ball Joints (2)
- Upper Ball Joints (2)
- Lower Ctrl. Arm Bushings (4)
- Upper Ctrl. Arm Bushings (4)
- Strut Rod Bushings (2)
- Tie Rod Adj. Sleeves (2)
- Outer Tie Rods (2)
- Inner Tie Rods (2)



RSK730173-76..... Front Rebuild Kit, 20 Pcs.

FUEL SENDING UNITS

Sending units include floats, gaskets and snap rings where applicable. Our fuel senders are made of stainless steel and operate on the same ohm range as factory gauges.



- YSU6301 63-76 5/16" Main Line
- YSU6321 63-76 1/2" Main Line
- YSU6901 69-74 3/8" Main Line
- YSU6921 69-74 1/2" Main Line

FUEL TANK VENT LINES

Fuel tank vent lines allow the air inside the fuel tank to escape as it is filled with fuel. They also prevent pressure from building up due to temperature changes.

- YFV6306 63-66 A-Body Fuel Tank Vent Line - OE Steel
- YFV6306 63-66 A-Body Fuel Tank Vent Line - Stainless



SUSPENSION COMPONENTS

**COMING
IN 2017**

UPPER & LOWER BALL JOINTS



XK781.....73-76..... Lower, Right Hand, with Steering Arm
 XK783.....73-76..... Lower, Left Hand, with Steering Arm
 XK772.....73-76..... Upper

INNER & OUTER TIE RODS & SLEEVES



XES319L..... 63-69 Inner
 XES319R 63-69 Outer
 XES401L..... 70-76 Inner
 XES401R 70-76 Outer
 XES319S 63-76 Adjusting Sleeve

CONTROL ARMS

**COMING
IN 2017**



UCA6076..... 73-76 Upper Control Arms, Stock

SWAY BAR LINK KITS



XK5255.....73-76..... All

UPPER & LOWER CONTROL ARM BUSHING KITS



XK408.....63-76..... Upper
 XK791.....63-76..... Lower

SWAY BAR BUSHING



XK5241.....73-76..... All

STRUT ROD BUSHING

XK7068.....73-76..... All



AXLE FLANGE DIAGRAMS

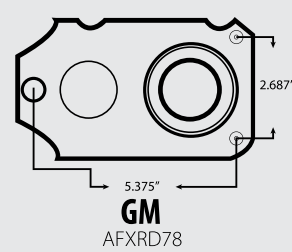
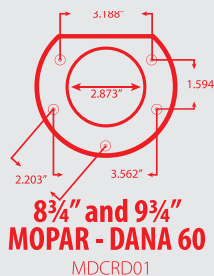
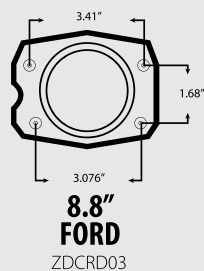
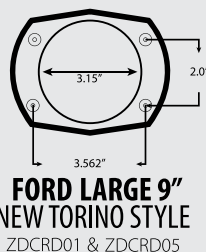
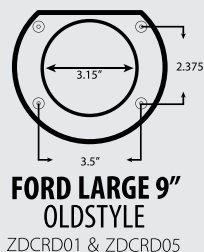
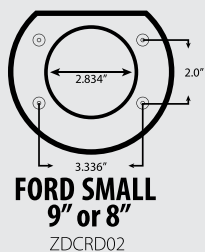
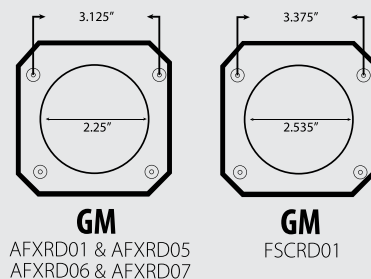
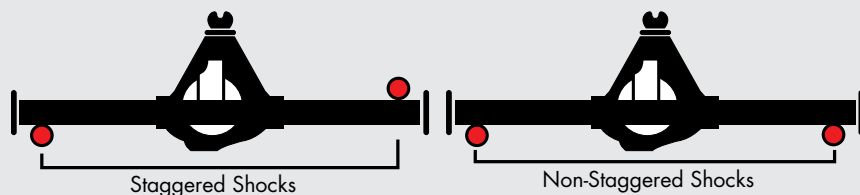

MOPAR A-BODY FRONT DISC CONVERSIONS

**STREET
SERIES**

U.S.A. Made
TIMKEN Bearings

FRONT DISC BRAKE CONVERSION KITS

FITS +15" WHEELS WITH A 5 X 4.5" BOLT PATTERN

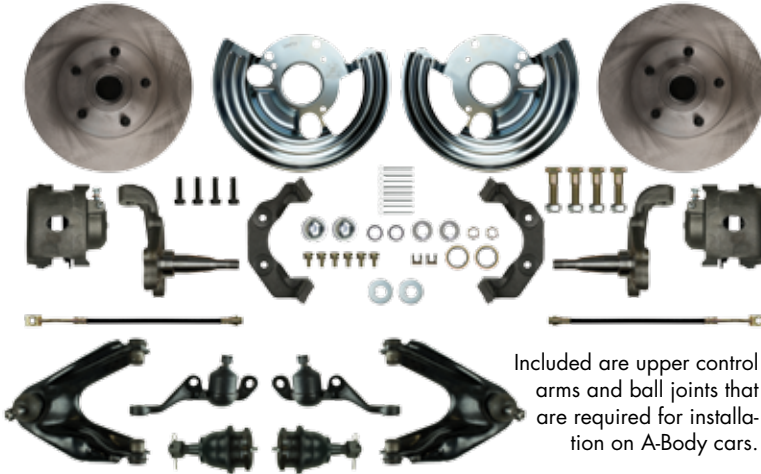

Included are upper control arms and ball joints that are required for installation on A-Body cars.

AT-THE-WHEEL FRONT KITS

FRONT CONVERSIONS INCLUDE:

- 11" Rotors (5 x 4.5")
- Forged Spindles
- Timken Bearings
- New Calipers
- Caliper Brackets
- Organic Pads
- Flex Hoses & Hardware
- Valve Bracket & Hardware
- Banjo Bolts & Copper Washers
- Dust Caps
- Castle Nuts & Pins
- Washers
- Grease Seals
- Steering Arm Bolts
- 8" Dual Power Booster
- Adjustable Valve
- Master Cylinder
- Backing Plates

High quality components, professional packaging, & after-sale support by "hands-on" technicians create an unbeatable value. Consider one of our complete brake line packages for a carefree installation.



Packages include At-the-Wheel Disc Conversion Kit & Master Cylinder with Valve (Manual) or Master Cylinder with Booster and Valve (Power).

POWER PACKAGE

MANUAL PACKAGE

STOCK HEIGHT FRONT KITS

MDC66WK.... 60-76At-the-Wheel Disc Conversion Kit
MDC66SD 60-76Manual Disc Conversion Package
MDC66DC..... 65-768" Dual Power Disc Conversion Package

252

FRONT DISC BRAKE CONVERSION UPGRADES

SHOW'N GO UPGRADE TRIM KITS

At-the-Wheel Disc Conversion Kits include upgraded drilled slotted rotors with zinc plating, powder coated calipers in red or black, & braided stainless hoses.



STOCK HEIGHT SHOW'N GO

MDC66WKS.... 60-76.... At-the-Wheel Disc Conversion Kit - Black
MDC66WKZ.... 60-76.... At-the-Wheel Disc Conversion Kit - Red
MDC66SDS 60-76.... Manual Disc Conversion Kit - Black
MDC66SDZ 60-76.... Manual Disc Conversion Kit - Red
MDC66DCS..... 60-76.... Power Disc Conversion Kit - Black
MDC66DCZ..... 60-76.... Power Disc Conversion Kit - Red

SHOW STOPPER TRIM PACKAGES

Includes At-the-Wheel Front Disc Conversion Kit with natural finish calipers. The Manual Packages get an upgraded chrome plated master cylinder and combination valve with bracket. Power Packages include an upgraded 8" dual chrome booster.



STOCK HEIGHT SHOW STOPPER

MDC66SDX 60-76.... Manual Disc Conversion Package
MDC66DCX..... 65-76.... 8" Dual Power Disc Conversion Package

BEST OF SHOW TRIM PACKAGES

Includes At-the-Wheel Front Disc Conversion Kit with black or red calipers. The Manual Packages get an upgraded chrome plated master cylinder and combination valve with bracket. Power Packages include an upgraded 8" dual chrome booster.



STOCK HEIGHT BEST OF SHOW

MDC66SDSX ... 60-76... Manual Disc Conversion Package - Black
MDC66SDZSX ... 60-76... Manual Disc Conversion Package - Red
MDC66DCSX... 65-76... 8" Dual Power Disc Conv Package - Black
MDC66DCZX... 65-76... 8" Dual Power Disc Conv Package - Red

MOPAR A-BODY 4-WHEEL DISC CONVERSIONS

**STREET
SERIES**

FOUR WHEEL DISC BRAKE CONVERSION KITS

 U.S.A. Made **TIMKEN** Bearings

FRONT CONVERSIONS INCLUDE:

- 11" Rotors (5 X 4.5")
- Forged Spindles
- Timken Bearings
- New Calipers
- Caliper Brackets
- Organic Pads
- Backing Plates
- Flex Hoses & Hardware
- Banjo Bolts & Copper Washers
- Dust Caps
- Castle Nuts & Pins
- Washers
- Grease Seals
- Steering Arm Bolts
- Master Cylinder
- 8" Dual Booster
- Adjustable Valve
- Pedal Rod Extension

REAR CONVERSIONS INCLUDE:

- 11.25" Rotors
- Caliper Brackets & Spacers
- Weld-On Hose Brackets
- New Loaded Caliper
- E-Brake Cables
- Flex Hoses

High quality components, & after the sale support by "hands-on" technicians. Complete brake line packages are available for a care free installation. Verify axle flange measurements for these kits.



GREEN BEARINGS REQUIRED

Packages include At-the-Wheel Disc Conversion Kit & Master Cylinder with Valve (Manual) or Master Cylinder with Booster and Valve (Power).

POWER PACKAGE

MANUAL PACKAGE

WORKS WITH 15" AND LARGER WHEELS WITH 5 X 4.5" BOLT PATTERN

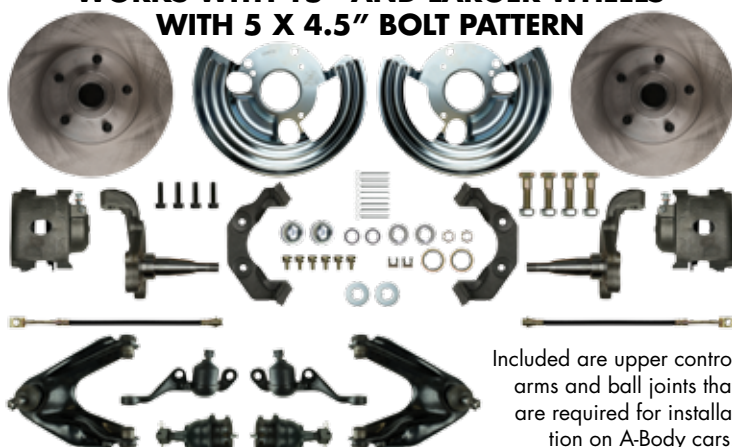

Included are upper control arms and ball joints that are required for installation on A-Body cars.

AT-THE-WHEEL FRONT KIT

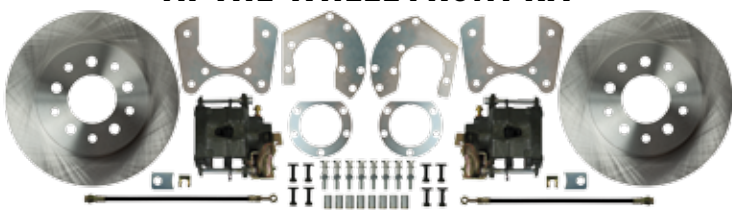

AT-THE-WHEEL REAR KIT

STOCK HEIGHT 4-WHEEL KITS

- MDC46SD ... 60-76... Manual Disc Conversion Package
- MDC46DC... 65-76... 8" Dual Power Disc Conversion Package
- WBK04 60-76... Green Bearing Set (2-Piece)

4-WHEEL DISC BRAKE CONVERSION UPGRADES

BEST OF SHOW TRIM PACKAGES



Includes At-the-Wheel Front Disc Conversion Kit with black or red calipers. Manual Packages get an upgraded chrome plated master cylinder & combination valve with bracket. Power Packages include an upgraded 8" dual chrome booster.

STOCK HEIGHT BEST OF SHOW

- MDC46SDSX ... 60-76 ... Manual Disc Conversion Package - Blk
- MDC46SDZX ... 60-76 ... Manual Disc Conversion Package - Red
- MDC46DCSX... 65-76 ... 8" Dual Power Disc Conv Package - Blk
- MDC46DCZX... 65-76 ... 8" Dual Power Disc Conv Package - Red

SHOW'N GO UPGRADE TRIM KITS

These At-the-Wheel Disc Conversion Kits (stock height or 2" drop) include upgraded drilled slotted rotors with zinc plating, powder coated calipers in red or black, and braided stainless hoses.

SHOW STOPPER TRIM PACKAGES



Includes At-the-Wheel Front Disc Conversion Kit with natural finish calipers. The Manual Packages get an upgraded chrome plated master cylinder and combination valve with bracket. Power Packages include an upgraded 8" dual chrome booster.

STOCK HEIGHT SHOW STOPPER

- MDC46SDX ... 60-76 ... Manual Disc Conversion Package
- MDC46DCX... 60-76 ... 8" Dual Power Disc Conversion Package

STOCK HEIGHT SHOW'N GO

- MDC46SDS ... 60-76 ... Manual Disc Conversion Pkg - Black
- MDC46SDZ ... 60-76 ... Manual Disc Conversion Pkg - Red
- MDC46DCS... 60-76 ... Power Disc Conversion Pkg - Black
- MDC46DCZ... 60-76 ... Power Disc Conversion Pkg - Red

MOPAR A-BODY REAR DISC CONVERSIONS

**STREET
SERIES**

REAR DISC BRAKE CONVERSION KITS

REAR CONVERSIONS INCLUDE:

- 11.25" Rotors (5 x 4.5")
- New Loaded Calipers
- Brackets & Spacers
- Weld-On Hose Brackets
- Flex Hoses
- Hardware
- E-Brake Cables

NOTE:

FITS FACTORY
REAR ENDS
CALL FOR CUSTOM
APPLICATIONS

Right Stuff disc conversions are the most complete kits in the industry at the right price. High quality components, professional packaging, and after-sale support by "hands-on" technicians create an unbeatable value. Consider one of our complete brake line packages for a carefree installation. See page 249 to verify axle flange measurements for these kits.

WORKS WITH 15" AND LARGER WHEELS WITH 5 X 4.5" BOLT PATTERN

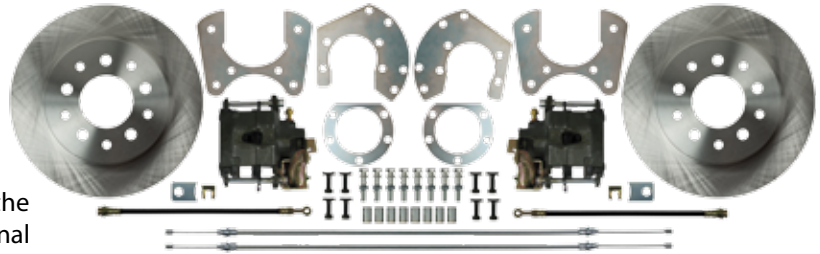

6 5/16" INSIDE ROTOR DIAMETER - 2.85" CENTER HOLE

GREEN BEARINGS REQUIRED

Green bearings allow our caliper brackets to bolt securely to the axle flange. We offer the bearings in a set as part# WBK04. Not recommended for extreme road course applications.

ATTENTION Before you order, be sure to measure the axle flange on your vehicle.

KITS WITH NON-E-BRAKE CALIPERS

- MDCRD1 ...62-72... Rear Disc Conversion (Use OE Cables)
- WBK0460-76... Green Bearing Set, 2-Piece (Use OE Cables)

KITS WITH E-BRAKE CALIPERS

- MDCRDM1 .. 60-76... 8-3/4", 9-3/4", Dana 60 (Non-E-Brake Caliper)
- WBK04..... 60-76... Green Bearing Set, 2-Pc (Non-E-Brake Caliper)

KITS WITH E-BRAKE - REAR CABLE

- MDCRA03 ...67-71... Rear Disc 108" WB without Intermediate
- MDCRA04 ...72-73... Rear Disc 108" WB with Intermediate
- MDCRA13 ...67-71... Rear Disc 111" WB without Intermediate
- MDCRA14 ...72-73... Rear Disc 111" WB with Intermediate
- WBK0460-76... Green Bearing Set, 2-Piece

REAR DISC BRAKE CONVERSION UPGRADES

**STREET
SERIES**

SHOW'N GO UPGRADE TRIM PACKAGES

These At-the-Wheel Rear Disc Conversion Kits (stock height or 2" drop) include upgraded drilled slotted rotors with zinc plating, powder coated calipers in red or black, and braided stainless hoses.



KITS WITH NON-E-BRAKE CALIPERS

- MDCRD1S ... 62-72 ... Rear Disc Conversion - Black (Use OE Cables)
- MDCRD1Z ... 62-72 ... Rear Disc Conversion - Red (Use OE Cables)
- WBK04 60-76 ... Green Bearing Set, 2-Piece

KITS WITH E-BRAKE CALIPERS

- MDCRDM1S 60-768-3/4", 9-3/4", Dana 60 - Black
- MDCRDM1Z 60-768-3/4", 9-3/4", Dana 60 - Red
- WBK04 60-76Green Bearing Set, 2-Piece

KITS WITH E-BRAKE - REAR CABLE

- MDCRA03S....67-71Rear Disc 108" WB without Intermediate - Blk
- MDCRA03Z....67-71Rear Disc 108" WB without Intermediate - Red
- MDCRA04S....72-73Rear Disc 108" WB with Intermediate - Blk
- MDCRA04Z....72-73Rear Disc 108" WB with Intermediate - Red
- MDCRA13S....67-71Rear Disc 111" WB without Intermediate - Blk
- MDCRA13Z....67-71Rear Disc 111" WB without Intermediate - Red
- MDCRA14S....72-73Rear Disc 111" WB with Intermediate - Blk
- MDCRA14Z....72-73Rear Disc 111" WB with Intermediate - Red
- WBK04.....60-76Green Bearing Set, 2-Piece



No Brainer BRAKE LINE KITS FOR DISC CONVERSIONS

SIMPLIFY YOUR DISC BRAKE CONVERSION INSTALLATION WITH ALL OF THE BRAKE LINES YOU WILL NEED.

When you add disc brakes to your car you are using a new valve that has different size ports pointing in different directions. Even if your lines are brand new or great originals, you are going to have issues trying to use them. Our No Brainer Brake Line Kit fixes all these issues from your master cylinder all the way back to your rear wheel cylinders or rear calipers. We give you all the lines to complete the installation. We also include the rear flex hose and a full clip set to install your lines. Extremely discounted prices and great instructions make this kit a No Brainer.

LINES ONLY FIT DART & DART SWINGER ONLY CARS WITH 111" WHEELBASE

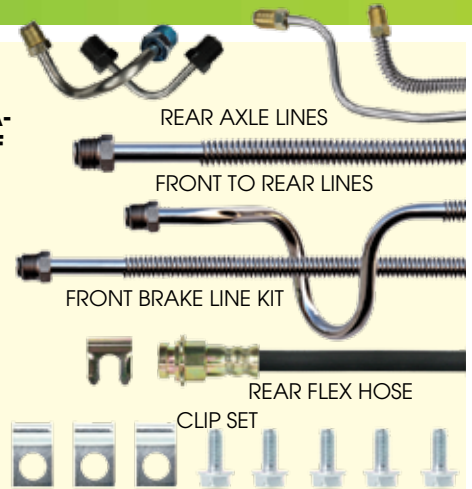

MANUAL - NO VACUUM BOOSTER FRONT DISC/REAR DRUM LINES

AM62U2	62	Manual - OE Steel
AM62U2S	62	Manual - Stainless
AM63U2	63	Manual - OE Steel
AM63U2S	63	Manual - Stainless
AM64U2	64-65	..	Manual - OE Steel
AM64U2S	64-65	..	Manual - Stainless
AM66U2	66	Manual - OE Steel
AM66U2S	66	Manual - Stainless
AM67U2	67	108" Wheelbase, 8-3/4" Rear End - OE Steel
AM67U2S	67	108" Wheelbase, 8-3/4" Rear End - Stainless
AM67U7	67	108" Wheelbase, 7-1/4" Rear End - OE Steel
AM67U7S	67	108" Wheelbase, 7-1/4" Rear End - Stainless
AM68U2	68-69	..	108" Wheelbase, 8-3/4" Rear End - OE Steel
AM68U2S	68-69	..	108" Wheelbase, 8-3/4" Rear End - Stainless
AM68U7	68-69	..	108" Wheelbase, 7-1/4" Rear End - OE Steel
AM68U7S	68-69	..	108" Wheelbase, 7-1/4" Rear End - Stainless
AM70U2	70	108" Wheelbase, 8-3/4" Rear End - OE Steel
AM70U2S	70	108" Wheelbase, 8-3/4" Rear End - Stainless
AM70U7	70	108" Wheelbase, 7-1/4" Rear End - OE Steel
AM70U7S	70	108" Wheelbase, 7-1/4" Rear End - Stainless
AM71U2	71	108" Wheelbase, 8-3/4" Rear End - OE Steel
AM71U2S	71	108" Wheelbase, 8-3/4" Rear End - Stainless
AM71U7	71	108" Wheelbase, 7-1/4" Rear End - OE Steel
AM71U7S	71	108" Wheelbase, 7-1/4" Rear End - Stainless
AM72U2	72	108" Wheelbase, 8-3/4" Rear End - OE Steel
AM72U2S	72	108" Wheelbase, 8-3/4" Rear End - Stainless
AM72U7	72	108" Wheelbase, 7-1/4" Rear End - OE Steel
AM72U7S	72	108" Wheelbase, 7-1/4" Rear End - Stainless
AM67O2	67	111" Wheelbase, 8-3/4" Rear End - OE Steel
AM67O2S	67	111" Wheelbase, 8-3/4" Rear End - Stainless
AM67O7	67	111" Wheelbase, 7-1/4" Rear End - OE Steel
AM67O7S	67	111" Wheelbase, 7-1/4" Rear End - Stainless
AM68O2	68-69	..	111" Wheelbase, 8-3/4" Rear End - OE Steel
AM68O2S	68-69	..	111" Wheelbase, 8-3/4" Rear End - Stainless
AM68O7	68-69	..	111" Wheelbase, 7-1/4" Rear End - OE Steel
AM68O7S	68-69	..	111" Wheelbase, 7-1/4" Rear End - Stainless
AM70O2	70	111" Wheelbase, 8-3/4" Rear End - OE Steel
AM70O2S	70	111" Wheelbase, 8-3/4" Rear End - Stainless
AM70O7	70	111" Wheelbase, 7-1/4" Rear End - OE Steel
AM70O7S	70	111" Wheelbase, 7-1/4" Rear End - Stainless
AM71O2	71	111" Wheelbase, 8-3/4" Rear End - OE Steel
AM71O2S	71	111" Wheelbase, 8-3/4" Rear End - Stainless
AM71O7	71	111" Wheelbase, 7-1/4" Rear End - OE Steel
AM71O7S	71	111" Wheelbase, 7-1/4" Rear End - Stainless
AM72O2	72	111" Wheelbase, 8-3/4" Rear End - OE Steel
AM72O2S	72	111" Wheelbase, 8-3/4" Rear End - Stainless
AM72O7	72	111" Wheelbase, 7-1/4" Rear End - OE Steel
AM72O7S	72	111" Wheelbase, 7-1/4" Rear End - Stainless

POWER - WITH VACUUM BOOSTER FRONT DISC/REAR DRUM LINES

AP62U2	62	Power - OE Steel
AP62U2S	62	Power - Stainless
AP63U2	63	Power - OE Steel
AP63U2S	63	Power - Stainless
AP64U2	64-65	..	Power - OE Steel
AP64U2S	64-65	..	Power - Stainless
AP66U2	66	Power - OE Steel
AP66U2S	66	Power - Stainless
AP67U2	67	108" Wheelbase, 8-3/4" Rear End - OE Steel
AP67U2S	67	108" Wheelbase, 8-3/4" Rear End - Stainless
AP67U7	67	108" Wheelbase, 7-1/4" Rear End - OE Steel
AP67U7S	67	108" Wheelbase, 7-1/4" Rear End - Stainless
AP68U2	68-69	..	108" Wheelbase, 8-3/4" Rear End - OE Steel
AP68U2S	68-69	..	108" Wheelbase, 8-3/4" Rear End - Stainless
AP68U7	68-69	..	108" Wheelbase, 7-1/4" Rear End - OE Steel
AP68U7S	68-69	..	108" Wheelbase, 7-1/4" Rear End - Stainless
AP70U2	70	108" Wheelbase, 8-3/4" Rear End - OE Steel
AP70U2S	70	108" Wheelbase, 8-3/4" Rear End - Stainless
AP70U7	70	108" Wheelbase, 7-1/4" Rear End - OE Steel
AP70U7S	70	108" Wheelbase, 7-1/4" Rear End - Stainless
AP71U2	71	108" Wheelbase, 8-3/4" Rear End - OE Steel
AP71U2S	71	108" Wheelbase, 8-3/4" Rear End - Stainless
AP71U7	71	108" Wheelbase, 7-1/4" Rear End - OE Steel
AP71U7S	71	108" Wheelbase, 7-1/4" Rear End - Stainless
AP72U2	72	108" Wheelbase, 8-3/4" Rear End - OE Steel
AP72U2S	72	108" Wheelbase, 8-3/4" Rear End - Stainless
AP72U7	72	108" Wheelbase, 7-1/4" Rear End - OE Steel
AP72U7S	72	108" Wheelbase, 7-1/4" Rear End - Stainless
AP67O2	67	111" Wheelbase, 8-3/4" Rear End - OE Steel
AP67O2S	67	111" Wheelbase, 8-3/4" Rear End - Stainless
AP67O7	67	111" Wheelbase, 7-1/4" Rear End - OE Steel
AP67O7S	67	111" Wheelbase, 7-1/4" Rear End - Stainless
AP68O2	68-69	..	111" Wheelbase, 8-3/4" Rear End - OE Steel
AP68O2S	68-69	..	111" Wheelbase, 8-3/4" Rear End - Stainless
AP68O7	68-69	..	111" Wheelbase, 7-1/4" Rear End - OE Steel
AP68O7S	68-69	..	111" Wheelbase, 7-1/4" Rear End - Stainless
AP70O2	70	111" Wheelbase, 8-3/4" Rear End - OE Steel
AP70O2S	70	111" Wheelbase, 8-3/4" Rear End - Stainless
AP70O7	70	111" Wheelbase, 7-1/4" Rear End - OE Steel
AP70O7S	70	111" Wheelbase, 7-1/4" Rear End - Stainless
AP71O2	71	111" Wheelbase, 8-3/4" Rear End - OE Steel
AP71O2S	71	111" Wheelbase, 8-3/4" Rear End - Stainless
AP71O7	71	111" Wheelbase, 7-1/4" Rear End - OE Steel
AP71O7S	71	111" Wheelbase, 7-1/4" Rear End - Stainless
AP72O2	72	111" Wheelbase, 8-3/4" Rear End - OE Steel
AP72O2S	72	111" Wheelbase, 8-3/4" Rear End - Stainless
AP72O7	72	111" Wheelbase, 7-1/4" Rear End - OE Steel
AP72O7S	72	111" Wheelbase, 7-1/4" Rear End - Stainless



No Brainer BRAKE LINE KITS FOR DISC CONVERSIONS

SIMPLIFY YOUR DISC BRAKE CONVERSION INSTALLATION WITH ALL OF THE BRAKE LINES YOU WILL NEED.

When you add disc brakes to your car you are using a new valve that has different size ports pointing in different directions. Even if your lines are brand new or great originals, you are going to have issues trying to use them. Our No Brainer Brake Line Kit fixes all these issues from your master cylinder all the way back to your rear wheel cylinders or rear calipers. We give you all the lines to complete the installation. We also include the rear flex hose and a full clip set to install your lines. Extremely discounted prices and great instructions make this kit a No Brainer.

LINES ONLY FIT DART & DART SWINGER ONLY CARS WITH 111" WHEELBASE

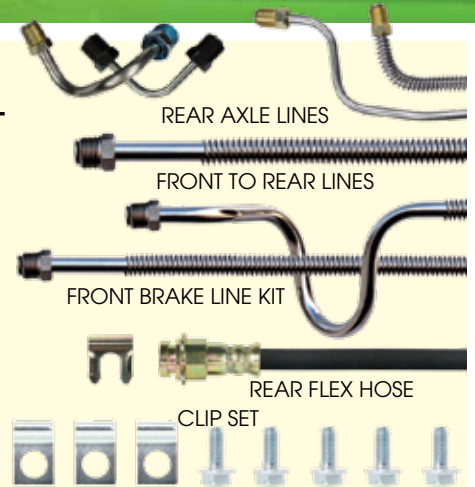

MANUAL - NO VACUUM BOOSTER 4-WHEEL DISC MANUAL LINES

AM62U4 62 Manual - OE Steel
AM62U4S 62 Manual - Stainless
AM63U4 63 Manual - OE Steel
AM63U4S 63 Manual - Stainless
AM64U4 64-65 Manual - OE Steel
AM64U4S 64-65 Manual - Stainless
AM66U4 66 Manual - OE Steel
AM66U4S 66 Manual - Stainless
AM67U4 67 108" Wheelbase, 8-3/4" Rear End - OE Steel
AM67U4S 67 108" Wheelbase, 8-3/4" Rear End - Stainless
AM67U8 67 108" Wheelbase, 7-1/4" Rear End - OE Steel
AM67U8S 67 108" Wheelbase, 7-1/4" Rear End - Stainless
AM68U4 68-69 108" Wheelbase, 8-3/4" Rear End - OE Steel
AM68U4S 68-69 108" Wheelbase, 8-3/4" Rear End - Stainless
AM68U8 68-69 108" Wheelbase, 7-1/4" Rear End - OE Steel
AM68U8S 68-69 108" Wheelbase, 7-1/4" Rear End - Stainless
AM70U4 70 108" Wheelbase, 8-3/4" Rear End - OE Steel
AM70U4S 70 108" Wheelbase, 8-3/4" Rear End - Stainless
AM70U8 70 108" Wheelbase, 7-1/4" Rear End - OE Steel
AM70U8S 70 108" Wheelbase, 7-1/4" Rear End - Stainless
AM71U4 71 108" Wheelbase, 8-3/4" Rear End - OE Steel
AM71U4S 71 108" Wheelbase, 8-3/4" Rear End - Stainless
AM71U8 71 108" Wheelbase, 7-1/4" Rear End - OE Steel
AM71U8S 71 108" Wheelbase, 7-1/4" Rear End - Stainless
AM72U4 72 108" Wheelbase, 8-3/4" Rear End - OE Steel
AM72U4S 72 108" Wheelbase, 8-3/4" Rear End - Stainless
AM72U8 72 108" Wheelbase, 7-1/4" Rear End - OE Steel
AM72U8S 72 108" Wheelbase, 7-1/4" Rear End - Stainless
AM67O4 67 111" Wheelbase, 8-3/4" Rear End - OE Steel
AM67O4S 67 111" Wheelbase, 8-3/4" Rear End - Stainless
AM67O8 67 111" Wheelbase, 7-1/4" Rear End - OE Steel
AM67O8S 67 111" Wheelbase, 7-1/4" Rear End - Stainless
AM68O4 68-69 111" Wheelbase, 8-3/4" Rear End - OE Steel
AM68O4S 68-69 111" Wheelbase, 8-3/4" Rear End - Stainless
AM68O8 68-69 111" Wheelbase, 7-1/4" Rear End - OE Steel
AM68O8S 68-69 111" Wheelbase, 7-1/4" Rear End - Stainless
AM70O4 70 111" Wheelbase, 8-3/4" Rear End - OE Steel
AM70O4S 70 111" Wheelbase, 8-3/4" Rear End - Stainless
AM70O8 70 111" Wheelbase, 7-1/4" Rear End - OE Steel
AM70O8S 70 111" Wheelbase, 7-1/4" Rear End - Stainless
AM71O4 71 111" Wheelbase, 8-3/4" Rear End - OE Steel
AM71O4S 71 111" Wheelbase, 8-3/4" Rear End - Stainless
AM71O8 71 111" Wheelbase, 7-1/4" Rear End - OE Steel
AM71O8S 71 111" Wheelbase, 7-1/4" Rear End - Stainless
AM72O4 72 111" Wheelbase, 8-3/4" Rear End - OE Steel
AM72O4S 72 111" Wheelbase, 8-3/4" Rear End - Stainless
AM72O8 72 111" Wheelbase, 7-1/4" Rear End - OE Steel
AM72O8S 72 111" Wheelbase, 7-1/4" Rear End - Stainless

POWER - WITH VACUUM BOOSTER 4-WHEEL DISC POWER LINES

AP62U4 62 Power - OE Steel
AP62U4S 62 Power - Stainless
AP63U4 63 Power - OE Steel
AP63U4S 63 Power - Stainless
AP64U4 64-65 Power - OE Steel
AP64U4S 64-65 Power - Stainless
AP66U4 66 Power - OE Steel
AP66U4S 66 Power - Stainless
AP67U4 67 108" Wheelbase, 8-3/4" Rear End - OE Steel
AP67U4S 67 108" Wheelbase, 8-3/4" Rear End - Stainless
AP67U8 67 108" Wheelbase, 7-1/4" Rear End - OE Steel
AP67U8S 67 108" Wheelbase, 7-1/4" Rear End - Stainless
AP68U4 68-69 108" Wheelbase, 8-3/4" Rear End - OE Steel
AP68U4S 68-69 108" Wheelbase, 8-3/4" Rear End - Stainless
AP68U8 68-69 108" Wheelbase, 7-1/4" Rear End - OE Steel
AP68U8S 68-69 108" Wheelbase, 7-1/4" Rear End - Stainless
AP70U4 70 108" Wheelbase, 8-3/4" Rear End - OE Steel
AP70U4S 70 108" Wheelbase, 8-3/4" Rear End - Stainless
AP70U8 70 108" Wheelbase, 7-1/4" Rear End - OE Steel
AP70U8S 70 108" Wheelbase, 7-1/4" Rear End - Stainless
AP71U4 71 108" Wheelbase, 8-3/4" Rear End - OE Steel
AP71U4S 71 108" Wheelbase, 8-3/4" Rear End - Stainless
AP71U8 71 108" Wheelbase, 7-1/4" Rear End - OE Steel
AP71U8S 71 108" Wheelbase, 7-1/4" Rear End - Stainless
AP72U4 72 108" Wheelbase, 8-3/4" Rear End - OE Steel
AP72U4S 72 108" Wheelbase, 8-3/4" Rear End - Stainless
AP72U8 72 108" Wheelbase, 7-1/4" Rear End - OE Steel
AP72U8S 72 108" Wheelbase, 7-1/4" Rear End - Stainless
AP67O4 67 111" Wheelbase, 8-3/4" Rear End - OE Steel
AP67O4S 67 111" Wheelbase, 8-3/4" Rear End - Stainless
AP67O8 67 111" Wheelbase, 7-1/4" Rear End - OE Steel
AP67O8S 67 111" Wheelbase, 7-1/4" Rear End - Stainless
AP68O4 68-69 111" Wheelbase, 8-3/4" Rear End - OE Steel
AP68O4S 68-69 111" Wheelbase, 8-3/4" Rear End - Stainless
AP68O8 68-69 111" Wheelbase, 7-1/4" Rear End - OE Steel
AP68O8S 68-69 111" Wheelbase, 7-1/4" Rear End - Stainless
AP70O4 70 111" Wheelbase, 8-3/4" Rear End - OE Steel
AP70O4S 70 111" Wheelbase, 8-3/4" Rear End - Stainless
AP70O8 70 111" Wheelbase, 7-1/4" Rear End - OE Steel
AP70O8S 70 111" Wheelbase, 7-1/4" Rear End - Stainless
AP71O4 71 111" Wheelbase, 8-3/4" Rear End - OE Steel
AP71O4S 71 111" Wheelbase, 8-3/4" Rear End - Stainless
AP71O8 71 111" Wheelbase, 7-1/4" Rear End - OE Steel
AP71O8S 71 111" Wheelbase, 7-1/4" Rear End - Stainless
AP72O4 72 111" Wheelbase, 8-3/4" Rear End - OE Steel
AP72O4S 72 111" Wheelbase, 8-3/4" Rear End - Stainless
AP72O8 72 111" Wheelbase, 7-1/4" Rear End - OE Steel
AP72O8S 72 111" Wheelbase, 7-1/4" Rear End - Stainless

FRONT BRAKE LINE KITS

Front brake line kits consist of all brake lines under the hood. This includes the master cylinder to the distribution, combination or metering valve. The left and right front lines that run to the front flex hoses are also included. Call for individual component pricing. These line kits are for vehicles with factory brake systems.

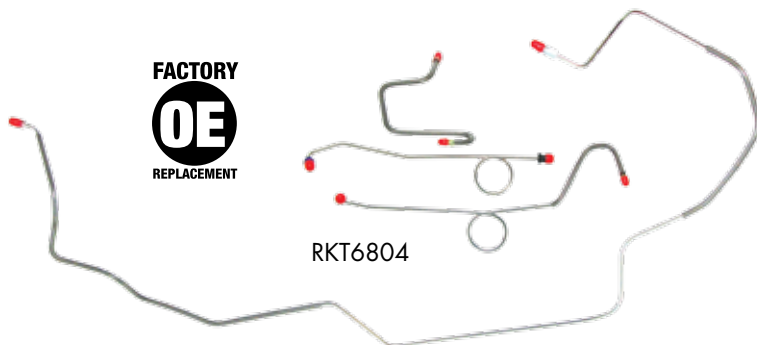

ADD "S" TO PART NUMBER FOR STAINLESS STEEL

RKT6003 60.....	Power Drum	3 Pcs.
RKT6201	... 62-64 ...	Max Wedge.....	3 Pcs.
RKT6401	... 62-64 ...	Except Max Wedge.....	3 Pcs.
RKT6501 65.....	Standard Brakes	3 Pcs.
RKT6502 65.....	Power Brakes	3 Pcs.
RKT6601 66.....	Standard Brakes, Right Line Has 4" Rise Above Bellhousing	3 Pcs.
RKT6603 66.....	Std Brakes, Right Line is Straight Above Bellhousing	3 Pcs.
RKT6602 66.....	Power Brakes, Right Line Has 4" Rise Above Bellhousing	3 Pcs.
RKT6604 66.....	Power Brakes, Right Line is Straight Above Bellhousing.....	3 Pcs.
RKT6605 66.....	Hemi, Power Brakes, Right Line Has 4" Rise Above Bellhousing. 3 Pcs.	
RKT6606 66.....	Hemi, Power, Right Line is Straight Above Bellhousing	3 Pcs.
RKT6701 67.....	Std Brakes, Right Line Has 4" Rise Over Bellhousing Area & is Clipped Under Column	4 Pcs.
RKT6702 67.....	Std Brakes, Right Line is Straight Above Bellhousing	4 Pcs. 61.95 ... 82.95
RKT6703 67.....	Standard Brakes, Right Line Clips To Left Side Fender, Not Under The Column	4 Pcs.
RKT6704 67.....	Power Brakes, Right Line Has 4" Rise Above Bellhousing & is Clipped Under Column.....	4 Pcs.
RKT6705 67.....	Power Brakes, Right Line is Straight Above Bellhousing	4 Pcs.
RKT6706 67.....	Power Brakes, Right Line Clips to Left Side Fender	4 Pcs.
RKT6706	... 68-69 ...	Hemi Cars, Right Line Over Frame Thru Splash-Guard	4 Pcs.
RKT6801	... 68-70 ...	Std. Or Power Drum, Right Front Runs Under Frame.....	4 Pcs.
RKT6804	... 68-70 ...	Std. or Power Drum, Right, Front Runs Over Frame	4 Pcs.
RKT6808	... 69-70 ...	Disc, Right Master Cylinder Ports, No Metering Valve	4 Pcs.
RKT6803	... 68-70 ...	Disc, Right Master Cylinder Ports, Uses 2 Pc. Front-Rear Line & Metering Valve	5 Pcs.
RKT6806	... 68-69 ...	Disc, Left Master Cyl. Ports, Uses 2 Pc. Front-Rear Line & No Metering Valve	4 Pcs.

RKT6805	... 68-70 ...	Disc, Left Master Cyl. Ports, Uses 2 Pc Front-Rear Line & Metering Valve, Under Frame ...	5 Pcs.
RKT6807	... 68-70 ...	Hemi, Power. Drum, Right Line Passes Under Frame	4 Pcs.
RKT6802	... 68-70 ...	Hemi, Disc Brakes, with 2 Pc Front-Rear Line & Metering Valve, Runs Under Frame	5 Pcs.
RKT7101 71.....	Standard Drum	4 Pcs.
RKT7102 71.....	Power Drum	4 Pcs.
RKT7103 71.....	Power Disc Brakes.....	5 Pcs.
RKT7104 71.....	Power Disc Brakes, Hemi	5 Pcs.
RKT7201 72.....	Standard Drum Brakes	4 Pcs.
RKT7202 72.....	Power Drum Brakes	4 Pcs.
RKT7203 72.....	Power Disc Brakes.....	4 Pcs.
RKT7303 73.....	Power Disc	4 Pcs.
RKT7402 74.....	Power Disc	4 Pcs.
RKT7501 75.....	Dodge Charger, Power Disc	4 Pcs.
RKT7601	... 76-79 ...	Power Disc	4 Pcs.

REAR AXLE BRAKE LINES

Rear axle brake lines include a pair of lines that run across the rear axle housing. These lines connect the wheel cylinders or calipers to the flex hose in the middle of the rear end. These lines work with original housings that use factory brakes. Modifications such as rear disc brakes or narrowed rear ends will likely require special lines. Call for more information.

ADD "S" TO PART NUMBER FOR STAINLESS STEEL

RRA600160	All	2 Pcs.
RRA6401	.. 62-65 ...	All	2 Pcs.
RRA6601	.. 66-67 ...	Rear Axle Dana.....	2 Pcs.
RRA6801	.. 66-69 ...	Rear Axle, 8-3/4" Only	2 Pcs.
RRA6802	.. 68-69 ...	Dana Rear Axle.....	2 Pcs.
RRA700170	Rear Axle, 8-3/4" & Dana	2 Pcs.
RRA7101	.. 71-72 ...	8-3/4" Rear Axle	2 Pcs.
RRA7102	.. 71-72 ...	Dana Rear Axle.....	2 Pcs.
RRA730173	All	2 Pcs.
RRA740174	8-3/4" Rear Axle	2 Pcs.
RRA7601	.. 75-79 ...	All	2 Pcs.

MOPAR B-BODY BRAKE LINES & FLEX HOSES

FRONT TO REAR BRAKE LINES

Front to rear brake lines go from the distribution, combination or metering valve along the length of the vehicle to the rear flex hose. Lines are manufactured in 1 or 2 pieces based on factory specifications.



ADD "S" TO PART NUMBER FOR STAINLESS STEEL

- RIN600160 Dart
- RIN6201 62-64 Dodge
- RIN6401 62-65 Plymouth
- RIN630163 Dodge Wagon
- RIN640165 Dodge
- RIN660166 Drum Brakes
- RIN660266 Disc Brakes..... 3 Pcs.
- RIN6801 67-70 Disc Only * 2 Pcs.
- RIN6802 67-70 Drum or Disc, without Separate Proportioning Valve
- RIN710171 Drum or Disc
- RIN710172 Drum Only
- RIN720272 Disc Only
- RIN7301 73-74 Disc Only
- RIN7601 75-79 Power Disc

*USES RMB6801 PROPORTIONING VALVE

DISC CALIPER LINES

Front disc caliper lines connect the front flex hoses to the calipers. They were typically used on 4 piston calipers in the late 1960's. Please verify fitting sizes before ordering as rebuilt calipers may not match the originals.



- RFB680568-70.....Bendix 4-Piston Front Caliper Line Set 2-Pc
- RFB6805S.....68-70.....Bendix 4-Piston Front Caliper Line Set 2-Pc

HOSE BLOCKS

Breather bolts vent the rear end and hold the distribution block to the housing. Some cars have a block crimped directly to the hose. Others use the screw on blocks listed here. Verify the specifics of your application before ordering.

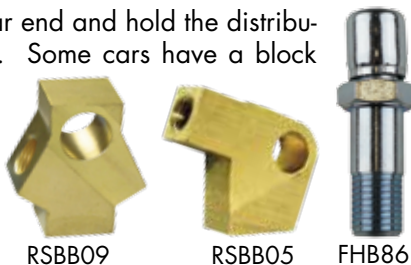

- FHB86 62-76Breather Bolt
- RSBB09 67-69 "Y" Block on Rear Axle, Dana
- RSBB49 66-69 "Y" Block on Rear Axle, 8 3/4"
- RSBB09 70 "Y" Block on Rear Axle, All
- RSBB05 71-74 "L" Block on Rear Axle

FRONT BRAKE FLEX HOSES

Front flex hoses provide a flexible connection from the body or frame to the front calipers or wheel cylinders as they move during suspension travel. Choose between O.E. rubber or braided stainless steel. All of our hoses are D.O.T. approved. Hoses are priced individually.

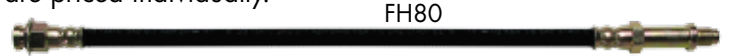

ADD "S" TO PART NUMBER FOR STAINLESS STEEL

- FH80 62-69Drum
- FH93 66-69Disc
- FH81 70-72Drum
- FH84 70-72Disc
- FH211 73-76Front Disc Flex Hose

REAR BRAKE FLEX HOSES

Rear flex hoses carry brake fluid between the body of the car and the rear. Hoses are available in O.E. rubber and braided stainless steel. 'T' blocks are attached whenever factory correct. All of our hoses are D.O.T. approved. Prices are per hose.



ADD "S" TO PART NUMBER FOR STAINLESS STEEL

- FH110 62-65All Cars
- FH82 66-698 3/4"
- FH83 66-69Dana
- FH85 70-71All Cars
- FH86 72-77All Cars

WHEEL CYLINDERS

Wheel cylinders are priced individually. Hardware not included.



- WC77 60-62 Left Front, Lower
- WC79 63-69 Left Front
- WC80 63-69 Right Front
- WC73 65-69 Rear, 5/16"
- WC68 70-72 Left Front, with 10" Brakes
- WC69 70-72 Right Front, with 10" Brakes
- WC74 70-86 Rear, 15/16", with 10" Brakes
- WC81 75-76 Rear, 13/16", with 9" Brakes

E-BRAKE CABLES

Parking brake cable sets contain all the individual cables & hardware. Front, rear, & intermediate cables are also sold individually. While supplies last. Sold in O.E. mild steel & stainless steel. See rear disc brake cables if you have a rear disc conversion.



ADD "S" TO PART NUMBER FOR STAINLESS STEEL

• Front Brake Cables

- EBC7022.....63-65.....Dodge
- EBC7007.....66-70.....All Cars
- EBC7008.....71-72.....All Cars
- EBC7013.....73-74.....All Cars

• Rear Brake Cables

- EBC9025.....63-65.....Dodge
- EBC9008.....66-70.....Long
- EBC9009.....66-70.....Short
- EBC9010.....71-72.....All Cars
- EBC9013.....73-74.....All Cars

• Intermediate Brake Cables

- EBC8017.....63-65.....Dodge
- EBC8007.....71-72.....All Cars
- EBC8013.....73-74.....All Cars

• E-Brake Cable Kits

- RSBCR0163-65.....Dodge
- RSBCR0263-65.....Plymouth
- RSBCR0366-70.....All Cars
- RSBCR0471-72.....All Cars
- RSBCR0573-74.....All Cars

• E-Brake Hardware

- EBH3005..... 63-70 Silver Center Pull
- EBH3004..... 63-65 Center to Rear Silver Connector
- EBH1001..... 63-74 Jam Nut
- FHC01 66-72 Gold Cadmium Plated C Clip
- EBH2009..... 71-74 18.5" Hook
- EBH3005..... 71-72 Equalizer
- EBH3006..... 71-74 Center Pull
- EBH2012..... 71-74 J Hook
- EBH3004..... 73-74 Center to Rear Silver Connector

BRAKE CALIPERS

Rebuild calipers do not include pads or hardware. Cores are required due to lack of availability.



Cost Core

- BC1866-69..... Bendix 4 Piston Caliper, Left or Right, Cores Required!

BRAKE LINE CLIPS

Brake line clip sets contain all the clips needed to fasten the brake tubes to the frame or body of the car. Individual clips and fasteners are available on pages 284-285.



- BCS002..... 62-70 Brake Line Clips
- BCS003..... 71-74 Brake Line Clips

BOOSTER/MASTER COMBOS

Buy your Booster & Master together at a discounted price. These brake boosters are a direct bolt on for manual brake cars. If you have factory power brakes, you will need to modify your firewall.



G800110



J800110

- G800110.....8" Dual Booster - 1-1/16" Bore Master, Gold
- J800110.....8" Dual Booster - 1-1/16" Bore Master, Chrome
- G800115.....8" Dual Booster - 15/16" Bore Master, Gold
- J800115.....8" Dual Booster - 15/16" Bore Master, Chrome

MOPAR B-BODY MASTER CYLINDERS & BOOSTERS

MASTER CYLINDERS

All master cylinders are completely new units with no core charge. A deep cylinder pocket with a removable plug provides compatibility with manual brakes as well as power-assisted applications.



DBMC10 62-76 1-1/16" Bore Diameter
 DBMC10C 62-76 1-1/16" Bore Diameter Chrome
 DBMC15 62-76 15/16" Bore Diameter
 DBMC15C 62-76 15/16" Bore Diameter Chrome

BRAKE BOOSTERS

The RPB8001 with high rise bracket is perfect for Hemi cars and vehicles being converted from manual to power brakes. RPB8066 and RPB8070 are great for cars with a factory booster bolted directly to the firewall.

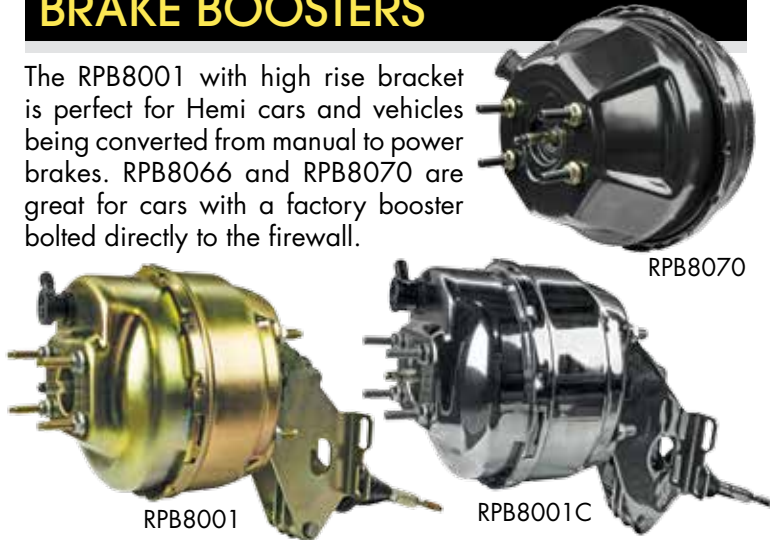

RPB8001 8" Dual Diaphragm with High Rise Bracket, Gold
 RPB8001C 8" Dual Diaphragm with High Rise Bracket, Chrome
 RPB8066 ... 66-70 Bendix Style with Factory Correct Bracket, Black
 RPB8070 ... 71-74 Bendix Style with Factory Correct Bracket, Black

VALVES & BLOCKS

We offer a full line of metering blocks, proportioning valves, distribution blocks & combination valves for factory drum & disc brake applications.

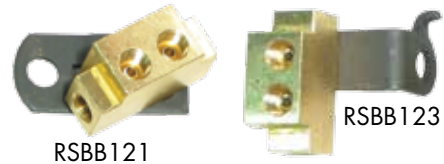

RSBB121 62-64 Dual Master Conversion Block
 RSBB123 65-66 Dual Master Conversion Block

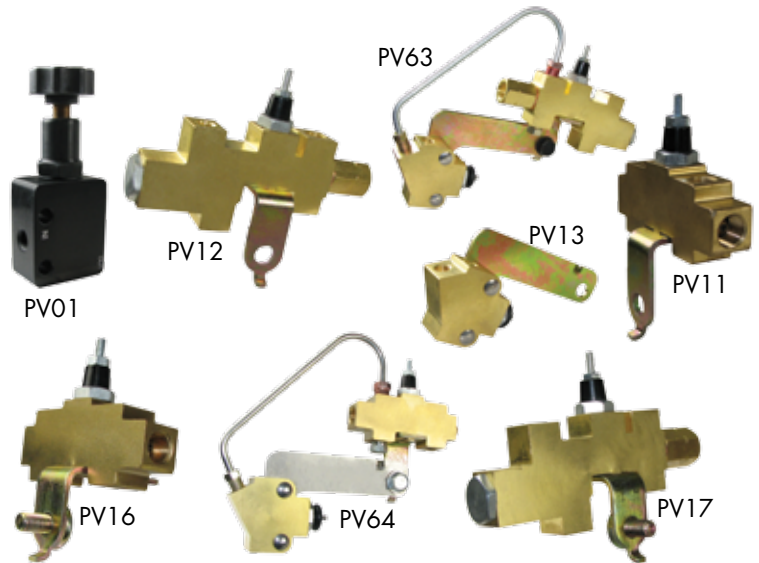

PV01 All Adjustable Proportioning Valve
 PV11 67-70 Drum Brake Distribution Block
 PV12 69-70 Disc Brake Combination Valve
 PV13 69-70 3 Port Metering Valve
 PV16 71-74 Drum Brake Distribution Block
 PV17 71 Disc Brake Combination Valve
 PV62 68-69 Disc Brake Valve Set 2 Pcs.
 PV63 69-70 Disc Brake Valve Set 2 Pcs.
 PV64 69-70 Disc Brake Valve Set 3 Pcs.

MAIN FUEL LINES

Main lines carry fuel from the tank in the rear of the car to the fuel pump or rail in the front. Call for 1/2" lines.

ADD "S" TO PART NUMBER FOR STAINLESS STEEL

RGL6002 60 Dart Series, 118" Wheel Base .. 2 Pcs.
 RGL6201 ... 62-63... 5/16" Main Line
 RGL6202 ... 62-63... 3/8" Main Line
 RGL6203 ... 62-65... 5/16" Wagon Fuel Line
 RGL6401 ... 64-65... 5/16" Main Fuel Line
 RGL6402 ... 64-65... 3/8" Main Fuel Line
 RGL6404 64 3/8" Main Fuel Line
 RGL6601 ... 66-67... 5/16" Main Fuel Line
 RGL6602 ... 66-67... 3/8" Main Fuel Line
 RGL6705 ... 66-67... 5/16" Wagon Fuel Line
 RGL6801 ... 68-69... 5/16" Main Fuel Line

RGL6802 ... 68-69... 3/8" Main Fuel Line
 RGL7001 70 5/16" Main Fuel Line
 RGL7002 70 3/8" Main Fuel Line
 RGL7101 71 5/16" Main Fuel Line
 RGL7102 71 3/8" Main Fuel Line
 RGL7201 72 5/16" Main Fuel Line
 RGL7202 72 3/8" Main Fuel Line
 RGL7303 73 3/8" Main Fuel Line
 RGL7301 73 5/16" Main Fuel Line
 RGL7403 74 3/8" Main Line
 RGL7501 75 3/8" Main Fuel Line, Charger
 RGL7601 ... 76-79... 5/16" Main Fuel Line

RETURN FUEL LINES

Return lines carry excess fuel from fuel pump or fuel filter back to the tank. Not all vehicles were equipped with a return line. They are typically made of 1/4" diameter tubing. Multiple piece sets are noted.

RGL7302
CLOSE UP VIEW

ADD "S" TO PART NUMBER FOR STAINLESS STEEL

- RGL680368-69.... 1/4" Return Line
- RGL700370 1/4" Return Line
- RGL710371 1/4" Return Line
- RGL720372 1/4" Return Line
- RGL730273 1/4" Return Line..... 2 Pcs.
- RGL740474 1/4" Return Line
- RGL750275 1/4" Return Line, Charger 2 Pcs.
- RGL760276-79.... 3/16" Return Line..... 2 Pcs.

VAPOR RETURN LINES

Emission control systems use these 5/16" lines to handle fuel vapors. Some vehicles use a single front to rear line. Others utilize a charcoal canister and require 3 or 4 additional small lines. Multiple piece sets are noted.

RGL7004
CLOSE UP VIEW

ADD "S" TO PART NUMBER FOR STAINLESS STEEL

- RGL700470 5/16" ECS Vapor Line
- RGL710471 5/16" Vapor Line..... 2 Pcs.
- RGL720472 5/16" Vapor Line..... 2 Pcs.
- RGL740574 5/16" Vapor Return Line

FUEL LINE CLIPS

Fuel line clips hold tubing to the frame or body of the car. Fasteners are included as noted. See page 284-285 for individual clips.



BCS010

- BCS002..... 62-70.....Brake Line Clips
- BCS011..... 66-70.....3/8" Fuel Line Clips
- BCS012..... 66-70.....5/16" Fuel Line Clips
- BCS010..... 68-70.....5/16" & 1/4 Fuel Line Clips
- BCS015..... 68-70.....3/8" & 1/4 Fuel Line Clips
- BCS013..... 70.....3/8", 5/16", & 1/4" Fuel Clips (CA Emissions)
- BCS014..... 70.....5/16" & 5/16" Fuel Line Clips (CA Emissions)
- BCS003..... 71-74.....Brake Line Clips
- BCS016..... 71-74.....5/16" & 5/16" Fuel Line Clips
- BCS017..... 71-74.....3/8" & 5/16" Fuel Line Clips
- BCS018..... 71-74.....3/8", 5/16" & 1/4" Fuel Line Clips
- BCS019..... 71-74.....3/8" & 1/4" Fuel Line Clips

FUEL PUMP TO CARB LINES

Fuel pump to carburetor lines connect the fuel pump to the carburetor. Brass blocks and fittings are included as noted. These lines are intended to work only with factory pump, motor, intake and carburetor combinations.

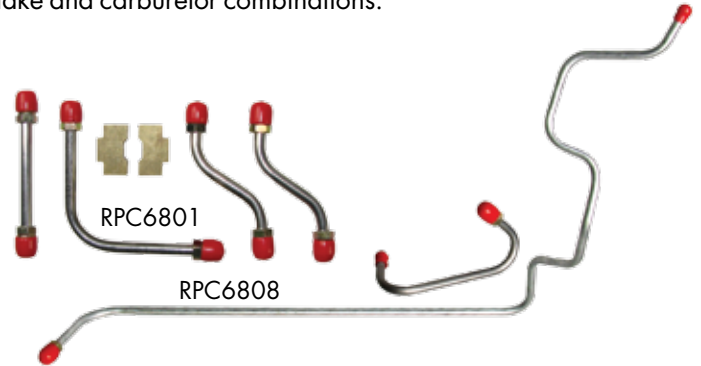

ADD "S" TO PART NUMBER FOR STAINLESS STEEL

- RPC6003 60 Dart 383, Dual 4's 3 Pcs.
- RPC6301 63 Max Wedge, with 3447 Carbs 5 Pcs.
- RPC6401 64 Max Wedge, 5 Lines & Fittings,
For Use with #3705 Carbs. Only
- RPC6406 64 Slant 6, 225 2 Pcs.
- RPC6402 ...64-65... Street Wedge 426, Single 4 BBL,
3611 S Carb, 5/16" Line
- RPC6601 ...66-67... 383/440 with AFB 4 V..... 2 Pcs.
- RPC6602 ...66-67... 426 Hemi, 5 Lines, & Tee
- RPC6702 67 Slant 6, 225 2 Pcs.
- RPC6701 ...67-72... 318 2 Pcs.
- RPC6810...68-69... 383/400 with AVS 2 Pcs.
- RPC6804...68-71... 426 Hemi with 4 Lines, 2 Carburetor
Fittings, Tee & Bracket
- RPC7001 ...68-71... 440 with AVS 4 BBL 2 Pcs.
- RPC6806...68-72... 340 with Carter AVS 2 Pcs.
- RPC6808 ...68-72... 400, 440 with Carter T-Quad .. 2 Pcs.
- RPC6809 ...68-72... 383, 440 with Single Inlet Holley
- RPC6803 ...69-70... 440 6 Pack, Lower Set, with 2 Lines
- RPC6801 ...69-71... 340/440 6-Pack, Upper Set
with 4 Lines, 2 Tees
- RPC6802 ...70-71... 340 6 Pack, Lower Set, with 2 Lines
- RPC6807 ...70-72... 383 with Carter AVS 2 Pcs.
- RPC6805 71 340 with Carter T-Quad 2 Pcs.
- RPC7101 71 Dart Sport, Weber 2 BBL
- RPC7201 72 440 with AVS 4 BBL 2 Pcs.
- RPC7202 72 340 with Carter T-Quad
- RPC7301 73 400 with Carter T-Quad
- RPC7501 75 360 with 2 BBL

FUEL TANK VENT LINES

Fuel tank vent lines allow the air inside the fuel tank to escape as it is filled with fuel. They also prevent pressure from building up due to temperature changes.

- RFV680168-70... All Cars, Except Charger - OE Steel..... 2 Pcs
- RFV6801S ...68-70... All Cars, Except Charger - Stainless..... 2 Pcs
- RFV680268-70... Charger Filler Neck Vent - OE Steel
- RFV6802S ...68-70... Charger Filler Neck Vent - Stainless

MOPAR B-BODY FUEL TANKS

FUEL SENDING UNITS

Sending units include floats, gaskets and snap rings where applicable. Our fuel senders are made of stainless steel and operate on the same ohm range as factory gauges.

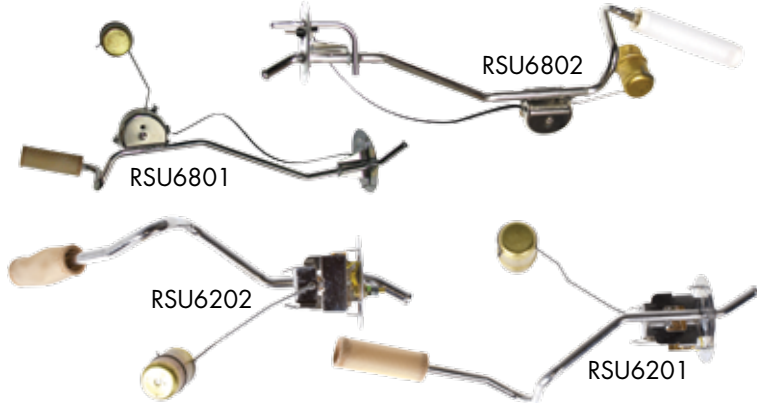

- RSU6201 62-65 5/16" Main
- RSU6202 62-65 3/8" Main
- RSU6801 68-70 5/16" Main
- RSU6802 68-70 3/8" Main
- RSU6822 68-70 1/2" Main
- RSU6601 66-67 5/16" Main
- RSU6602 66-67 3/8" Main
- RSU7104 71-74 3/8" Main

TRANSMISSION COOLER LINES

Transmission cooler lines are sold as pairs. Be sure to verify the type of transmission in your project before ordering. These lines are intended to work only with factory motor, transmission, and radiator combinations.

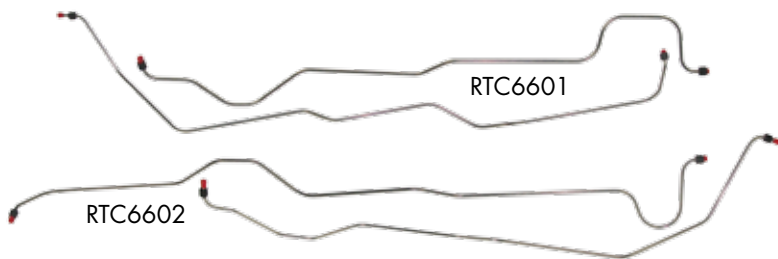

- RTC6301 63-65 All Cars, 2 Lines
- RTC6501 65 Big Block 2 Pcs.
- RTC6603 66-69 Hemi with Auxiliary Cooling, Except Charger with Hidden Headlights 4 Pcs.
- RTC6601 66-70 727 Small Block
- RTC6602 66-70 727 Big Block
- RTC6604 66 Hemi Charger with Hidden Headlights 4 Pcs.
- RTC6605 66-70 Small Block with 904 Trans.
- RTC7003 70 Hemi with Auxiliary Cooling, Except Charger with Hidden Headlights 4 Pcs.
- ETC7002 71-74 727 Big Block
- ETC7001 71-74 727 Small Block
- RTC7201 71-72 318ci with 904
- RTC7601 76-79 All 2 Pcs.

FUEL TANKS

Fuel tanks are made of Ni-Terne steel. Hardware is not included.



- RFT6817 68-70... without ECS (Except Charger/Wagons)
2 Vents on Front - Fuel Tank
- RST6817 68-70... without ECS (Except Charger/Wagons)
2 Vents on Front - Fuel Tank with Straps
- RFT6827 68-70... Charger without ECS - Fuel Tank
- RST6827 68-70... Charger without ECS - Fuel Tank with Straps



MOPAR B-BODY SUSPENSION & BRAKE LINES

SUSPENSION COMPONENTS

**COMING
IN 2017**

UPPER & LOWER BALL JOINTS



XK781..... 65-72 Lower, Right Hand, with Steering Arm
 XK783..... 65-72 Lower, Left Hand, with Steering Arm
 XK772..... 65-72 Upper

IDLER ARMS

**COMING
IN 2017**



RIA6567..... 65-67 All 40.95
 RIA6872..... 68-72 All 40.95

SWAY BAR LINK KITS

XK5255..... 70-72 All



INNER & OUTER TIE RODS & SLEEVES



XES319L..... 65-69 Inner
 XES319R 65-69 Outer
 XES401L..... 70-72 Inner
 XES401R 70-72 Outer
 XES319S 65-72 Adjusting Sleeve

UPPER & LOWER CONTROL ARM BUSHING KITS

XK408..... 65-72 Upper
 XK791..... 65-72 Lower



SWAY BAR BUSHING

XK5241..... 70-72 All



SUSPENSION KITS

Standard rubber kits meet O.E. specifications. Polyurethane kits provide better handling and a firmer ride. Poly kits include upgraded control arm bushings, sway bar bushings, and sway bar links. Pre-packaged kits offer huge savings over individual suspension parts. Most kits include the following:

**COMING
IN 2017**

- Lower Ball Joints (2)
- Upper Ball Joints (2)
- Lower Control Arm Bushings (4)
- Upper Control Arm Bushings (4)
- Strut Rod Bushings (2)
- Tie Rod Adj. Sleeves (2)
- Outer Tie Rods (2)
- Inner Tie Rods (2)



RSK6501 65 Front Rebuild Kit - Rubber 20 Pc.
 RSK6501U..... 65 Front Rebuild Kit - Polyurethane 20 Pc.
 RSK6669 66-69... Front Rebuild Kit - Rubber 20 Pc.
 RSK6669U... 66-69... Front Rebuild Kit - Polyurethane 20 Pc.
 RSK7072 70-72... Front Rebuild Kit - Rubber 20 Pc.
 RSK7072U... 70-72... Front Rebuild Kit - Polyurethane 20 Pc.

AXLE FLANGE DIAGRAMS

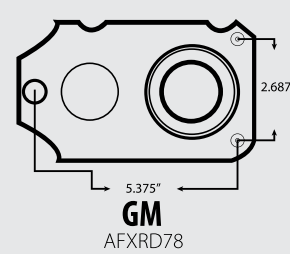
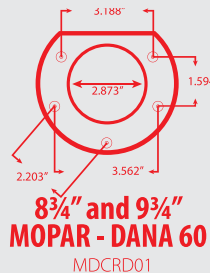
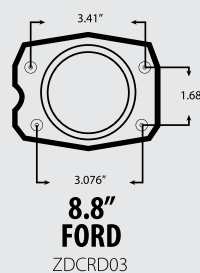
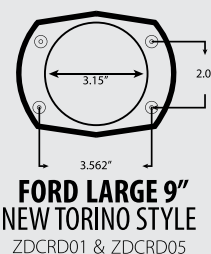
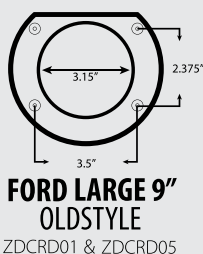
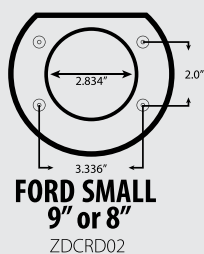
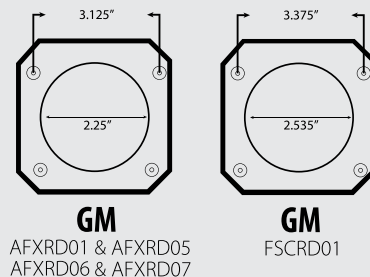
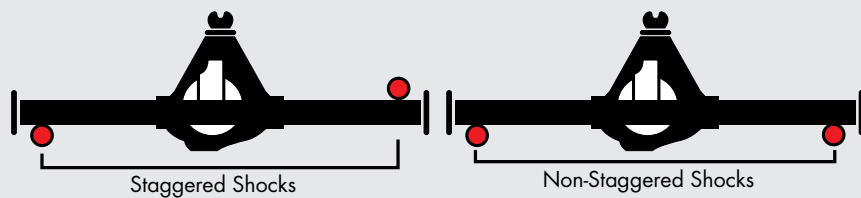

MOPAR B-BODY FRONT DISC CONVERSIONS

**STREET
SERIES**

U.S.A. Made
TIMKEN Bearings

FRONT DISC BRAKE CONVERSION KITS

FITS +15" WHEELS WITH A 5 X 4.5" BOLT PATTERN



FRONT CONVERSIONS INCLUDE:

- 11" Rotors (5 x 4.5")
- Forged Spindles
- Timken Bearings
- New Calipers
- Caliper Brackets
- Organic Pads
- Flex Hoses & Hardware
- Valve Bracket & Hardware
- Banjo Bolts & Copper Washers
- Dust Caps
- Castle Nuts & Pins
- Washers
- Grease Seals
- Steering Arm Bolts
- Master Cylinder
- Adjustable Valve
- 8" Dual Booster
- Backing Plates

Right Stuff disc conversions are the most complete kits in the industry at the right price. High quality components, professional packaging, and after-sale support by "hands-on" technicians create an unbeatable value. Consider one of our complete brake line packages for a carefree installation.

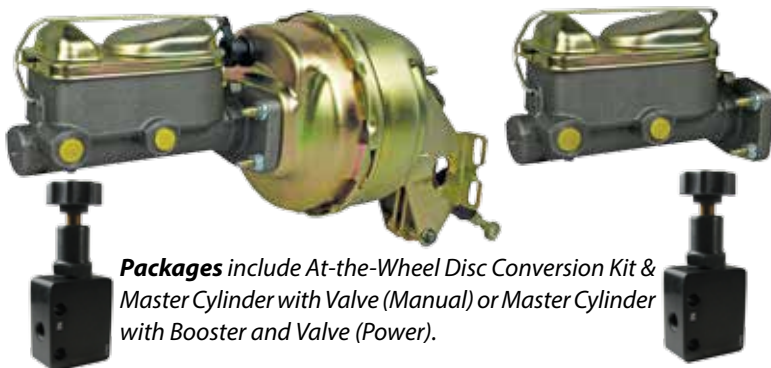

Packages include At-the-Wheel Disc Conversion Kit & Master Cylinder with Valve (Manual) or Master Cylinder with Booster and Valve (Power).

POWER PACKAGE

MANUAL PACKAGE

STOCK HEIGHT FRONT KITS

MDC62WK....62-72.... At-the-Wheel Disc Conversion Kit
MDC62SD62-72.... Manual Disc Conversion Package
MDC62DC.....62-72.... 8" Dual Power Disc Conversion Package

264

FRONT DISC BRAKE CONVERSION UPGRADES

SHOW'N GO UPGRADE TRIM KITS

At-the-Wheel Disc Conversion Kits include upgraded drilled slotted rotors with zinc plating, powder coated calipers in red or black, & braided stainless hoses.



STOCK HEIGHT SHOW'N GO

MDC62WKS... 62-72 At-the-Wheel Disc Conversion Kit - Black
MDC62WKZ... 62-72 At-the-Wheel Disc Conversion Kit - Red
MDC62SDS 60-76 Manual Disc Conversion Kit - Black
MDC62SDZ 60-76 Manual Disc Conversion Kit - Red
MDC62DCS.... 60-76 Power Disc Conversion Kit - Black
MDC62DCZ.... 60-76 Power Disc Conversion Kit - Red

SHOW STOPPER TRIM PACKAGES

Includes At-the-Wheel Front Disc Conversion Kit with natural finish calipers. The Manual Packages get an upgraded chrome plated master cylinder and combination valve with bracket. Power Packages include an upgraded 8" dual chrome booster.



STOCK HEIGHT SHOW STOPPER

MDC62SDX 62-72 ... Manual Disc Conversion Package
MDC62DCX.... 65-72 ... 8" Dual Power Disc Conversion Package

BEST OF SHOW TRIM PACKAGES

Includes At-the-Wheel Front Disc Conversion Kit with black or red calipers. The Manual Packages get an upgraded chrome plated master cylinder and combination valve with bracket. Power Packages include an upgraded 8" dual chrome booster.

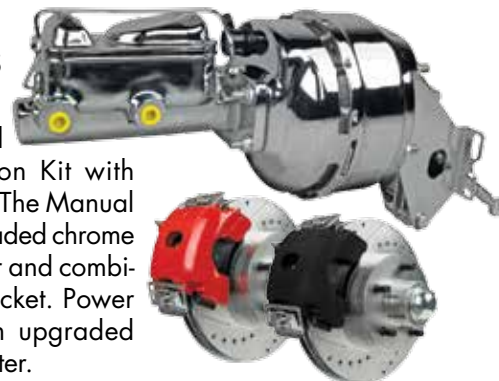

STOCK HEIGHT BEST OF SHOW

MDC62SDSX ... 62-72 ... Manual Disc Conversion Package - Black
MDC62SDZX ... 62-72 ... Manual Disc Conversion Package - Red
MDC62DCSX... 65-72 ... 8" Dual Power Disc Conversion Pkg - Black
MDC62DCZX... 65-72 ... 8" Dual Power Disc Conversion Pkg - Red

MOPAR B-BODY 4-WHEEL DISC CONVERSIONS

**STREET
SERIES**

FOUR WHEEL DISC BRAKE CONVERSION KITS

 U.S.A. Made **TIMKEN** Bearings

FRONT CONVERSIONS INCLUDE:

- 11" Rotors (5 X 4.5")
- Forged Spindles
- Timken Bearings
- New Calipers
- Caliper Brackets
- Organic Pads
- Backing Plates
- Flex Hoses & Hardware
- Banjo Bolts & Copper Washers
- Dust Caps
- Castle Nuts & Pins
- Washers
- Grease Seals
- Steering Arm Bolts
- Master Cylinder
- 8" Dual Booster
- Adjustable Valve
- Pedal Rod Extension

REAR CONVERSIONS INCLUDE:

- 11.25" Rotors
- Caliper Brackets & Spacers
- Weld-On Hose Brackets
- New Loaded Caliper
- E-Brake Cables
- Flex Hoses

High quality components, & after the sale support by "hands-on" technicians. Complete brake line packages are available for a care free installation. Verify axle flange measurements for these kits.

WORKS WITH 15" AND LARGER WHEELS WITH 5 X 4.5" BOLT PATTERN

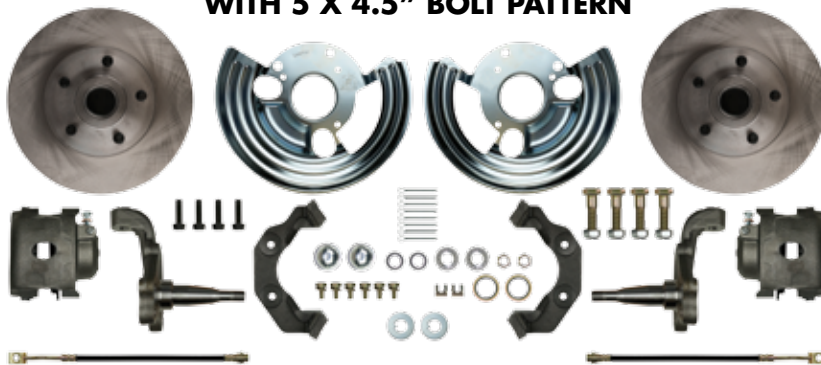

AT-THE-WHEEL FRONT KIT

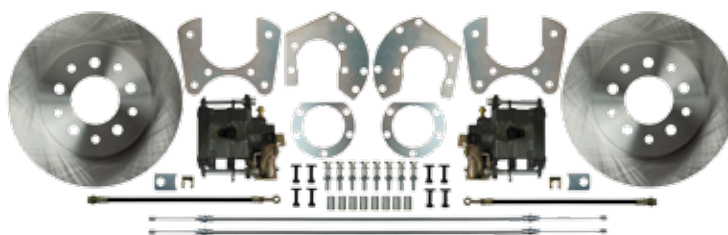

AT-THE-WHEEL REAR KIT



GREEN BEARINGS REQUIRED

Packages include At-the-Wheel Disc Conversion Kit & Master Cylinder with Valve (Manual) or Master Cylinder with Booster and Valve (Power).

POWER PACKAGE

MANUAL PACKAGE

STOCK HEIGHT 4-WHEEL KITS

- MDC42SD 62-72 Manual Disc Conversion Package
MDC42DC..... 65-72 8" Dual Power Disc Conversion Package
WBK04 62-72 Green Bearing Set (2 Pcs)

4-WHEEL DISC BRAKE CONVERSION UPGRADES

BEST OF SHOW TRIM PACKAGES



Includes At-the-Wheel Front Disc Conversion Kit

with black or red calipers. Manual Packages get an upgraded chrome plated master cylinder & combination valve with bracket. Power Packages include an upgraded 8" dual chrome booster.

STOCK HEIGHT BEST OF SHOW

- MDC42SDSX ... 62-72 ... Manual Disc Conversion Package - Black
MDC42SDZX ... 62-72 ... Manual Disc Conversion Package - Red
MDC42DCSX... 65-72 ... 8" Dual Power Disc Conv Package - Black
MDC42DCZX... 65-72 ... 8" Dual Power Disc Conv Package - Red

SHOW'N GO UPGRADE TRIM KITS

These At-the-Wheel Disc Conversion Kits (stock height or 2" drop) include upgraded drilled slotted rotors with zinc plating, powder coated calipers in red or black, and braided stainless hoses.

SHOW STOPPER TRIM PACKAGES



Includes At-the-Wheel Front Disc Conversion Kit with natural finish calipers. The Manual Packages get an upgraded chrome plated master cylinder and combination valve with bracket. Power Packages include an upgraded 8" dual chrome booster.

STOCK HEIGHT SHOW STOPPER

- MDC42SDX ... 62-72 ... Manual Disc Conversion Package
MDC42DCX... 65-72... 8" Dual Power Disc Conversion Package

STOCK HEIGHT SHOW'N GO

- MDC42SDS ... 62-72 ... Manual Disc Conversion Pkg - Black
MDC42SDZ ... 62-72 ... Manual Disc Conversion Pkg - Red
MDC42DCS... 62-72 ... Power Disc Conversion Pkg - Black
MDC42DCZ... 62-72 ... Power Disc Conversion Pkg - Red

MOPAR B-BODY REAR DISC CONVERSIONS

**STREET
SERIES**

REAR DISC BRAKE CONVERSION KITS

REAR CONVERSIONS INCLUDE:

- 11.25" Rotors (5 x 4.5")
- New Loaded Calipers
- Caliper Brackets & Spacers
- Weld-On Hose Brackets
- Flex Hoses
- Hardware

NOTE:

FITS FACTORY
REAR ENDS
CALL FOR CUSTOM
APPLICATIONS

Right Stuff disc conversions are the most complete kits in the industry at the right price. High quality components, professional packaging, and after-sale support by "hands-on" technicians create an unbeatable value. Consider one of our complete brake line packages for a carefree installation. See page 261 to verify axle flange measurements for these kits.

WORKS WITH 15" AND LARGER WHEELS WITH 5 X 4.5" BOLT PATTERN

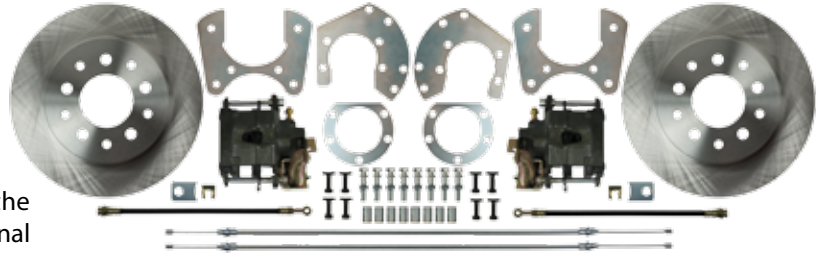

6-5/16" INSIDE ROTOR DIAMETER - 2.85" CENTER HOLE

GREEN BEARINGS REQUIRED

Green bearings allow our caliper brackets to bolt securely to the axle flange. We offer the bearings in a set as part# WBK04. Not recommended for extreme road course applications.

ATTENTION Before you order, be sure to measure the axle flange on your vehicle.

KITS WITH NON-E-BRAKE CALIPERS

- MDCRD162-72..... Rear Disc Conversion (Use OE Cables)
- WBK0460-76..... Green Bearing Set (2 Pcs)

KITS WITH E-BRAKE CALIPERS

- MDCRDM160-76..... 8-3/4", 9-3/4", Dana 60
- WBK0460-76..... Green Bearing Set (2 Pcs)

KITS WITH E-BRAKE - REAR CABLE

- MDCRRO1.....63-65..... Rear Disc Dodge
- MDCRRO2.....63-65..... Rear Disc Plymouth
- MDCRRO3.....66-70..... Rear Disc All Cars
- MDCRRO4.....71-72..... Rear Disc All Cars
- MDCRRO5.....73-74..... Rear Disc All Cars
- WBK0460-76..... Green Bearing Set (2 Pcs)

REAR DISC BRAKE CONVERSION UPGRADES

**STREET
SERIES**

SHOW'N GO UPGRADE TRIM PACKAGES

These At-the-Wheel Rear Disc Conversion Kits (stock height or 2" drop) include upgraded drilled slotted rotors with zinc plating, powder coated calipers in red or black, and braided stainless hoses.



KITS WITH NON-E-BRAKE CALIPERS

- MDCRD1S62-72... Rear Disc Conv - Black (Use OE Cables)
- MDCRD1Z62-72... Rear Disc Conv - Red (Use OE Cables)
- WBK0460-76... Green Bearing Set (2 Pcs)

KITS WITH E-BRAKE CALIPERS

- MDCRDM1S 60-76 8-3/4", 9-3/4", Dana 60 - Black
- MDCRDM1Z 60-76 8-3/4", 9-3/4", Dana 60 - Red
- WBK0460-76 Green Bearing Set (2 Pcs)

KITS WITH E-BRAKE - REAR CABLE

- MDCRRO1S..... 63-65 Rear Disc Dodge - Black
- MDCRRO1Z..... 63-65 Rear Disc Dodge - Red
- MDCRRO2S..... 63-65 Rear Disc Plymouth - Black
- MDCRRO2Z..... 63-65 Rear Disc Plymouth - Red
- MDCRRO3S..... 66-70 Rear Disc All Cars - Black
- MDCRRO3Z..... 66-70 Rear Disc All Cars - Red
- MDCRRO4S..... 71-72 Rear Disc All Cars - Black
- MDCRRO4Z..... 71-72 Rear Disc All Cars - Red
- MDCRRO5S..... 73-74 Rear Disc All Cars - Black
- MDCRRO5Z..... 73-74 Rear Disc All Cars - Red
- WBK0460-76 Green Bearing Set (2 Pcs)



No Brainer BRAKE LINE KITS

DESIGNED FOR DISC CONVERSIONS

When you add disc brakes to your Mopar you normally have to incorporate an adjustable valve into the system & in the case of cars dating prior to 1967 you have an extra port on the master cylinder to contend with. Even if your lines are brand new or great originals, you are going to have a couple of issues trying to use them. Our Mopar 'No Brainer Brake Line Kit' fixes all these issues from your master cylinder all the way back to your rear wheel cylinders or rear calipers. We give you all the lines to complete the installation. We also include the rear flex hose & a full clip set to install your lines. Extremely discounted prices and great instructions make this kit a No Brainer.

SIMPLIFY YOUR DISC BRAKE CONVERSION INSTALLATION WITH ALL OF THE BRAKE LINES YOU WILL NEED.

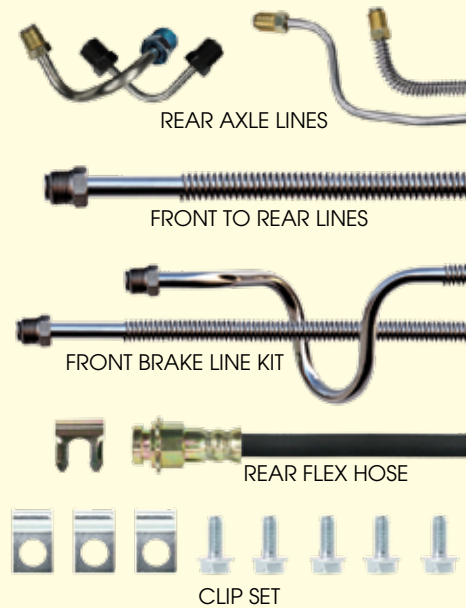

MANUAL - NO VACUUM BOOSTER FRONT DISC/REAR DRUM LINES

62 - 65 DODGE

RM62U2D ..62-64...Non-Max Wedge, Dodge
RM62O2D ..62-64...Max Wedge, Dodge
RM65U2D65Dodge

62 - 65 PLYMOUTH

RM62U2P ..62-64...Non-Max Wedge, Plymouth
RM62O2P ..62-64...Max Wedge, Plymouth
RM65U2P65Plymouth

66-67 FIREWALL LINE (STRAIGHT ACROSS)

RM66U266 Straight Above Bellhousing, 8-3/4"
RM66U766 Straight Above Bellhousing, Dana
RM67U267 Straight Above Bellhousing, 8-3/4"
RM67U767 Straight Above Bellhousing, Dana

66-67 FIREWALL LINE 4" ACROSS FIREWALL

RM66O2 664" Rise Above Bellhousing, 8-3/4"
RM66O7 664" Rise Above Bellhousing, Dana
RM67O2 674" Rise Above Bellhousing, 8-3/4"
RM67O7 674" Rise Above Bellhousing, Dana

68-70 FIREWALL LINE UNDER PASS FRAMERAIL

RM68U268-69...Under Passenger Frame, 8-3/4"
RM68U768-69...Under Passenger Frame, Dana
Call Us!70Under Passenger Frame, 8-3/4"
Call Us!70Under Passenger Frame, Dana

68-70 FIREWALL LINE OVER PASS FRAMERAIL

RM68O268-69...Over Passenger Frame, 8-3/4"
RM68O768-69...Over Passenger Frame, Dana
RM70O270Over Passenger Frame, 8-3/4"
RM70O770Over Passenger Frame, Dana

1971-72

RM71U2718-3/4" Rear End
RM71U771Dana Rear End
RM72U2728-3/4" Rear End
RM72U772Dana Rear End

POWER - WITH VACUUM BOOSTER FRONT DISC/REAR DRUM LINES

62 - 65 DODGE

RP62U2D62-64...Non-Max Wedge, Dodge
RP62O2D ...62-64...Max Wedge, Dodge
RP65U2D65Dodge

62 - 65 PLYMOUTH

RP62U2P62-64...Non-Max Wedge, Plymouth
RP62O2P62-64...Max Wedge, Plymouth
RP65U2P65Plymouth

66-67 FIREWALL LINE (STRAIGHT ACROSS)

RP66U266 Straight Above Bellhousing, 8-3/4"
RP66U766 Straight Above Bellhousing, Dana
RP67U267 Straight Above Bellhousing, 8-3/4"
RP67U767 Straight Above Bellhousing, Dana

66-67 FIREWALL LINE 4" ACROSS FIREWALL

RP66O2 664" Rise Above Bellhousing, 8-3/4"
RP66O7 664" Rise Above Bellhousing, Dana
RP67O2 674" Rise Above Bellhousing, 8-3/4"
RP67O7 674" Rise Above Bellhousing, Dana

68-70 FIREWALL LINE UNDER PASS FRAMERAIL

RP68U268-69...Under Passenger Frame, 8-3/4"
RP68U768-69...Under Passenger Frame, Dana
Call Us!70Under Passenger Frame, 8-3/4"
Call Us!70Under Passenger Frame, Dana

68-70 FIREWALL LINE OVER PASS FRAMERAIL

RP68O268-69...Over Passenger Frame, 8-3/4"
RP68O768-69...Over Passenger Frame, Dana
RP70O270Over Passenger Frame, 8-3/4"
RP70O770Over Passenger Frame, Dana

1971-72

RP71U2718-3/4" Rear End
RP71U771Dana Rear End
RP72U2728-3/4" Rear End
RP72U772Dana Rear End

MOPAR B-BODY BRAKE LINES

MANUAL - NO VACUUM BOOSTER

4-WHEEL DISC MANUAL LINES

62 - 65 DODGE

RM62U4D ..62-64...Non-Max Wedge, Dodge
RM62O4D ..62-64...Max Wedge, Dodge
RM65U4D65Dodge

62 - 65 PLYMOUTH

RM62U4P ...62-64...Non-Max Wedge, Plymouth
RM62O4P ..62-64...Max Wedge, Plymouth
RM65U4P65Plymouth

66-67 FIREWALL LINE (STRAIGHT ACROSS)

RM66U4.....66 Straight Above Bellhousing, 8-3/4"
RM66U8.....66 Straight Above Bellhousing, Dana
RM67U4.....67 Straight Above Bellhousing, 8-3/4"
RM67U8.....67 Straight Above Bellhousing, Dana

66-67 FIREWALL LINE 4" ACROSS FIREWALL

RM66O4664" Rise Above Bellhousing, 8-3/4"
RM66O8664" Rise Above Bellhousing, Dana
RM67O4674" Rise Above Bellhousing, 8-3/4"
RM67O8674" Rise Above Bellhousing, Dana

68-70 FIREWALL LINE UNDER PASS FRAMERAIL

RM68U4.....68-69...Under Passenger Frame, 8-3/4"
RM68U8.....68-69...Under Passenger Frame, Dana
Call Us!70Under Passenger Frame, 8-3/4"
Call Us!70Under Passenger Frame, Dana

68-70 FIREWALL LINE OVER PASS FRAMERAIL

RM68O468-69...Over Passenger Frame, 8-3/4"
RM68O868-69...Over Passenger Frame, Dana
RM70O470Over Passenger Frame, 8-3/4"
RM70O870Over Passenger Frame, Dana

1971-72

RM71U4.....718-3/4" Rear End
RM71U8.....71Dana Rear End
RM72U4.....728-3/4" Rear End
RM72U8.....72Dana Rear End

POWER - WITH VACUUM BOOSTER

4-WHEEL DISC POWER LINES

62 - 65 DODGE

RP62U4D....62-64...Non-Max Wedge, Dodge
RP62O4D...62-64...Max Wedge, Dodge
RP65U4D.....65Dodge

62 - 65 PLYMOUTH

RP62U4P ...62-64...Non-Max Wedge, Plymouth
RP62O4P...62-64...Max Wedge, Plymouth
RP65U4P65Plymouth

66-67 FIREWALL LINE (STRAIGHT ACROSS)

RP66U4.....66 Straight Above Bellhousing, 8-3/4"
RP66U8.....66 Straight Above Bellhousing, Dana
RP67U4.....67 Straight Above Bellhousing, 8-3/4"
RP67U8.....67 Straight Above Bellhousing, Dana

66-67 FIREWALL LINE 4" ACROSS FIREWALL

RP66O4664" Rise Above Bellhousing, 8-3/4"
RP66O8664" Rise Above Bellhousing, Dana
RP67O4674" Rise Above Bellhousing, 8-3/4"
RP67O8674" Rise Above Bellhousing, Dana

68-70 FIREWALL LINE UNDER PASS FRAMERAIL

RP68U4.....68-69...Under Passenger Frame, 8-3/4"
RP68U8.....68-69...Under Passenger Frame, Dana
Call Us!70Under Passenger Frame, 8-3/4"
Call Us!70Under Passenger Frame, Dana

68-70 FIREWALL LINE OVER PASS FRAMERAIL

RP68O468-69...Over Passenger Frame, 8-3/4"
RP68O868-69...Over Passenger Frame, Dana
RP70O470Over Passenger Frame, 8-3/4"
RP70O870Over Passenger Frame, Dana

1971-72

RP71U4.....718-3/4" Rear End
RP71U8.....71Dana Rear End
RP72U4.....728-3/4" Rear End
RP72U8.....72Dana Rear End

FRONT BRAKE LINE KITS

Front brake line kits consist of all brake lines under the hood. This includes the master cylinder to the distribution, combination or metering valve. The left and right front lines that run to the front flex hoses are also included. Call for individual component pricing. These line kits are for vehicles with factory brake systems.



HKT6501

ADD "S" TO PART NUMBER FOR STAINLESS STEEL

RKT540154 Manual Drum, Belvedere,	
		Includes Wheel Line	9 Pcs.
HKT570157 Manual Drum	4 Pcs.
HKT6101	.. 60-61	... Fury, Newport, Manual Drum ...	5 Pcs.
HKT610261 300 G, Power Drum	4 Pcs.
HKT610661 Imperial Manual Drum	3 Pcs.
HKT610361 Fury Power Drum	3 Pcs.
HKT643064 Chrysler 300K, Power Drum	3 Pcs.
HKT6401	.. 64-66	... Imperial, Power Drum	3 Pcs.
HKT650165 Fury with Manual Drum	3 Pcs.
HKT650265 Fury with Power Drum	3 Pcs.
HKT650665 Polara with Pwr. Drum	3 Pcs.
HKT660166 Newport, Manual Drum	3 Pcs.
HKT660266 Fury with Manual Drum	3 Pcs.
HKT660366 Fury with Power Drum	3 Pcs.

HKT660466 Wide Body, Standard Drum	3 Pcs.
HKT660566 Wide Body, Power Drum	3 Pcs.
HKT670167 Fury, Manual & Power Drum	4 Pcs.
HKT680168 Manual Drum	4 Pcs.
HKT680268 Pwr Drum	5 Pcs.
HKT680268 Imperial, Power Disc	5 Pcs.
HFC680268 Caliper Lines	2 Pcs.
HKT680368 Fury with Power Disc	5 Pcs.
HKT690469 Chrysler 300	3 Pcs.
HKT6901	.. 69-71	... Manual Drum	4 Pcs.
HKT6902	.. 69-71	... Power Disc	5 Pcs.
HKT6903	.. 69-71	... Power Drum	4 Pcs.
HKT6905	.. 69-71	... Police Special, Power Disc	5 Pcs.
HKT720172 Power Disc	4 Pcs.
HKT730173 Power Disc	4 Pcs.
HKT770177 Power Disc, Fury	4 Pcs.

FRONT TO REAR BRAKE LINES

Front to rear lines go from the distribution, combination or metering valve along the length of the vehicle to the rear flex hose.

ADD "S" TO PART NUMBER FOR STAINLESS STEEL

RIN5401 54Belvedere
HIN5701 57Fury
HIN6001 60Chrysler 300
HIN6003 60Fury, Newport
HIN6101 61Chrysler 300
HIN6106 61Imperial
HIN6102 61Fury Power Drum
HIN6201 62All Cars
HIN6430 64Chrysler 300K
HIN6401 64-66Imperial
HIN6501 65Fury
HIN6502 65Fury Sport, Power Drum
HIN6502 65Max Wedge, Street Wedge, Pwr.
HIN6506 65Polara, Power Drum
HIN6601 66Fury, Newport
HIN6602 66318 Wide Body, Power Drum
HIN6603 66Newport, New Yorker, Power Drum
HIN6701 67-68All Cars
HIN6802 68Front/Rear Brakes
HIN6901 69-70All Cars
HIN7201 71-72Fury
HIN7701 77Fury, 4 Door
HIN8201 82Grand Fury

REAR AXLE BRAKE LINES

Rear axle brake lines include a pair of lines that run across the rear axle housing. These lines connect the wheel cylinders or calipers to the flex hose in the middle of the rear end. These lines work with original housings that use factory brakes. Modifications such as rear disc brakes or narrowed rear ends will likely require special lines. Call for more information.

ADD "S" TO PART NUMBER FOR STAINLESS STEEL

HRA5701 57Chrysler 300
HRA6001 60Chrysler 300
HRA6101 61Newport
HRA6102 61Chrysler 300
HRA6106 61Imperial
HRA6103 61Fury
HRA6201 62Fury
HRA6401 64Plymouth Fury
HRA6402 64Imperial
HRA6430 64Chrysler 300K
HRA6506 65Polara
HRA6502 65-66 Sport Fury, Max Wedge
HRA6701 67All Cars
HRA6801 68All Cars
HRA6802 68Imperial
HRA6901 69-71All Cars
HRA7201 72Fury
HRA7301 73Fury
HRA7701 77Fury

MOPAR C & D-BODY FUEL & BRAKE LINES

FRONT BRAKE FLEX HOSES

Front flex hoses provide a flexible connection from the body or frame to the front calipers or wheel cylinders as they move during suspension travel. Choose between O.E. rubber or braided stainless steel. All of our hoses are D.O.T. approved. Hoses are priced individually.



ADD "S" TO PART NUMBER FOR STAINLESS STEEL

- FH80 65-69 Drum
- FH42.....68 Budd Disc
- FH84..... 69-72 Disc

REAR BRAKE FLEX HOSES

Rear flex hoses carry brake fluid between the body of the car and the rear. Hoses are available in O.E. rubber and braided stainless steel. 'T' blocks are attached whenever factory correct. All of our hoses are D.O.T. approved. Prices are per hose.

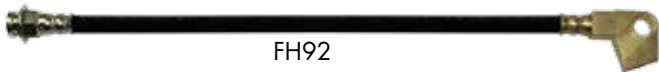

ADD "S" TO PART NUMBER FOR STAINLESS STEEL

- FH89..... 65-69 without 440, 4 Speed
- FH91..... 67-69 with 440, 4 Speed
- FH92..... 75-78 Fury

VALVES & BLOCKS

We offer a full line of metering blocks, proportioning valves, distribution blocks & combination valves for factory drum & disc brake applications.



- RSBB12162-64..... Dual Master Conversion Block
- RSBB12365-66..... Dual Master Conversion Block
- RMB680168-70..... Brake Hold-Off Valve
- PV01 All Adjustable Proportioning Valve

MAIN FUEL LINES

Main lines carry fuel from the tank in the rear of the car to the fuel pump or rail in the front. They are available in 3/8" and 5/16" tubing based on factory specifications. Multiple piece sets are noted. Call for 1/2" lines.

ADD "S" TO PART NUMBER FOR STAINLESS STEEL

- RGL5401 54..... Belvedere 2 Pcs.
- HGL5701 57..... 5/16"
- HGL5801 58..... Main Fuel Line
- HGL6001 60..... 5/16" Plymouth Fury 2 Pcs.
- HGL6002 60..... Chrysler 300 2 Pcs.
- HGL6002 60..... 5/16" Sport Fury
- HGL6005 60..... 5/16" New Yorker
- HGL6101 61-62 126" Wheelbase Cars..... 2 Pcs.
- HGL6106 61..... Imperial
- HGL6201 61-62 122" Wheelbase Cars..... 2 Pcs.
- HGL6102 61..... 5/16" Fury V-8 383 2 Pcs.
- HGL6202 62..... Chrysler 300
- HGL6401 64..... 5/16" Plymouth Fury
- HGL6430 64..... 5/16" Chrysler 300K..... 2 Pcs.
- HGL6502 65..... 5/16" Sport Fury
- HGL6503 65..... Imperial, Convertible
- HGL6501 65-66 Fury..... 2 Pcs.
- HGL6701 67..... 5/16" Fury 2 Pcs.
- HGL6801 68..... 5/16" Main Fuel..... 2 Pcs.
- HGL6803 68..... 5/16" Fury Wagon 2 Pcs.
- HGL6901 69-71 5/16" Hardtop 2 Pcs.
- HGL6902 69-71 5/16" Convertible 2 Pcs.
- HGL7201 72..... 5/16" Main Line..... 2 Pcs.
- HGL7301 73..... 5/16" Main Line..... 2 Pcs.
- HGL7601 76..... 5/16" 5th Ave.
- HGL7801 78..... 3/8" Fury

E-BRAKE CABLES

Parking brake cable sets contain all the individual cables and hardware needed to restore the system. Front, rear, and intermediate cables are also sold individually. While supplies last. O.E. mild steel & stainless steel.

• E-Brake Cable Kits

- RSBCH01 65-66 C Body Cars Only - OE Steel
- RSBCH01S.... 65-66 C Body Cars Only - Stainless

• Front Brake Cables

- EBC7033..... 65-66 C Body Cars Only - OE Steel
- EBC7033S.... 65-66 C Body Cars Only - Stainless

• Rear Brake Cables

- EBC9035..... 65-66 Short - OE Steel
- EBC9035S.... 65-66 Short - Stainless
- EBC9036..... 65-66 Long - OE Steel
- EBC9036S.... 65-66 Long - Stainless

HOSE BLOCKS

Breather bolts vent the rear end and hold the distribution block to the housing. Some cars have a block crimped directly to the hose. Others use the screw on blocks listed here. Verify the specifics of your application before ordering.

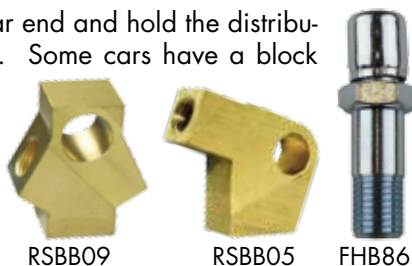

FHB86 Breather Bolt
 RSBBO5 "L" Block on Rear Axle
 RSBBA9 65-69 "Y" Block on Rear Axle

FUEL PUMP TO CARB LINES

Fuel pump to carburetor lines connect the fuel pump to the carburetor. Brass blocks and fittings are included as noted. These lines are intended to work only with factory pump, motor, intake and carburetor combinations.

ADD "S" TO PART NUMBER FOR STAINLESS STEEL

RPC5601 56 Single, 4 BBL
 SPC5701 57 Custom 300 4 Pcs.
 RPC5801 58 392, with 2x4's 3 Pcs.
 HPC6102 61 413, 4 BBL 3 Pcs.
 HPC6401 .. 64-66 .. 413, Imperial 2 Pcs.
 HPC6502 65 426 S.Wedge, 3859s Carb. 2 Pcs.
 HPC6702 67 318, 2 BBL 2 Pcs.
 HPC6801 68 383, 2 BBL 2 Pcs.
 HPC7001 70 Polara, 318ci, 2 BBL
 HPC7201 72 360, 2 BBL

VAPOR RETURN LINES

Emission control systems use these 5/16" lines to handle fuel vapors. Some vehicles use a single front to rear line. Others utilize a charcoal canister and require 3 or 4 additional small lines. Multiple piece sets are noted.

HGL6903 71 Vapor Return Lines - OE Steel 2 Pcs.
 HGL6903S 71 Vapor Return Lines - Stainless 2 Pcs.
 HGL7603 76 3/16" Vapor, 5th Ave. - OE Steel
 HGL7603S 76 3/16" Vapor, 5th Ave. - Stainless

RETURN FUEL LINES

Return lines carry excess fuel from fuel pump or fuel filter back to the tank. Not all vehicles were equipped with a return line. They are typically made of 1/4" diameter tubing. Multiple piece sets are noted.

HGL7202 72 1/4" Return Line - OE Steel 2 Pcs.
 HGL7202S 72 1/4" Return Line - Stainless 2 Pcs.
 HGL7302 73 1/4" Return Line - OE Steel 2 Pcs.
 HGL7302S 73 1/4" Return Line - OE Steel 2 Pcs.
 HGL7602 76 1/4" Return, 5th Ave. - OE Steel
 HGL7602S 76 1/4" Return, 5th Ave. - Stainless

TRANSMISSION COOLER LINES

Transmission cooler lines are sold as pairs. Be sure to verify the type of transmission in your project before ordering. These lines are intended to work only with factory motor, transmission, and radiator combinations.

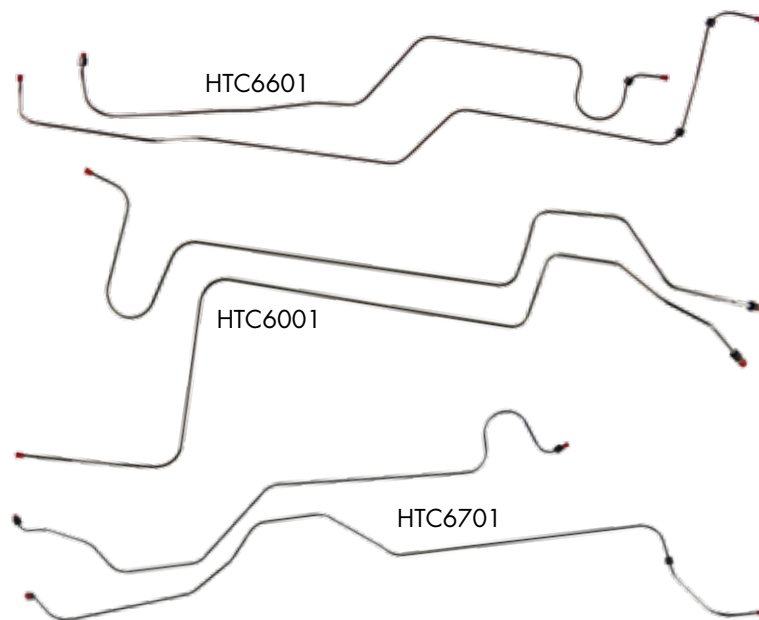

ADD "S" TO PART NUMBER FOR STAINLESS STEEL

HTC5701 57 300
 HTC6001 60-61 300 with 413 Cast Iron, T-Flyte
 RTC6201 62 Sport Fury, T-Flyte
 RTC6302 63 318 with 727, Polara
 HTC6401 64-66 413 with 727, Imperial
 HTC6502 65 727
 HTC6601 66 Small Block with 727
 HTC6702 67 Small Block with 727
 HTC6701 67-68 Big Block with 727
 HTC6802 68 Big Block with 727
 HTC6901 69-71 Big Block with 727
 HTC7001 70 318 ci with 904

FUEL TANK VENT LINES

Fuel tank vent lines allow the air inside the fuel tank to escape as it is filled with fuel. They also prevent pressure from building up due to temperature changes.

RFV5401 54 Belvedere - OE Steel
 RFV5401S 54 Belvedere - Stainless
 HFV6005 60 New Yorker, 1/4" - OE Steel
 HFV6005S 60 New Yorker, 1/4" - Stainless
 HFV6501 65 Fury - OE Steel
 HFV6501S 65 Fury - Stainless
 HFV6701 67 Fury - OE Steel 2 Pcs.
 HFV6701S 67 Fury - Stainless 2 Pcs.

MOPAR E-BODY BRAKE LINES & HOSES

FRONT BRAKE LINE KITS

Front brake line kits consist of all brake lines under the hood. This includes the master cylinder to the distribution, combination or metering valve. The left and right front lines that run to the front flex hoses are also included. Call for individual component pricing. Line kits are for vehicles with factory brake systems.

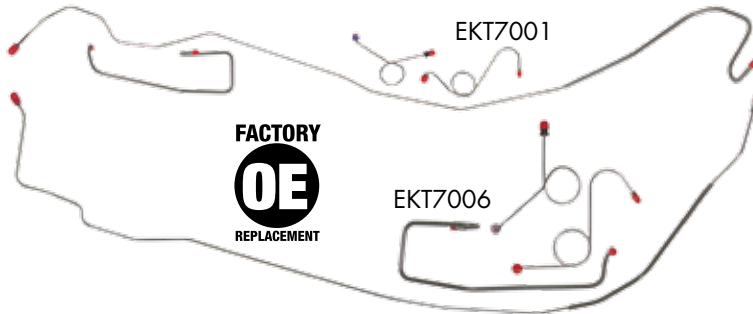

ADD "S" TO PART NUMBER FOR STAINLESS STEEL

- EKT7003 .. 70-71 ... Power Disc, Firewall Line Runs Under Frame, Uses 1 Pc Intermediate..... 5 Pcs.
- EKT7004 .. 70-71 ... Power Disc, Uses 2 Pc. Intermediate F.W. Line Runs Under Frame 5 Pcs.
- EKT7005 .. 70-71 ... Hemi Power Disc, Firewall Line Runs Under Frame, Uses 1 Pc. Intermediate..... 5 Pcs.
- EKT7007 .. 70-71 ... Power Drum, Firewall Line Runs Over Frame..... 4 Pcs.
- EKT7008 .. 70-71 ... Power Disc, Firewall Line Runs Over Frame, Uses 1 Pc. Intermediate..... 5 Pcs.
- EKT7009 .. 70-71 ... Power Disc, Firewall Line Runs Over Frame, Uses 2 Pc. Intermediate..... 5 Pcs.
- EKT7001 .. 70-73 ... Standard Drum, Firewall Line Runs Under Frame 4 Pcs.
- EKT7002 .. 70-73 ... Power Drum, Firewall Line Runs Under Frame 4 Pcs.
- EKT7006 .. 70-73 ... Standard Drum, Firewall Line Runs Over Frame..... 4 Pcs.
- EKT7203 .. 72-73 ... Power Disc 4 Pcs.
- EKT720474 Manual Disc 4 Pcs.
- EKT740174 Power Disc 4 Pcs.
- EKT7002 .. 70-73 ... Power Drum, Firewall Line Runs Under Frame 4 Pcs.
- EKT7006 .. 70-73 ... Standard Drum, Firewall Line Runs Over Frame..... 4 Pcs.
- EKT7203 .. 72-73 ... Power Disc 4 Pcs.
- EKT720474 Manual Disc 4 Pcs.
- EKT740174 Power Disc 4 Pcs.

BRAKE LINE CLIPS

Brake line clip sets contain all the clips needed to fasten the brake tubes to the frame or body of the car. Individual clips and fasteners are available on pages 284-285.



- ECS00170-74..... Brake Line Clip Set

FRONT BRAKE FLEX HOSES

Front flex hoses provide a flexible connection from the body or frame to the front calipers or wheel cylinders as they move during suspension travel. Choose between O.E. rubber or braided stainless steel. All hoses are D.O.T. approved. Priced individually.

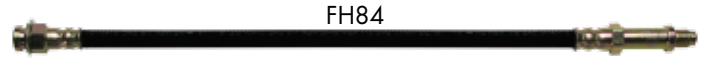

- FH81 70-72 Drum - OE Steel
- FH81S 70-72 Drum - Stainless
- FH84 70-73 Disc - OE Steel
- FH84S 70-73 Disc - Stainless
- FH184 74 Front Disc - OE Steel

REAR BRAKE FLEX HOSES

Rear flex hoses carry brake fluid between the body of the car and the rear. Hoses are available in O.E. rubber and braided stainless steel. 'T' blocks are attached whenever factory correct. All of our hoses are D.O.T. approved. Prices are per hose.

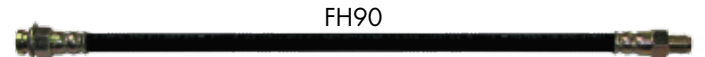

- FH92 70 70's with Block - OE Steel
- FH92S 70 70's with Block - Stainless
- FH90 70-71 Correct For 70's without Block - OE Steel
- FH90S 70-71 Correct For 70's without Block - Stainless
- FH86 72-74 All Cars - OE Steel
- FH86S 72-74 All Cars - Stainless

FRONT TO REAR BRAKE LINES

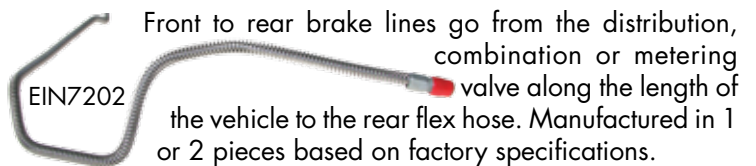

ADD "S" TO PART NUMBER FOR STAINLESS STEEL

- EIN7003 70-74 Cuda 1 Pc.
- EIN7004 70-74 Cuda 2 Pc.
- EIN7007 70-74 Challenger 1 Pc.
- EIN7008 70-71 Challenger 2 Pc.
- EIN7201 72-74 Cuda, Disc Brakes..... 1 Pc.
- EIN7202 72-74 Challenger, Disc Brakes 1 Pc.

REAR AXLE BRAKE LINES

Rear axle brake lines include a pair of lines that run across the rear axle housing. These lines connect the wheel cylinders or calipers to the flex hose in the middle of the rear end. These lines work with original housings that use factory brakes. Modifications such as rear disc brakes or narrowed rear ends will likely require special lines. Call for more information.

- ERA700170-74..... 8-3/4 Rear Axle - OE Steel
- ERA7001S70-74..... 8-3/4 Rear Axle - Stainless
- ERA700270-74..... Dana Rear Axle - OE Steel
- ERA7002S70-74..... Dana Rear Axle - Stainless

E-BRAKE CABLES

Parking brake cable sets contain all the individual cables & hardware. Front, rear, & intermediate cables are also sold individually while supplies last. Sold in O.E. mild steel and stainless steel. See our rear disc brake cables if you have a rear disc conversion.

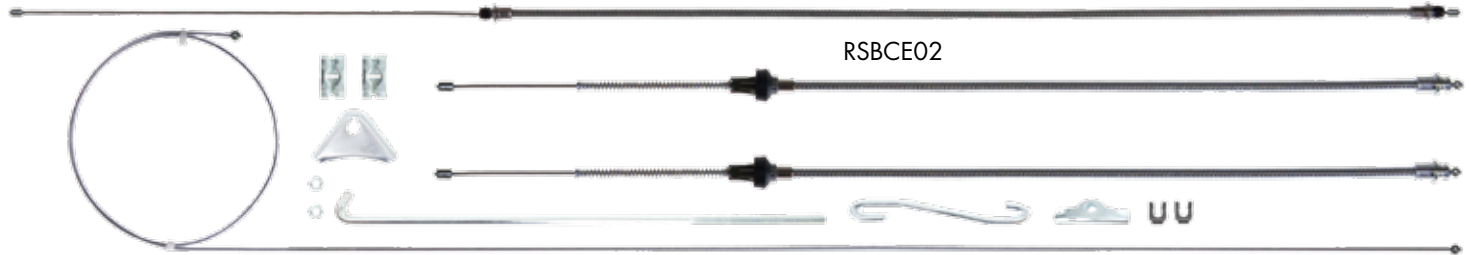

• Front Brake Cables

- EBC7021..... 70E-Body, All - OE Steel
- EBC7021S..... 70E-Body, All - Stainless
- EBC7029.....71-74.....Challenger, All - OE Steel
- EBC7029S.....71-74.....Challenger, All - Stainless
- EBC7035.....71-74.....Cuda, All - OE Steel
- EBC7035S.....71-74.....Cuda, All - Stainless

• Intermediate Brake Cables

- EBC8020..... 71-74E-Body, All - OE Steel
- EBC8020S..... 71-74E-Body, All - Stainless

• E-Brake Hardware

- EBH2009..... 71-74 18-1/2 Hook
- EBH3004..... 71-74Center to Rear Silver Connector
- EBH3001..... 71-74Olive Green Center Pull
- EBH1001..... 70-74Jam Nut
- FHC01 70-74Gold Cadmium Plated C Clip
- EBH3005..... 71-74Equalizer
- EBH2012..... 71-74J Hook
- EBH1007..... 71-74Black Cable Clip
- EBH3003..... 70Silver Center Pull

• E-Brake Cable Kits

- RSBCE03 70Cuda, without Intermediate - OE Steel
- RSBCE03S 70Cuda, without Intermediate - Stainless
- RSBCE04 70Challenger, without Intermediate - OE Steel
- RSBCE04S 70Challenger, without Intermediate - Stainless
- RSBCE01 71-74Cuda, with Intermediate - OE Steel
- RSBCE01S 71-74Cuda, with Intermediate - Stainless
- RSBCE02 71-74Challenger, with Intermediate - OE Steel
- RSBCE02S 71-74Challenger, with Intermediate - Stainless

• Rear Brake Cables

- EBC9022..... 70E-Body, Short - OE Steel
- EBC9022S..... 70E-Body, Short - Stainless
- EBC9023..... 70Cuda, Long - OE Steel
- EBC9023S..... 70Cuda, Long - Stainless
- EBC9024..... 70Challenger, Long - OE Steel
- EBC9024S..... 70Challenger, Long - Stainless
- EBC9033.....71-74.....Challenger - OE Steel
- EBC9033S.....71-74.....Challenger - Stainless
- EBC9038.....71-74.....Cuda, All - OE Steel
- EBC9038S.....71-74.....Cuda, All - Stainless

WHEEL CYLINDERS

Wheel cylinders are priced each.
Hardware is not included.



- WC68.....70-72..... Left Front, 1-3/16"
- WC69.....70-72..... Right Front, 1-3/16"
- WC73.....70-72..... Rear, 10" & 11" Brakes, 15/16"
- WC70.....70-74..... Rear, 9" Brakes, 15/16"



VALVES & BLOCKS

We offer a full line of metering blocks, proportioning valves, distribution blocks & combination valves for factory drum & disc brake applications. Call us for assistance with disc conversion valving.

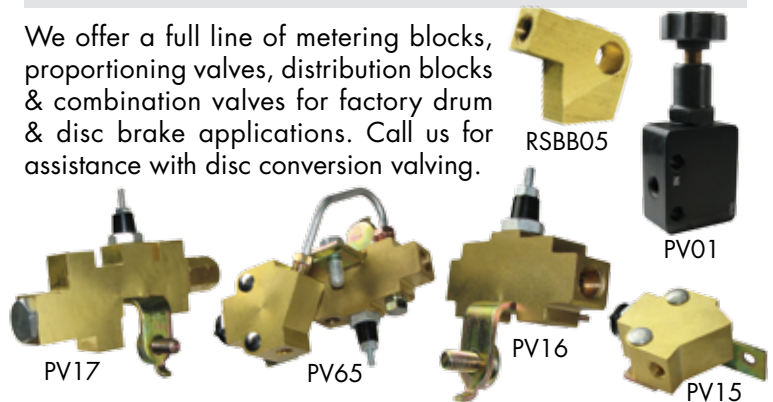

- FHB86.....70-74..... Breather Bolt
- PV01 All Adjustable Proportioning Valve
- PV15.....70-71..... Metering Valve with 3 Ports
- PV16.....70-71..... Disc, Distribution Valve
- PV16.....70-74..... Drum, Distribution Valve
- PV17.....70-71..... Disc Brake Combination Valve
- PV65.....70-71..... Disc Brake Valve 3-Piece Set
- PV66.....70-71..... Disc Brake Valve 2-Piece Set
- RSBB0570-74..... "L" Block on Rear Axle

MOPAR E-BODY BOOSTERS & MASTER CYLINDERS

BOOSTER/MASTER COMBOS

Buy your Booster & Master together at a discounted price. These brake boosters are a direct bolt on for manual brake cars. If you have factory power brakes, you will need to modify your firewall.

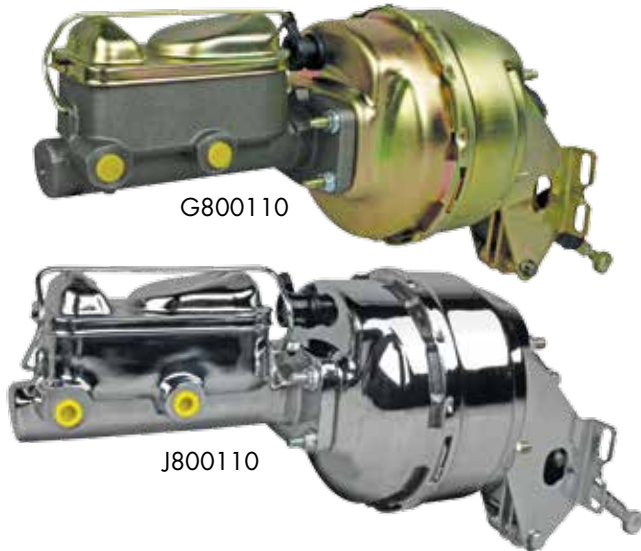

G800110.....8" Dual Booster - 1-1/16" Bore Master, Gold
 J800110.....8" Dual Booster - 1-1/16" Bore Master, Chrome
 G800115.....8" Dual Booster - 15/16" Bore Master, Gold
 J800115.....8" Dual Booster - 15/16" Bore Master, Chrome

BRAKE BOOSTERS

The RPB8001 with high rise bracket is perfect for Hemi cars and vehicles being converted from manual to power brakes. RPB8066 and RPB8070 are great for cars with a factory booster bolted directly to the firewall.



RPB80018" Dual Diaphragm with High Rise Bracket, Gold
 RPB8001C8" Dual Diaphragm with High Rise Bracket, Chrome
 RPB8070Bendix Style with Factory Correct Bracket, Black



MASTER CYLINDERS

All master cylinders are completely new units with no core charge. A deep cylinder pocket with a removable plug provides compatibility with manual brakes as well as power-assisted applications.



DBMC1062-76..... 1-1/16" Bore Diameter
 DBMC10C.....62-76..... 1-1/16" Bore Diameter Chrome
 DBMC1562-76..... 15/16" Bore Diameter
 DBMC15C.....62-76..... 15/16" Bore Diameter Chrome

FUEL PUMP TO CARB LINES

Fuel pump to carburetor lines connect the fuel pump to the carburetor. Brass blocks and fittings are included as noted. These lines are intended to work only with factory pump, motor, intake and carburetor combinations.

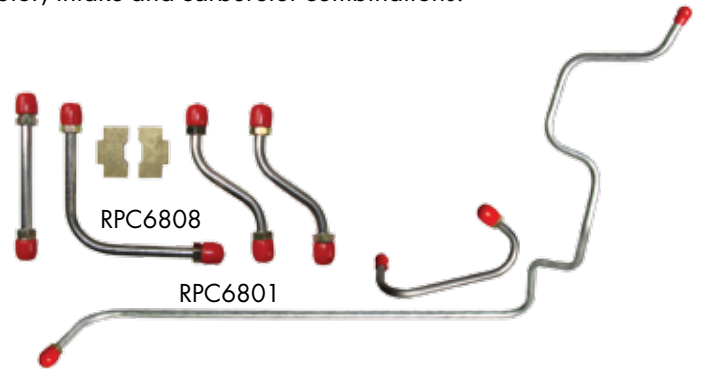

ADD "S" TO PART NUMBER FOR STAINLESS STEEL

RPC6801 ...70-71 ... 340/440 with 6 Pack,
 Upper 4 Lines & 2 Tees 6 Pcs.
 RPC6802 ...70-71 ... 340, 6 Pack, Lower Lines 2 Pcs.
 RPC6803 ...70-71 ... 440, 6 Pack, Lower Lines 2 Pcs.
 RPC6804 ...70-71 ... 426 Hemi, 4 Lines, 2 Carb Fittings,
 Tee & Bracket
 RPC6806 ...70-71 ... 340 with Carter AVS 2 Pcs.
 RPC6807 ...70-71 ... 383 with Carter AVS 2 Pcs.
 RPC6808 ...70-71 ... 400/440 with Carter T-Quad ... 2 Pcs.
 RPC6809 ...70-71 ... 383, 440 with Single Inlet Holley
 RPC7001 ...70-71 ... 440 with Carter AVS 2 Pcs.
 RPC6701 ...70-72... 318 with 2 BBL 2 Pcs.
 RPC6805 71 340 with Carter T-Quad 2 Pcs.
 RPC7202 72 340 with Carter T-Quad
 RPC7302 ...73-74... 340/360 Thermoquad 2 Pcs.

MAIN FUEL LINES

Main lines carry fuel from the tank in the rear of the car to the fuel pump or rail in the front. They are available in 3/8" and 5/16" tubing based on factory specifications. Multiple piece sets are noted. Call for 1/2" lines.

ADD "S" TO PART NUMBER FOR STAINLESS STEEL

EGL700170-745/16" Cuda
 EGL700270-745/16" Challenger
 EGL700370-743/8" Cuda
 EGL700470-743/8" Challenger

VAPOR RETURN LINES

Emission control systems use these 5/16" lines to handle fuel vapors. Some vehicles use a single front to rear line. Others utilize a charcoal canister and require 3 or 4 additional small lines. Multiple piece sets are noted.

ADD "S" TO PART NUMBER FOR STAINLESS STEEL

EGL700770-725/16" Cuda 2 Pcs.
 EGL700870-725/16" Challenger 2 Pcs.
 EGL710770-725/16" Cuda 2 Pcs.
 EGL710870-725/16" Challenger 2 Pcs.
 EGL730773-741/4" Cuda 2 Pcs.
 EGL730873-741/4" Challenger 2 Pcs.

SENDING UNITS

Sending units include floats, gaskets and snap rings where applicable. Our fuel senders are made of stainless steel and operate on the same ohm range as factory gauges.

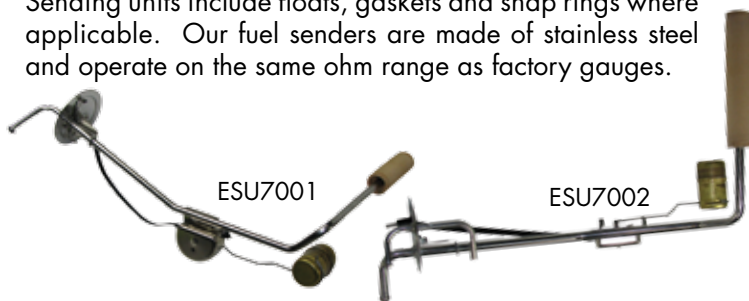

ESU700170-74... 5/16" Main
 ESU700270-74... 3/8" Main



TRANSMISSION COOLER LINES

Transmission cooler lines are sold as pairs. Be sure to verify the type of transmission in your project before ordering. These lines are intended to work only with factory motor, transmission, and radiator combinations.

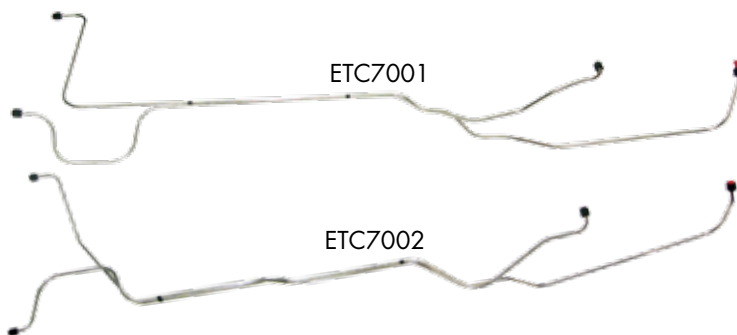

ETC700370-71Hemi, 3 Line Set - OE Steel
 ETC7003S70-71Hemi, 3 Line Set - Stainless
 ETC700170-74727 or 904, Small Block - OE Steel
 ETC7001S70-74727 or 904, Small Block - Stainless
 ETC700270-74727, Big Block - OE Steel
 ETC7002S70-74727, Big Block - Stainless

FUEL TANK VENT LINES

Fuel tank vent lines allow the air inside the fuel tank to escape as it is filled with fuel. They also prevent pressure from building up due to temperature changes.

EFV7002

ADD "S" TO PART NUMBER FOR STAINLESS STEEL

EFV700270 Challenger, Attached to Filler Neck
 EFV7001 .. 70-71 ... Cuda or Challenger, Hardtop without
 Vent Attached to Filler Neck

RETURN FUEL LINES

Return lines carry excess fuel from fuel pump or fuel filter back to the tank. Not all vehicles were equipped with a return line. They are typically made of 1/4" diameter tubing.

EGL700570-72 1/4" Cuda - OE Steel 1 Pc.
 EGL7005S70-72 1/4" Cuda - Stainless 1 Pc.
 EGL700670-72 1/4" Challenger - OE Steel 1 Pc.
 EGL7006S70-72 1/4" Challenger - Stainless 1 Pc.

FUEL LINE CLIPS

Fuel line clips hold tubing to the frame or body of the car. Fasteners are included as noted. See p.290-291 for individual clips.

ECS00570-74 Fuel Line Clips 5/16" & 5/16"
 ECS00670-74 Fuel Line Clips 3/8" & 5/16"
 ECS00770-74 Fuel Line Clips 3/8", 5/16", 1/4"
 ECS00870-74 Fuel Line Clips 3/8" & 1/4"
 ECS00970-74 Fuel Line Clips 3/8"
 ECS01070-74 Fuel Line Clips 5/16"

MOPAR E-BODY SUSPENSION

SUSPENSION COMPONENTS

**COMING
IN 2017**

UPPER & LOWER BALL JOINTS



XK781.....70-74..... Lower, Right hand, with Steering Arm
 XK783.....70-74..... Lower, Left Hand, with Steering Arm
 XK772.....70-74..... Upper

IDLER ARM

RIA6872... 68-74..... All



SWAY BAR LINK KITS

XK525570-74..... All



INNER & OUTER TIE RODS & SLEEVES



XES401L.....70-74Inner
 XES401R70-74Outer
 XES319S70-74Adjusting Sleeve

UPPER & LOWER CONTROL ARM BUSHING KITS

XK408.....70-74..... Upper
 XK791.....70-74..... Lower



SWAY BAR BUSHING

XK524170-74..... All



SUSPENSION KITS

**COMING
IN 2017**

Standard rubber kits meet O.E. specifications. Pre-packaged kits offer huge savings over individual suspension parts. Standard rubber kits meet O.E. specifications. Polyurethane kits provide better handling and a firmer ride. Poly kits include upgraded control arm bushings, sway bar bushings, and sway bar links... Most kits include the following:

- Lower Ball Joints (2)
- Upper Ball Joints (2)
- Lower Ctrl. Arm Bushings (4)
- Upper Ctrl. Arm Bushings (4)
- Strut Rod Bushings (2)
- Tie Rod Adj. Sleeves (2)
- Outer Tie Rods (2)
- Inner Tie Rods (2)



RSK7072 70-74Front Rebuild Kit - Rubber
 RSK7072U.... 70-74Front Rebuild Kit - Poly

AXLE FLANGE DIAGRAMS

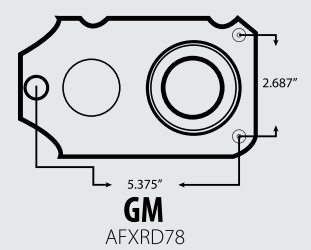
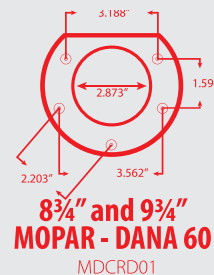
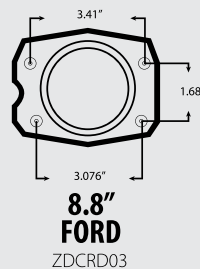
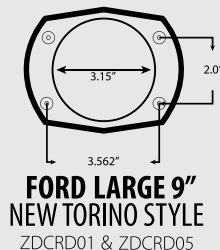
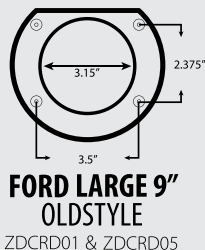
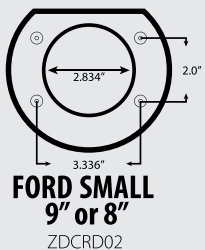
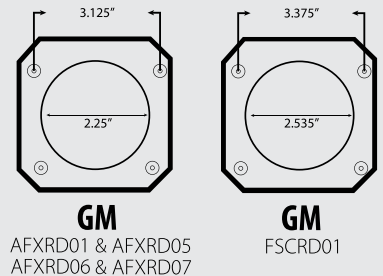
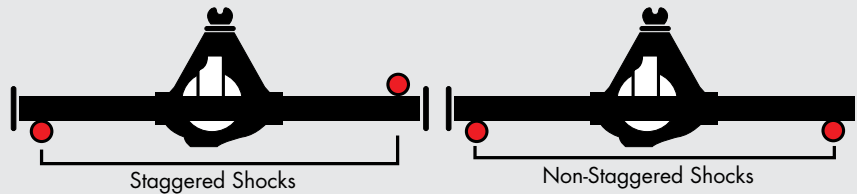

MOPAR E-BODY FRONT DISC CONVERSIONS

**STREET
SERIES**

U.S.A. Made
TIMKEN Bearings

FRONT DISC BRAKE CONVERSION KITS

FITS +15" WHEELS WITH A 5 X 4.5" BOLT PATTERN



AT-THE-WHEEL FRONT KITS From

FRONT CONVERSIONS INCLUDE:

- 11" Rotors (5 x 4.5")
- Forged Spindles
- Timken Bearings
- New Calipers
- Caliper Brackets
- Organic Pads
- Flex Hoses & Hardware
- Valve Bracket & Hardware
- Banjo Bolts & Copper Washers
- Dust Caps
- Castle Nuts & Pins
- Washers
- Grease Seals
- Steering Arm Bolts
- Master Cylinder
- Adjustable Valve
- 8" Dual Booster
- Backing Plates

Right Stuff disc conversions are the most complete kits in the industry at the right price. High quality components, professional packaging, and after-sale support by "hands-on" technicians create an unbeatable value. Consider one of our complete brake line packages for a carefree installation.

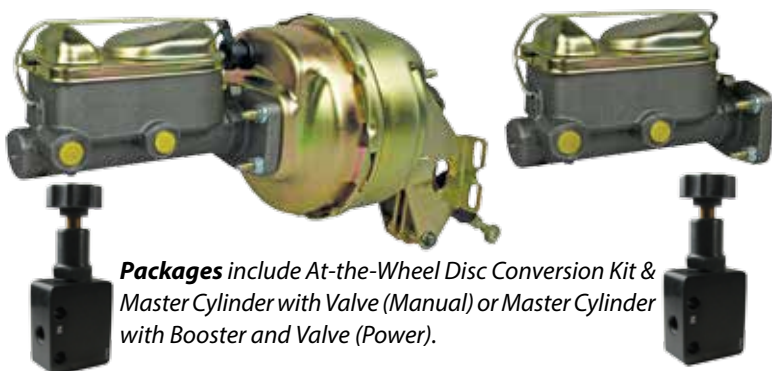

Packages include At-the-Wheel Disc Conversion Kit & Master Cylinder with Valve (Manual) or Master Cylinder with Booster and Valve (Power).

POWER PACKAGE

MANUAL PACKAGE

STOCK HEIGHT FRONT KITS

MDC62WK..... 70-74At-the-Wheel Disc Conversion Kit
MDC62SD 70-74Manual Disc Conversion Package

FRONT DISC BRAKE CONVERSION UPGRADES

SHOW'N GO UPGRADE TRIM KITS

At-the-Wheel Disc Conversion Kits include upgraded drilled slotted rotors with zinc plating, powder coated calipers in red or black, & braided stainless hoses.



STOCK HEIGHT SHOW'N GO

MDC62WKS.....70-74.....At-the-Wheel Disc Conversion Kit - Black
MDC62WKZ.....70-74.....At-the-Wheel Disc Conversion Kit - Red
MDC62SDS70-74..... Manual Disc Conversion Kit - Black
MDC62SDZ70-74..... Manual Disc Conversion Kit - Red
MDC62DCS.....70-74..... Power Disc Conversion Kit - Black
MDC62DCZ.....70-74..... Power Disc Conversion Kit - Red

SHOW STOPPER TRIM PACKAGES

Includes At-the-Wheel Front Disc Conversion Kit with natural finish calipers. The Manual Packages get an upgraded chrome plated master cylinder and combination valve with bracket. Power Packages include an upgraded 8" dual chrome booster.



STOCK HEIGHT SHOW STOPPER

MDC62SDX70-74.....Manual Disc Conversion Package
MDC62DCX.....70-74.....8" Dual Power Disc Conversion Package

BEST OF SHOW TRIM PACKAGES

Includes At-the-Wheel Front Disc Conversion Kit with black or red calipers. The Manual Packages get an upgraded chrome plated master cylinder and combination valve with bracket. Power Packages include an upgraded 8" dual chrome booster.



STOCK HEIGHT BEST OF SHOW

MDC62SDSX 70-74 ... Manual Disc Conversion Package - Black
MDC62SDZX 70-74 ... Manual Disc Conversion Package - Red
MDC62DCSX.... 70-74 ... 8" Dual Power Disc Conv Package - Black
MDC62DCZX.... 70-74 ... 8" Dual Power Disc Conv Package - Red

MOPAR E-BODY 4-WHEEL DISC CONVERSIONS

**STREET
SERIES**

FOUR WHEEL DISC BRAKE CONVERSION KITS

 U.S.A. Made **TIMKEN** Bearings

FRONT CONVERSIONS INCLUDE:

- 11" Rotors (5 X 4.5")
- Forged Spindles
- Timken Bearings
- New Calipers
- Caliper Brackets
- Organic Pads
- Backing Plates
- Flex Hoses & Hardware
- Banjo Bolts & Copper Washers
- Dust Caps
- Castle Nuts & Pins
- Washers
- Grease Seals
- Steering Arm Bolts
- Master Cylinder
- 8" Dual Booster
- Adjustable Valve
- Pedal Rod Extension

REAR CONVERSIONS INCLUDE:

- 11.25" Rotors
- Caliper Brackets & Spacers
- Weld-On Hose Brackets
- New Loaded Caliper
- E-Brake Cables
- Flex Hoses

High quality components, & after the sale support by "hands-on" technicians. Complete brake line packages are available for a care free installation. Verify axle flange measurements for these kits.



Packages include At-the-Wheel Disc Conversion Kit & Master Cylinder with Valve (Manual) or Master Cylinder with Booster and Valve (Power).

POWER PACKAGE

MANUAL PACKAGE

WORKS WITH 15" AND LARGER WHEELS WITH 5 X 4.5" BOLT PATTERN

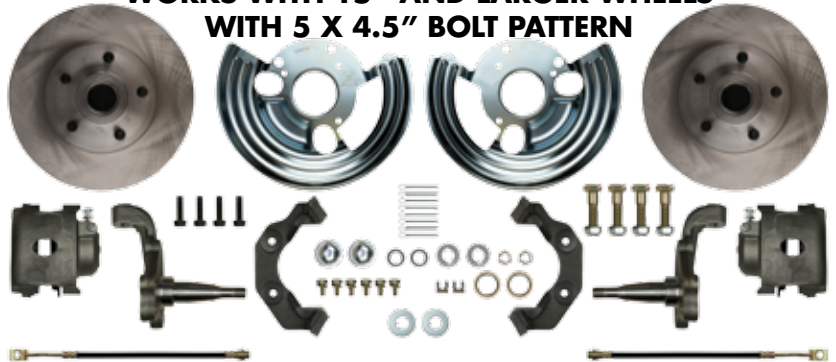

AT-THE-WHEEL FRONT KIT

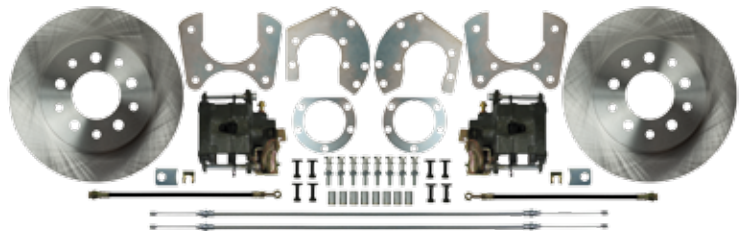

AT-THE-WHEEL REAR KIT

GREEN BEARINGS REQUIRED

STOCK HEIGHT 4-WHEEL KITS

- MDC42SD70-74 Manual Disc Conversion Package
- MDC42DC.....70-74 8" Dual Power Disc Conversion Package
- WBK0470-74 Green Bearing Set (2 Pcs)

4-WHEEL DISC BRAKE CONVERSION UPGRADES

BEST OF SHOW TRIM PACKAGES



Includes At-the-Wheel Front Disc Conversion Kit with black or red calipers. Manual Packages get an upgraded chrome plated master cylinder & combination valve with bracket. Power Packages include an upgraded 8" dual chrome booster.

STOCK HEIGHT BEST OF SHOW

- MDC42SDSX 70-74 Manual Disc Conv Package - Black
- MDC42SDZX 70-74 Manual Disc Conv Package - Red
- MDC42DCSX..... 70-74 8" Dual Power Disc Conv Package - Black
- MDC42DCZX..... 70-74 8" Dual Power Disc Conv Package - Red
- WBK04 70-74 Green Bearing Set (2 Pcs)

SHOW'N GO UPGRADE TRIM KITS

These At-the-Wheel Disc Conversion Kits (stock height or 2" drop) include upgraded drilled slotted rotors with zinc plating, powder coated calipers in red or black, and braided stainless hoses.

278

SHOW STOPPER TRIM PACKAGES



Includes At-the-Wheel Front Disc Conversion Kit with natural finish calipers. The Manual Packages get an upgraded chrome plated master cylinder and combination valve with bracket. Power Packages include an upgraded 8" dual chrome booster.

STOCK HEIGHT SHOW STOPPER

- MDC42SDX 70-74 Manual Disc Conversion Package
- MDC42DCX..... 70-74 8" Dual Power Disc Conversion Package
- WBK04 70-74 Green Bearing Set (2 Pcs)

STOCK HEIGHT SHOW'N GO

- MDC42SDS ... 70-74 ... Manual Disc Conversion Pkg - Black
- MDC42SDZ ... 70-74 ... Manual Disc Conversion Pkg - Red
- MDC42DCS... 70-74 ... Power Disc Conversion Pkg - Black
- MDC42DCZ... 70-74 ... Power Disc Conversion Pkg - Red

MOPAR E-BODY REAR DISC CONVERSIONS

**STREET
SERIES**

REAR DISC BRAKE CONVERSION KITS

REAR CONVERSIONS INCLUDE:

- 11.25" Rotors (5 x 4.5")
- New Loaded Calipers
- Caliper Brackets & Spacers
- Weld-On Hose Brackets
- Flex Hoses
- Hardware
- E-Brake Cables

NOTE:

FITS FACTORY
REAR ENDS
CALL FOR CUSTOM
APPLICATIONS

Right Stuff disc conversions are the most complete kits in the industry at the right price. High quality components, professional packaging, and after-sale support by "hands-on" technicians create an unbeatable value. Consider one of our complete brake line packages for a carefree installation. *See page 274 to verify axle flange measurements for these kits.*

**WORKS WITH 15" AND LARGER WHEELS
WITH 5 X 4.5" BOLT PATTERN**

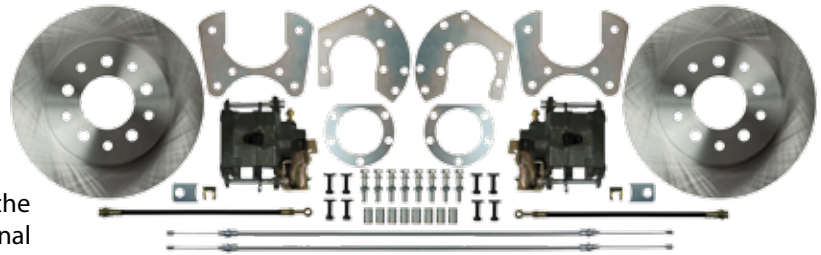

6-5/16" INSIDE ROTOR DIAMETER - 2.85" CENTER HOLE

GREEN BEARINGS REQUIRED

Green bearings allow our caliper brackets to bolt securely to the axle flange. We offer the bearings in a set as part# WBK04. Not recommended for extreme road course applications.

ATTENTION Before you order, be sure to measure the axle flange on your vehicle.

KITS WITH NON-E-BRAKE CALIPERS

- MDCRD1 ...62-72... Rear Disc Conversion (Uses OE Cables)
- WBK0460-76... Green Bearing Set (2 Pcs)

KITS WITH E-BRAKE CALIPERS

- MDCRDM160-76..... 8-3/4", 9-3/4", Dana 60
- WBK0460-76..... Green Bearing Set (2 Pcs)

KITS WITH E-BRAKE - REAR CABLE

- MDCRE01.... 71-74 Rear Disc Cuda with Intermediate
- MDCRE02.... 71-74 Rear Disc Challenger with Intermediate
- MDCRE03..... 70..... Rear Disc Cuda without Intermediate
- MDCRE04..... 70..... Rear Disc Challenger without Intermediate
- WBK04 70-74 Green Bearing Set (2 Pcs)

REAR DISC BRAKE CONVERSION UPGRADES

**STREET
SERIES**

SHOW'N GO UPGRADE TRIM PACKAGES

These At-the-Wheel Rear Disc Conversion Kits include upgraded drilled slotted rotors with zinc plating, powder coated calipers in red or black, and braided stainless hoses.



KITS WITH NON-E-BRAKE CALIPERS

- MDCRD1S ...62-72... Rear Disc Conv - Black (Uses OE Cables)
- MDCRD1Z ...62-72... Rear Disc Conversion - Red (Uses OE Cables)
- WBK0460-76... Green Bearing Set (2 Pcs)

KITS WITH E-BRAKE CALIPERS

- MDCRDM1S60-76 ... 8-3/4", 9-3/4", Dana 60 - Black
- MDCRDM1Z60-76 ... 8-3/4", 9-3/4", Dana 60 - Red
- WBK0460-76 ... Green Bearing Set (2 Pcs)

KITS WITH E-BRAKE - REAR CABLE

- MDCRE01S...71-74 ... Rear Disc Cuda with Intermediate - Black
- MDCRE01Z ..71-74 ... Rear Disc Cuda with Intermediate - Red
- MDCRE02S...71-74 ... Rear Disc Challenger w/Intermediate - Blk
- MDCRE02Z ..71-74 ... Rear Disc Challenger w/Intermediate - Red
- MDCRE03S..... 70..... Rear Disc Cuda without Intermediate - Blk
- MDCRE03Z 70..... Rear Disc Cuda without Intermediate - Red
- MDCRE04S..... 70..... Rear Disc Challenger w/o Intermediate - Blk
- MDCRE04Z 70..... Rear Disc Challenger w/o Intermediate - Red
- WBK0470-74 ... Green Bearing Set (2 Pcs)

MOPAR E-BODY BRAKE LINES



No Brainer BRAKE LINE KITS

DESIGNED FOR DISC CONVERSIONS

When you add disc brakes to your Mopar you normally have to incorporate an adjustable valve into the system and in the case of cars dating prior to 1967 you have an extra port on the master cylinder to contend with. Even if your lines are brand new or great originals, you are going to have a couple of issues trying to use them. Our Mopar 'No Brainer Brake Line Kit' fixes all these issues from your master cylinder all the way back to your rear wheel cylinders or rear calipers. We give you all the lines to complete the installation & also include the rear flex hose and a full clip set to install your lines. Extremely discounted prices and great instructions make this kit a No Brainer.

SIMPLIFY YOUR DISC BRAKE CONVERSION INSTALLATION WITH ALL OF THE BRAKE LINES YOU WILL NEED.

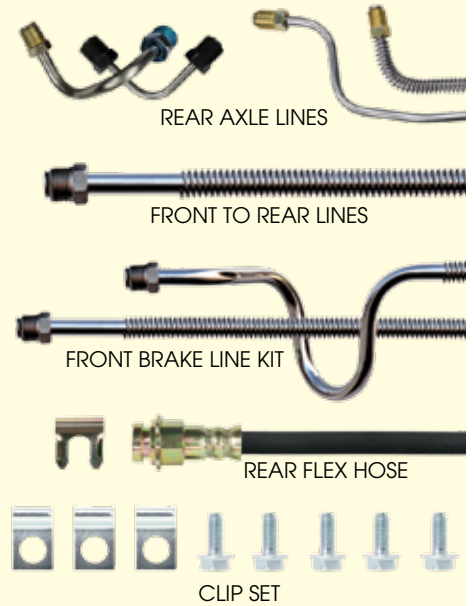

MANUAL - NO VACUUM BOOSTER FRONT DISC/REAR DRUM LINES

EM70U2D70-72 ... Challenger, Under Pass Frame - OE Steel
 EM70U2DS...70-72 ... Challenger, Under Pass Frame - Stainless
 EM70O2D70-72 ... Challenger, Over Pass Frame - OE Steel
 EM70O2DS ..70-72 ... Challenger, Over Pass Frame - Stainless
 EM70U2P70-72 ... Cuda, Under Passenger Frame - OE Steel
 EM70U2PS ...70-72 ... Cuda, Under Passenger Frame - Stainless
 EM70O2P70-72 ... Cuda, Over Passenger Frame - OE Steel
 EM70O2PS...70-72 ... Cuda, Over Passenger Frame - Stainless

MANUAL - NO VACUUM BOOSTER 4-WHEEL DISC MANUAL LINES

EM70U4D70-72.... Challenger, Under Pass Frame - OE Steel
 EM70U4DS....70-72.... Challenger, Under Pass Frame - Stainless
 EM70O4D70-72.... Challenger, Over Pass Frame - OE Steel
 EM70O4DS ...70-72.... Challenger, Over Pass Frame - Stainless
 EM70U4P70-72.... Cuda, Under Passenger Frame - OE Steel
 EM70U4PS70-72.... Cuda, Under Passenger Frame - Stainless
 EM70O4P70-72.... Cuda, Over Passenger Frame - OE Steel
 EM70O4PS....70-72.... Cuda, Over Passenger Frame - Stainless

POWER - WITH VACUUM BOOSTER FRONT DISC/REAR DRUM LINES

EP70U2D.....70-72 ... Challenger, Under Pass Frame - OE Steel
 EP70U2DS70-72 ... Challenger, Under Pass Frame - Stainless
 EP70O2D70-72 ... Challenger, Over Pass Frame - OE Steel
 EP70O2DS ...70-72 ... Challenger, Over Pass Frame - Stainless
 EP70U2P70-72 ... Cuda, Under Passenger Frame - OE Steel
 EP70U2PS.....70-72 ... Cuda, Under Passenger Frame - Stainless
 EP70O2P.....70-72 ... Cuda, Over Passenger Frame - OE Steel
 EP70O2PS....70-72 ... Cuda, Over Passenger Frame - Stainless

POWER - WITH VACUUM BOOSTER 4-WHEEL DISC POWER LINES

EP70U4D..... 70-72 Challenger, Under Pass Frame - OE Steel
 EP70U4DS 70-72 Challenger, Under Pass Frame - Stainless
 EP70O4D 70-72 Challenger, Over Pass Frame - OE Steel
 EP70O4DS ... 70-72 Challenger, Over Pass Frame - Stainless
 EP70U4P 70-72 Cuda, Under Passenger Frame - OE Steel
 EP70U4PS..... 70-72 Cuda, Under Passenger Frame - Stainless
 EP70O4P..... 70-72 Cuda, Over Passenger Frame - OE Steel
 EP70O4PS.... 70-72 Cuda, Over Passenger Frame - Stainless

LINES NOT LISTED?

If you need a line that is not listed in our catalog and you have a good original, you may qualify for free lines. Call us today for details.



MISCELLANEOUS MOPARS

• Dodge Desoto

YTC550155-56... Transmission Cooler Lines - OE Steel
 YTC5501S...55-56... Transmission Cooler Lines - Stainless
 YTC550155-56... DeSoto FireFlight & Adventure Transmission
 Cooler Lines, 2 pcs. - OE Steel
 YTC5501S...55-56... DeSoto FireFlight & Adventure Transmission
 Cooler Lines, 2 pcs. - Stainless

• Diplomat

YGL8501 85 3/8" Main Line - OE Steel 2 Pcs.
 YGL8501S... 85 3/8" Main Line - Stainless 2 Pcs.
 YGL8502 85 3/16" Return Line - OE Steel 2 Pcs.
 YGL8502S... 85 3/16" Return Line - Stainless 2 Pcs.
 YGL8503 85 5/16" Vapor Line - OE Steel 2 Pcs.
 YGL8503S... 85 5/16" Vapor Line - Stainless 2 Pcs.

• Daytona Shelby 2

EGL8401 84 5/16" Main Fuel Line - OE Steel
 EGL8401S ... 84 5/16" Main Fuel Line - Stainless
 EIN8403 84 Front to Rear Brake Line - OE Steel 2 Pcs.
 EIN8403S... 84 Front to Rear Brake Line - Stainless 2 Pcs.
 EMC8401 84 Master Cylinder Lines - OE Steel 2 Pcs.
 EMC8401S... 84 Master Cylinder Lines - Stainless 2 Pcs.
 ERA8401 84 Rear Axle Brake Lines - OE Steel
 ERA8401S ... 84 Rear Axle Brake Lines - Stainless
 EGL8801 88 5/16" Main Fuel Line - OE Steel 2 Pcs.
 EGL8801S ... 88 5/16" Main Fuel Line - Stainless 2 Pcs.
 EGL8802 88 1/4" Return Fuel Line - OE Steel
 EGL8802S ... 88 1/4" Return Fuel Line - Stainless
 EGL8803 88 3/16" Vapor Fuel Line - OE Steel
 EGL8803S ... 88 3/16" Vapor Fuel Line - Stainless
 EIN8801 88 Front to Rear Brake Line - OE Steel 2 Pcs.
 EIN8801S... 88 Front to Rear Brake Line - Stainless 2 Pcs.
 EKT8801 88 Front Brake Line Kit - OE Steel 4 Pcs.
 EKT8801S ... 88 Front Brake Line Kit - Stainless 4 Pcs.
 ERA8801 ... 88-89 ... Rear Axle Brake Lines - OE Steel 2 Pcs.
 ERA8801S .. 88-89 ... Rear Axle Brake Lines - Stainless 2 Pcs.
 EIN8901 89 Front to Rear Brake Line - OE Steel 2 Pcs.
 EIN8901S... 89 Front to Rear Brake Line - Stainless 2 Pcs.



DODGE FUEL TANK VENT LINES

Fuel tank vent lines allow the air inside the fuel tank to escape as it is filled with fuel. They also prevent pressure from building up due to temperature changes.

TFV9901 99 4WD, 3/16" Fuel Vent Line - OE Steel 2 Pcs.
 TFV9901S... 99 4WD, 3/16" Fuel Vent Line - Stainless 2 Pcs.

DODGE FUEL PUMP TO CARBURETOR LINES

Fuel pump to carburetor lines connect the fuel pump to the carburetor. Brass blocks and fittings are included as noted. These lines are intended to work only with factory pump, motor, intake and carburetor combinations.

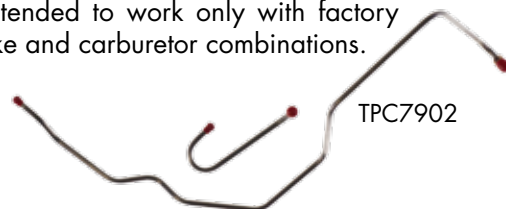

TPC5001 50 Straight 6 - OE Steel
 TPC5001S ... 50 Straight 6 - Stainless
 TPC6603 63 413 4 BBL - OE Steel 2 Pcs.
 TPC6603S ... 63 413 4 BBL - Stainless 2 Pcs.
 TPC6601 66 Slant 6, 225 - OE Steel
 TPC6601S ... 66 Slant 6, 225 - Stainless
 TPC7801 78 360 - OE Steel
 TPC7801S ... 78 360 - Stainless
 TPC7806 78 Voyager, 5/16" - OE Steel
 TPC7806S ... 78 Voyager, 5/16" - Stainless
 TPC7902 79 Thermo Quad Carb. - OE Steel 2 Pcs.
 TPC7902S ... 79 Thermo Quad Carb. - Stainless 2 Pcs.

DODGE TRANS COOLER LINES

Transmission cooler lines are sold as pairs. Be sure to verify the type of transmission in your project before ordering. These lines are intended to work only with factory motor, transmission, and radiator combinations.

TTC6401 ... 64-70 ... 273 Ci, 727 Transmission - OE Steel ... 4 Pcs.
 TTC6401S .. 64-70 ... 273 Ci, 727 Transmission - Stainless ... 4 Pcs.
 KTC7509 75 Dodge Van, 318 Ci - OE Steel
 KTC7509S... 75 Dodge Van, 318 Ci - Stainless
 TTC7801 78-79 ... 8 Cylinder, 2 Line Set - OE Steel
 TTC7801S .. 78-79 ... 8 Cylinder, 2 Line Set - Stainless

DODGE TRANS VACUUM LINES

Transmission vacuum lines connect automatic transmissions to intake vacuum.

TTV7801 78 360 - OE Steel
 TTV7801S... 78 360 - Stainless

DODGE FRONT BRAKE LINE KITS

Front brake line kits consist of all brake lines under the hood, including the master cylinder to the distribution, combination or metering valve & left and right front lines that run to the front flex hoses. Call for individual component pricing. Kits are for vehicles with factory brake systems. If you have a disc conversion or aftermarket valve, call our technical staff for the correct lines.

ADD "S" TO PART NUMBER FOR STAINLESS STEEL

TKT4201..... 42..... Standard Drum.....	3 Pcs.
TKT6601..... 66..... Standard Drum.....	4 Pcs.
TKT7006..... 70..... Power Disc, 2 WD.....	4 Pcs.
KKT7401..... 74..... 1/2 Ton, 2 WD Disc/Drum.....	4 Pcs.
TKT7501..... 75..... Power Drum.....	5 Pcs.
KKT7509..... 75..... Front Brake Line Kit.....	4 Pcs.
TKT7801... 78-79... Li'l Red Express.....	4 Pcs.
TKT7801... 78-79... Li'l Red Express, without Armor.....	4 Pcs.
TKT7802... 78-79... Warlock.....	4 Pcs.
TKT7901..... 79..... Li'l Red Express, with Armor.....	4 Pcs.
TKT7904... 79-87... 3/4 Ton, 4WD, Power Disc.....	5 Pcs.
TKT9205..... 92..... D350 Dually, Reg. Cab Turbo.....	7 Pcs.
TKT9501..... 95..... Ram Ext. Cab Diesel.....	5 Pcs.
TKT9901..... 99..... Ram 4WD ABS.....	8 Pcs.
TKT9902..... 99..... 3/4 Ton, 4WD, Standard Cab, 8' Bed, 5.9 Cummins Diesel, Rear ABS.....	6 Pcs.
TKT2002..... 01..... RAM1500, Ext. Cab, 6' Bed.....	6 Pcs.

DODGE TRUCK MAIN FUEL LINES

Main lines carry fuel from the tank in the rear of the car to the fuel pump or rail in the front. They are available in 3/8" and 5/16" tubing based on factory specifications. Multiple piece sets are noted. Call for 1/2" lines.

ADD "S" TO PART NUMBER FOR STAINLESS STEEL

TGL5001..... 50..... Front to Rear	
TGL6600... 61-66... 5/16" Main	
TGL6601..... 66..... Cab to Pump	
TGL7501..... 75..... 3/8" Main Line.....	2 Pcs.
KGL7509..... 75..... Dodge Van, Main, 318 ci.....	2 Pcs.
TGL7712..... 77..... 5/16" Warlock.....	2 Pcs.
TGL7801..... 78..... 5/16" Li'l Red Express	
TGL7901..... 79..... 5/16" Li'l Red Express.....	2 Pcs.
TGL7902..... 79..... Li'l Red Express.....	2 Pcs.
TGL7903..... 79..... 5/16" Warlock.....	2 Pcs.
TGL7907..... 79..... 5/16" Main.....	2 Pcs.
TGL7908..... 79..... 1/4" Return	
TGL8403..... 84..... 3/8" K-20, Diesel Dual Tank.....	3 Pcs.

JEEP RETURN FUEL LINES

Return lines carry excess fuel from fuel pump or fuel filter back to the tank. Not all vehicles were equipped with a return line. They are typically made of 1/4" diameter tubing.

ADD "S" TO PART NUMBER FOR STAINLESS STEEL

OGL8002..... 76-81..... CJ-7, 1/4" Return
OGL7702..... 77..... Scout, 1/4" Return
OGL7802..... 78..... CJ-5, 1/4" Return
OGL7902..... 79..... CJ-7 Quadratrax Return
OGL8004..... 82-86..... Scrambler Return
OGL8302..... 82-86..... CJ-7, 1/4" Return

DODGE FRONT TO REAR BRAKE LINES

Front to rear brake lines go from the distribution, combination or metering valve along the length of the vehicle to the rear flex hose. Manufactured in 1 or 2 pieces based on factory specs.

ADD "S" TO PART NUMBER FOR STAINLESS STEEL

TIN5001.....50.....Standard
TIN6600.....66.....Long Bed
TIN6601.....66.....Short Bed
TIN7006.....70.....8' Bed with Front Disc, 2 WD
KIN7401.....74.....1/2 Ton, 2 WD Short Bed Disc/Drum
TIN7501.....75.....1/2 Ton
KIN7509.....75.....Dodge Van
TIN7801... 78-79... Li'l Red Express
TIN7802... 78-79... Warlock
TIN7904... 79-87... 3/4 Ton, 4 WD, Short Bed
TIN7905.....79.....4 WD, Ram
TIN8508.....85.....2 or 4 WD, 4 Door Longbed
TIN9205.....92.....D350 Dually, Reg. Cab, 8' Bed
TIN9501.....95.....Ext. Cab, Longbed, Diesel
TIN9602.....96.....Short Bed
TIN2002.....01.....RAM 1500 Extended Cab, 6' Bed
TIN2007.....00.....Dakota, Extra Cab, Short Bed, 2 WD, Rear ABS

DODGE REAR AXLE BRAKE LINES

Rear axle brake lines include a pair of lines that run across the rear axle housing. These lines connect the wheel cylinders or calipers to the flex hose in the middle of the rear end. These lines work with original housings that use factory brakes. Modifications such as rear disc brakes or narrowed rear ends will likely require special lines. Call for more information.

ADD "S" TO PART NUMBER FOR STAINLESS STEEL

TRA6601..... 66..... All
TRA7001..... 70..... Standard Duty, 2 WD
KRA7401..... 74..... 1/2 Ton, 2 WD
TRA7501..... 75..... 1/2 Ton
KRA7509..... 75..... Dodge Van, Rear Axle
TRA7601..... 76..... Dodge 1/2 Ton, 4x4
TRA7801... 78-79... Li'l Red Express
TRA7802... 78-79... Warlock
TRA7906... 79-87... 3/4 Ton, Dana 60, Dually
TRA8202..... 82..... Dodge 3/4 Ton Dana 60, Std Axle
YRA8202..... 82..... Rampage
TRA9001... 90-93... Ram 250 Cummings Diesel, Dana 70
TRA9902..... 99..... 3/4 Ton, 4WD, Dana 80, Rear ABS

JEEP TRANS COOLER LINES

Transmission cooler lines are sold as pairs. Intended to work only with factory motor, transmission, and radiator combinations. If your system is not 100% stock, call us to discuss options.

OTC7901.....74-80..... Scout, 4 Wheel Drive - OE Steel
OTC7901S.....74-80..... Scout, 4 Wheel Drive - Stainless

JEEP REAR AXLE BRAKE LINES

Rear axle brake lines include a pair of lines that run across the rear axle housing. These lines connect the wheel cylinders or calipers to the flex hose in the middle of the rear end. These lines work with original housings that use factory brakes. Modifications such as rear disc brakes or narrowed rear ends will likely require special lines. Call for more information.

ADD "S" TO PART NUMBER FOR STAINLESS STEEL

ORA6901.....69.....Commando, V6, WD, Drum.....	2 Pcs.
ORA7201.....72.....CJ-5.....	2 Pcs.
ORA7901... 74-80...Scout, 4 Wheel Drive.....	2 Pcs.
ORA8001... 76-81...CJ-7.....	2 Pcs.
ORA7601... 76-82...CJ-5.....	2 Pcs.
ORA7901.....79.....Scout.....	2 Pcs.
ORA7902.....79.....CJ-7 Quadratrac.....	2 Pcs.
ORA8003... 82-86...CJ-7.....	2 Pcs.
ORA8801.....88.....Wrangler.....	2 Pcs.
ORA9501.....95.....Wrangler.....	2 Pcs.
ORA9601.....96.....CJ.....	2 Pcs.
ORA9701... 97-06...All Jeeps.....	2 Pcs.

JEEP BRAKE BOOSTER AND MASTER CYLINDER COMBOS

Includes a Booster with firewall brackets, Master Cylinder, proportioning valve, valve bracket with hardware, and a pair of master cylinder lines. Changes to your factory lines may be required!



OPB748674-86... CJ Booster Assembly, 8" Dual

JEEP FRONT BRAKE LINE KITS

Front brake line kits consist of all brake lines under the hood. This includes the master cylinder to the distribution, combination or metering valve. The left and right front lines that run to the front flex hoses are also included. Call for individual component pricing. These line kits are for vehicles with factory brake systems.

ADD "S" TO PART NUMBER FOR STAINLESS STEEL

OKT6901.....69.....Commando, V6, 4WD, Drum.....	5 Pcs.
OKT7201.....72.....CJ-5, Power Drum.....	4 Pcs.
OKT7904... 74-80...Scout, Power Disc, 4WD.....	4 Pcs.
OKT8001... 76-81...CJ-7, 4WD & Scrambler.....	4 Pcs.
OKT7601... 76-82...CJ-5, Power Disc.....	4 Pcs.
OKT7901.....79.....CJ-7 Quadratrac.....	4 Pcs.
OKT7904.....79.....Scout.....	4 Pcs.
OKT8301... 82-86...CJ-7, 4WD & Scrambler.....	4 Pcs.
OKT9501.....95.....Wrangler.....	4 Pcs.
OKT9701... 97-06...Jeep with ABS.....	4 Pcs.

JEEP FRONT TO REAR BRAKE LINES

Front to rear brake lines go from the distribution, combination or metering valve along the length of the vehicle to the rear flex hose. Lines are made in 1 or 2 pieces based on factory specifications.



OIN8301
CLOSE UP VIEW

ADD "S" TO PART NUMBER FOR STAINLESS STEEL

OIN6901.....69.....Commando, V6, 4WD, Drum.....	
OIN7201.....72.....CJ-5.....	
OIN7901... 74-80...Scout, 4 Wheel Drive.....	
OIN8001... 76-81...CJ-7, 4 Wheel Drive.....	
OIN9701... 97-06...All Jeeps.....	
OIN7601... 76-82...CJ-5.....	
OIN7602.....78.....CJ-5.....	
OIN7901.....79.....Scout.....	
OIN7902.....79.....CJ-7 Quadratrac.....	
OIN8003... 82-86...Scrambler.....	
OIN8301... 82-86...CJ-7, 4 Wheel Drive.....	
OIN9501.....95.....Wrangler.....	
OIN9601.....96.....CJ.....	

JEEP VAPOR LINES

Emission control systems use these 5/16" lines to handle fuel vapors. Some vehicles use a single front to rear line. Others utilize a charcoal canister and require 3 or 4 additional small lines. Multiple piece sets are noted.

ADD "S" TO PART NUMBER FOR STAINLESS STEEL

OEM8001... 76-81...CJ-7, 5/16" Vapor.....	
OEM7701.....77.....5/16" Vapor.....	
OEM7901.....79.....CJ-7 Quadratrac Vapor.....	
OEM8301... 82-86...CJ-7, 5/16" Vapor.....	
OGL7803.....78.....CJ-5, 5/16" Vapor.....	
OGL8005... 82-86...Scrambler Vapor.....	

JEEP MAIN FUEL LINES

ADD "S" TO PART NUMBER FOR STAINLESS STEEL

OGL8001... 76-81...CJ-7, 5/16" Main.....	
OGL7701.....77.....Scout, 5/16" Main.....	
OGL7705.....77.....J-20 5/16" Fuel Line.....	
OGL7706.....77.....J-20 3/8" Fuel Line.....	
OGL7801... 78.....CJ-5, 5/16" Main.....	
OGL7901... 79.....CJ-7 Quadratrac Main.....	2 Pcs.
OGL8003... 82-86...Scrambler Main.....	
OGL8301... 82-86...CJ-7, 5/16" Main.....	



INDIVIDUAL COMPONENTS

POWER BRAKE BOOSTERS

Universal Boosters have no mounting brackets. Each booster has 4 studs on the back that make a 3.375" square center to center.



- PB7001 7" Single Slimline Booster
- PB7001S 7" Single Slimline Booster, Stainless
- PB7537 7" Dual Slimline Booster
- PB7537C 7" Dual Slimline Booster, Chrome
- PB7537S 7" Dual Slimline Booster, Stainless
- PB8531 8" Dual Slimline Booster
- PB8531C 8" Dual Slimline Booster, Chrome
- PB8531S 8" Dual Slimline Booster, Stainless
- PB9002 9" Single Slimline Booster
- PB9002S 9" Single Slimline Booster, Stainless

BRAKE BOOSTER BRACKETS



- BBK001 A/F/X Body Midsize GM Brackets (pr)
- BBK001S A/F/X Body Midsize GM Brackets (pr) Stainless
- BBK002 55-58 Full Size GM Brackets (pr)
- BBK002S 55-58 Full Size GM Brackets (pr) Stainless
- BBK004 59-64 Full Size GM Brackets (pr)
- BBK004 63-72 Chevy / GMC Truck Brackets (pr)
- BBK004S 63-72 Chevy / GMC Truck Brackets (pr) Stainless
- BBK006 High-Rise Bracket

MASTER CYLINDERS



- DBMC01 Single Bail, Dual Reservoir, Disc/Drum (Short)
- DBMC05 Dual Bail, Dual Reservoir, Disc/Disc
- DBMC05C Dual Bail, Dual Reservoir, Disc/Disc, Chrome
- DBMC09 Dual Bail, Dual Reservoir, Disc/Drum
- DBMC11 Power Disc, with Bleeders, 1-1/8" Bore, Shallow Exact Repo for '69, Delco Licensed
- DBMC16 Power Disc, with Bleeders, 1-1/8" Bore, Shallow Same as DBMC11 without Casting Marks
- DBMC51C 1-1/8" Bore, Slimline Flat Top, Chrome
- DBMC56C 1" Bore, Slimline Flat Top, Chrome
- DBMC18 4 Ports, GM Port Size
- DBMC07 Drum/Drum
- DBMC10 Mopar Disc/Drum
- DBMC19 Single Bail, Dual Reservoir with Bleeders
- DBMC15 Mopar 15/16" Bore Master Cylinder



INDIVIDUAL COMPONENTS

PROPORTIONING VALVES



- PV01 Adjustable Prop. Valve
- PV68 Round GM Disc Brake Valve
- PV70 Round GM Disc Brake Valve
- PV71 Disc/Drum GM Brass Prop. Valve
- PV71C Disc/Drum GM Chrome Prop. Valve
- PV72 Disc/Disc GM Brass Prop. Valve
- PV72C Disc/Disc GM Chrome Prop. Valve
- RV02 2# Residual Valve
- RV10 10# Residual Valve

PROP VALVE BRACKETS



- PVB71 GM Valve Bracket
- PVB71S GM Valve Bracket, Stainless
- PVB72 GM Valve Bracket, Bottom Mount

STAINLESS STEEL LINE CLIPS



- RSCLP01S 3/16" Single Clip (Priced per Foot)
- RSCLP02S 1/4" Single Clip (Priced per Foot)
- RSCLP03S 5/16" Single Clip (Priced per Foot)
- RSCLP04S 3/8" Single Clip (Priced per Foot)
- RSCLP31S 1/2" Single Clip (Priced per Foot)

ELECTRIC VACUUM PUMP



- EVP01 Electric Vacuum Pump

TUBING



- TUB316 3/16" (Priced per Foot)
- TUB14 1/4" (Priced per Foot)
- TUB516 5/16" (Priced per Foot)
- TUB38 3/8" (Priced per Foot)
- TUB12S 1/2" (Priced per Foot)

GRAVEL GUARD SPRING



- GG316S 3/16" Stainless (Priced per Foot)
- GG314S 1/4" Stainless (Priced per Foot)
- GG316S 5/16" Stainless (Priced per Foot)
- GG338S 3/8" Stainless (Priced per Foot)

PROTECTIVE LOOM

- LOM3BLK 3/16" ID, Black Asphalt (Priced per Foot)
- LOM4BLK 1/4" ID, Black Asphalt (Priced per Foot)
- LOM5BLK 5/16" ID, Black Asphalt (Priced per Foot)
- LOM6BLK 3/8" ID, Black Asphalt (Priced per Foot)

CLIPS & FASTENERS



CALL FOR BULK PRICING

Part #	Diameter	Description
RSCLP01	3/16"	R Clip - Silver Zinc
RSCLP01S	3/16"	Single Clip Stainless Steel
RSCLP02	1/4"	R Clip - Silver Zinc
RSCLP02S	1/4"	Single Clip Stainless Steel
RSCLP03	5/16"	R Clip - Silver Zinc
RSCLP03S	5/16"	Single Clip Stainless Steel
RSCLP04	3/8"	R Clip - Silver Zinc
RSCLP04S	3/8"	Single Clip Stainless Steel
RSCLP05	5/16"	R Clip with Tab - Blue
RSCLP06	3/8"	R Clip - Black
RSCLP07	3/16"	R Clip with Tab - Gold Cadmium
RSCLP08	3/8" x 1/4"	R Clip with Slot - Silver Zinc
RSCLP09	1/4" x 3/16"	R Clip with Tab - Silver Zinc
RSCLP10	1/4" x 3/16"	Double Push-In Clip - Silver Zinc
RSCLP11	5/16" x 5/16"	Spring Clip - Black
RSCLP12	5/16" x 1/4"	Spring Clip - Silver Steel
RSCLP13	3/8" x 5/16"	R Clip with Tab - Black
RSCLP14	5/8"	R Clip - Silver Zinc
RSCLP15	3/8"	R Clip - Blue
RSCLP16	3/8" x 1/4"	R Clip with Tab - Gold Cadmium
RSCLP17	1/4" x 3/16"	Double Sided Push-In Clip - Red
RSCLP18	5/16"	Push-In Spring Clip - Black
RSCLP19	3/16"	Vacuum Retainer Clip - Black
RSCLP20	3/16"	Push-In Spring Clip - Black
RSCLP21	1/4"	Push-In Spring Clip - Black
RSCLP22	3/8"	Push-In Spring Clip - Black
RSCLP23	N/A	Parking Brake Clip - Black
RSCLP24	3/8"	R Clip with Tab - Silver Zinc
RSCLP25	5/16" x 5/16"	R Clip - Silver Zinc
RSCLP26	3/8" x 3/8"	R Clip - Silver Zinc
RSCLP27	5/16" x 5/16"	R Clip - Silver Zinc Vinyl Coated
RSCLP28	3/8" x 3/8"	R Clip - Silver Zinc Vinyl Coated
RSCLP29	3/16" x 3/16"	R Clip - Silver Zinc
RSCLP30	3/8"	R Clip with Tab - Blue
RSCLP31	1/2"	R Clip - Silver Zinc
RSCLP31S	1/2"	Single Clip Stainless Steel

CLIPS & FASTENERS



CALL FOR BULK PRICING

Part #	Diameter	Description
RSCLP32.....	3/8" x 1/4"	R Clip F-Body Style - Silver Zinc
RSCLP33.....	3/8" x 1/4"	R Clip with Slot - Olive
RSCLP34.....	1/2"	R Clip with Slot - Black
RSCLP35.....	3/8" x 3/8"	R Clip with Slot - Black
RSCLP36.....	3/16"x3/16"	Spring Clip - Black
RSCLP37.....	1/4"	GM J Style Push-In Clip - Black
RSCLP38.....	3/16"	GM J Style Push-In Clip - Silver Zinc
RSCLP39.....	3/8"	GM J Style Push-In Clip - Black
RSCLP40.....	3/8" x 1/4"	Spring Clip - Black
RSCLP41.....	1/4"	Squeeze Rivet Clip - Silver Zinc
RSCLP42.....	5/16"	Half Round Line Clamp - Black
RSCLP43.....	3/8"	Half Round Line Clamp - Black
RSCLP44.....	3/8" x 3/8"	Double Half Round Clamp - Black
RSCLP45.....	3/16"	Frame Retainer Clip - G. Cadmium

Part #	Diameter	Description
RSCLP46.....	3/8"	Frame Retainer Clip - Silver Zinc
RSCLP47.....	5/16"x5/16"	Double Sided Push-In Clip - Gold
RSCLP48.....	3/8"x1/4"	Double Sided Push-In Clip - Gold
RSCLP49.....	5/16"x5/16"	Double Sided Push-In Clip - Gold
RSCLP50.....	1/2"	Frame Line Clip - Black
RSCLP51.....	7/16"	R Clip - Silver Zinc
RSCLP52.....	5/16"	Mopar "J" Line Clip
RSCLP53.....	1/2"x3/8"	R Clip with Tab - Silver Zinc
RSCLP54.....	1/4"	R Clip with Tab - Gold Cadmium
RSCLP55.....	3/16"x1/4"	R Clip with Tab - Silver Zinc
RSCLP56.....	1/4"x5/16"	R Clip with Tab - Silver Zinc
RSCLP57.....	1/2"	R Clip with Tab - Silver Zinc
RSCLP58.....	5/16"	Chevy Rear Axle Clip
RSCLP60.....	3/8"	67-76 Buick Skylark - GS Clip

E-BRAKE HARDWARE

WHILE SUPPLIES LAST



Part #	Description
EBH1001	Jam Nut
EBH1002	Spring
EBH1003	Silver Washer
EBH1004	Self Tapper, Screw
EBH1007	Black Cable Clip
EBH2001	6" Silver Front Hook
EBH2002	Side Hook
EBH2003	12" Silver Hook
EBH2004	J Hook
EBH2005	Silver Rear Hook
EBH2006	Front Hook
EBH2007	Side Hook
EBH2008	8-5/8" Hook

Part #	Description
EBH2009	18-1/2" Hook
EBH2011	10-1/4" J Hook
EBH2012	J Hook
EBH2013	7 3/8" Hook
EBH2015	4-1/2" Hook
EBH3001	Olive Green Center Pull
EBH3002	Center to Rear Connector
EBH3004	Center to Rear Connector
EBH3005	Equalizer
EBH3006	Center Pull
RSCLP23	Parking Brake Clip
FHC01	Gold Cadmium Plated C Clip

CUSTOM BRAKE, FUEL & TRANSMISSION LINES

Looking for the perfect set of brake lines for your rod? There is no magic bullet, but there is hope. If you want spring wrap or cloth loom to make the job look professional, no problem.

Here is the deal, we are an industry leader in brake and fuel line reproduction. You simply need to tell us what to do. Make patterns or take measurements and we'll make you a beautiful set of custom stainless lines for your rod.



CALL FOR BULK PRICING

Part	Tube	Thread	Hex	Description
ST3	3/16	3/8-24	3/8	Std. Tube Nut, Gold
ST3S	3/16	3/8-24	3/8	Std. Tube Nut, Stainless
ST3L	3/16	3/8-24	3/8	Std. Long Thread
ST3P	3/16	3/8-24	3/8	Std. Tube Plug
ST4	1/4	7/16-24	7/16	Std. Tube Nut, Gold
ST4S	1/4	7/16-24	7/16	Std. Tube Nut, Stainless
ST4P	1/4	7/16-24	7/16	Std. Tube Plug
ST4U	1/4	7/16-24	7/16	Std. 1/4" Union
ST5	5/16	1/2-20	1/2	Std. Tube Nut, Gold
ST5S	5/16	1/2-20	1/2	Std. Tube Nut, Stainless
ST6	3/8	5/8-18	5/8	Std. Tube Nut, Gold
ST6S	3/8	5/8-18	5/8	Std. Tube Nut, Stainless
SP1	3/16	3/8-24	7/16	Purple
SP2	3/16	7/16-24	7/16	Red
MSP18	3/16	10X1	12.7mm	Silver
SP21	1/4	7/16-24	7/16	Gold, Long Thread
SP22	5/16	1/2-20	1/2	Fitting for Mustang
MSP1	3/16	10x1	7/16	Purple, Long Thread
MSP2	1/4	14x1.5	15mm	Black
MSP3	1/4	12x1	1/2	Anodized
MSP4	3/8	16x1.5	5/8	Anodized
MSP5	5/16	14x1.5	5/8	Anodized
MSP6	3/16	10x1	1/2	Gold
MSP7	1/4	12x1	7/16	Olive
MSP8	3/16	12x1	1/2	Red
MSP17	3/16	12X1	16mm	Silver
SP2S	3/16	7/16-24	7/16	Stainless

Part	Tube	Thread	Hex	Description
SP3	1/4	1/2-20	9/16	Orange
SP3S	1/4	1/2-20	9/16	Stainless
SP4	3/16	1/2-20	1/2	Black
SP4S	3/16	1/2-20	1/2	Stainless
SP5	3/16	1/2-20	9/16	Green
SP5S	3/16	1/2-20	9/16	Stainless
SP6	1/4	9/16-18	9/16	Blue
SP6S	1/4	9/16-18	9/16	Stainless
SP7	3/16	9/16-18	5/8	Olive, Ford MC Lines
SP7S	3/16	9/16-18	5/8	Stainless
MSP11	3/16	10x1.5	14mm	Olive
MSP9	3/16	11x1.5	12mm	Orange
SP8	3/16	9/16-20	9/16	Blue, Chrysler MC Lines
SP9	3/16	1/2-20	9/16	Black, Chrysler MC Lines
SP10	3/16	1/2-20	9/16	Violet, Chrysler MC Lines
SP11	3/16	3/8-24	3/8	Gold, Long Hex, Chrysler
SP12	3/16	3/8-24	7/16	Red, Long Thread
SP13	5/16	5/8-18	5/8	Red, GM Trans. Lines
SP14	3/16	3/8-24	7/16	Long Hex, GM Drum Wh. Ls.
SP15	5/16	1/2-20	1/2	Long Hex, GM Trans. Lines
SP17	1/4	7/16-24	7/16	Chrysler Master Cylinder
SP19	1/4	7/16-24	9/16	Gold, Large Hex
SP20	3/16	3/8-24	9/16	Gold, Large Hex
MSP16	3/16	11X1.5	11mm	Silver
FE5B	5/16	1/2-20	5/8	Black, Female, Chry. Trans.
FE5G	5/16	1/2-20	5/8	Gold, Female, Ford Trans.