

Right Weigh 510 Series Interior Dash-Mounted Load Scale



Installation Instructions:

When installing a Right Weigh interior load scale there are two basic installation options.

Option #1: Replace Existing Air Suspension Pressure Gauge. Use this option if you have an air suspension pressure gauge in your dash and want to replace it with the Right Weigh load scale.

Note: If the vehicle has a twist-in or pop-in gauge console, it may restrict the ability to install a Right Weigh load scale in the same location as the air suspension pressure gauge. If so, select option #2.

Option #2: New Gauge and Air Line Installation. Use this option if you do not have an air suspension pressure gauge, or cannot mount the Right Weigh interior load scale in the same location as your air suspension gauge.

Option #1: Replace Existing Air Suspension Pressure Gauge

Step 1: Dump the air from the suspension system. Turn the vehicle off.

Step 2: Locate and remove the AIR SUSPENSION pressure gauge from the dash panel. If needed, refer to the vehicle owner's manual, or a qualified technician, for detailed instructions on dash panel assembly and gauge replacement.

Step 3: Mount the Right Weigh load scale into the dash panel using the U-bracket provided with the gauge. (Fig.1)

Step 4: Attach the existing air line from the air suspension pressure gauge into the back of the Right Weigh load scale. (Fig. 2)

⚠ Attention: Fittings and thread sizes may vary depending on the make and model of the vehicle. It may be necessary to purchase additional fittings in order to connect the existing airline to the back of the Right Weigh load scale.

Step 5: Locate a switched electrical power and ground source for the gauge LED lights. **Do not connect the Right Weigh load scale to the dash light dimmer circuit.** Attach the positive (RED) wire to the power source and the negative (BLACK) wire to ground. (Fig. 3)

Step 6: Confirm the electrical power to the Right Weigh load scale is working properly. Air-up the vehicle suspension and check all air line connections for leaks.

Step 7: Reassemble the dash panel.

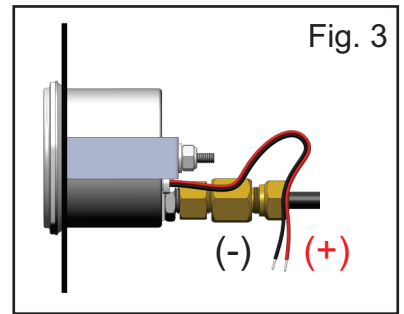
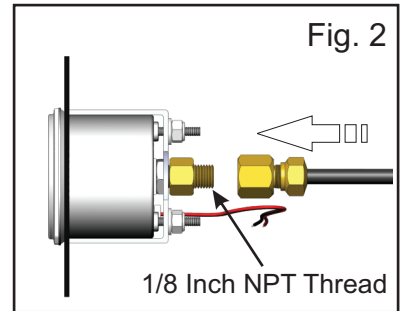
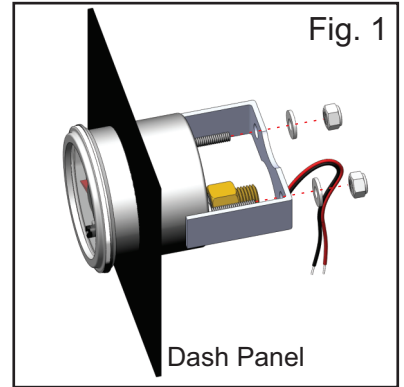

Option #2: New Gauge and Air Line Installation

You will need approximately 30 feet of standard 1/4" air line and the following fittings to install a new load scale:

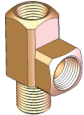

Street Tee:
Thread size to match air bag fittings.
(1/4" NPT or 3/8" NPT)



Male Straight Air Line Fitting:
For 1/4" air line, and thread size to match the street tee.

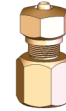

Female Air Line Fitting:
Straight or elbow fitting for 1/4" air line and 1/8" NPT thread size.

Step 1: Dump the air from the suspension system. Turn the vehicle off.

Step 2: Locate an available factory gauge hole in the dash panel, or create a new hole. The hole size must be 2 1/16 inches (52.5mm) in diameter.

⚠ Attention: To avoid damage to internal dash components, DO NOT drill or punch a hole in the dash panel without making sure there is ample space behind the dash panel for a new gauge. If needed, refer to the vehicle owner's manual, or a qualified technician, for detailed instructions on dash panel assembly and gauge installation and/or replacement.

Step 3: Mount the Right Weigh load scale into the dash panel using the U-bracket provided. (Fig. 1)

Step 4: Remove the suspension air line and fitting from the most accessible air bag on the drive axle. (Fig. 4)

Step 5: Insert a street tee fitting into the top of the air bag, then reattach the suspension air line and fitting into the top of the street tee fitting. (Fig. 5)

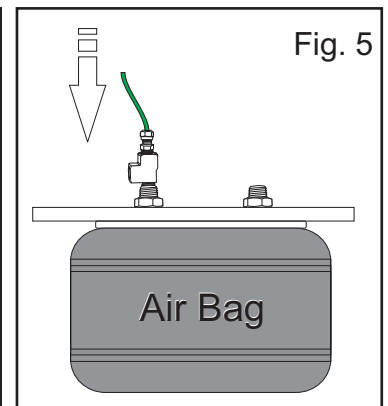
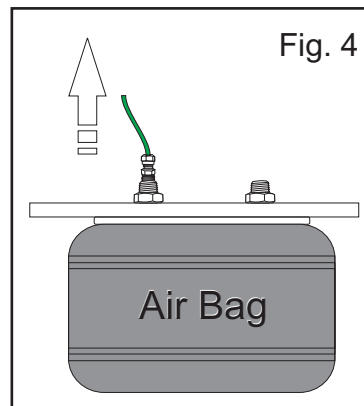

(cont.):

Step 6: Using the appropriate sized fittings and air line, run a new air line from the street tee to the load scale mounted in the dash. (Fig. 6)

Step 7: Locate a switched electrical power and ground source for the gauge LED lights. **Do not connect the Right Weigh load scale to the dash light dimmer circuit.** Attach the positive (RED) wire to the power source and the negative (BLACK) wire to ground. (Fig. 3)

Step 8: Confirm the electrical power to the gauge is working properly. Air-up the vehicle suspension and check all air line connections for leaks.

Step 9: Reassemble the dash panel.

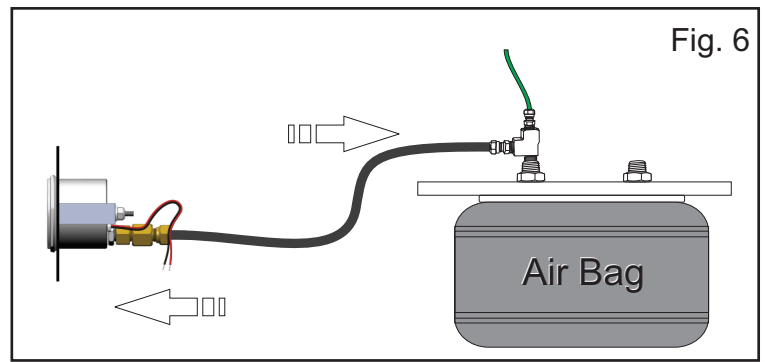

Fig. 6

Calibration Instructions:

Step 1: The vehicle must be loaded. For best results, calibrate with a loaded weight that is within 1,500 LBS (680 KG) of the legal limit for the axle group. **(Do Not Calibrate Empty!)**

Step 2: Using a certified in-ground scale, obtain a loaded weight for the axle group attached to the Right Weigh load scale.

Step 3: Park on a level surface. Shift the transmission to neutral and set the parking brakes.

Step 4: Chock the wheels to prevent unexpected vehicle movement.

Step 5: Release the parking brakes.

Step 6: Make sure the Height Control Valve (HCV) has fully inflated the air bags. If needed, briefly dump the air from the suspension and allow the HCV to refill the system. (This may take several minutes depending on the type of HCV.)

Step 7: Using a small flat head screwdriver, turn the calibration screw on the dial face until the gauge matches the certified scale weight. (Fig. 7)



Fig. 7

Operating Instructions:

Step 1: Park on a level surface. Shift the transmission to neutral and set the parking brakes.

Step 2: Chock the wheels to prevent unexpected vehicle movement.

Step 3: Release the parking brakes.

Step 4: Make sure the Height Control Valve (HCV) has fully inflated the air bags. If needed, briefly dump the air from the suspension and allow the HCV to refill the system. (This may take several minutes depending on the type of HCV.)

Step 5: View the load scale to determine on-the-ground axle group weight.

Select LED Light Color: There are seven (7) LED colors to choose from. Press the small button on the lower left side of the dial face to select a color. (Fig. 8)



Fig. 8

Troubleshooting:

Erratic or inaccurate readings could result from the following:

- 1) The vehicle is not parked on a level surface: Parking on sloped or banked surfaces will cause the vehicle weight distribution to shift between the axle groups.
- 2) The vehicle's brakes are on: When the brakes are set, they could apply additional pressure on the suspension air bags.
- 3) The vehicle is parked on an uneven or rough surface: If one or more of the vehicle's wheels are in a pothole, this could result in additional pressure on the suspension air bags.
- 4) The height control valve (HCV) is malfunctioning: To test for an HCV problem, follow steps 1 to 5 of the operating instructions (the trailer should be loaded). Write down the weight reading from the load scale. Then, drive the vehicle around the block and return to the same location. Follow steps 1 to 5 of the operating instructions again to get a second reading for the load scale. If the two readings are significantly different, then the HCV is probably malfunctioning.