



Time Tested • Time Proven

Universal wiring kit with 7- to 6-wire cord

part number 15267

Installation Instructions

All specifications are subject to change without notice.

ROADMASTER, Inc.

Parts

The towed vehicle wiring kit consists of –

- (1) 27-foot wiring harness
- (4) Hy-Power™ diodes
- (1) 10-12 gauge butt connector
- (1) 3-foot length of split loom
- (1) self-tapping screw
- (1) ring terminal
- (11) wire ties

The Flexo-Coil™ power cord kit consists of –

- (1) 7- to 6-wire power cord with one 6-wire plug and one 7-wire plug
- (1) 6-wire electrical socket
- (2) Nylock nuts
- (1) socket bracket
- (2) ½-inch machine screws



WARNING

Read the instructions before installing the kit components, and wire the towed vehicle according to the instructions and illustrations. Failure to understand how to install this product could result in an electrical malfunction or other collateral or consequential damage.



CAUTION

Do not install this kit in any vehicle with a “low side switching” system. A low side switching system will prevent the taillights from functioning properly when they receive power from the motorhome.

Use either magnetic tow lights or a taillight bulb and socket kit to wire these vehicles for towing.

Step A

Identify the towed vehicle’s lighting system

1. The vehicle will be wired for towing according to the type of brake and turn signals. There are two types – combined or separate (Figure 1). In a **combined** system, the brake light does the flashing for the turn signal; in a **separate** system,

there are amber or red turn signal lights which are separate from the brake lights.

Note: if the motorhome has a separate lighting system, a 3-to-2 converter must be installed in order to use this kit. A 3-to-2 converter converts a separate system to a combined system.

Many late-model motorhomes come with converters already installed – test for this before installation: if the motorhome’s trailer plug energizes the same pins for both brake lights and turn signals, then a 3-to-2 converter is already installed and the motorhome should be treated as combined.

If a converter is needed, install ROADMASTER’s Brite-Lite™, part number 732.

continued on next page

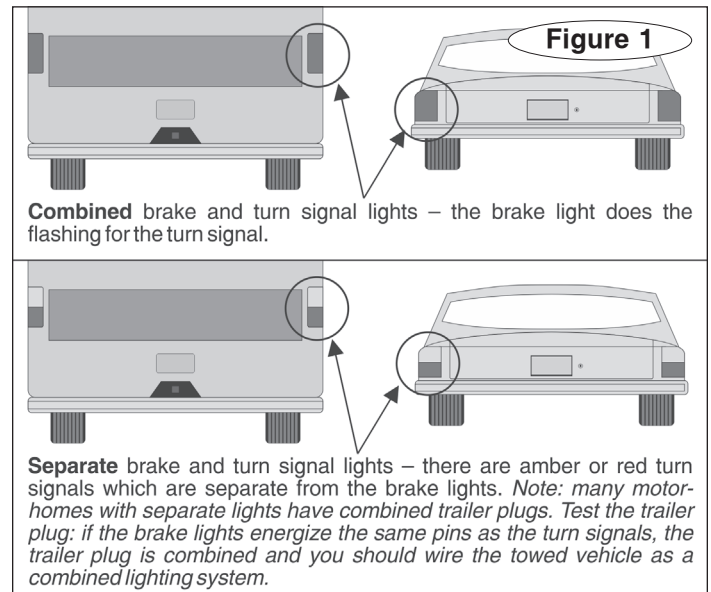

IMPORTANT NOTICE!

Safety Definitions

Statements in these instructions identified as follows are of special significance.



WARNING

WARNING indicates a potentially hazardous situation which, if not avoided, could result in property damage, serious personal injury or even death.



CAUTION

CAUTION indicates a potentially hazardous situation which, if not avoided, may result in property damage, or minor or moderate personal injury.

CAUTION

CAUTION used without the safety alert symbol indicates a potentially hazardous situation which, if not avoided, may result in property damage.

NOTE

Refers to important information and is placed in italic type. It is recommended that you take special notice of these items.

Step B

Wire the vehicle for towing

1. Expose the wires behind both taillight assemblies. (It may be necessary to remove the taillight assemblies from the exterior of the vehicle to gain access.)

2. With a circuit tester, identify the brake light, taillight and turn signal wiring.

3. Attach the diodes according to the appropriate schematic on page three.

4. Jump the diodes attached to the taillights, as shown in the schematic.

Note: use the yellow female spade connector to jump the diodes.

5. Following the schematic, separate the bonded wires in the wiring harness and attach the appropriate wires to the diodes at either one of the taillight assemblies.

Peel off the appropriate wires and route them to the other side.

Attach those wires to the other diodes.

6. Use the included ring terminal and a self-tapping screw to attach the ground wire.

Note: to avoid grounding problems, attach the wire to a good chassis ground, preferably directly to the frame.

CAUTION

Refer to the owner's manual before attaching the ground wire. Some manufacturers stipulate that ground wires must be attached at specific locations.

Significant damage to the vehicle's electrical system, as well as other consequential, non-warranty damage will occur if the ground wire is not attached at one of these points.

WARNING

Attach the diodes as close to the towed vehicle's lights as possible, to avoid interaction with other circuits which may be tied into the center brake light, the running lights, the turn signals or the brake light wires. Attaching the diodes farther away may cause the towed vehicle's lights to work improperly, as well as cause damage to other electrical components in the vehicle.

CAUTION

Failure to attach the diodes as indicated in the wiring schematics will create a backfeed through the vehicle's electrical system, which will allow electrical current from the towed vehicle to disrupt one or both of the vehicles' electrical systems.

Additionally, if a supplemental braking system is installed it may not operate, or may only operate intermittently.

Step C

Route the wiring harness

1. You will route the other end of the wiring harness to the front of the vehicle. Before you begin, plan a route that avoids the possibility of fraying or melting the wiring against

moving parts, sharp edges, the fuel lines or hot components. (If the OEM wiring harness is accessible, consider routing the harness alongside it.)

2. Route the wiring harness. Where appropriate, use a section of the included split loom to protect the wires; use one or more of the included wire ties to secure the wiring in place.

WARNING

Route the wiring harness to avoid moving parts, sharp edges, the fuel lines or hot components such as the engine or exhaust system.

Wiring exposed by moving parts, sharp edges or hot components may cause a short circuit, which can result in damage to the vehicle's electrical system as well as other, consequential damage.

Wiring which is attached in close proximity to the fuel lines may ignite the fuel.

3. If it was necessary to drill a hole, seal it with silicone sealant after you have routed the wires through.

Step D

Attach the wiring harness

1. After you route the wiring harness to the front of the vehicle, choose a mounting point for the socket.

If the towed vehicle has a Roadmaster Series 4 or 5 EZ Twistlock™ tow bar mounting bracket, you will attach the socket to the built-in mounting posts on the main cross brace.

Otherwise, choose a suitable point to attach the socket at the front of the vehicle.

CAUTION

The socket should be mounted near the center. If it's attached too far to either side, it may be pulled away when the motorhome turns.

2. Disassemble the socket and route the wire harness through the socket bracket and socket housing.

Attach the wiring to the inner plug. Refer to the 6-wire diagram on page three.

Note: leave a 12-inch service loop at the socket for future modifications. Secure the service loop with one of the wire ties.

Apply a clear silicone sealant around each wire entry and set screw indentation to help weatherproof the socket and secure the set screws.

Reassemble the socket, using all the components that you removed.

3. Use the included ½" machine screws and Nylock nuts to attach the socket at the point you chose in Step 1.

4. Test each of the circuits on both the 6-wire and 7-wire sockets to confirm that the lighting functions correctly. Refer to the diagrams on page three.

Wiring schematics

CAUTION

The color codes listed below are the most commonly used. However, color coding is not standard with all manufacturers.

Use the color codes for initial reference only; confirm the function of each wire with a circuit tester.

The towed vehicle's lighting system may not function, or function improperly, if the wires are not connected correctly. Cross-wiring may also cause a short circuit, a blown fuse or other non-warranty damage.

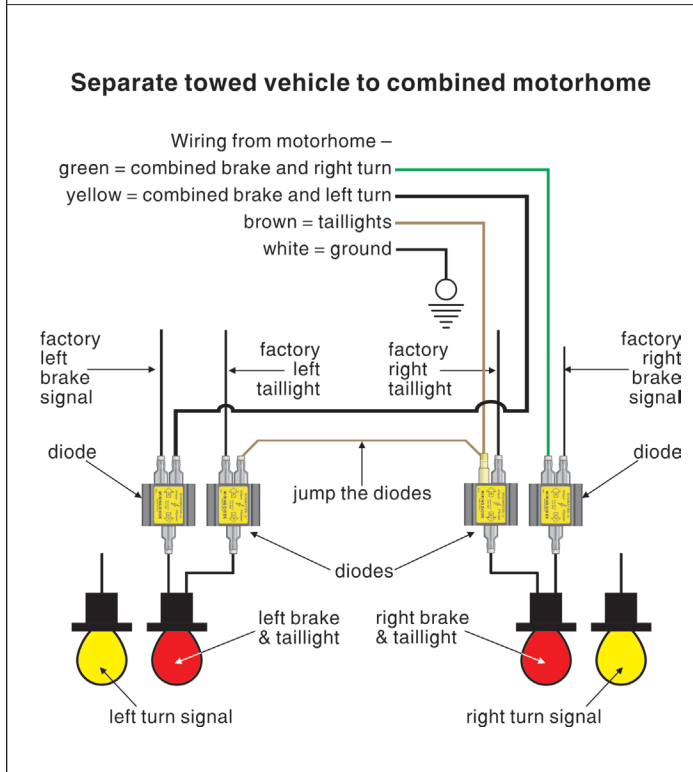
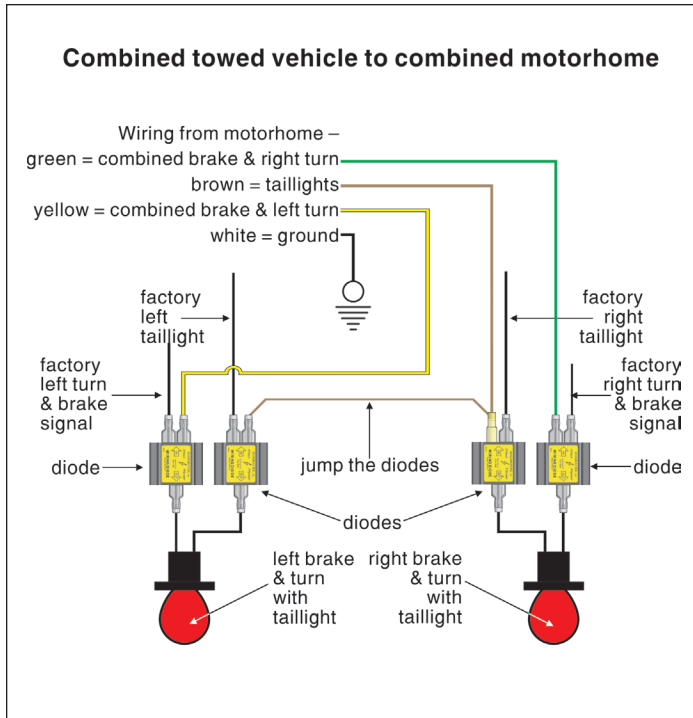

Socket wiring diagrams

Both of the plugs on the power cord have been wired to standard electrical codes. To ensure that their wiring matches the sockets...

- ...use the diagram of the 6-wire socket to wire the towed vehicle's socket; and
- ...before towing, use a circuit tester to confirm that the wiring on the motorhome's 7-way socket matches the diagram of the 7-way socket below.

front of 6-wire socket

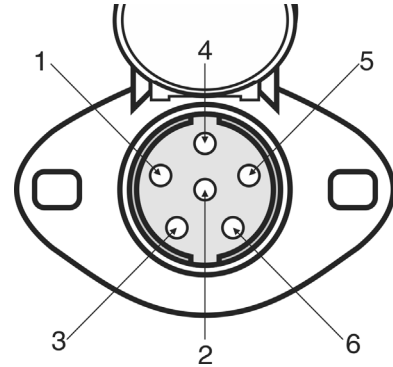

Socket Pin Number	Circuit
1	Brake light (not used)
2	Auxiliary (not used)
3	Right turn
4	Taillight
5	Ground
6	Left turn

front of 7-wire socket

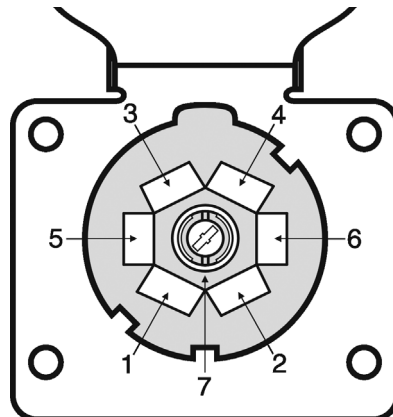

Socket Pin Number	Circuit
1	Ground
2	Brake light (for separate-to-separate systems only)
3	Taillight
4	Charge line (not used)
5	Left turn
6	Right turn
7	Auxiliary (not used)

Don't do the Fuse Limbo...

How about if you never had to spend another minute with your face on the floor mat, gazing up into a black void, hunting for a miniscule piece of plastic playing hide and seek?

You don't have to.

FuseMaster eliminates the necessity of having to remove a fuse for towing, then having to reinsert it for driving. After it's installed you simply flip a switch to accomplish the same task.

There are several FuseMasters which, collectively, fit most vehicles which must have fuses removed for towing.



...Just flip a switch!

No more dead battery!

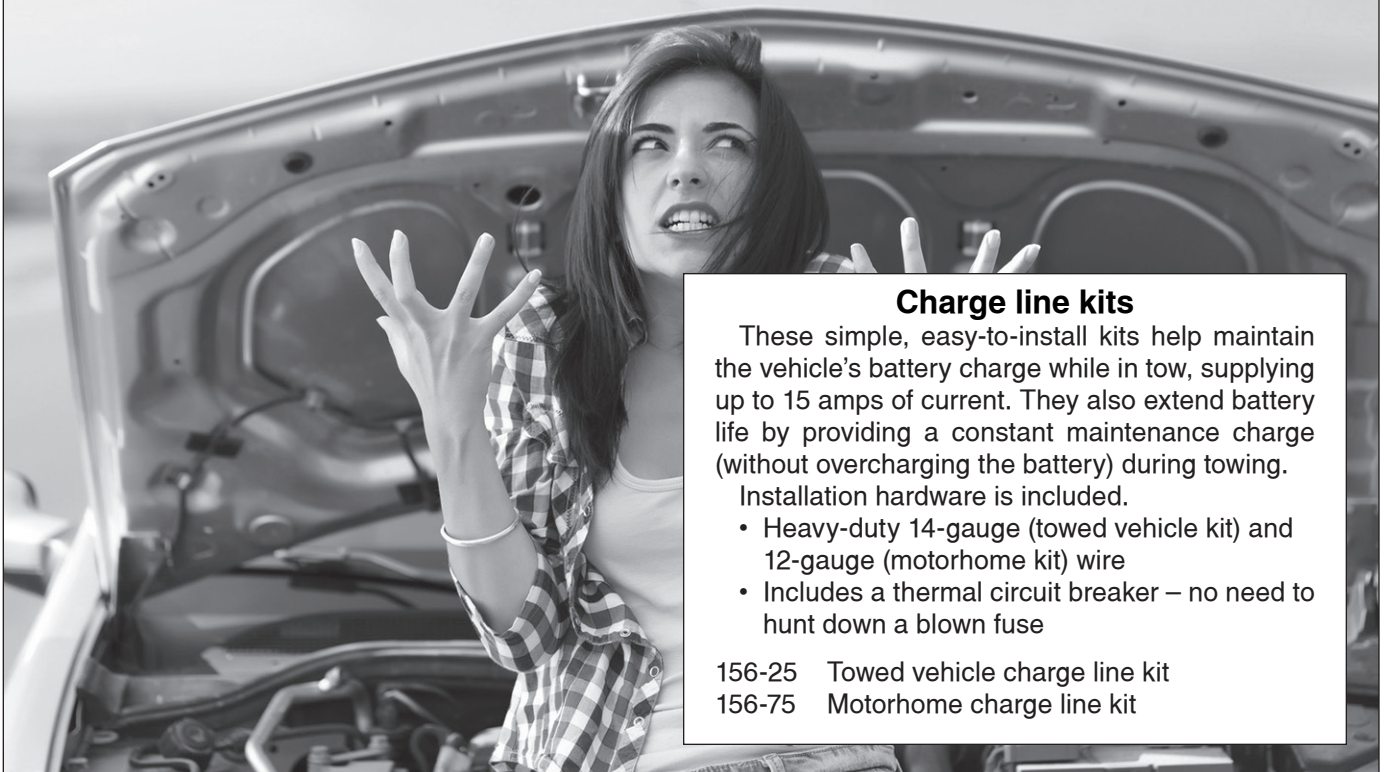

Charge line kits

These simple, easy-to-install kits help maintain the vehicle's battery charge while in tow, supplying up to 15 amps of current. They also extend battery life by providing a constant maintenance charge (without overcharging the battery) during towing.

Installation hardware is included.

- Heavy-duty 14-gauge (towed vehicle kit) and 12-gauge (motorhome kit) wire
- Includes a thermal circuit breaker – no need to hunt down a blown fuse

- 156-25 Towed vehicle charge line kit
- 156-75 Motorhome charge line kit